

Fixed-Height Mobile Stand for **ActivPanel**

INTERACTIVE FLAT PANEL STAND OPTIONS

PRODUCT SPECIFICATIONS

Fixed-Height Mobile Stand Specifications

Compatible with all sizes of ActivPanel 5, ActivPanel i-Series, ActivPanel 6, and ActivPanel Elements series

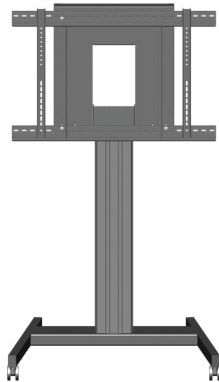

PHYSICAL SPECIFICATIONS

Product Dimensions	1039 x 1800 x 731 mm (41 x 71 x 29 in)
Packed Dimensions	Box 1 of 2: 1100 x 770 x 175 mm (43.3 x 30.3 x 6.9 in) Box 2 of 2: 1215 x 250 x 180 mm (47.8 x 10 x 7.1 in)
Net Weight	34 kg (75 lbs)
Packed Weight	Box 1 of 2: 30.3 (67 lbs) Box 2 of 2: 16.6 (37 lbs)

PACKED CONTENTS

What's in the Box	Box 1 of 2: Mobile base, panel adapter Box 2 of 2: Fixed column, spacer, screw kit, user guide
-------------------	---

ADDITIONAL REQUIREMENTS

Requires the Promethean VESA mount (AP-WALLMNT or AP-WALLMNT-2) that ships as standard with some panels.

OPTIONAL ACCESSORIES

Push/pull handles, laptop tray, camera mount

WARRANTY

Five-Year Warranty (upgrade options available and vary by region). For more information, visit PrometheanWorld.com/ActivCare.

INSTALLATION

The installation of this product should be completed by a qualified installer. Use of components not supplied by Promethean or not meeting minimum specifications may impact performance, safety and warranty. For more information, visit Support.PrometheanWorld.com.

COMPLIANCE & CERTIFICATION

Regulatory Certification UL Recognized 62368-1, CE, CB

SUPPORT

For all Promethean products, visit Support.PrometheanWorld.com.

Fixed-Height Mobile Stand for ActivPanel 2019 v7 SS 05/20 v1.1 EN

© 2020 Promethean Limited. All rights reserved. Promethean Ltd. is owner of a number of trademarks in several jurisdictions across the worldPage 1 including but not limited to Promethean, the Promethean logo, ActivPanel, Nickel, Cobalt, Titanium, Vellum, and ActivSoundBar. All third-party trademarks (including logos and icons) referenced by Promethean remain the property of their respective owners. Unless specifically identified as such, Promethean's use of third-party trademarks does not indicate any relationship, sponsorship, or endorsement between Promethean and the owners of these trademarks. Applicable Terms and Conditions for warranty and support available at PrometheanWorld.com/Warranty. All weights and dimensions are approximate. Product specifications are subject to change without notice. PrometheanWorld.com.

TECHNICAL DRAWINGS

Fixed-Height Mobile Stand

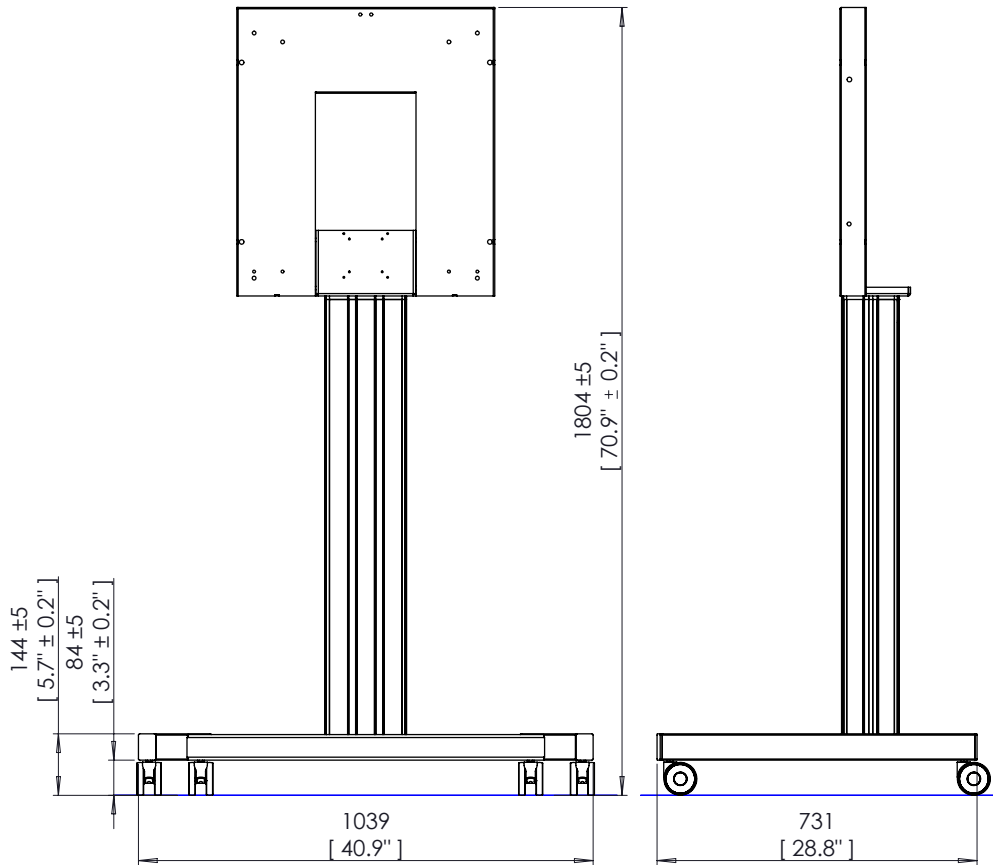

Fixed-Height Mobile Stand for ActivPanel 2019 v7 SS 05/20 v1.1 EN

© 2020 Promethean Limited. All rights reserved. Promethean Ltd. is owner of a number of trademarks in several jurisdictions across the world including but not limited to Promethean, the Promethean logo, ActivPanel, Nickel, Cobalt, Titanium, Vellum, and ActivSoundBar. All third-party trademarks (including logos and icons) referenced by Promethean remain the property of their respective owners. Unless specifically identified as such, Promethean's use of third-party trademarks does not indicate any relationship, sponsorship, or endorsement between Promethean and the owners of these trademarks. Applicable Terms and Conditions for warranty and support available at PrometheanWorld.com/Warranty. All weights and dimensions are approximate. Product specifications are subject to change without notice. PrometheanWorld.com.