



**RMB2040  
Rackmount Kit  
Installation Instructions**

[www.tek.com](http://www.tek.com)



075-1099-00

Copyright © Tektronix. All rights reserved. Licensed software products are owned by Tektronix or its subsidiaries or suppliers, and are protected by national copyright laws and international treaty provisions.

Tektronix products are covered by U.S. and foreign patents, issued and pending. Information in this publication supersedes that in all previously published material. Specifications and price change privileges reserved.

TEKTRONIX and TEK are registered trademarks of Tektronix, Inc.

### **Contacting Tektronix**

Tektronix, Inc.  
14150 SW Karl Braun Drive  
P.O. Box 500  
Beaverton, OR 97077  
USA

For product information, sales, service, and technical support:

- In North America, call 1-800-833-9200.
- Worldwide, visit [www.tek.com](http://www.tek.com) to find contacts in your area.

---

## Service safety summary

Only qualified personnel should perform service procedures. Read this Service Safety Summary and the General Safety Summary in the product service manual or the instruction manual.

**Do Not Service Alone.** Do not perform internal service or adjustments of this product unless another person capable of rendering first aid and resuscitation is present.

To prevent the instrument and rack from falling on the operator, two or more installers should install the instrument into the rack cabinet. After completing the installation procedure, the installers should verify that the instrument and rack cabinet will not tip forward while the instrument is in the extended position.

**Disconnect Power.** To avoid electric shock, switch off the instrument power, then disconnect the power cord from the mains power.

**Use Care When Servicing With Power On.** Dangerous voltages or currents may exist in this product. Disconnect power and disconnect test leads before removing protective panels, soldering, or replacing components.

To avoid electric shock, do not touch exposed connections.

## Kit description

These instructions describe the installation of the rackmount kit to your standard bench-top instrument. The rackmount kit is a collection of parts that, once installed, configure the instrument for mounting in a fixed position into a standard 19-inch equipment rack.

## Products

**TBS2xx4 Series** All Serial Numbers

## Kit parts list

The following table and figure show the parts list of the rackmount kit.

**Table 1: RMB2040 Rackmount Kit**

Item	Quantity	Part number	Description
–	1 each	075-1099-00	TECH MANUAL: INSTRUCTIONS, THIS DOCUMENT
1	2	367-0450-00	HANDLE, BOW; CARRYING
2	1 each	426-2652-00	FACEPLATE, LEFT
3	1 each	407-6072-00	BRACKET, LEFT SIDE
4	1 each	407-6034-00	BRACKET, REAR FEET
5	1 each	407-6066-00	BRACKET, TOP HOLDER
6	1 each	407-6035-00	BRACKET, TOP
7	1 each	407-6033-00	BRACKET, BOTTOM
8	1 each	407-6071-00	BRACKET, RIGHT SIDE
9	1 each	426-2651-00	FACEPLATE, RIGHT
–	14	211-1275-00	SCREW, MACHINE, 6-32 X312 PANHEAD T15, WITH THREAD LOCKING PATCH

Table 1: RMB2040 Rackmount Kit, (cont.)

Item	Quantity	Part number	Description
10	1 each	016-2006-00	KIT, HARDWARE
	4	210-0833-00	WASHER, RECESSED; 0.42 ID X 0.112 THK, STL NI PLATED, 0.588 OD
	4	210-1061-00	WASHER, FLAT; 0.203 ID X 0.625 OD X 0.062, ZINC PLATED STEEL
	4	210-1546-00	SCREW, MACHINE, PANHEAD 8-32 X .500, PHILLIPS
	4	210-1547-00	WASHER, LOCK NO. 8, SPLIT, .040 THICK
	4	210-1548-00	WASHER, FLAT 12 OD X 6.4 ID X 1.6 THK
	14	211-0507-00	SCREW, MACHINE; 6-32 X 0.312, PNH, STEEL, ZINC PLATE, T15 TORX
	4	211-0538-00	SCREW, MACHINE; 6-32 X 0.312, FLH, 100 DEG, ZINC PLATED STEEL, T10 TORX
	4	211-1218-00	SCREW, M6 X 16MM OVAL HEAD, PHILLIPS
	4	211-1219-00	SCREW, M5 X 16MM OVAL HEAD, PHILLIPS
	4	212-0043-00	SCREW, MACHINE; 8-32 X 0.5, FLH, 100 DEG, STL CD PL, POZ
	4	212-0591-00	SCREW, MACHINE; 10-32 X .750 OVAL HEAD, POZI
	4	213-0199-00	SCREW, MACHINE; 12-24 X 0.75, OVH, STL NP, POZ
11	1 pair	351-1095-00	SLIDE ASSY; PAIR, W/STD HARDWARE KIT AND REAR BRACKET

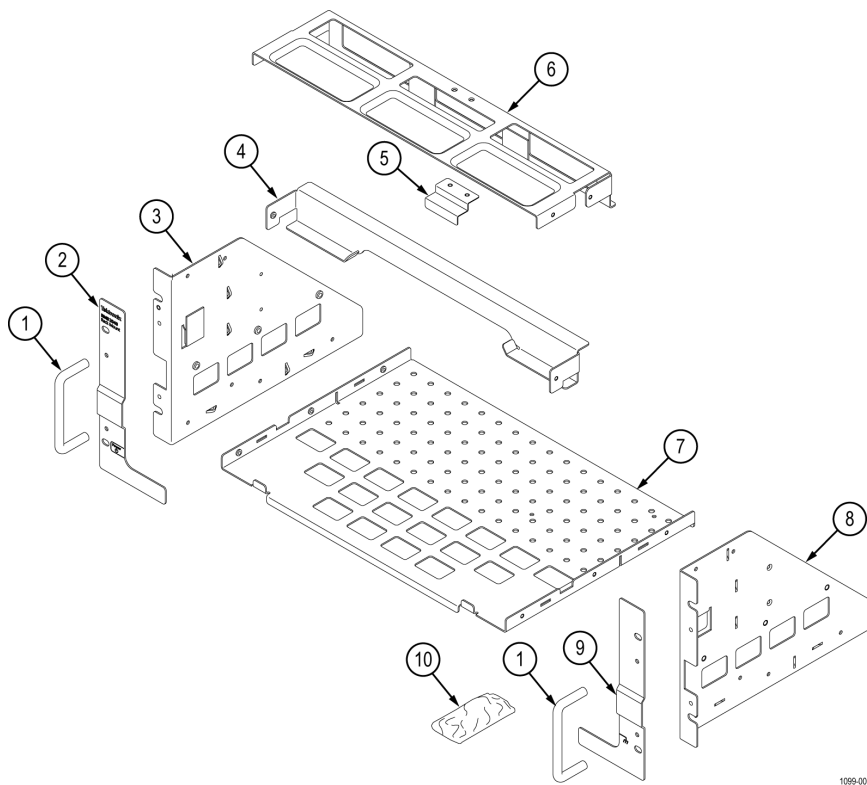
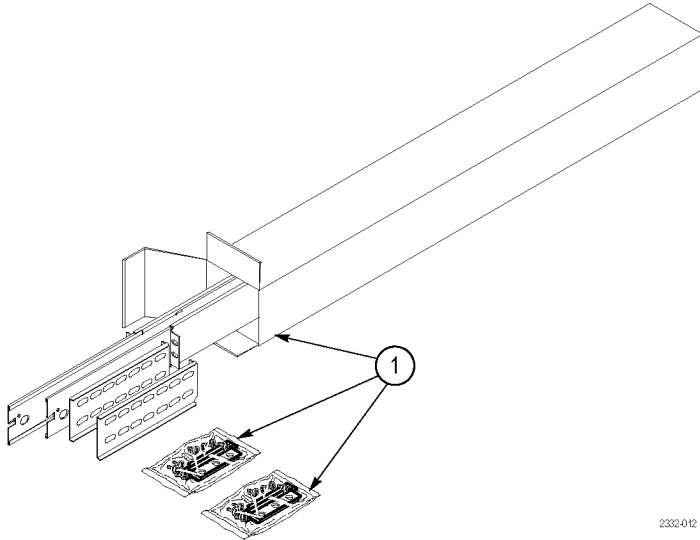

Figure 1: Rackmount kit parts (part appearance may vary)

**Table 2: Optional accessories (must be ordered separately)**

Item	Quantity	Part number	Description
1	1 pair	351-1095-00	SLIDE ASSY; PAIR, W/STD HARDWARE KIT AND REAR BRACKET



**Figure 2: Optional accessories**

---

**NOTE.** The rack slides are not part of this kit. They are optional, and must be ordered separately.

---

## Environmental requirements

The following environmental characteristics supersede those listed in the specifications and performance verification sections of the manual for your instrument.

**Table 3: Warranted characteristics**

Characteristic	Description
Temperature	
Operating	0 °C to +50 °C (+32 °F to 122 °F)
Nonoperating	-40 °C to +71 °C (-40 °F to 160 °F)
Humidity	
Operating	High: +30 °C to +50 °C, 5% to 60% relative humidity Low: 0 °C to +30 °C, 5% to 95% relative humidity
Nonoperating	High: +30 °C to +55 °C, 5% to 60% relative humidity Low: 0 °C to +30 °C, 5% to 95% relative humidity

## Clearance requirements

The rack in which the rack adapted instrument is mounted must provide the following clearance requirements:

- At least 219.71 mm (8.65 in) of vertical space
- A minimum width of 488 mm (19.2 in) between the left- and right-front rails in the rack. If possible, consider allowing at least 50.8 mm (2.0 in) on the right side and rear of the instrument for adequate airflow.
- A minimum inside depth of at least 284.23 mm (11.19 in) depth (from rack mounting ear to back of instrument)



**CAUTION.** Adhering to these clearance requirements provides the rack-mounted instrument with enough clearance for air circulation and accommodation of the power cord and mounting hardware. Failure to provide these clearances can result in overheating and can cause instrument faults or failure.

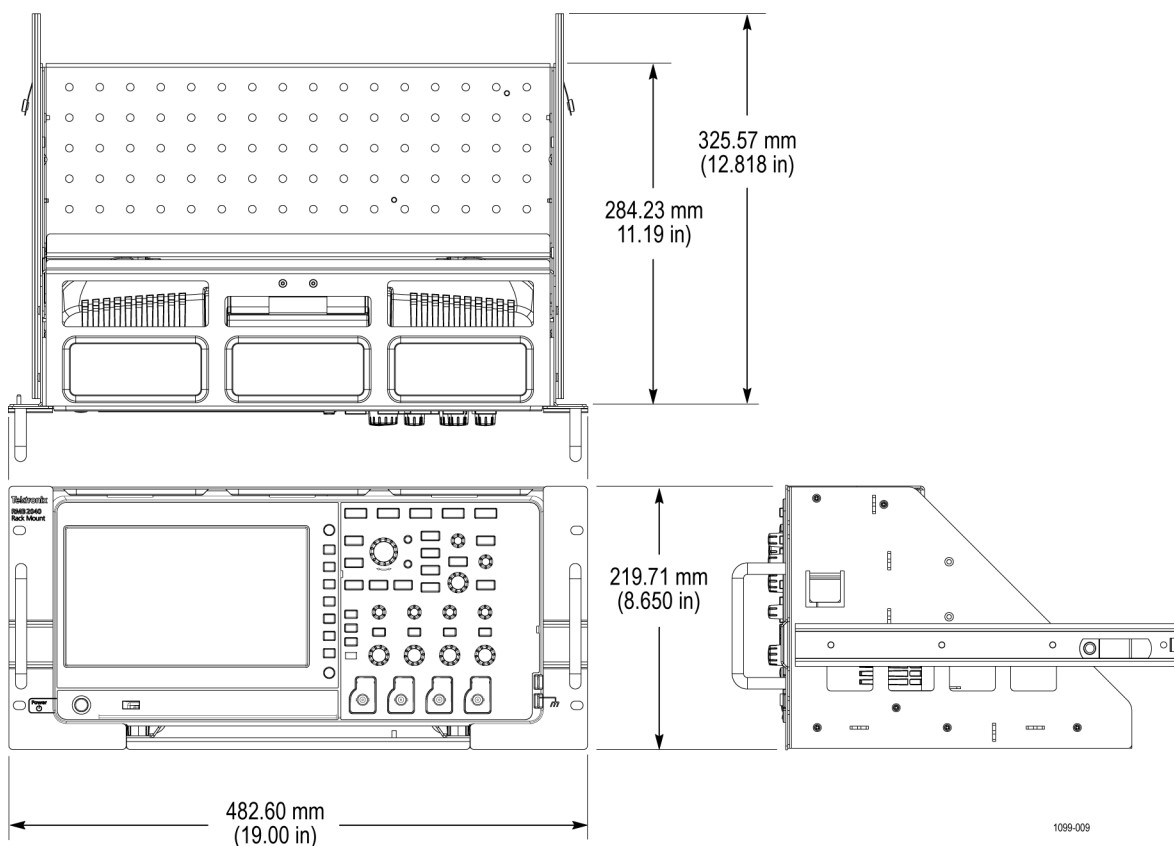

Figure 3: Instrument with rack adapter installed

## Installation instructions

This section contains the procedures needed to rackmount a TBS2xx4 series instrument.

### Minimum tool and equipment list

The following tools are required to attach the rack-adapter kit hardware, install cabling hardware, and mount the rack-adapted instrument into a standard equipment cabinet. All tools are standard tools that are readily available.

**Table 4: Tools required for rackmount installation**

<b>Name</b>	<b>Description</b>
Screwdriver handle (magnetic)	Accepts 1/4-inch hexagonal head driver tips
No. 2 Phillips or PoziDriv tip	Phillips or PoziDriv-driver tip for number 2 size screw heads
Straight tip	Straight screwdriver tip for slotted screw heads
1/4 inch wrench	Wrench or nut driver is used to install slides
Torque driver	6.5 in long shaft; accepts 1/4-inch hexagonal head driver tips



## Install the oscilloscope in the rackmount

This section describes mounting the rackmount parts to the instrument.

1. Install the left and right side brackets to the bottom bracket using three pan head screws (211-1275-00) on each side. Tighten these screws to 8 in-lb. (See Figure 4.)

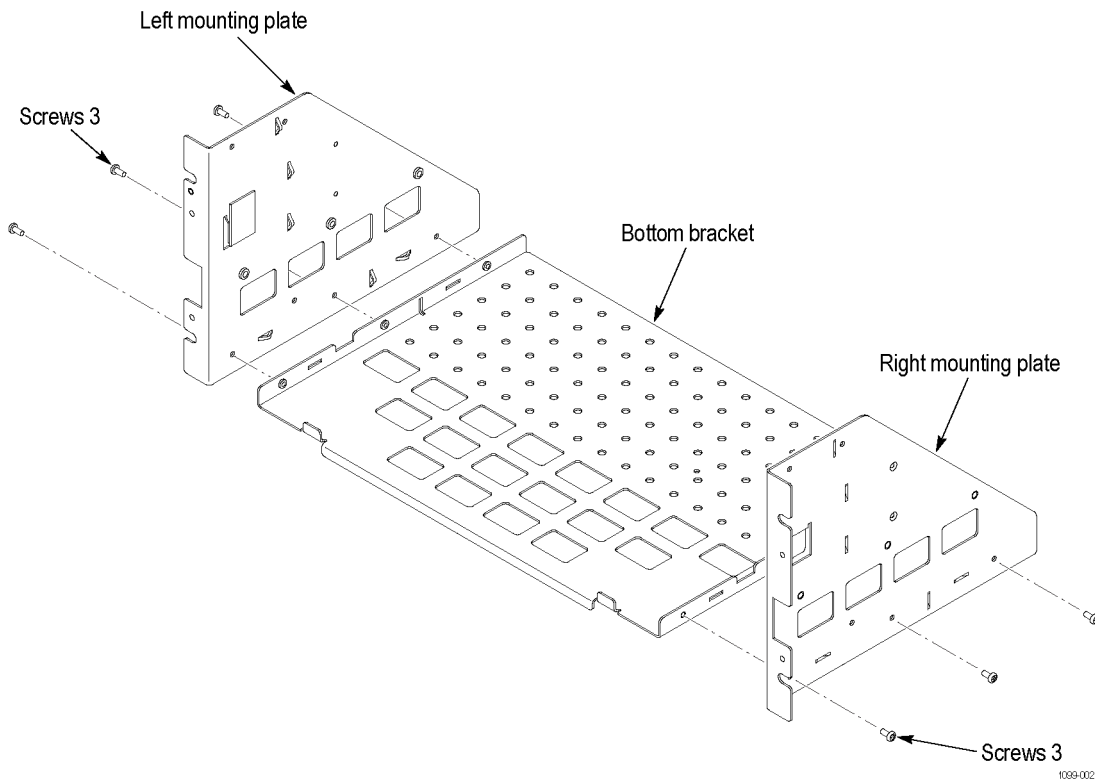

Figure 4: Assembling the left and right mounting plates

2. Install the rear feet bracket on the bottom bracket using two pan head screws (211-1275-00), tightened to 8 in-lb. (See Figure 5.)
3. Place the right faceplate into position, and then install the right handle using two of the flat head screws (212-0043-00), tightened to 16 in-lb. Installing the handle secures the faceplate in place. (See Figure 5.)
4. Repeat Step 3, using the left faceplate and handle. (See Figure 5.)

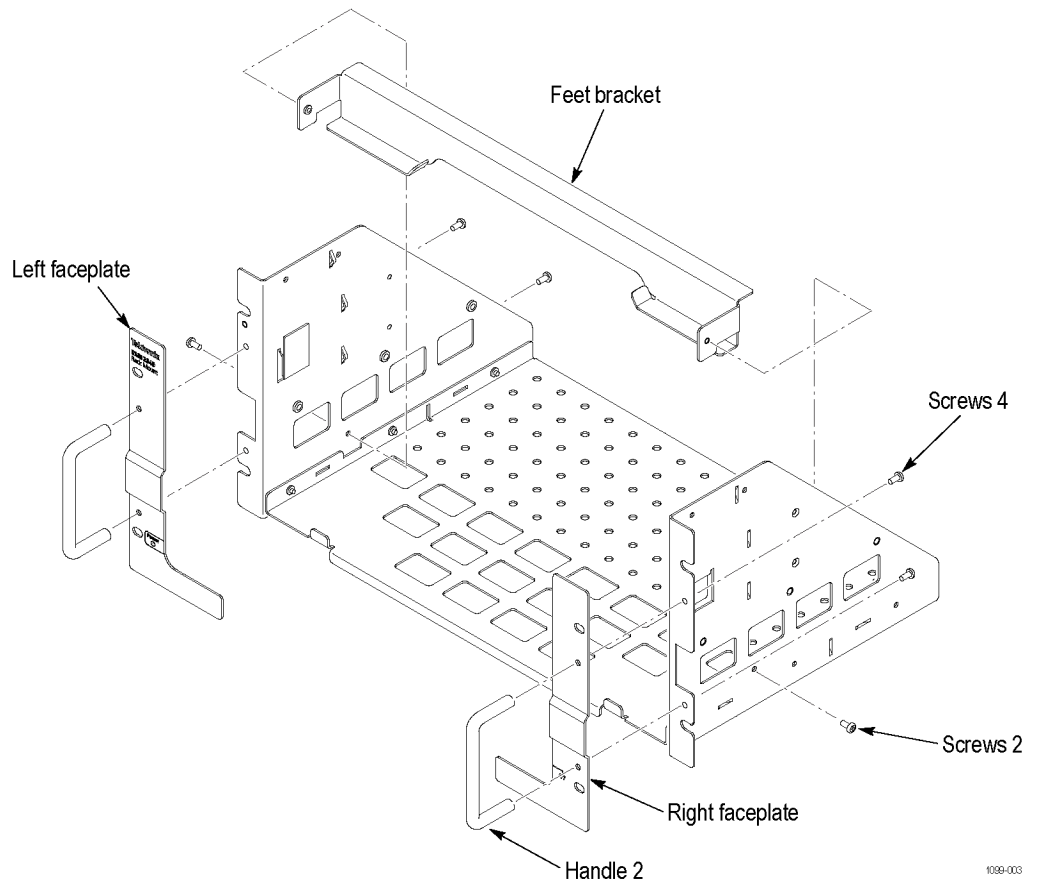
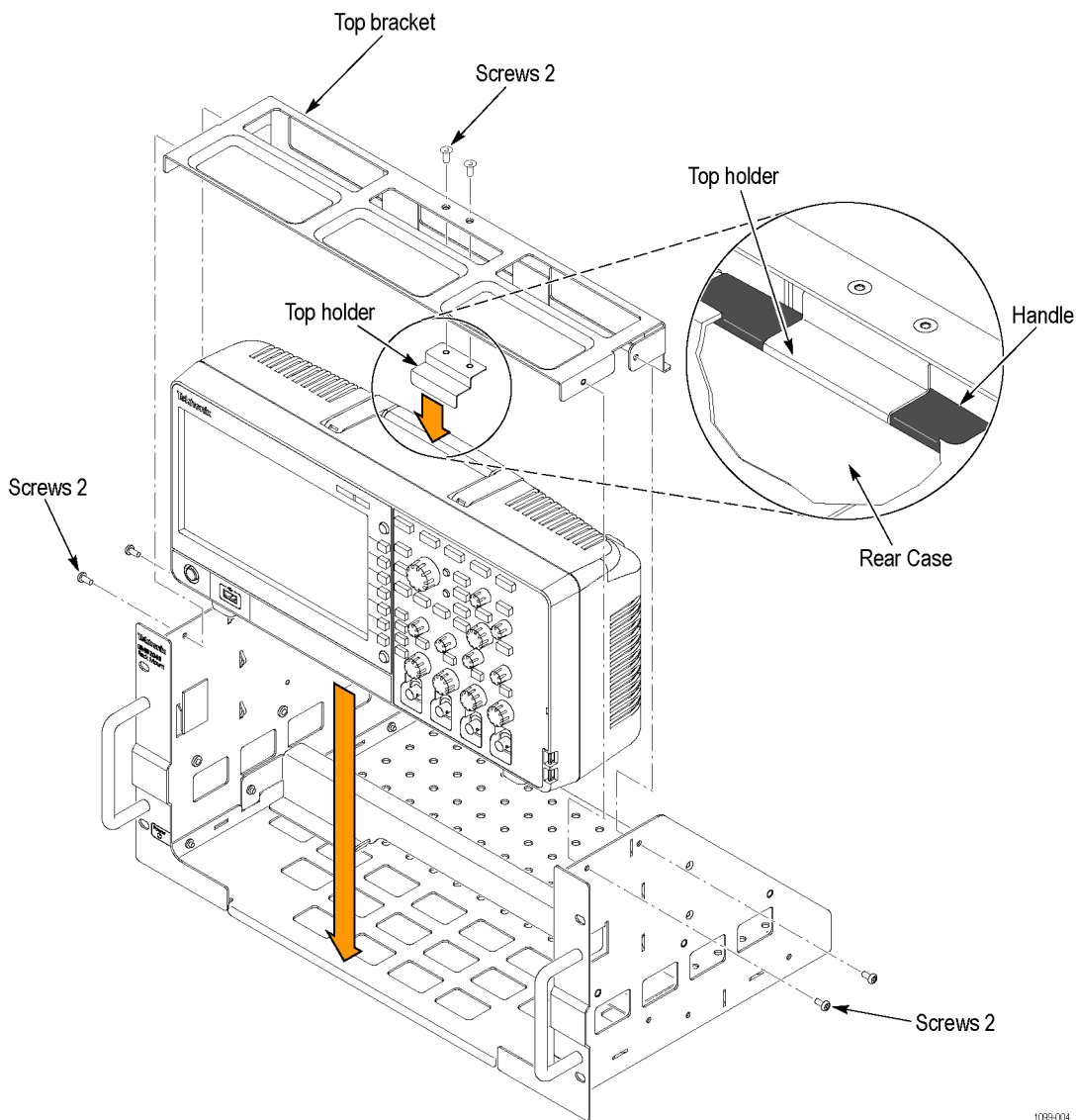

Figure 5: Installing the faceplates and feet bracket

5. Place the oscilloscope into the rackmount frame. Position the oscilloscope's rear feet against the rear feet bracket. The front of the oscilloscope will extend slightly beyond the two faceplates. (See Figure 6.)
6. Install top holder into top bracket with two flat head screws (211-0538-00). (See Figure 6.)
7. Install the top bracket by sliding it into place from the back. Make sure the vertical side of top holder inserts into the gap, which is formed by the rear case and black rubber of handle. (See Figure 6.)
8. Attach the top bracket to the side brackets with two pan head (211-1275-00) on each side. (See Figure 6.)



1099-004

**Figure 6: Installing the instrument in the enclosure**

## Rackmount the oscilloscope without rack slides

If you did not order the optional rackmount slides, you may install the oscilloscope into an equipment rack by following this procedure:



**WARNING.** To prevent the instrument from tipping or falling on the installers, this procedure should be performed by two or more people.

1. Select the appropriate screws for your equipment rack from the kit; 10–32, 12–24, M5, or M6. Assemble them with the recessed and flat washers as shown:

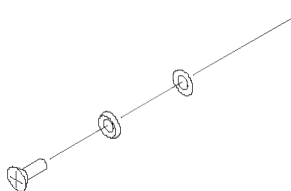

Screw type	Use this flat washer
10-32	0.625 in. OD
12-32	12 mm OD
M5	0.625 in. OD
M6	12 mm OD

2332-018

**Figure 7: Rackmount hardware**

2. Standard equipment racks use one of two mounting hole spacing methods. Both methods use mounting holes spaced 0.5 inch apart, separated by a 1.25 inch gap. One method (A) places an additional mounting hole in the middle of the 1.25 inch gap (at 0.625, or 5/8, inch); the other method (B) does not. (See Figure 8.)
3. Select two 0.5 inch-spaced holes in the front rail. Verify that there are clearances of 1.5 inch above the upper mounting hole and 5.50 inch below the lower mounting hole. (See Figure 8.)
4. Slide the oscilloscope into the equipment rack so that the pin extending back from the left side, just below the upper mounting hole, goes into the lower of the 0.5 inch-spaced holes in the front rail. This pin is a locating guide, and also an aid to holding the oscilloscope in place while securing the oscilloscope to the instrument rack. (See Figure 8.)

- Use the screws and washers from step 1 to attach the oscilloscope to the instrument rack.

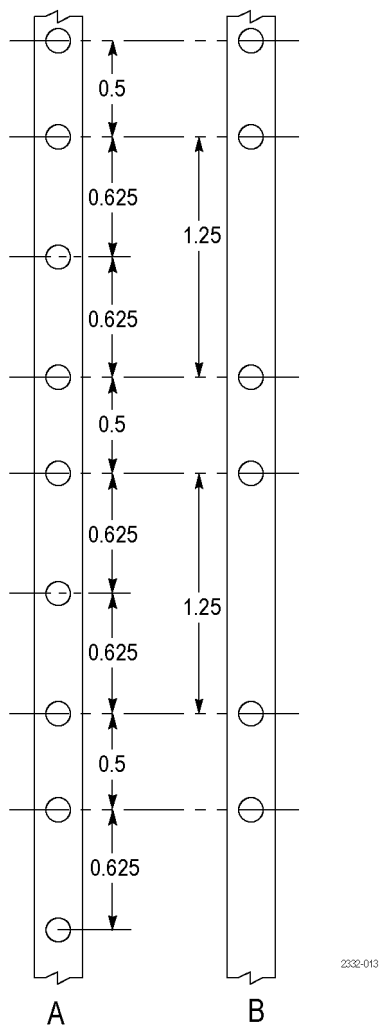

Figure 8: Standard rack hole spacing

## Rackmount the oscilloscope using rack slides

If you ordered the optional rackmount slides, this procedure assembles and installs the slide-out tracks in the equipment rack, and then installs the oscilloscope in the rack.

The slide-out tracks permit the oscilloscope to be extended out of the rack for rear-panel and connector maintenance without removing the instrument from the rack.



**WARNING.** To prevent the rackmounted instrument from tipping forward on the operator, install the instrument so that the operator is able to access all of its rear devices without pushing down on the instrument.

*Verify that the rack does not become unstable with the instrument fully extended. Do not leave the instrument extended when finished accessing the rear panel.*

---

### Install track assembly

---

**NOTE.** The rack hardware kit contains hardware for mounting the instrument in several configurations. Not all of the hardware in the kit is needed.

---

1. Remove the front (chassis) section of each of the two tracks.

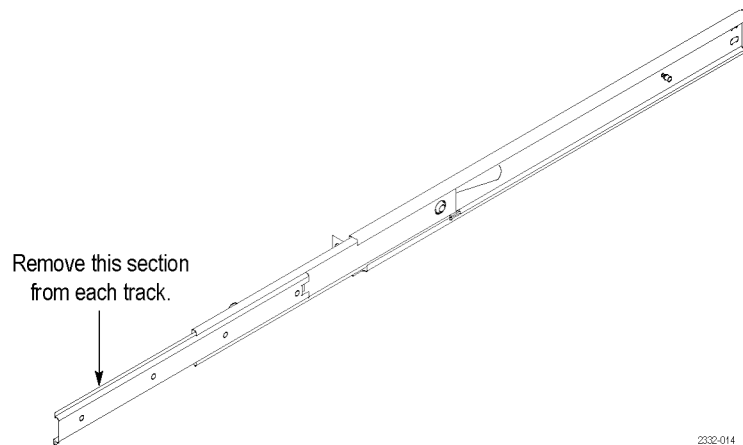

2332-014

Figure 9: Removing front track section

2. Install the left and right side track sections on the instrument using six of the 10-32 x 3/8 inch slotted screws. Tighten to 28 in-lb.

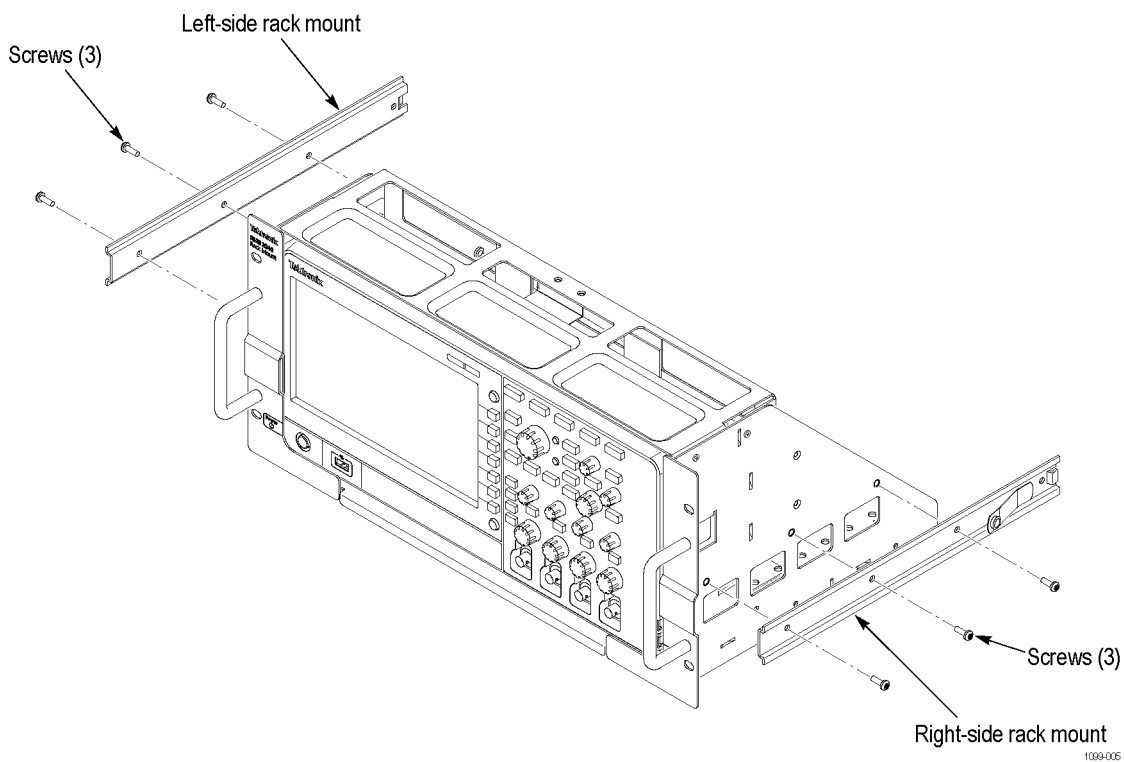

Figure 10: Installing the left and right side track sections



**WARNING.** To be sure that the rackmount track locks, make sure the track button latches are oriented correctly: the right-side latch is located toward the bottom of the rackmount panel and the left-side latch is located toward the top of the rackmount panel. If the button latches are not oriented correctly the instrument could slide from the rack, which could cause personal injury or damage to the instrument.

---

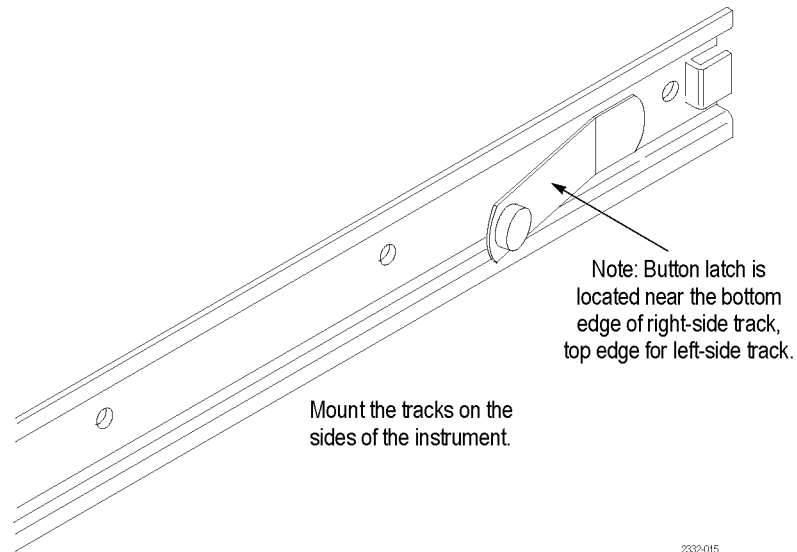

Figure 11: Track orientation



**Assemble the slide-out track**

1. Measure the distance between the front and rear rail of the equipment rack.
2. Align the rear bracket to the right slide-out track as shown.

---

**NOTE.** The rear bracket has multiple pairs of mount-through holes. When aligning the bracket and track, be sure to select a pair of holes that mount the rear bracket so that the flange-to-flange distance matches the distance between the front rail and rear rail measured in step 1.

---

3. Using a screwdriver with a number two Pozidriv tip, attach the rear bracket to the right slide-out track using two screws (10-32) and a bar nut as illustrated. Leave the screws loose to adjust the overall length of the slide-out track assembly when installing it in the rack.
4. Step-Repeat steps 2 and 3 to assemble the left slide-out track assembly.

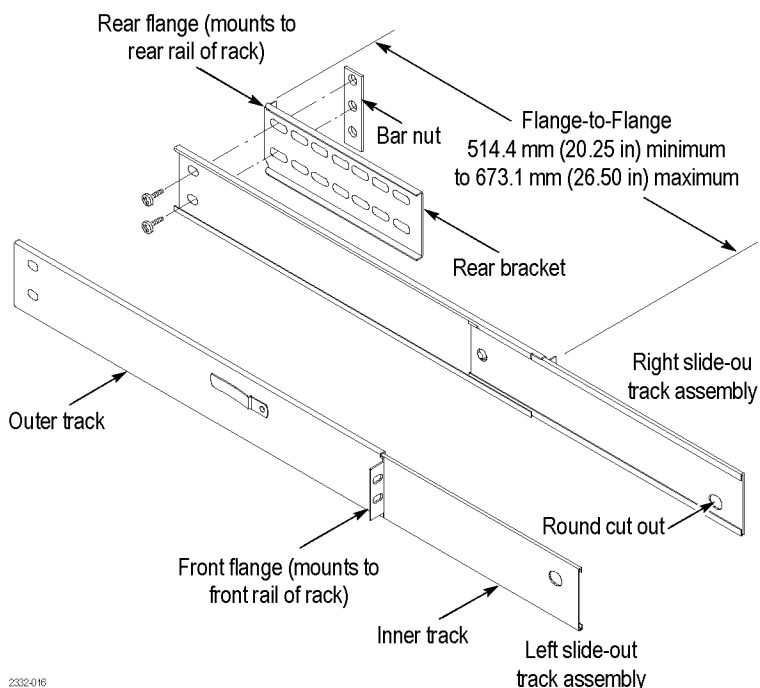
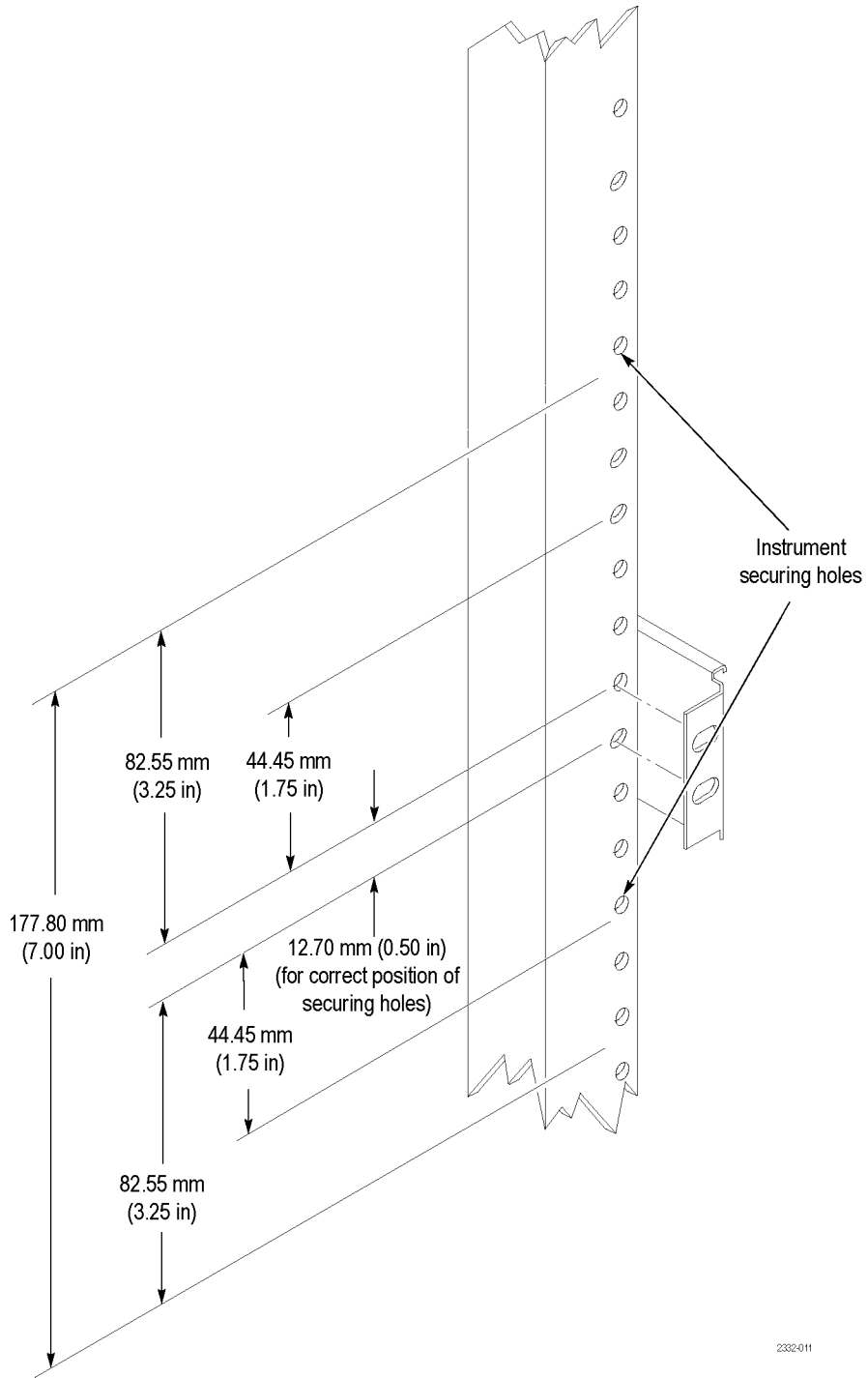

Figure 12: Slide track assembly

**Mount the slide-out track assemblies**

1. Select the mounting position in the rack. Select two 0.5 inch-spaced holes in the front rail, and verify that there is a 3.25 inch clearance above and below those mounting holes.



**Figure 13: Rackmount positions**

2. Select the mounting method according to the rack type:

- To mount the slide-out tracks with their front and rear flanges outside the front and rear rails, use the mounting method A. Add a bar nut to the installation only if the rails have untapped holes.
- To mount with front and rear flanges inside the rails, use the mounting method B. This mounting method assumes untapped holes.

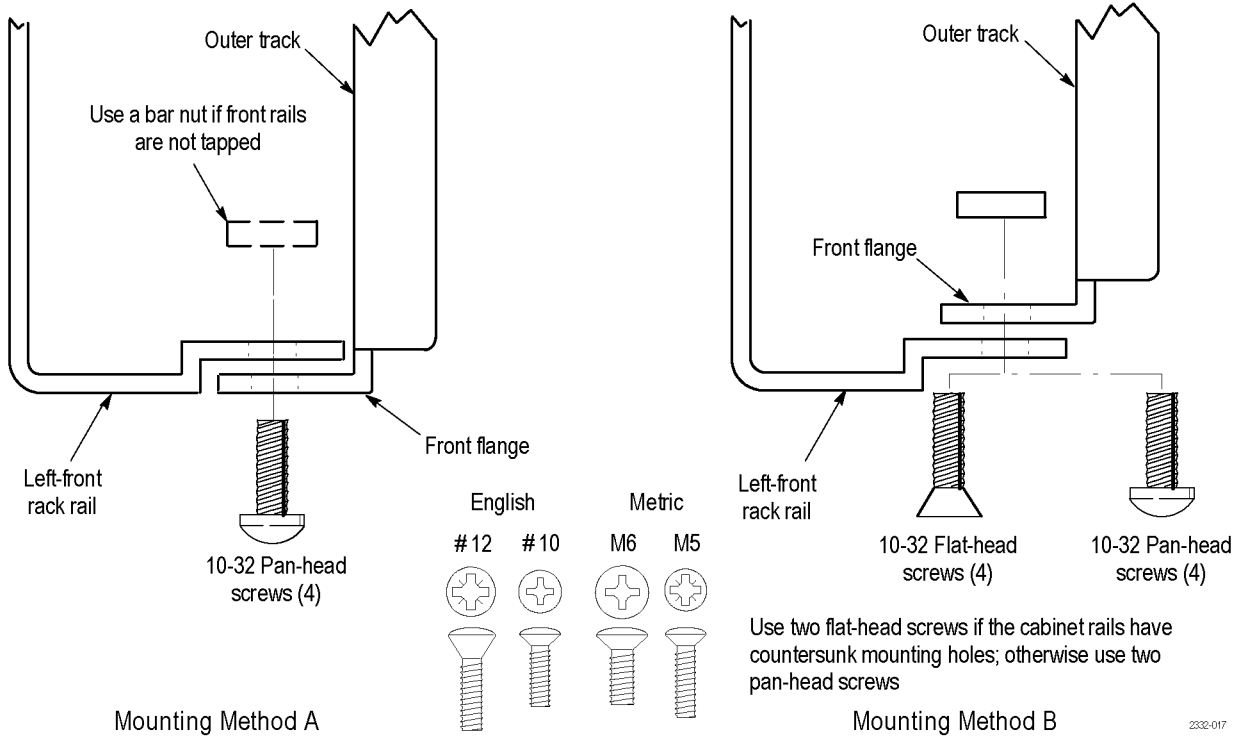

Figure 14: Installation of slide-out track assemblies in rack (top view)

3. Install in rack:
  - Using the method and hardware determined in step 2, attach the right slide-out track assembly to its front and rear rails. The screws should be fully, but lightly, seated so that you can adjust the hardware later.
4. Fix the length of the slide-out track assembly:
  - Tighten the screws left loose (step 3 in *Assemble the slide-out track* section) to 28 inch-lb, to fix the front to rear flange spacing of the slide-out track assembly.
5. To mount the left slide-out track assembly, repeat steps 3 and 4 to mount the left slide-out track assembly.

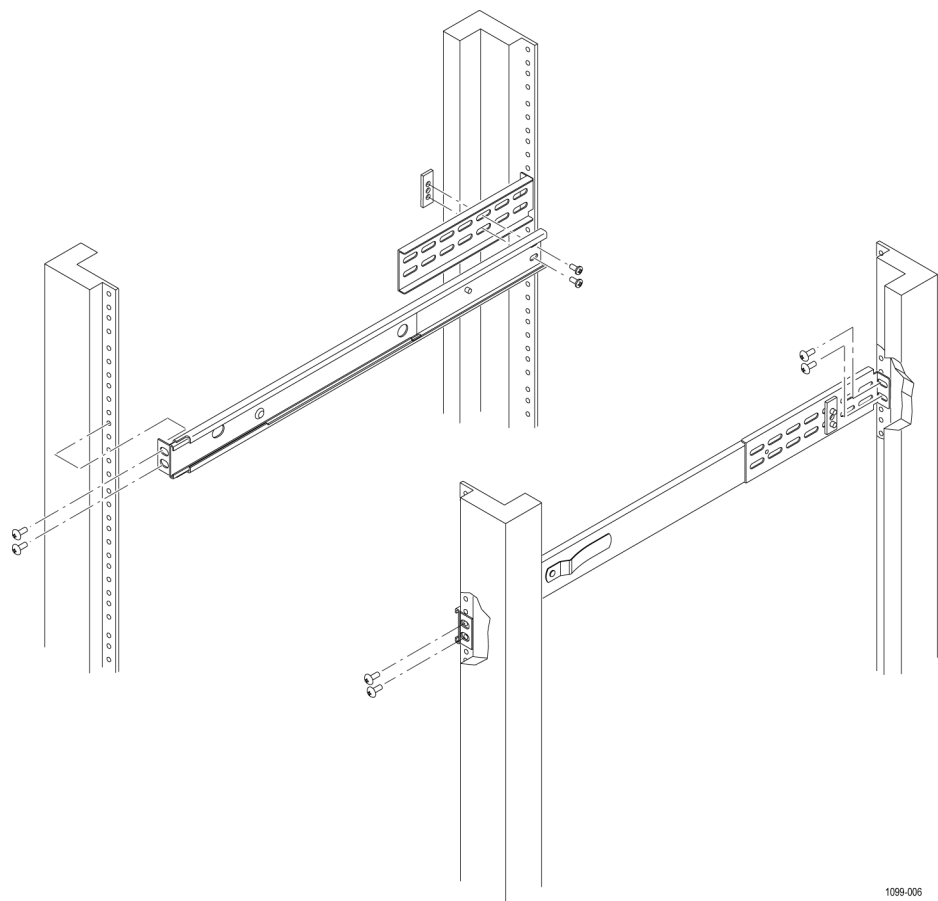

Figure 15: Installing the slide-out track to mount stand

## Mount the oscilloscope into the rack

Use the following instructions to install and secure instrument into the rack.



---

**WARNING.** *To prevent the instrument from tipping or falling on the installers, two or more people should install this instrument into the rack cabinet.*

*After completing the installation procedure, the installers should verify that the instrument and rack cabinet will not tip forward while the instrument is in the extended position.*

---

1. Install the instrument:
  - a. Working from the front of the rack, slide the inner track of each slide-out track assembly until it extends out the front of the rack. Continue to slide them out until they lock.
  - b. Insert the left and right tracks that extend from the rear of the instrument into the ends of the tracks just extended. Make sure the tracks mounted on the instrument slip inside the inner tracks extended earlier.
  - c. Slide the instrument backward until it stops.
  - d. Push to release the button latches, located outside of each track, and continue to slide the instrument all the way into the cabinet.
2. Level the rackmounted instrument:
  - a. Tighten the four screws that were left loose at the rear of the rack (step 3 in *Assemble the slide-out track* section), and then pull the instrument part way out of the rack.
  - b. Be sure that the four screws that were left loose at the front of the rack are loose enough to allow the slide-out track assemblies to seek their normal positions.
  - c. Retighten the four screws and push the instrument all the way into the rack. If the tracks do not slide smoothly, readjust the level using the method just detailed.
  - d. When leveling is completed, tighten the 10-32 screws using 28 inch-lb of torque.

3. Attach the instrument to the rack:
  - a. Select four of the appropriate screws for your equipment rack from the kit; 10-32, 12-24, M5, or M6.
  - b. Attach the instrument in the rack using the screws selected, with the recessed washers and flat washers.

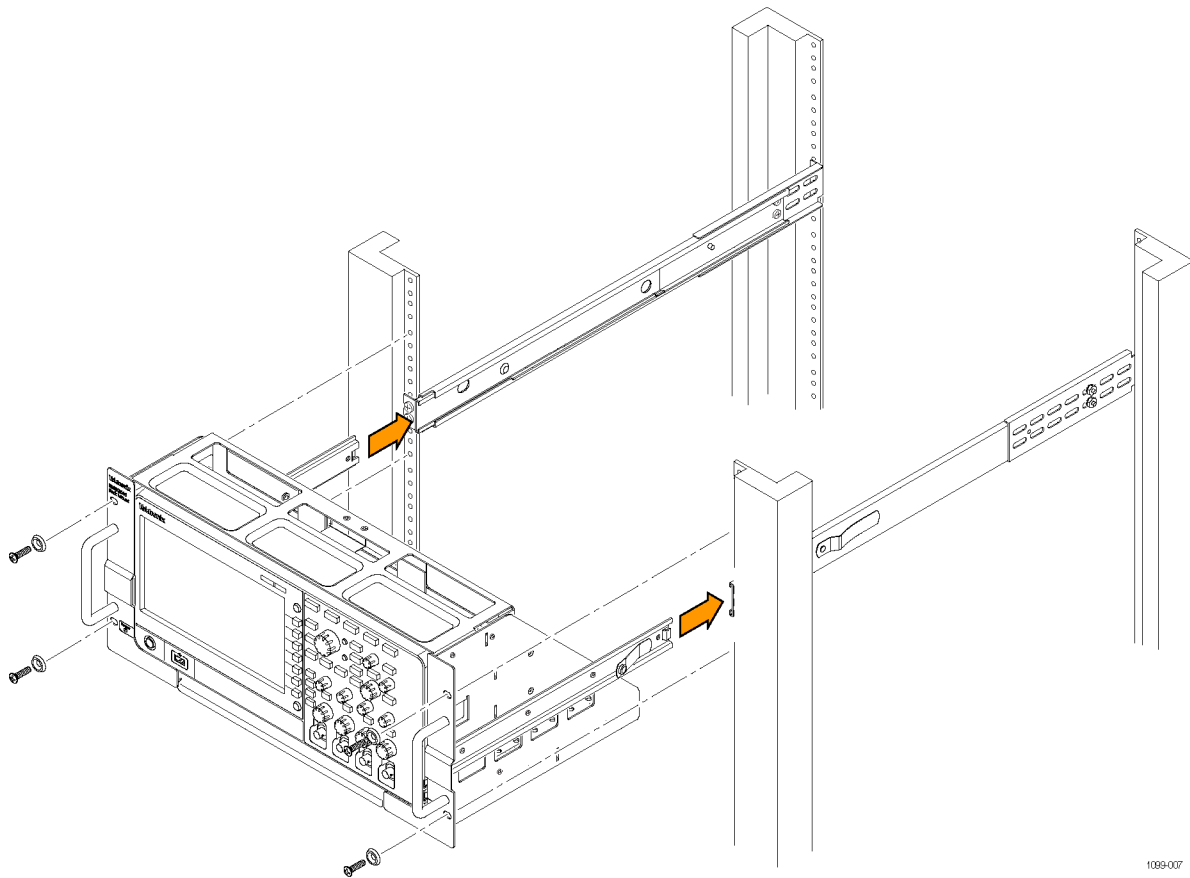

Figure 16: Securing the instrument to mount stand



**WARNING.** To prevent the rackmounted instrument from sliding forward and causing personal injury or instrument damage, always attach the instrument to the rack if the rack is moved (for example, if the rack is repositioned or relocated to another room)

**Mounting optional accessories**

The bottom bracket has holes for mounting optional accessories. For example, Tek-USB-488 to USA adapter mounted to the back support. Optional accessories may be mounted with screws or nylon straps to attach them.

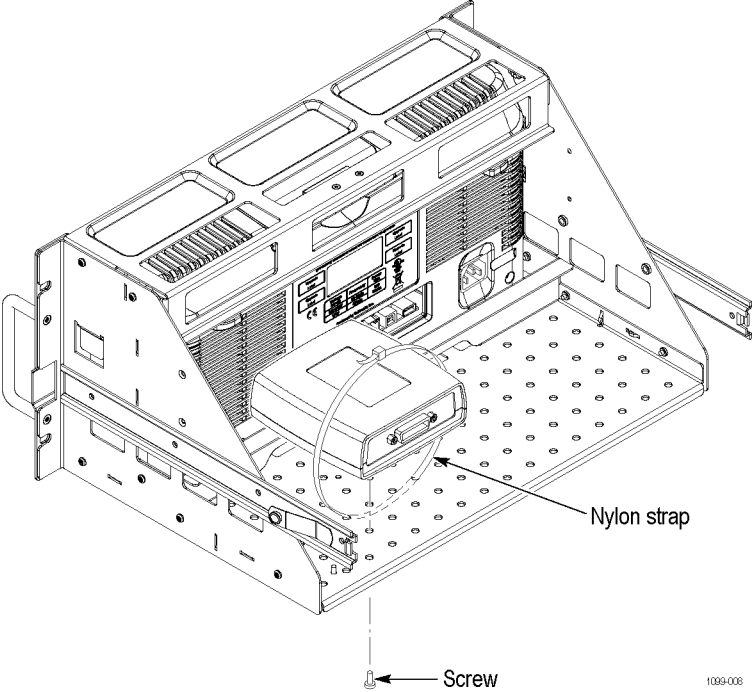

**Figure 17: Mounting optional accessories to bottom bracket**