

Original Instructions
Instrucciones originales
Consignes originales

Model AC1234-4



Recover, Recycle, Recharge Machine
for R1234yf A/C System

Replace the Oxygen Sensor in the Refrigerant Identifier

The refrigerant identifier in the machine contains a replaceable oxygen sensor that can affect the way the machine works if the sensor is not functioning correctly.

- If the machine displays the following message, immediately replace the oxygen sensor:

OPERATING TIME OF THE IDENTIFIER AND UNIT ARE LIMITED
REPLACE ID O2 SENSOR SOON
UNIT WILL BECOME NONFUNCTIONAL

- If the machine displays the following message, the oxygen sensor has expired. Neither the identifier nor the machine is able to recover or add refrigerant to the internal tank.

ANALYZER ERROR 6
O2 SENSOR FAILURE
SENSOR MUST BE REPLACED
UNIT WILL NOT RECOVER OR ALLOW TANK FILL
SEE MANUAL

Replacement Procedure

1. Disconnect the machine from its power source.
2. Remove the oil bottle, and remove the four screws holding the shroud. See Figure 13. Hang the shroud on the back of the machine.
3. Disconnect the wire harness, USB connector, and sample hose from the identifier. See Figure 14.
4. Remove the two screws holding the identifier to the machine, and remove the identifier.
5. Carefully pry the oxygen sensor cap from the housing. Gently pull on the cap and wires until the connector exits the housing.

CAUTION: The wire connected to the cap is connected internally to the identifier. To prevent equipment damage, do NOT pull on this wire.

Remove four screws holding shroud.

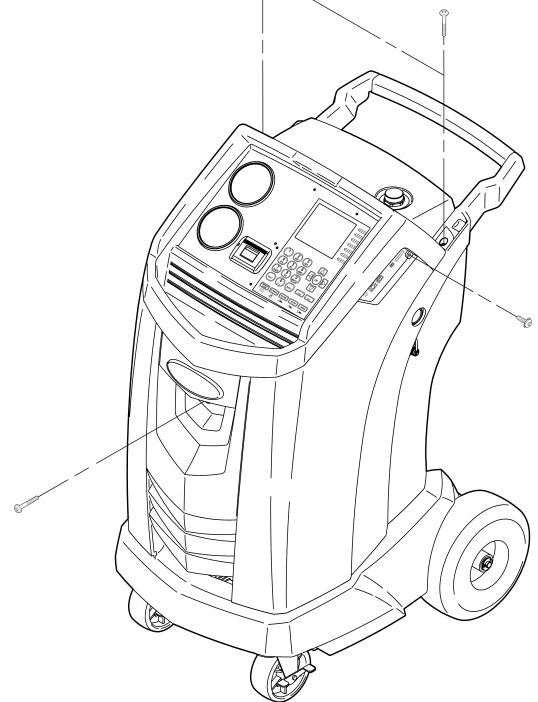

Figure 13

Disconnect wire harness, USB connector, and sample hose.

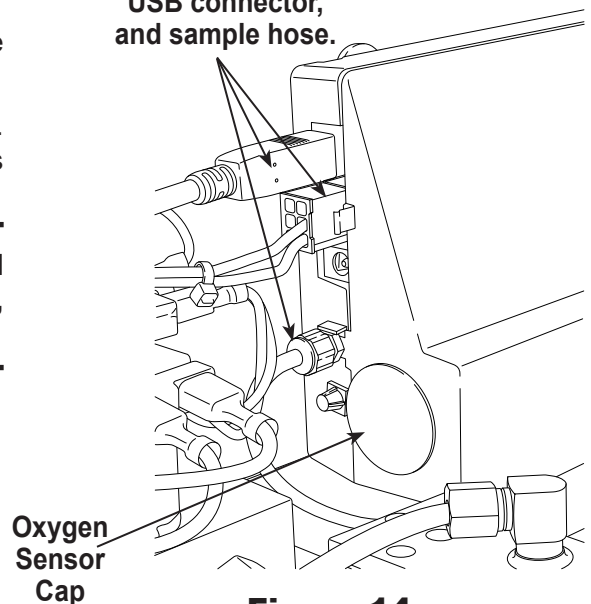

Figure 14

Maintenance

6. Disconnect the wire harness at the connector by pressing on the center tab. Pull the connectors apart. See Figure 15.
7. Move the cap and harness aside. Hold the lead from the sensor, and use a flat-blade screwdriver to unthread and remove the oxygen sensor. See Figure 16.
8. Remove the pink protective film from the threaded end of the new oxygen sensor.
9. Install the new oxygen sensor, using the screwdriver to thread it into place. Tighten the sensor to 4 in. lb.
10. Reconnect the lead at the connector, and tuck the wires into the opening.
11. Replace the cap and push until it “clicks” into place. Install the identifier onto the machine, and reconnect the wire harness, USB connector, and sample hose.
12. Verify the wiring is not binding, and replace the shroud.

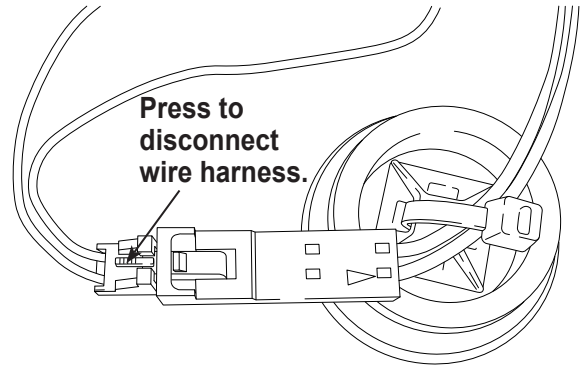

Figure 15

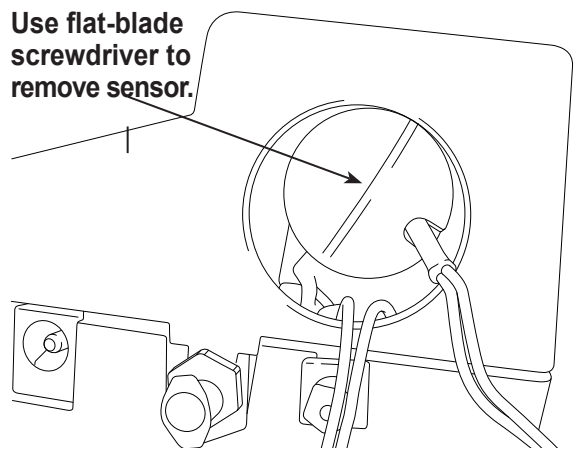

Figure 16

Refrigerant Identifier

The refrigerant identifier samples refrigerant going into the ISV to verify that it is R1234yf and not contaminated. Replace the sample hose assembly during every filter change and also if prompted by an error message saying that the hose is clogged. See Figure 17.

1. Disconnect the existing sample hose assembly between the solenoid and the refrigerant identifier, and install a new sample hose assembly.

Note: If the filter is any color but white, the filter needs to be replaced also.

2. Pull the filter out of the brackets while removing the barbs from the rubber connectors.
3. Install a new filter with the arrow pointing upward as shown. Push the filter barbs into the rubber connectors.
4. Install the shroud on the machine and switch the power **ON**.

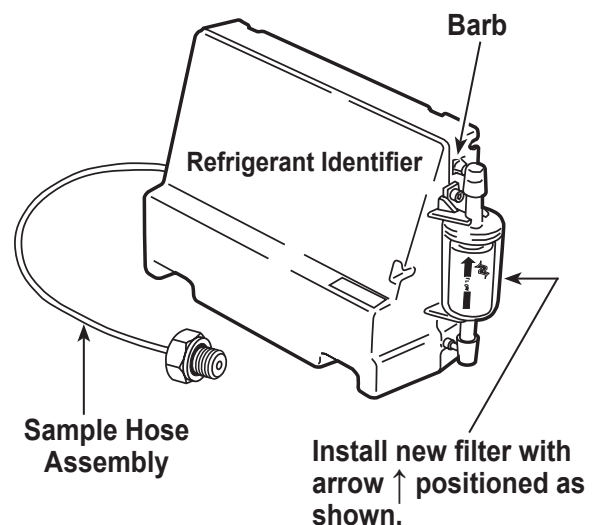

Figure 17

Replace the sample hose assembly during every filter change.

Replace Service Hoses and/or Service Couplers

Ensure pressure has been removed from service hoses before disconnecting a hose or coupler from the machine. Pressure gauges must read at or below 0 psig.

If pressure exists, recover the refrigerant from the hoses before disconnecting a hose or coupler.

1. The machine performs a 30 second vacuum to ensure hoses are empty.
2. The machine displays

Disconnect old hoses and
replace with new hoses
Press OK to continue
Press ESC to exit

Remove and replace old service hoses. Press **OK**.

3. The unit directs the user to connect hoses to the storage ports and press **OK** to begin unit conditioning.
4. A vacuum is performed on the unit until excess air has been removed from the service hoses.
5. The machine is now ready to use.

Tank Fill Hose Filter Service

The tank fill hose at the rear of the machine (see Figure 18) contains a filter that can be cleaned when it appears that refrigerant flow is restricted.

When the machine senses low flow, it can display one of the following messages:

- SOURCE TANK EMPTY, but the source tank is known to contain refrigerant, connections are secure, and the source tank valve is open.
- REPLACE IDENTIFIER FILTER, but the refrigerant identifier filter is known to be unrestricted, the source tank contains refrigerant, connections are secure, and the source tank valve is open.

The tank fill hose filter might be plugged.

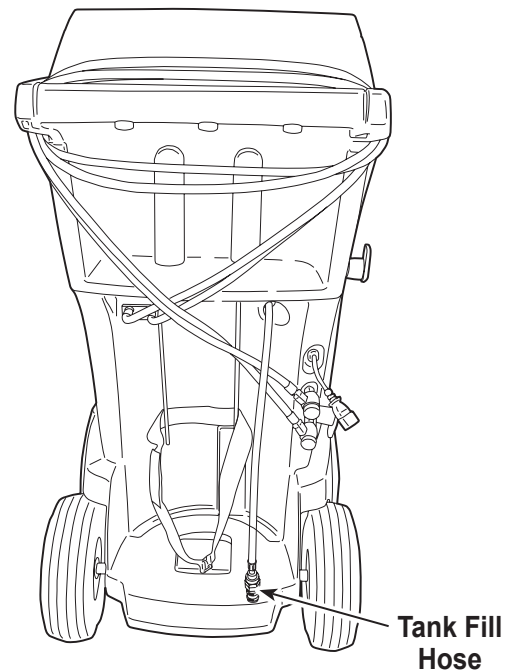

Figure 18

Maintenance

Cleaning the Tank Fill Hose Filter

1. First ensure that pressure does not exist in the line. Disconnect the external source tank, and perform a manual tank fill to capture any refrigerant in the line.
2. Disassemble the tank fill hose at the filter housing as shown in Figure 19.
3. Remove the filter. The recommended method to remove debris from the filter is by using air pressure.

Note: If a solvent is used, allow adequate drying time before reassembly.

4. After the filter has been installed back into the filter housing, torque the housing assembly to 8.5 N•m (6 ft. lb.).

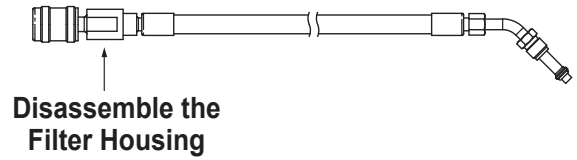



Figure 19

Replacement Parts

Contact Robinair Customer Service (1-800-533-6127) for more information regarding the replacement parts listed here.

Component	Replacement Part No.
Calibration Weight	16214
Filter	34724
Oil Drain Bottle	19100
Printer	30038
Printer Paper (3 rolls)	34214
LP Service Coupler	18122
HP Service Coupler	18123
Service Coupler Set (high-side [red] and low-side [blue] couplers)	18124
Hose Set without Couplers (high-side [red] and low-side [blue])	71234
Service Hose without Coupler (low-side, blue)	70123
Service Hose without Coupler (high-side, red)	70124
Vacuum Pump Oil (pint)	13119
Vacuum Pump Oil (quart)	13203
Vacuum Pump Oil (gallon)	13204
Vinyl Dust Cover (optional)	17499
Identifier Filter	16913
Identifier Oxygen Filter	16916
Identifier Sample Hose	16106
Tank Fill Hose Filter	10233

 **WARNING:** To prevent personal injury, use only those repair parts called out in this parts list. Items found in this parts list have been carefully tested and selected by Robinair.

Glossary

A/C System : The vehicle air conditioning system being serviced.

Evacuation : Moisture and other non-condensables are removed from an A/C system by a vacuum pump.

Internal Storage Vessel (ISV) : The refillable refrigerant storage tank designed specifically for this machine; 9.5 kg (20.94 lb) capacity.

Leak Test (Vacuum) : Components containing refrigerant are evacuated and monitored for pressure rise, which could indicate a leak.

Machine : Model No. AC1234-4.

Leak Check : Components containing refrigerant are pressurized and monitored for pressure decay, which could indicate a leak.

Recovery / Recycling : Refrigerant is recovered from an A/C system, filtered, and stored in the ISV.

Refrigerant : R1234yf.