

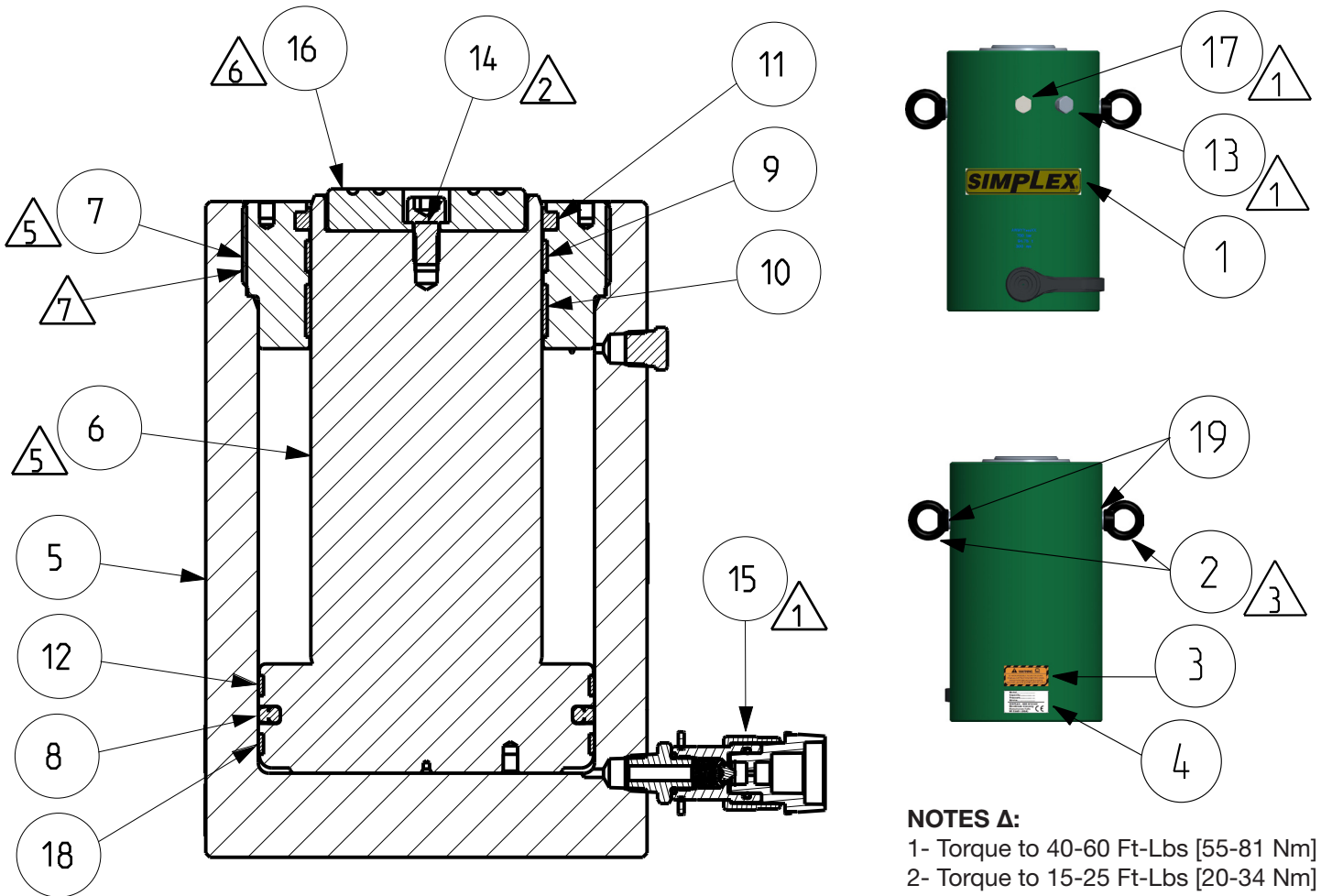

# Repair Parts Sheet

RCG CYLINDERS, 100 TON MODELS

Parts Sheet Number	Revision	Revision Date	Product version
RRCG100	Rev. B	07/2020	A



**NOTES Δ:**

- 1- Torque to 40-60 Ft-Lbs [55-81 Nm]
- 2- Torque to 15-25 Ft-Lbs [20-34 Nm]
- 3- Torque to 80-100 In-Lbs [9-11 Nm]
- 5- Apply oil wax before assembly
- 6- Apply oil wax after assembly
- 7- Apply molykote grease CU7439PLUS

■ = Indicated parts only available in Seal Kit RCG100K

Nr.	DESCRIPTION	QTY	RCG1006	RCG10012
1	Simplex Decal	1	■	■
2	Eyebolt Rotating	2	24D0210	24D0210
3	Warning Decal	1	■	■
4	Characteristics Decal	1	■	■
5	Base	1	52F1012	52F1001
6	Plunger	1	53F1151	53F1140
7	Stop Ring	1	55E0219	55E0212
8	Piston Seal	1	■	■
9	Glide Ring-Rod	1	■	■
10	Glide Ring-Rod	1	■	■

Nr.	DESCRIPTION	QTY	RCG1006	RCG10012
11	Scraper	1	■	■
12	Glide Ring-Piston	1	■	■
13	Plug	1	BSS6349D	BSS6349D
14	Screw-SHCS. HEX	1	CBE1221028-1A	CBE1221028-1A
15	Female coupler	1	DB2771034	DB2771034
16	Saddle	1	HCL100045	HCL100045
17	Plug	1	R515245-2	R515245-2
18	Glide Ring Piston	1	■	■
19	Washer-Flat	2	CAE1100108-1A	CAE1100108-1A