

To Protect Your Warranty, Use Only ENERPAC Hydraulic Oil.

Enerpac recommends that all kit components be installed to insure optimum performance of the repaired product.

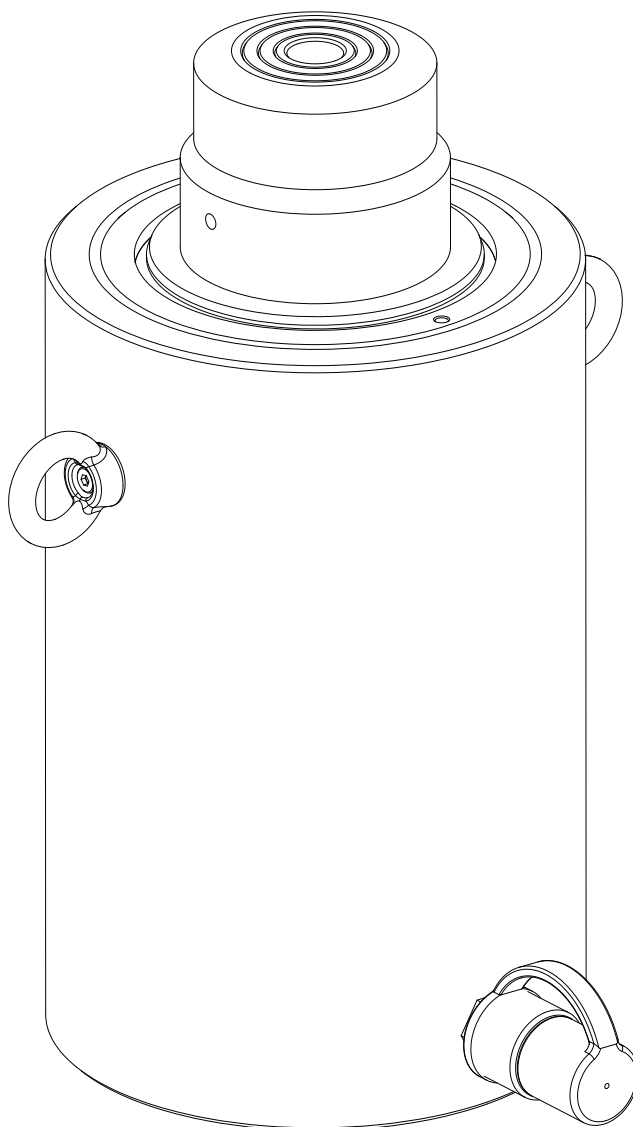
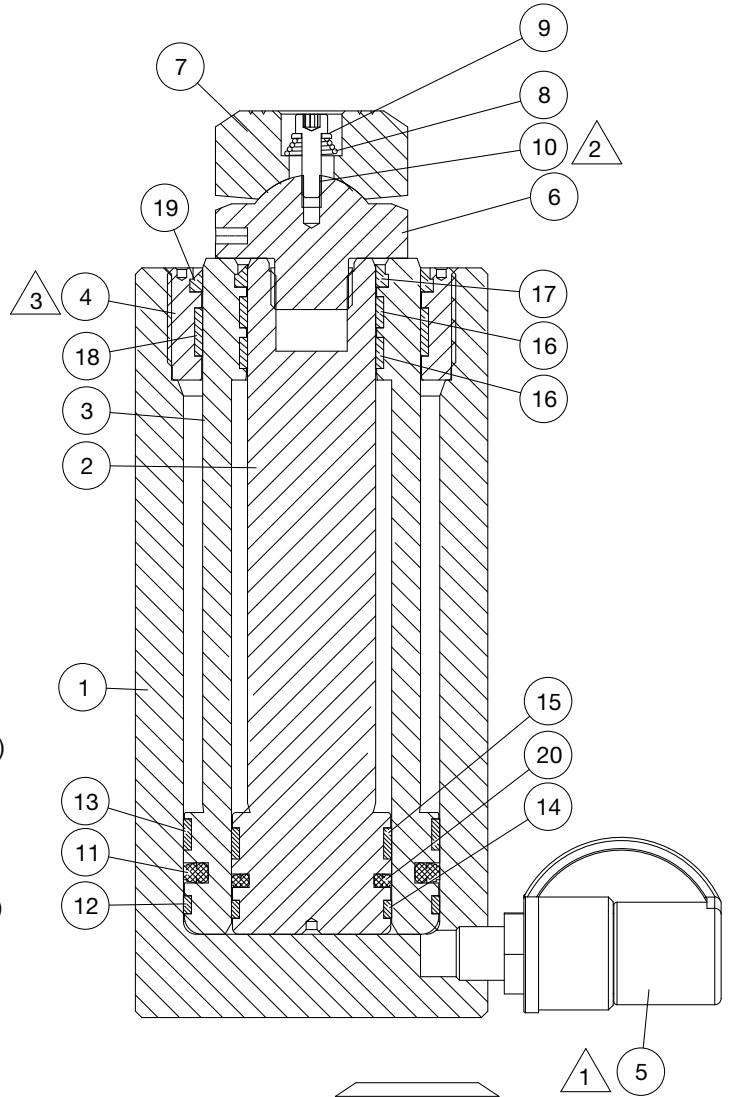
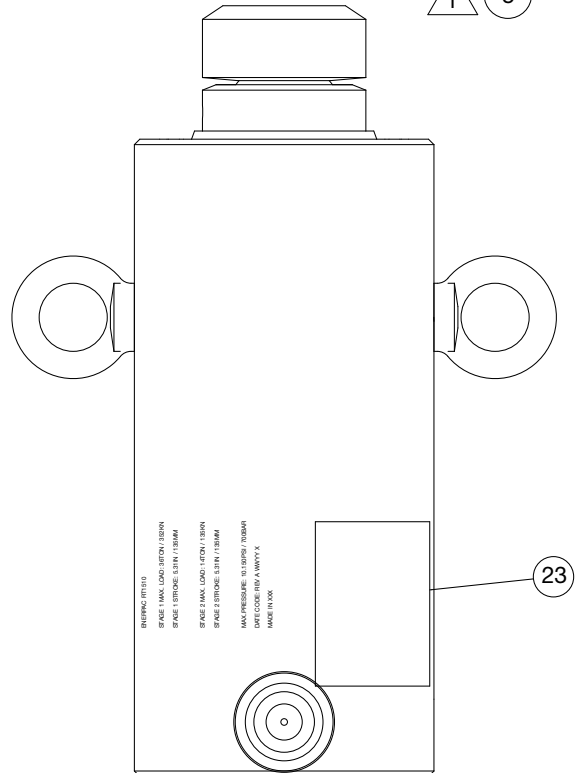
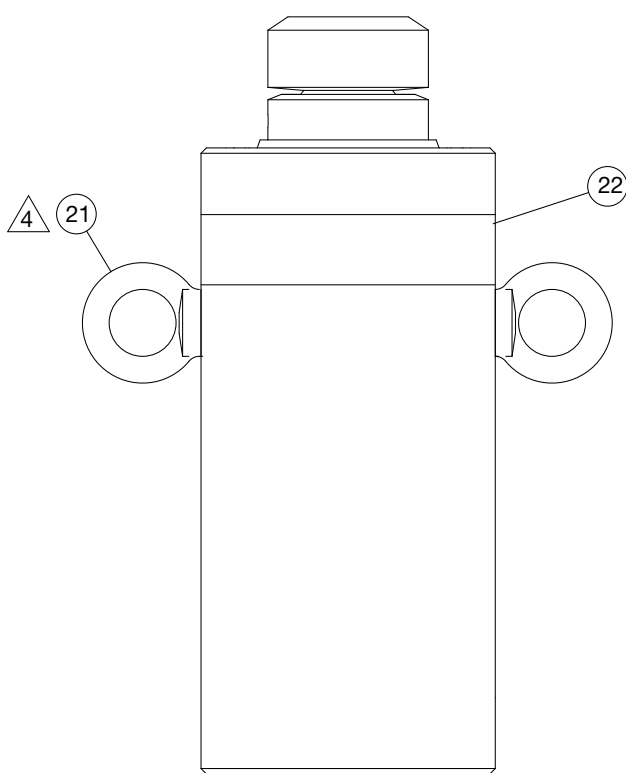

Figure 1 - RT-1510 Exploded View



NOTES: (UNLESS OTHERWISE SPECIFIED)

- 1 TORQUE TO 40-60 FT-LBS (55-81 Nm)
- 2 TORQUE TO 11-18 IN-LBS (1-2 Nm)
- 3 TORQUE TO 140-160 FT-LBS (190-217 Nm)
- 4 TORQUE TO 40-50 IN-LBS (3.5-5.5 Nm)



Parts List for Figure 1			
Item Number	Part Number	Description	Qty.
1	N/A	Base RT-1510	1
2	N/A	Plunger 1 RT-1510	1
3	N/A	Plunger 2 RT-1510	1
4	B170020044-20	Stop Ring RT-1510	1
5	CR400	Female Coupler	1
6	B170020045-21	Tilting Saddle Base RT-1510	1
7	B170020045-31	Saddle RT-1510	1
8	B170020210-20	Spring Cone 18.5 O.D. x 25mm	1
9	CAE1060108-1A	Flat Washer M6	1
10	CCA621028-1A	Screw SHC, M6 x 1.0 - 20mm LG	1
11	★	Piston Seal 80 x 64.5 x 6.3	1
12	★	Bearing Piston 80 x 75 x 5.6	1
13	★	Bearing Piston 80 x 75 x 9.7	1
14	★	Bearing Piston 50 x 45 x 5.6	1
15	★	Bearing Piston 50 x 45 x 9.7	1
16	★	Bearing 40 x 45 x 9.7	2
17	★	Scraper 40 x 48 x 4	1
18	★	Bearing Rod 68 x 73 x 15	1
19	★	Scraper 68 x 76 x 4	1
20	★	Piston Seal 50 x 39 x 4.2	1
21	DB8099667	Eyebolt, Rotating, M6	2
22	★ G424026	Enerpac Decal 5.19 x 1.00	1
23	★ DA5625026	Warning Decal 2.19 x 3.18	1
24	★	Coupler O-Ring (Not Shown)	1
★	RT1510K	Service Kit	
N/A - Not Available			

Parts List for Figure 2			
Item Number	Part Number	Description	Qty.
1	N/A	Base RT-1817	1
2	N/A	Plunger 1 RT-1817	1
3	N/A	Plunger 2 RT-1817	1
4	N/A	Plunger 3 RT-1817	1
5	B170020044-70	Stop Ring RT-1817	1
6	CR400	Female Coupler	1
7	B170020045-70	Tilting Saddle Base RT-1817	1
8	B170020045-20	Saddle RT-1817	1
9	B170020210-20	Spring Cone 18.5 O.D. x 25mm	1
10	CCA621028-1A	SHCS, M6 x 1.0 x 30	1
11	CAE1060108-1A	Flat Washer, M6	1
12	DB8099667	Eyebolt, Rotating, M6	2
13	★	Piston Seal 130 x 114.5 x 6.3	1
14	★	Bearing Piston 130 x 125 x 15	2
15	★	Piston Seal 85 x 69.5 x 6.3	1
16	★	Bearing Piston 85 x 80 x 15	2
17	★	Piston Seal 55 x 44 x 4.2	1
18	★	Bearing Piston 55 x 50 x 9.7	3
19	★	Bearing Rod 45 x 50 x 9.7	2
20	★	Scraper 45 x 53 x 5	1
21	★	Bearing Rod 70 x 75 x 15	1
22	★	Scraper 70 x 78 x 4	1
23	★	Bearing Rod 110 x 115 x 15	1
24	★	Scraper 110 x 122 x 5.5	1
25	★ G425026	Enerpac Decal, 7.38 x 1.75	1
26	★ DA5625026	Warning Decal, 2.19 x 3.18	1
27	★	Coupler O-Ring (Not Shown)	1
★	RT1817K	Service Kit	
N/A - Not Available			

Figure 3 - RT-2111 Exploded View

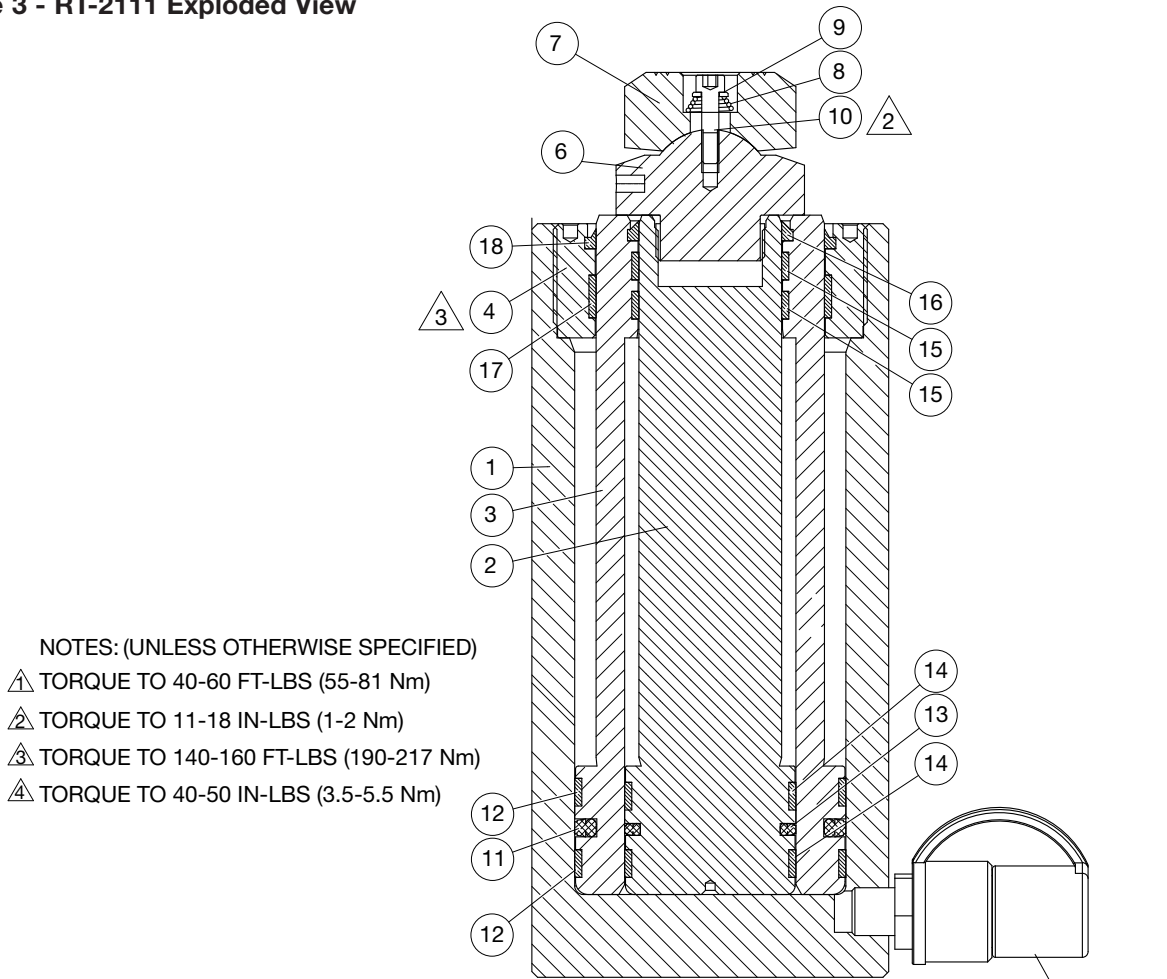

- NOTES: (UNLESS OTHERWISE SPECIFIED)
- ▲ TORQUE TO 40-60 FT-LBS (55-81 Nm)
 - ▲ TORQUE TO 11-18 IN-LBS (1-2 Nm)
 - ▲ TORQUE TO 140-160 FT-LBS (190-217 Nm)
 - ▲ TORQUE TO 40-50 IN-LBS (3.5-5.5 Nm)

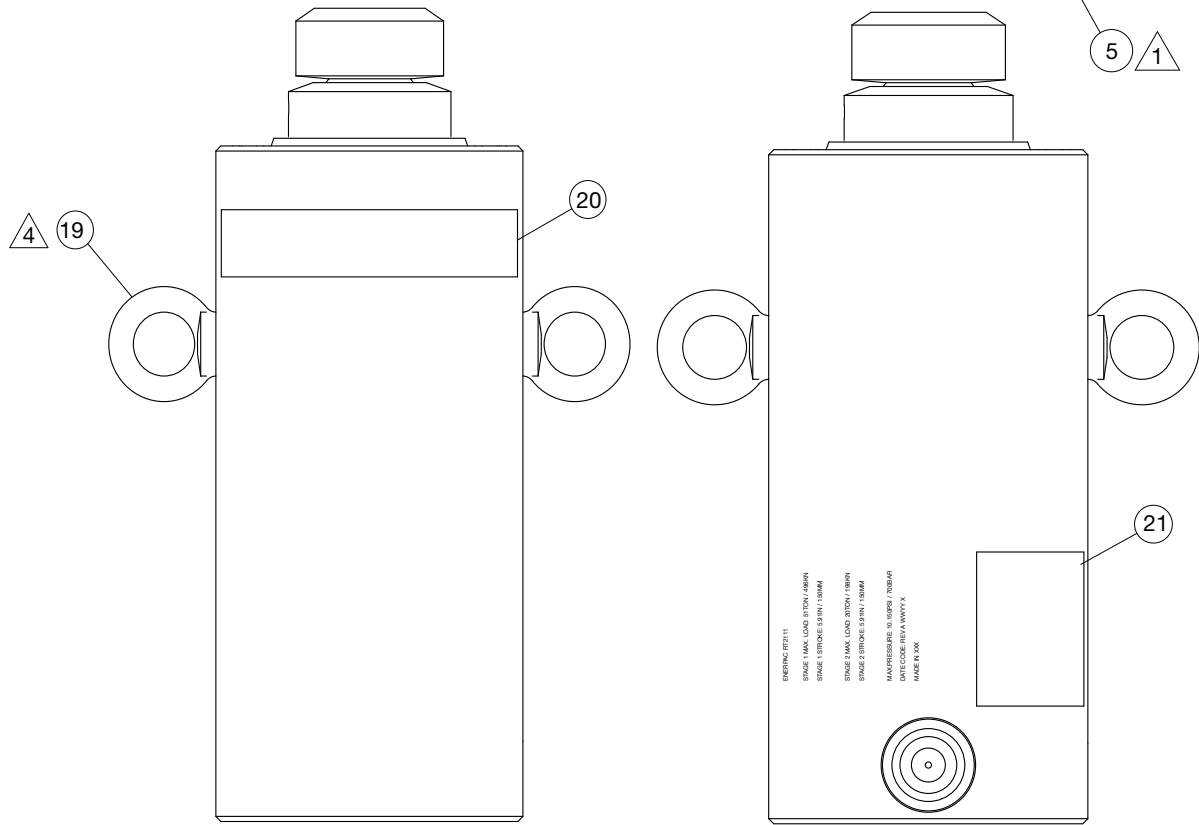

Parts List for Figure 3			
Item Number	Part Number	Description	Qty.
1	N/A	Base RT-2111	1
2	N/A	Plunger 1 RT-2111	1
3	N/A	Plunger 2 RT-2111	1
4	B170020044-30	Stop Ring RT-2111	1
5	CR400	Female Coupler	1
6	B170020045-30	Tilting Saddle Base RT-2111	1
7	B170020045-31	Saddle RT-2111	1
8	B170020210-20	Spring Cone 18.5 O.D. x 25mm	1
9	CAE1060108-1A	Flat Washer M6	1
10	CCA623028-1A	Screw SHC, M6 x 1.0 - 20mm LG	1
11	★	Piston Seal 95 x 79.5 x 6.3	1
12	★	Bearing Piston 95 x 90 x 7.9	2
13	★	Piston Seal 60 x 49 x 4.2	1
14	★	Bearing 60 x 55 x 9.7	2
15	★	Bearing Rod 50 x 55 x 9.7	2
16	★	Scraper 50 x 58 x 4	1
17	★	Bearing Rod 80 x 85 x 15	1
18	★	Scraper 80 x 88 x 4	1
19	DB8099667	Eyebolt, Rotating, M6	2
20	★ G424026	Enerpac Decal 5.19 x 1.00	1
21	★ DA5625026	Warning Decal 2.19 x 3.18	1
22	★	Coupler O-Ring (Not Shown)	1
★	RT2111K	Service Kit	
N/A - Not Available			

Figure 4 - RT-2119 Exploded View

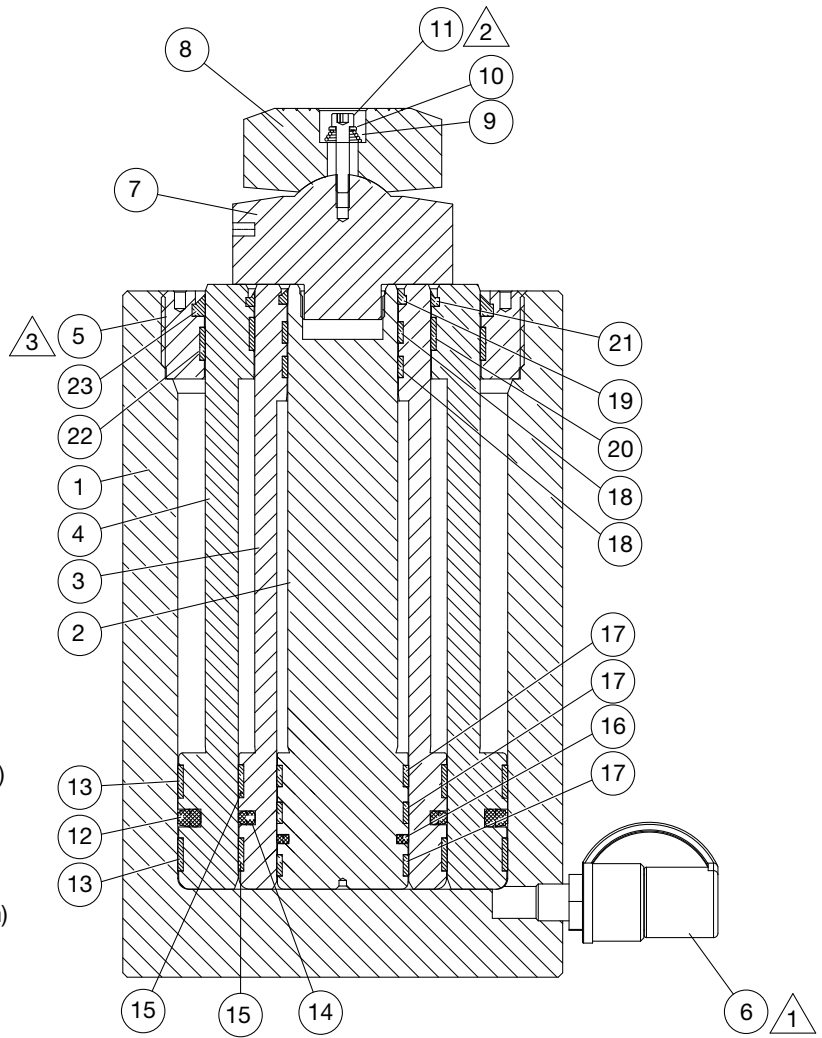

NOTES: (UNLESS OTHERWISE SPECIFIED)

- 1 TORQUE TO 40-60 FT-LBS (55-81 Nm)
- 2 TORQUE TO 11-18 IN-LBS (1-2 Nm)
- 3 TORQUE TO 140-160 FT-LBS (190-217 Nm)
- 4 TORQUE TO 40-50 IN-LBS (3.5-5.5 Nm)

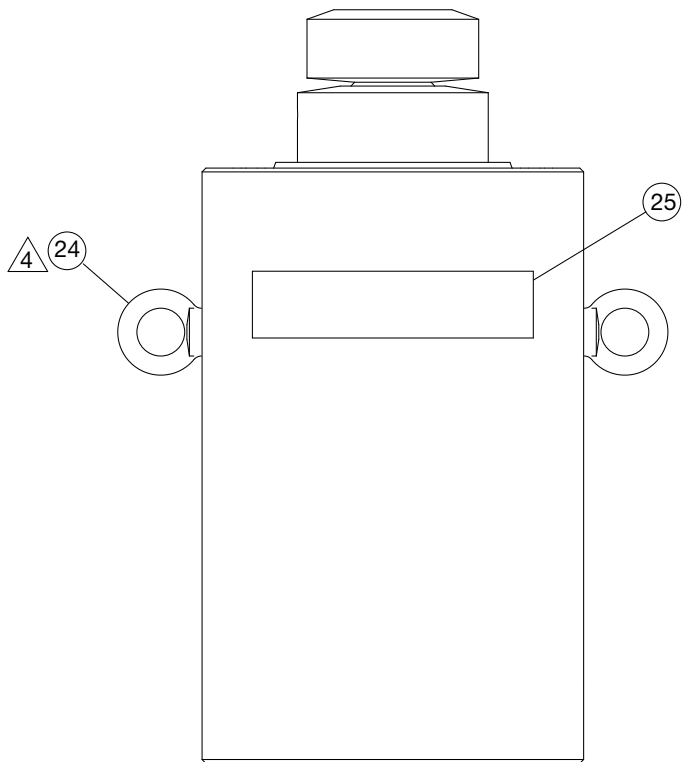
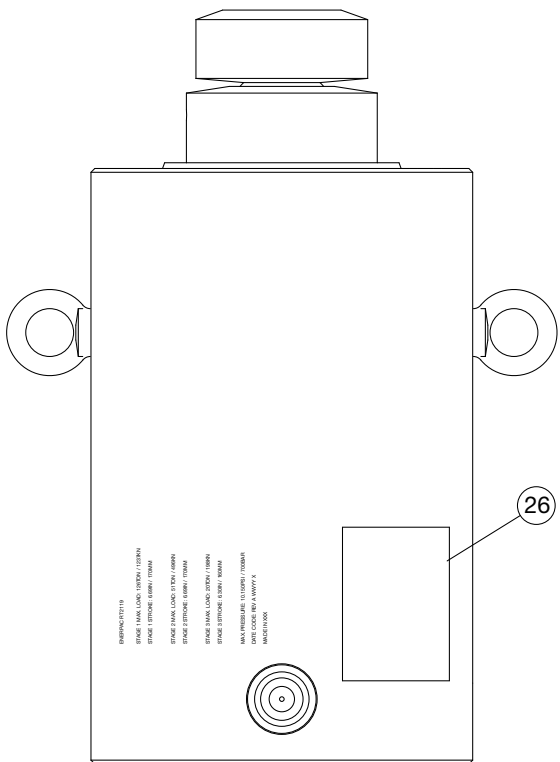

Parts List for Figure 4			
Item Number	Part Number	Description	Qty.
1	N/A	Base RT-2119	1
2	N/A	Plunger 1 RT-2119	1
3	N/A	Plunger 2 RT-2119	1
4	N/A	Plunger 3 RT-2119	1
5	B170020044-40	Stop Ring RT-2119	1
6	CR400	Female Coupler	1
7	B170020045-41	Tilting Saddle Base RT-2119	1
8	B170020045-40	Saddle RT-2119	1
9	B170020210-20	Spring Cone 18.5 O.D. x 25mm	1
10	CAE1060108-1A	Flat Washer, M6	1
11	CCA625028-1A	SHCS, M6 x 1.0 x 30	1
12	★	Piston Seal 150 x 129 x 8.1	1
13	★	Bearing Piston 150 x 145 x 15	2
14	★	Piston Seal 95 x 79.5 x 6.3	1
15	★	Bearing Piston 95 x 90 x 15	2
16	★	Piston Seal 60 x 49 x 4.2	1
17	★	Bearing 60 x 55 x 9.7	3
18	★	Bearing Rod 50 x 55 x 9.7	2
19	★	Scraper 50 x 58 x 4	1
20	★	Bearing Rod 80 x 85 x 15	1
21	★	Scraper 80 x 88 x 4	1
22	★	Bearing Rod 125 x 130 x 15	1
23	★	Scraper 125 x 137 x 4	1
24	DB8099667	Eyebolt, Rotating, M6	2
25	★ G425026	Enerpac Decal, 7.38 x 1.75	1
26	★ DA5625026	Warning Decal, 2.19 x 3.18	1
27	★	Coupler O-Ring (Not Shown)	1
★	RT2119K	Service Kit	
N/A - Not Available			

Figure 5 - RT-3311 Exploded View

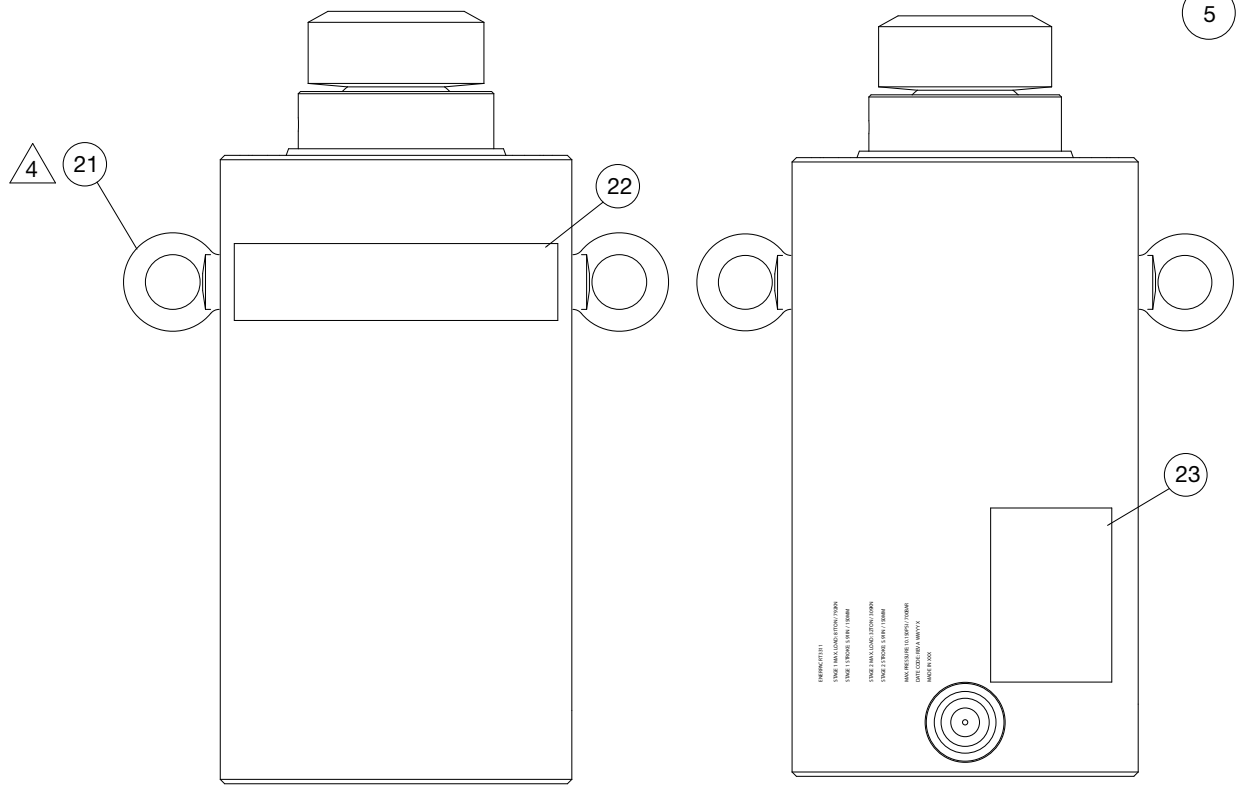
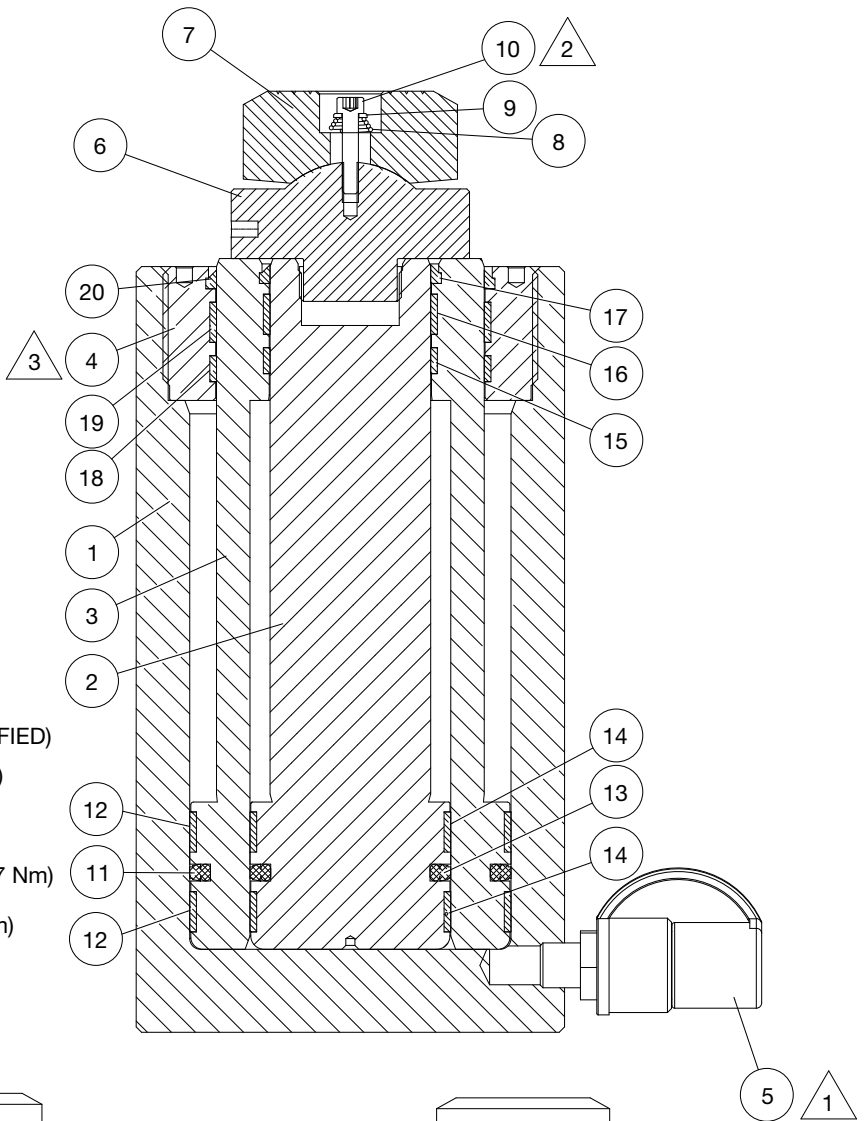

Parts List for Figure 5			
Item Number	Part Number	Description	Qty.
1	N/A	Base RT-3311	1
2	N/A	Plunger 1 RT-3311	1
3	N/A	Plunger 2 RT-3311	1
4	B170020044-50	Stop Ring RT-3311	1
5	CR400	Female Coupler	1
6	B170020045-50	Tilting Saddle Base RT-3311	1
7	B170020045-51	Saddle RT-3311	1
8	B170020210-20	Spring Cone 18.5 O.D. x 25mm	1
9	CAE1060108-1A	Flat Washer M6	1
10	CCA625028-1A	SHCS, M6 x 1.0 x 30	1
11	★	Piston Seal 120 x 104.5 x 6.3	1
12	★	Bearing Piston 120 x 115 x 15	2
13	★	Piston Seal 75 x 59.5 x 6.3	1
14	★	Bearing Piston 75 x 70 x 15	2
15	★	Bearing Rod 60 x 65 x 9.7	1
16	★	Bearing 60 x 65 x 15	1
17	★	Scraper 60 x 68 x 4	1
18	★	Bearing Rod 100 x 105 x 15	1
19	★	Bearing Rod 100 x 105 x 9.7	1
20	★	Scraper 100 x 108 x 4	1
21	DB8099667	Eyebolt, Rotating, M6	2
22	★ G425026	Enerpac Decal 7.38 x 1.75	1
23	★ DA5625026	Warning Decal 2.19 x 3.18	1
24	★	Coupler O-Ring (Not Shown)	1
★	RT3311K	Service Kit	
N/A - Not Available			

Figure 6 - RT-3323 Exploded View

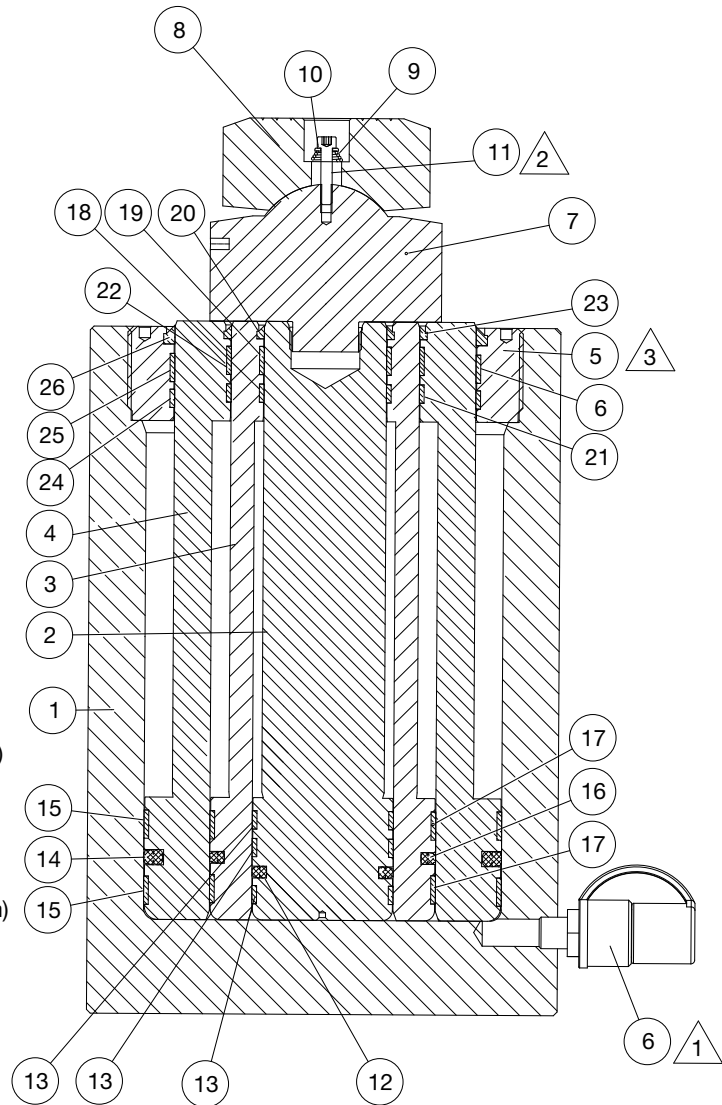

NOTES: (UNLESS OTHERWISE SPECIFIED)

- ▲ 1 TORQUE TO 40-60 FT-LBS (55-81 Nm)
- ▲ 2 TORQUE TO 11-18 IN-LBS (1-2 Nm)
- ▲ 3 TORQUE TO 140-160 FT-LBS (190-217 Nm)
- ▲ 4 TORQUE TO 80-100 IN-LBS (9-11 Nm)

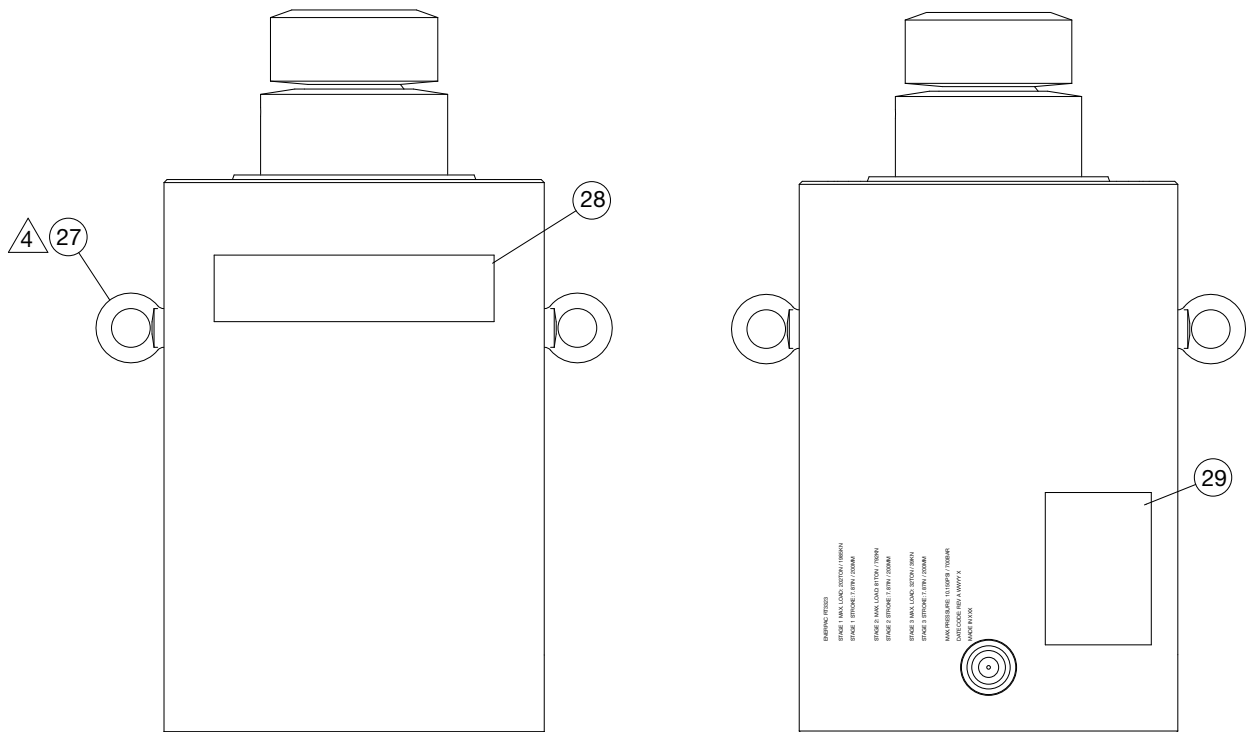

Parts List for Figure 6			
Item Number	Part Number	Description	Qty.
1	N/A	Base RT-3323	1
2	N/A	Plunger 1 RT-3323	1
3	N/A	Plunger 2 RT-3323	1
4	N/A	Plunger 3 RT-3323	1
5	B170020044-60	Stop Ring RT-3323	1
6	CR400	Female Coupler	1
7	B170020045-60	Tilting Saddle Base RT-3323	1
8	B170020045-60	Saddle RT-3323	1
9	B170020210-20	Spring Cone 18.5 O.D. x 25mm	1
10	CAE1060108-1A	Flat Washer, M6	1
11	CCA625028-1A	SHCS, M6 x 1.0 x 30	1
12	★	Piston Seal 75 x 59.5 x 6.3	1
13	★	Bearing Piston 75 x 70 x 9.7	3
14	★	Piston Seal 190 x 169 x 8.1	1
15	★	Bearing Piston 190 x 185 x 15	2
16	★	Piston Seal 120 x 104.5 x 6.3	1
17	★	Bearing Piston 120 x 115 x 15	2
18	★	Bearing Rod 65 x 70 x 9.7	1
19	★	Bearing Rod 65 x 70 x 15	1
20	★	Scraper 65 x 73 x 4	1
21	★	Bearing Rod 100 x 105 x 9.7	1
22	★	Bearing Rod 100 x 105 x 15	1
23	★	Scraper 100 x 108 x 4	1
24	★	Bearing Rod 160 x 165 x 9.7	1
25	★	Bearing Rod 160 x 165 x 15	1
26	★	Scraper 160 x 172 x 5.5	1
27	DB8099667	Adjustable Eyebolt, M8	2
28	★ G425026	Enerpac Decal, 9.38 x 2.00	1
29	★ DA5625026	Warning Decal, 2.19 x 3.18	1
30	★	Coupler O-Ring (Not Shown)	1
★	RT3323K	Service Kit	
N/A - Not Available			

NOTES:

ENERPAC 

www.enerpac.com