



Touchboards

205 Westwood Ave, Long Branch, NJ 07740
Phone: 866-94 BOARDS (26273) / (732)-222-1511
Fax: (732)-222-7088 | E-mail: sales@touchboards.com



R **Richelieu**
ERGO



computer ergonomics
&
office accessories

CONTENTS

TABLE LEGS	3
BUDGET COMBOS	13
CONVENIENCE COMBOS	14
KEYBOARD TRAYS	16
KEYBOARD ARMS	18
SIT/STAND WORKSTATIONS	21
MONITOR SUPPORTS	22
LAPTOPS AND IPADS HOLDERS	35
RETRO KITS.....	37
HEALTHCARE PRODUCTS	38
CPU HOLDERS.....	42
LIGHTING	44
POWER MANAGEMENT	46
WIRE MANAGEMENT AND GROMMETS	48
ACCESSORIES	50
DRAWERS.....	51
TRAYS AND DOCUMENT SUPPORTS.....	52
ABOVE DESK STORAGE SYSTEM	53
WHITEBOARDS AND TACKBOARDS.....	54

UNITE ADJUSTABLE LEGS

PRECISE

Our handset provides 4 programmable positions along with an LED readout of desk height. No more searching for your favourite positions.

SPEEDY

At 1.5 inches per second, our lifting speed swiftly moves you from one position to another.

SMART

The sophisticated programming in our control box creates the quality of movement you'd expect from a high-end product.

- Software ensures soft start/stop
- Hall sensor measures speed and alignment
- Temperature sensors protect circuitry and motors to assure long life

STRONG

We only use powder-coated steel construction and powerful DC motors with high lifting capacities.

UNITE 2 LEG ADJUSTABLE LEGS

- Full height range: seated keyboard to full standing (23.4"-49")
- 330 lb lifting capacity
- 1.5 inches/second
- LED programmable handset
- 2 Powerful dc motors.
- Adjustable leveling legs

- 500782100** Gray
- 50078290** Black

One Touch Precision



Smart Circuitry



UNITE 3 LEG ADJUSTABLE LEGS

- Full height range: seated keyboard to full standing (23.4"-49")
- 465 lb lifting capacity
- 1.5 inches/second
- LED programmable handset
- 3 Powerful dc motors.
- Adjustable leveling legs

- 500783100** Gray
- 50078390** Black

One Touch Precision



Smart Circuitry

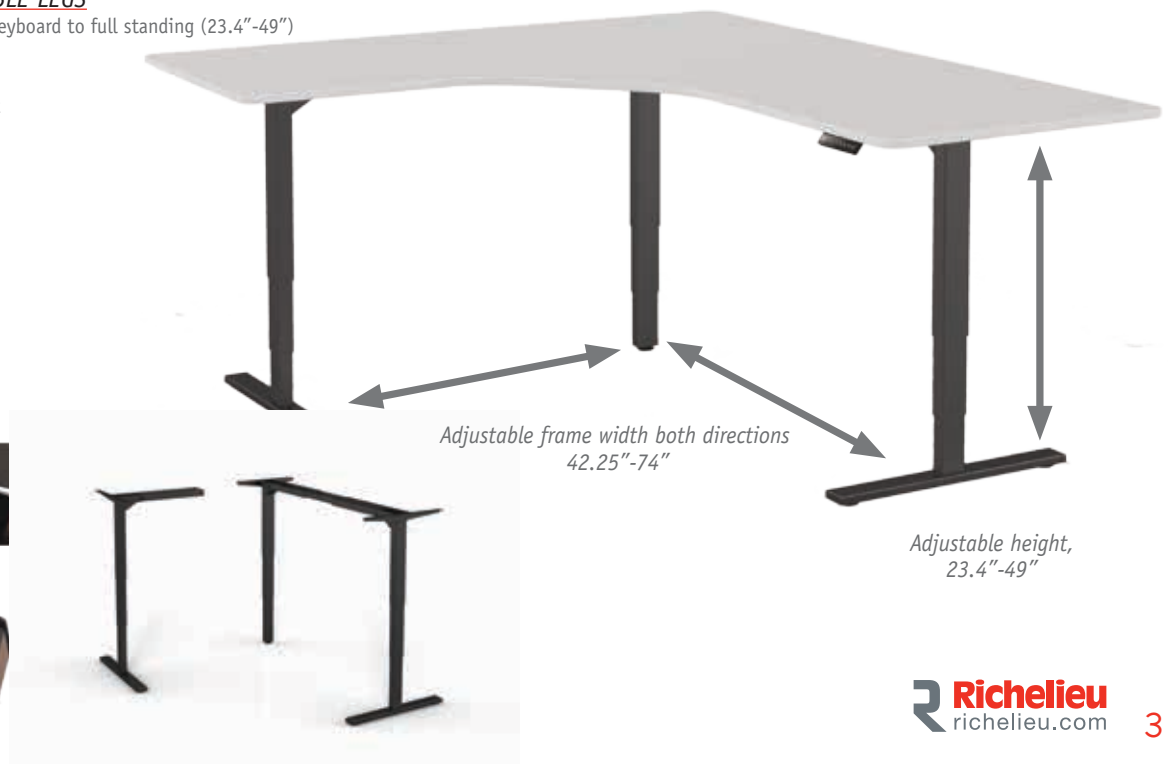

TABLE LEGS

ACES ADJUSTABLE BASES

SIMPLE

Includes basic UP/DOWN control switch.

STRONG

We only use powder-coated steel construction and powerful DC motors with high lifting capacities.

SMART

The sophisticated programming in our control box creates the quality of movement you'd expect from a high-end product.

- Software ensures soft start/stop
- Hall sensor measures speed and alignment
- Temperature sensors protect circuitry and motors to assure long life



ACES 2 LEG ADJUSTABLE LEGS

- Round Table legs
- Full height range: seated keyboard to full standing (23.4"-50")
- 330 lb lifting capacity
- .8 inches/second
- 2 Powerful dc motors.
- Adjustable leveling legs

50078430 White

50078490 Black

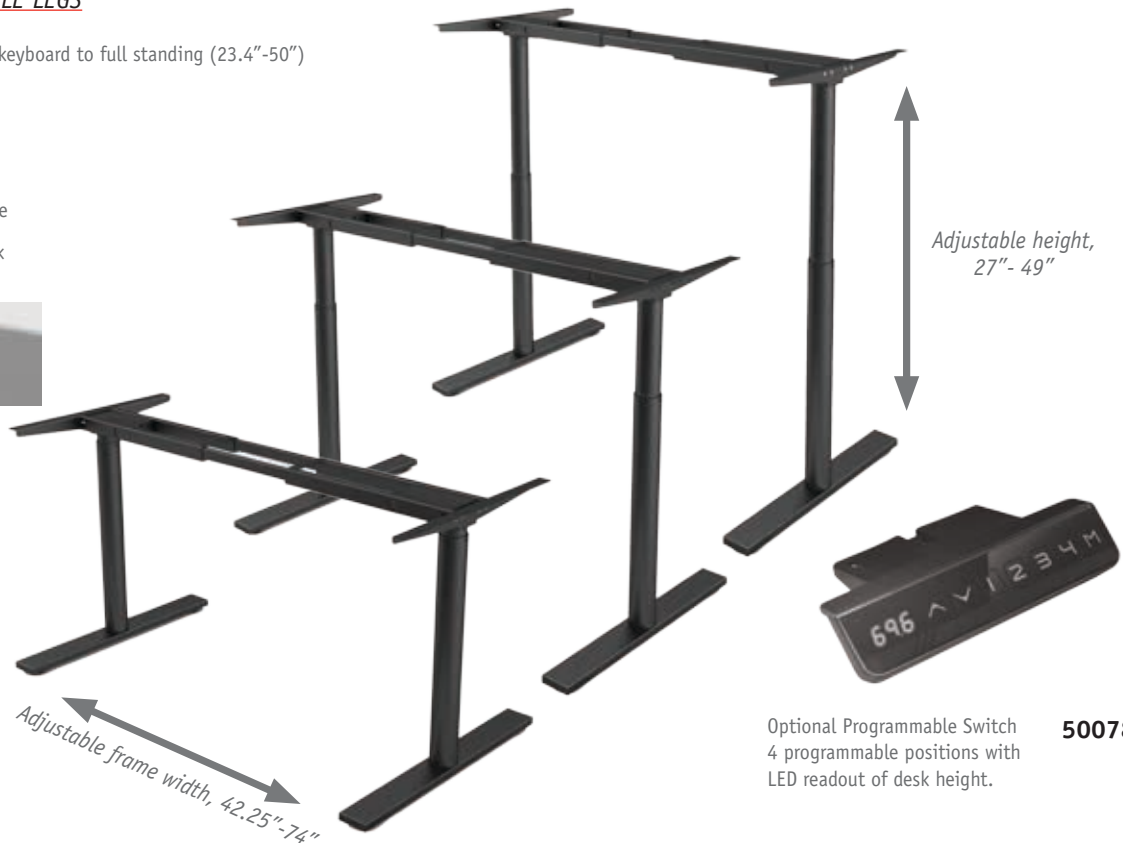

Optional Programmable Switch
4 programmable positions with
LED readout of desk height.

50078590

BALANCE ADJUSTABLE BASES

BALANCE PROVIDES DISTINCT ADVANTAGES OVER ELECTRIC. NO POWER CONSUMPTION SAVES ENERGY! FASTER ADJUSTMENT, JUST SECONDS TOP TO BOTTOM AND BACK AGAIN! NO CORDS TO PLUG IN! NO COMPLICATED ELECTRONIC CONTROLS!

- Unique synchronization enables adjustment even with uneven loads
- Precision tube and rollers for the smoothest adjustment
- Easy control of speed with release mechanism
- Eliminates the possibility of accidental release by the design of the release handle

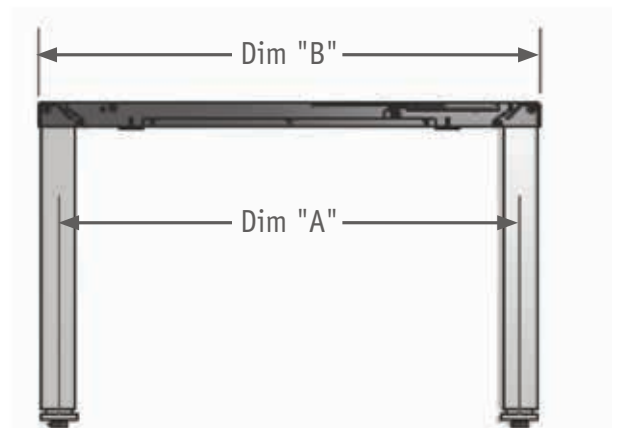

	Capacity In Pounds	Dim "A"	Dim "B"
5007881XXX	42 to 82	37.16"	40.40"
5007882XXX	53 to 93	52.91"	56.14"

Replace XXX with color code White 30, Black 90, Silver 100

TABLE LEGS

HIKER HEIGHT ADJUSTABLE BASES

CREATE AN ELECTRIC HEIGHT ADJUSTABLE TABLE TO MEET YOUR REQUIREMENTS WITH THE HIKER PROGRAM

BUILT-IN AUTO STOP IN BOTH UP AND DOWN DIRECTIONS, MEETS OR EXCEEDS BOTH ANSI & BIFMA STANDARDS. LIGHT WEIGHT ALL ALUMINUM FRAMES. ELECTRICALLY POWERED LEGS SIMPLE ASSEMBLY. SCALABLE DESIGN PROVIDES AFFORDABLE AND CUSTOMIZED SOLUTIONS WITH STANDARD COMPONENTS. ADVANCED SAFETY AND OPERATION FEATURES INCLUDED AS STANDARD.



HIKER 2 LEG ELECTRIC ADJUSTABLE

Legs only (Requires 5007205100 or 5007206100 Modesty Rail)

- Clear Anodized frame finish.
- 16" height adjustment range – 25.5" to 41.5" below surface.
- Up/down switch.
- Includes 2 Leg controller package.

5007202100



HIKER 3 LEG ELECTRIC ADJUSTABLE

Legs only (Requires 5007205100 or 5007206100 Modesty Rail)

- Clear Anodized frame finish.
- 16" height adjustment range – 25.5" to 41.5" below surface.
- Up/down switch.
- Includes 3 Leg controller package.
- Includes 2 mending plates.

5007203100

CONTROLLER PACKAGES

2 Leg Controller	500703290
3 Leg Controller	500703390
4 Leg Controller	500703490



TABLE LEGS



SINGLE LEG MODULE COMPONENT

- Requires Controller Package to match total leg quantity
Incompatible with Modesty Rails.

500701100

27 1/4" FIXED HEIGHT LEGS

- 24" to maximum 30" deep surfaces
- A perfect match to the rest of the Hiker Program
- Sold in pairs

500704100

Custom heights available through Special Order.



HIKER 2 LEG TOP CRANK ADJUSTABLE LEGS ONLY

(Requires 5007207100 or 5007208100 Modesty Rail)

- Clear Anodized frame finish.
- 14" height adjustment range – 23.5" to 37.5" below surface.
- Removable top crank handle.

5007204100



ELECTRIC LEG MODESTY RAILS

Available in two widths

Short Modesty Rail 23"-39"

Recommended for work surfaces from 36" to 54" wide

5007205100

Long Modesty Rail 43"-73"

Recommended for work surfaces from 60" to 84" wide

5007206100

CRANK MODESTY RAILS

- Available in two widths
- Long Rail includes anti-deflection tube

Short Modesty Rail 23"-39"

Recommended for work surfaces from 30" to 48" wide

5007207100

Long Modesty Rail 43"-73"

Recommended for work surfaces from 54" to 84" wide

5007208100

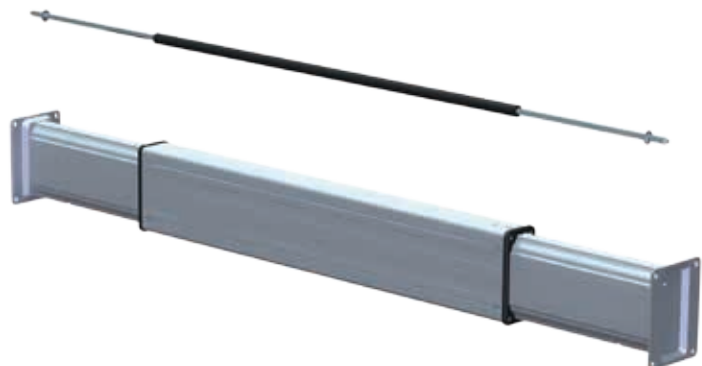

FRONT CRANK CONVERSION KIT

- Converts Top Crank to front crank

500720890



TABLE LEGS

HIKER GABLE MOUNT ADJUSTABLE LEGS

HIKER STYLE – CRANK ADJUSTABLE – 2 LEG SOLUTION.

- Adjustment is with a retractable telescoping front crank – in line with leg. (Left or right handed).
- Height range is 14" – collapsed height is 21.75"
- Dynamic lifting capacity is 150 lb
- Gable brackets.
- Connector shaft with 14" width adjustment.
- Front crank assembly outside to outside of legs including gable mounts may be adjusted from 30" to 44" wide.
- Minimum surface depth is 24" - Maximum surface depth is 30".
- All legs finished clear anodized – top and bottom plates are powder coated black.

500707100



HIKER STYLE – CRANK ADJUSTABLE – 3 LEG SOLUTION.

- Adjustment is with a retractable telescoping front crank – in line with leg. (Outer left or right handed – corner leg not possible).
- Height range is 14" – collapsed height is 21.75"
- Dynamic lifting capacity is 150 lb
- Gable brackets.
- Connector shaft with 14" width adjustment.
- Front crank assembly outside to outside of legs including gable mounts may be adjusted from 30" to 44" wide.
- Minimum surface depth is 24" - Maximum surface depth is 30".
- All legs finished clear anodized – top and bottom plates are powder coated black.

500708100



MOTOR RETROFIT KIT FOR CRANK ADJUSTABLE LEGS .

- Mounts in-line with connector shaft
- This solution is intended to replace the front crank method of height adjustment. It does not increase the weight capacity or allow for a different adjustment range.

500703590



ASCENT SERIES ELECTRIC ADJUSTABLE BASES

A PEDESTAL STYLE ELECTRIC HEIGHT ADJUSTABLE BASE THAT CAN HANDLE OVERSIZED CORNER APPLICATIONS.

- Height adjustment from 680mm (28.6") to 1200mm (48")
- Can be used with top sizes from 120cm (47.25") to 180cm (70.86") wide and 50cm (19.69") to 100 cm (39.37") deep
- 100w AC Power Transformer
- 1.8 meter (70.5") power cord
- Max load of 80kg (176 lb)
- Ships knocked down in 2 boxes, some assembly is required

Color	Pedestal	Curved Base	Angled Base
Silver	500752100	500762100	500772100
Black	50075290	N/A	50077290



TWIN-RISE SERIES ELECTRIC ADJUSTABLE BASES

AN ELECTRIC HEIGHT ADJUSTABLE BASE THAT IS AN ECONOMICAL SOLUTION FOR RETURNS, TRAINING TABLES OR SMALL WORKSTATIONS, THE TWIN-LIFT IS A MODERN LIGHT DESIGN WITH A REASONABLE PRICE.

- Easy to move with rear built in casters
 - Height adjustment from 680mm (28.6") to 1200mm (48")
 - Handles top sizes from 50cm (19.69") to 100 cm (39.37") deep
 - 100w AC Power Transformer
 - 1.8 meter (70.5") power cord
 - Max load of 80kg (176 lb)
 - Ships knocked down in 2 boxes, some assembly is required
- *Top not included*

	Set of 2 Legs	Long Modesty Rail 61-7/16"	Short Modesty Rail 37-13/16"
Top Size	-	160cm (63") to 180cm (70.86") wide	100cm (39.37") to 120cm (47.25") wide
Silver	500753100	500763100	500773100



TABLE LEGS

ARISE SERIES ELECTRIC ADJUSTABLE BASES

ELECTRIC ACTUATOR ADJUSTABLE HEIGHT TABLE BASES

- Our most economical sit/stand table.
- A pedestal style electric height adjustable base that is perfect for corner applications or training tables.
- With the locking casters on the rear of the base moving the table around when required is easy, or lock them down when used in a permanent application.
- With 520mm (20.5") of height adjustment from 660mm (26") to 1180mm (46.5")
- Can be used with top sizes from 95cm (37.5") – 117cm (49") wide X 80cm (31.5")-100cm (39.37") deep

Black **50075190**
Silver **500751100**

**Top not included*



Includes pedestal leg, base with casters, table mount braces, power transformer, power cord, and rocker switch



ARISE II

- 1.5 inches/second
- Soft touch up/down buttons
- Powerful dc motor capable of smoothing lifting 165 lb
- Adjustable leveling legs

500745490



Soft touch up/down buttons



*Adjustable height,
26.4"-44"*

External Power Supply



TABLE LEGS



29.0	Walnut
28.0	Cherry
21.0	Maple
25.0	Oak
900	Mat Black
10	Aluminum
170	St. steel
140	Chrome
30	White
90	Black



No.	Finish	Dia.	Height
615710-	30, 90, 140, 170, 175	60 mm	710 - 740 mm
615870-	30, 90, 140, 175	60 mm	870 - 900 mm
620710-	10, 30, 90, 175, 900	80 mm	710 - 740 mm

OPTION TABLE LEG COVER

No.	Finish	Dia.	Height
D 6600010-	170, 900	60 mm	140 mm
E 660004-	90	70 mm	140 mm



FURNITURE TABLE LEG

No.	Finish	Dia.	Height
550100-	10, 140, 170, 900	50 mm	100 - 130 mm
550150-	10, 140, 170	50 mm	150 - 180 mm
555100-	900, 170	49 mm	100 - 150 mm
555150-	900, 170	49 mm	100 - 150 mm



No.	Finish	Dia.	Height
A 660710-	106, 140, 170, 900	60 mm	710 - 810 mm
B 660001-	90, Caster	50 mm	72 mm
C 660002-	90 Caster	70 mm	120 mm
D 660650-	106, 140, 170, 900	60 mm	650 - 750 mm

Zoom - legs 100 mm high adjustment

ALUMINA GLASS TABLE LEG

- 60 mm dia x 720 mm + 30 mm adjustment
- Ridged satin aluminum finish

61271010



- Stainless steel cap
- Glue to table with UV glue (D030143) and screw on leg

81200170



TAPERED TABLE LEG

- Chrome
- 710 mm high
- 10 mm adjustment

407710170



CLICK - FOLDING TABLE LEG

- 50 mm dia x 710 mm + 30 mm adjustment

65671010 Aluminum

65671090 Black



TABLE LEGS

QUADRA - SQUARE LEG



- 60 mm square x 700 mm + 10 mm adjustment
 - Ridged aluminum finish
- 64671010**



Flush mounting



OVAL

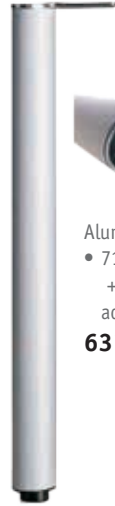

- Aluminum
- 710 mm high + 10 mm adjustment
- 63771010**

TEARDROP

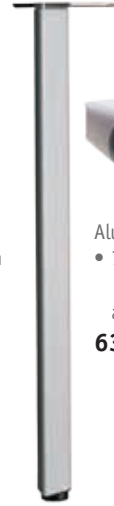

- Aluminum
- 710 mm high + 10 mm adjustment
- 63271010**

TRIANGULAR



- Aluminum
- 710 mm high + 10 mm adjustment
- 63371010**

DESIGN TABLE LEGS

METAL/WOOD LEG SILVER/BEACH

- Metal and wood
 - Leg ready to finish
 - H = 710 mm
 - + 10 mm adjustment
- 40410622**



ELLIPTICAL TABLE LEG

- Elliptic leg: 60 mm x 30 mm
 - H = 710 mm
 - Silver finish
- 192710106**



- Round arquer leg: 50 mm diam.
 - H = 705 mm
 - Silver finish
 - + 20 mm adjustment
- 650705106**



- Round arquer leg: 50 mm diam.
 - H = 700 mm
 - Silver finish
 - + 20 mm adjustment
- 612705106**



BUDGET COMBOS

Our new Budget Combo's are designed to maintain proper ergonomics when budgets get tight. Featuring our new Budget arm 50074311790. This arm features the same Lift-N-Lock™ technology as our best selling momentum arm. The Budget arm features 6.4" of height adjustment ,15° negative tilt and 10° positive tilt through a friction adjustment knob, with 11.9" of travel on a 17" base frame.

We have paired the budget arm with our best selling trays to provide you with the best quality product in a budget price. When budgets get tight and you think there is no room for keyboard arms think about the Budget Combo's from Richelieu.



5007431BC3

- 27" x 10" phenolic keyboard tray
- Accommodates both keyboard and mouse
- Full-length removable palm rest
- Mouse pad with corral to keep mouse on tray



50074311790

Arm only

5007431BC1

- 20 x 9½" phenolic keyboard tray
- Full-length removable palm rest
- 8" dia. Mouse pad with corral to keep mouse on tray



5007431BC4

- 26⅝" x 10⅞" metal/ABS
- Easy slide out mouse tray with horizontal adjustment
- 100% recyclable materials
- Built in Wire management and document support
- Padded removable palm rest

CONVENIENCE COMBOS

CONVENIENCE COMBOS

THESE CONVENIENCE COMBOS CONTAIN OUR MOST POPULAR TRAYS WITH OUR #1 SELLING ARM, PACKED IN ONE BOX WITH A SINGLE PART NUMBER MAKES FOR EASY ORDERING AND SHIPPING

The Ultra Momentum articulating keyboard arm incorporates dial knob technology for easy tilt adjustment from -20 degree* to +10 degrees, allowing for optimum comfort to a variety of users. The Ultra Momentum arm also features Lift-N-Lock™ technology for effortless height adjustment from +2 3/8" to -6 1/2", from top of track, ensuring the easiest, most comfortable and convenient arm for use in the office environment. In addition it now features height and tilt indicators to compliment the ease of use. The Ultra Momentum is available in a 5.5" neck with a Teflon Glide Track. (*Height measured from top of track, positive tilt locked out at factory, user may override with removal of lock-out clip)

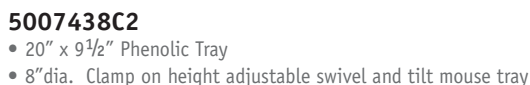
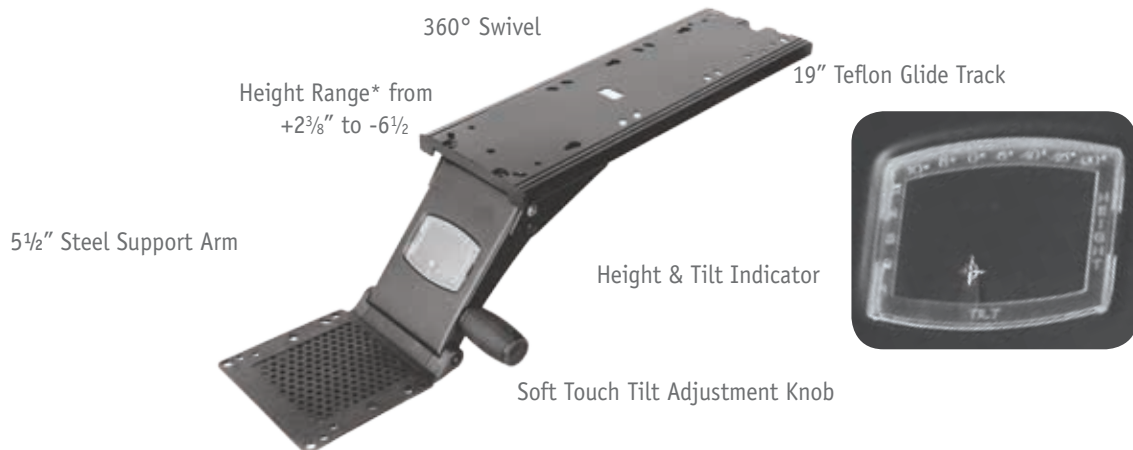

CONVENIENCE COMBOS

5007438C3

- 27¹/₄" x 10" Phenolic Tray
- Accommodates both keyboard & mouse



5007438C4

- 26⁵/₈" x 10⁷/₈" Steel/ABS
 - Easy slide out mouse tray with horizontal adjustment"
 - 100% Recyclable Materials
- *Shown with mouse tray extended.*

5007438C5

- 20" x 9¹/₂" HDPE Tray
- 8" dia. Clamp on height adjustable swivel and tilt mouse tray
- 100% Recyclable Materials



5007438C6

- 27¹/₄" x 10" HDPE Tray
- Accommodates both keyboard & mouse
- 100% Recyclable Materials



KEYBOARD TRAYS

GREEN SERIES



DYNAMITE

- 26⁵/₈" x 10⁷/₈" metal/ABS
- Easy slide out mouse tray with horizontal adjustment
- 100% Recyclable Materials
- Built in Wire management and document support
- Padded palm rest

50420890

**Shown with mouse tray extended.*

PHENOLIC SERIES

504200 SERIES KEYBOARD TRAYS

- 20" x 10¹/₂" phenolic keyboard tray
- 1/4" thick
- Mouse pad with corral to prevent mouse run off
- Foam and Gel palm rest options



	Foam Palm Rest	Gel Palm Rest
No mouse tray	504202100	504202G100
Swivel mouse tray, non-tilting left or right mount	504204100	504204G100
Clamp on height adjustable swivel and tilt mouse tray	504205100	504205G100

504300 SERIES KEYBOARD TRAYS

- Phenolic tray for Microsoft Natural Keyboard™
- 22" x 11¹/₂" Dimension
- 1/4" thick
- Mouse pad with corral to prevent mouse run off



Swivel mouse tray, non-tilting left or right mount	504304100
Clamp on height adjustable swivel and tilt mouse tray	504305100

504400 CORNER SERIES KEYBOARD TRAYS

- 20" x 13¹/₂" phenolic keyboard tray
- 1/4" thick
- Palm rest
- Mouse pad with corral to prevent mouse run off



	Foam Palm Rest	Gel Palm Rest
No mouse tray	504402100	504402G100
Swivel mouse tray, non-tilting, left or right mount	504404100	504404G100
Clamp on height adjustable swivel and tilt mouse tray	504405100	504405G100

PHENOLIC MOUSE TRAYS

- For use with Phenolic Series Keyboards



Swivel mouse tray, non-tilting, left or right mount
504104100



Clamp on height adjustable swivel and tilt mouse tray
504105100

27" PHENOLIC SERIES

- 27" x 10" phenolic keyboard tray
- 1/4" thick
- Accommodates both keyboard & mouse
- Full length palm rest
- Mouse pad with corral to prevent run off
- Can be used with all arms

Foam Palm Rest

5004227100

Gel Palm Rest

5004227G100



CLASSIC SERIES

- 27" x 10 1/2" vinyl wrapped keyboard tray
- Accommodates both keyboard and mouse
- Full length palm rest
- Perimeter lip prevents mouse run off
- Can be used with all arms or keyboard slides

50080190



BASIC SERIES

- 3 widths available
- 11" Deep Black Textured MDF keyboard tray
- Can be used with all arms or keyboard slides

Tray Width

23" **1467590**

27" **1462790**

30" **141090**



KEYBOARD ARMS

ULTRA MOMENTUM SERIES

THE ONLY ARM IN ITS CLASS THAT FULLY COMPLIES TO
ANSI/HFES, 100-2007 STANDARDS



50074382190

- Height and tilt indicator
- Lift-N-Lock™ spring-assisted height adjustment
- Storable on a 19" Teflon glide
- Height adjustment from +2³/₈" to -6¹/₂"
- -20° tilt adjustment from neutral position with removal of lock-out clip
- Optional +10° tilt
- 360° swivel

50074381790

17" low profile base frame

50075382190

19" low ball bearing base frame with positive lock out

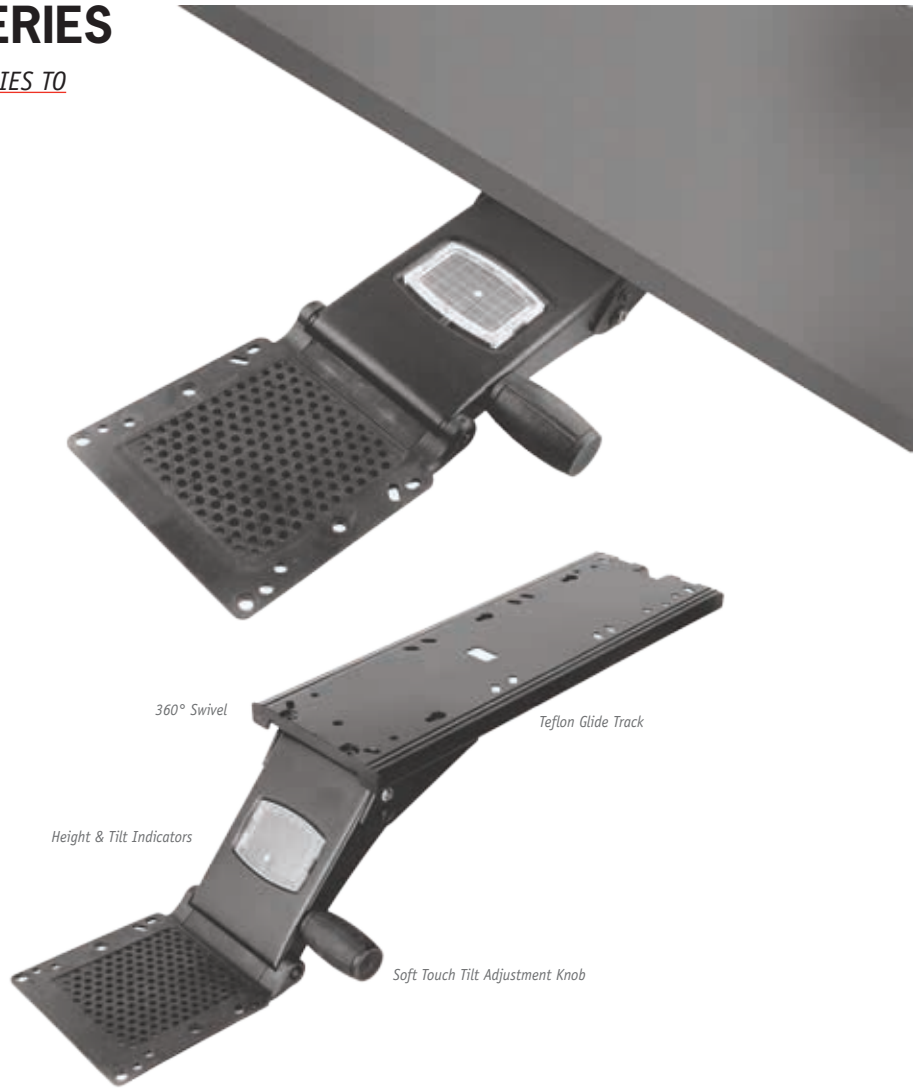

SIT/STAND SERIES

500745890

- Height range: 8¹/₄" above track and 5⁷/₈" below track,
- Reduced neck length allows the user to be closer to the desk
- Allows for full storage with most keyboard trays on a 21³/₄" track
- Superior lock-up, increased stability and improved accuracy of tilt position
- Dial tilt gauge shows the angle of the tray from -15° to +10°
- Sit-Stand arms incorporate height gauge to mark user's best ergonomic keyboarding position
- With 360° swivel user can move keyboard freely from side to side

500755890

21.75" low profile ball bearing base frame



BASIC SERIES

500573390

- Spring assisted height adjustment with tension knob
- Storable on 17" Teflon glide
- 25° tilt adjustment
- 360° swivel

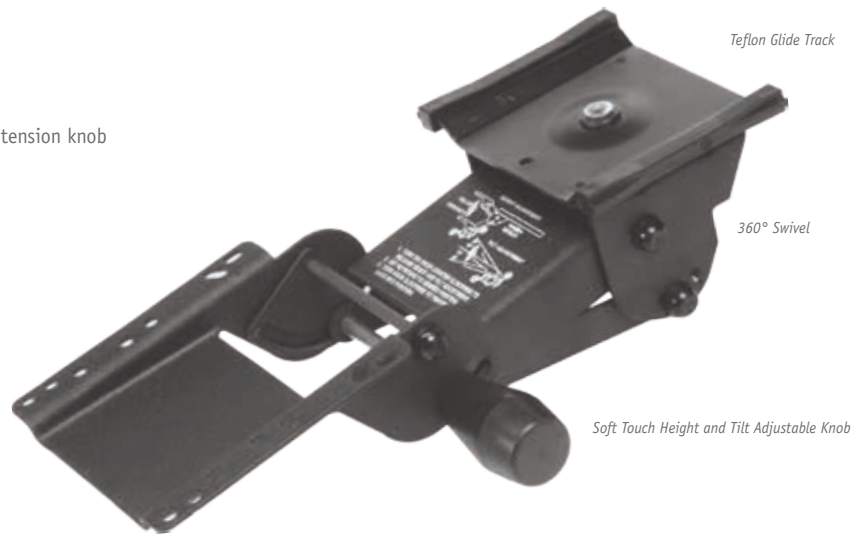

BUDGET KEYBOARD ARM, 17" TRACK

50074311790

- 6.4" of height adjustment
- 15° negative tilt and 10° positive
- 11.9" of travel on a 17" base frame.



ALL ARMS COME WITH TRACK FOR STORAGE



DUAL SWIVEL PLATE

500740090

- Allows for tray to be squared to the desk when mounted off center
- Can be added to any arm & tray

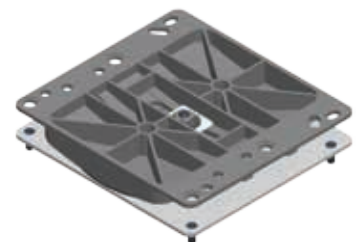

KEYBOARD ARMS

PULL OUT SERIES

ACCURIDE™ KEYBOARD DRAWER

530090

- This new keyboard system is designed to maximize your work space
- Adjustable keyboard platform offers three typing positions for maximum user comfort
- Innovative design
- Fully concealed, full extension slides
- Gel palm rest provides additional comfort
- Rear storage compartments
- Built-in cable management



22" KEYBOARD TRAY

- Complete with slides
- Slide out mouse tray, left or right
- Pencil storage
- All brackets included

50015390 Black

500153100 White



KEYBOARD SLIDES

35459016

- Bent down tabs for easy installation.
- Available in black
- 16" l with 14" extension

We have a wide variety Keyboard Slides available at www.richelieu.com



DUET ARM

- Stable, durable design
- Supports large widths and can be customized for work stations
- Slim arms (less than 3/4" each) for better knee clearance
- Height adjustable within 19" range (6 1/2" below work surface)
- Knob for independent tilt positioning
- Sit or stand applications
- Exceeds ANSI/BIFMA standards
- Accommodates secondary work surfaces
- Fixed table height application
- Heavy use typing



	Duet Short Arm 7" Above	Duet Long Arm 12.5" Above
20" width	50070902090	50070802090
23" width	50070902390	50070802390
27" width	50070902790	50070802790
31" width	50070903190	50070803190
39" width	50070903990	50070803990

THE TOPPER

SIT/STAND WORKSTATION

Energizing your body. Inspiring your mind. Instantly converts any desk into a sit stand workspace boosting health and productivity. The Topper seamlessly integrates into your workday for a boost in health and wellness.

- Take the work out of adjusting and replacing monitors. Simply attach, adjust, and remove all at the face of the beam.
- No need to slide monitors to remove.
- Designed to accommodate standing work without the distraction of unwanted movement.
- Large natural wood surface and convenient storage tray allow you to bring all necessities with you when you stand.
- Retrofit your existing desk into a healthy workspace with two easy mounting options: freestanding or desk clamp.
- Features a 17" range of vertical height adjustment and a locking cylinder to keep the workstation in place. No manual adjustment needed.
- Cable clips in the column and beam keep the cables organized and out of the way.
- The Topper is assembled in the USA using components created through a green manufacturing process.
- Stocked in white only



Single Monitor **500799130**



Dual Monitor **500799230**

TOPPER II

SIT/STAND WORKSTATION

- 20" of Infinite Height Adjust ability (2.5" Below Work-surface to 17.5" Above)
- Positive Lock with Push Button Release Height Adjustment
- 30° Keyboard Tilt Range ($\pm 15^\circ$)
- Includes 27" Tray with Palm Rest, Mouse pad, and Mouse Catcher
- Includes Tilting Document Holder
- Dual Monitor Adaptor Optional
- Non-marring Non-Skid Work-surface Protection
- Secure Rear Clamping to Work-surfaces from 3/4" to 1-1/2" Thick that are 23-1/2" to 30-1/2" Deep or Grommet Mount
- 75 - 100 mm VESA Bracket with Tilt is standard
- Cord Management included
- Proudly designed and manufactured in the USA



	Weight Rating	Grommet Mount	Clamp Mount
Single Monitor	5-15 lb	500799430	500799530
Dual Monitor	15-25 lb	500799630	500799730

MONITOR SUPPORTS

SINGLE PIVOT DESK MOUNTABLE LCD ARM



5006221106

- Single pivot point allows movement left to right
- 360° monitor rotation
- Up and down tilt
- 100 mm of spring assisted tool less height adjustment
- Complete with 75 mm and 100 mm VESA brackets
- Holds up to 17.6 lb, (8 kg)

DUAL PIVOT DESK MOUNTABLE LCD ARM



5006222106

- Two pivot points allows for left to right plus back and forth movement
- 360° monitor rotation
- Up and down tilt
- 100 mm of spring assisted tool less height adjustment
- Complete with 75 mm and 100 mm VESA brackets
- Holds up to 17.6 lb, (8 kg)



TRIPLE PIVOT DESK MOUNTABLE LCD ARM

5006223106

- Three pivot points allows for left to right plus back and forth movement (520 mm of reach is ideal for those deep corners)
- 360° monitor rotation
- Up and down tilt
- 100 mm of spring assisted tool less height adjustment
- Complete with 75 mm and 100 mm VESA brackets
- Holds up to 17.6 lb, (8 kg)



SINGLE ARM LCD FLAT PANEL DESK MOUNTS

- 11" sliding travel on the 12³/₈" post (amount of travel reduced based on the monitor being mounted)
- Includes grommet and clamp mount, clamping range of 0" – 3 1/2" grommet maximum surface thickness 2³/₄"
- 360° swivel monitor mount
- Handles monitors up to 20 lb (9 kg)
- Standard VESA Plate has 75mm and 100mm hole patterns as well as keyhole slots for easy monitor connection

SINGLE PIVOT

3⁵/₁₆" extension one pivot on pole only

- 500780590** Black
- 500780530** White
- 5007805140** Polished Chrome



DUAL PIVOT

11⁵/₁₆" extension with two pivot points

- 500781090** Black
- 500781030** White
- 5007810140** Polished Chrome



SINGLE ARM LCD FLAT PANEL DESK MOUNTS

- 11" sliding travel on the 12³/₈" post (amount of travel reduced based on the monitor being mounted)
- Includes grommet and clamp mount, clamping range of 0" – 3 1/2" grommet maximum surface thickness 2³/₄"
- 360° swivel monitor mount
- Handles monitors up to 20 lb (9 kg)
- Standard VESA Plate has 75mm x 75mm and 100mm x 100mm hole patterns as well as keyhole slots for easy monitor connection



TRIPLE PIVOT

19⁵/₈" extension with three pivot points

- | | | |
|------------------|------------------|-------------------|
| Black | White | Polished Chrome |
| 500781590 | 500781530 | 5007815140 |



TRIPLE PIVOT WITH HEIGHT ADJUSTABLE SEGMENT

Each arm has 23⁵/₈" extension with three pivot points, 12³/₈" free floating counter balanced height adjustment, and easy-to-use Allen wrench adjustment to counter balance the weight of the monitor.

- | | | |
|------------------|------------------|-------------------|
| Black | White | Polished Chrome |
| 500781690 | 500781630 | 5007816140 |

MONITOR SUPPORTS

FLOTA SERIES MONITOR ARMS

SINGLE MONITOR GAS SPRING ARM LCD FLAT PANEL DESK MOUNT – HEIGHT ADJUSTABLE

Gas Spring Monitor Arm allows for effortless height, depth and angle adjustments. Easily adjusts to monitors between 4-8 kg/9-17 lb Includes hardware for clamp and grommet desktop mounting. The monitor arm provides over a 530 mm (19.5") reach and swivels 360 degrees around the base. The monitor mounts provide generous tilt angles and can be positioned in landscape and portrait viewing positions. Monitor mounting brackets include both 75 mm and 100 mm hole patterns to comply with VESA standards. Wire management clips included.

Silver

500LCD02100



XTEND LCD MONITOR ARM

- Class-leading 26" reach and 13" of usable height adjustment.
- Pole-less design for optimal space and storage.
- Counterbalanced spring technology allows for a 2 to 14lb. load
- 360° around the base, increasing the options for display position
- Tool-less clamp installation makes assembly quick and easy.
- Ideal for use with iPad Holder **5007803XXX**, page 36

Black

Silver

White

500781990

5007819100

500781930



SLIM FLOATING LCD ARM

- The sleekest, easiest to use, full-function monitor arm on the market. Floats monitors above the desk, where they can be effortlessly repositioned.
- The arm includes a configurable mount which enables desk edge, grommet and through-desk mounting.
- Powered by Better Balance® technology, supports the monitor with true constant force, ensuring smooth movement
- Handles monitors up to 7-20 lb (3-9 kg)

Black

Silver

White

5005790

50057106

5005730



SINGLE SCREEN, DOUBLE EXTENSION, HEIGHT ADJUSTABLE

- Double Extension models allow 25 1/8" of back and forth movement. Arm folds back to post for more desk space
- The arm swivels 360° around the base, increasing the options for display position
- Options are available for panel, wall and slatwall mounting configurations
- Desk clamp and grommet mount hardware are included
- Handles monitors up to 20 lb (9 kg)
- With a clamping range of 1/2" to 2 3/4" that is standard, this new arm will fit to any work surface
- New cable manager keeps all cables hidden
- Monitor mounting bracket, with Quick Connect option, contains 75x75mm, 100x100mm, 200x200mm and 100x200 hole patterns to meet with VESA standards
- 11" of sliding travel on a 12 3/8" post (excluding monitor)

Black	Silver	White	Polished Chrome
500781890	5007818100	500781830	5007818140



SINGLE PIVOT WALL MOUNTABLE LCD ARM



5006211106

- Single pivot point allows movement left to right
- 360° monitor rotation
- Up and down tilt
- Complete with 75 mm and 100 mm VESA brackets
- Holds up to 17.6 lb, (8 kg)

DUAL PIVOT WALL MOUNTABLE LCD ARM

5006212106

- Two pivot points allows for left to right plus back and forth movement
- 360° monitor rotation
- Up and down tilt
- Complete with 75 mm and 100 mm VESA brackets
- Holds up to 17.6 lb, (8 kg)



TRIPLE PIVOT WALL MOUNTABLE LCD ARM

5006213106

- Three pivot points allows for left to right plus back and forth movement (520 mm reach is ideal for deep work surfaces)
- 360° monitor rotation
- Up and down tilt
- Complete with 75 mm and 100 mm VESA brackets
- Holds up to 17.6 lb, (8 kg)



SLAT WALL MOUNTABLE LCD ARMS

- 360° monitor rotation
- up and down tilt
- complete with 75 mm and 100 mm VESA brackets
- Holds up to 17.6 lb, (8 kg)

Single pivot point allows movement left to right

5006241106

Two pivot points allows for left to right plus back and forth movement

5006242106

Three pivot points allows for left to right plus back and forth movement (520 mm reach is ideal for deep work surfaces)

5006243106



LCD FLAT PANEL ARMS WALL / SLATWALL MOUNT

- Meets VESA Standards
- 10 to 20 lb (4.5-9 kg) monitor range

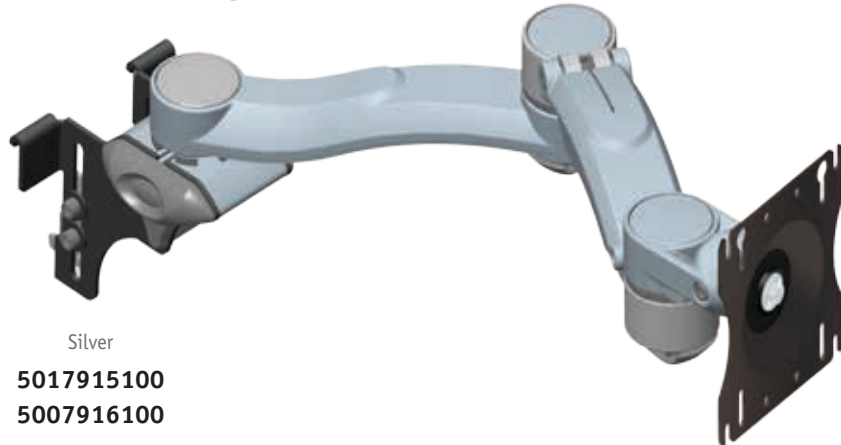

Black

Silver

Single-Screen, Slatwall Mount

501791590

5017915100

Single-Screen, Wallmount

500791690

5007916100

ALUMINUM TOOL BAR

TOOLBAR,
CLAMP TYPE
51" w* x 17" h

9910110

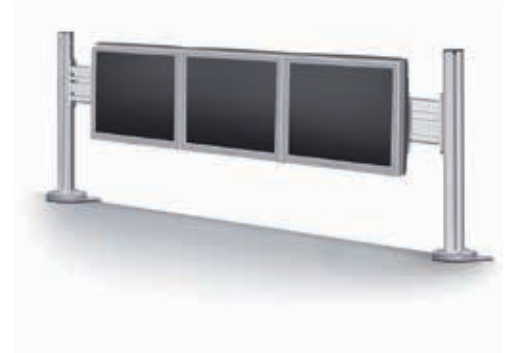

TOOLBAR,
CLAMP TYPE
51" w* x 28" h

9910210

TOOLBAR,
WALL MOUNT
51"

9910310



TOOL BAR MOUNTABLE LCD ARMS

- Weight Capacity: 8.8-13.2 lb (4-6 kg)
- Up and down tilt
- Rotation: 180° for portrait or landscape viewing (right & left)
- High quality Aluminum alloy
- Universal Slat Mount Type (Track)
- Meets Vesa standards



99693610
One pivot point plus tilt



99692610
353 mm extension with two pivot points plus tilt

MONITOR SUPPORTS

DUAL ARM LCD FLAT PANEL DESK MOUNT

- Meets VESA Standards
- 10 to 20 lb (4.5-9 kg) monitor range
- Includes clamp and grommet mounts
- Handles monitors to 20 lb (9 kg) - 20" max width
- 12 3/8" post travel

Black Silver
500792590 5007925100

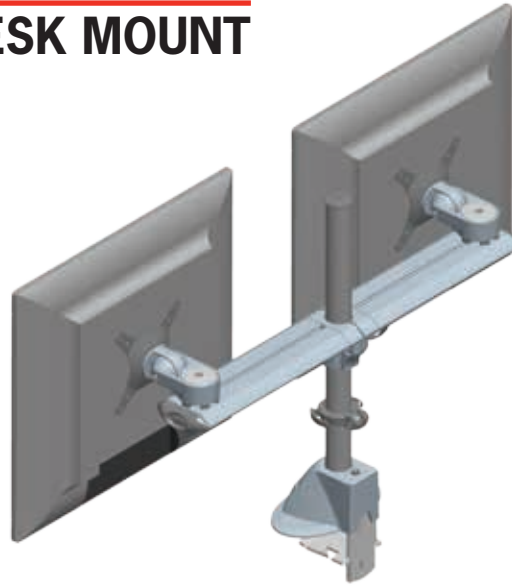

DUAL PIVOT DESK MOUNTABLE LCD DUAL ARM

5006224106

- Two pivot points on each arm allows monitors to be side by side or back to back
- 360° monitor rotation
- Up and down tilt
- 100 mm of spring assisted tool less height adjustment
- Complete with 75 mm and 100 mm VESA brackets
- Holds monitors weighing up to 8.8 lb, (4 kg) each



TRIPLE PIVOT DESK MOUNTABLE LCD DUAL ARM

5006225106

- Three pivot points on each arm allows monitors to be side by side or back to back
- 360° monitor rotation
- Up and down tilt
- 100 mm of spring assisted tool less height adjustment
- Complete with 75 mm and 100 mm VESA brackets
- Holds monitors weighing up to 8.8 lb, (4 kg) each



FLOTA SERIES MONITOR ARMS

DUAL MONITOR DOUBLE EXTENSION ARM LCD FLAT PANEL DESK MOUNT - HEIGHT ADJUSTABLE

Includes hardware for clamp and grommet desktop mounting. The monitor arms provides a 493 mm reach and have a large vertical adjustment on a 440 mm pole. The monitor mounts provide generous tilt angles and can be positioned in landscape and portrait viewing positions. Monitor mounting brackets include both 75 mm and 100 mm hole patterns to comply with VESA standards.

- Number of Monitors: 2
- Monitor Rotation: 310 degrees
- Type: Triple Pivot
- Capacity: 0 – 8 kg (0 – 17.5 lb) per monitor
- Mounting: Clamp or Grommet

Silver

500LCD23100



DUAL MONITOR GAS SPRING ARM LCD FLAT PANEL DESK MOUNT - HEIGHT ADJUSTABLE

Gas Spring Monitor Arm allows for effortless height, depth and angle adjustments. Easily adjusts to monitors between 4 – 8 kg. Includes hardware for clamp and grommet desktop mounting. The monitor arms provides over a 530 mm reach and individual adjust on a 440 mm vertical pole. The monitor mounts provide generous tilt angles and can be positioned in landscape and portrait viewing positions. Monitor mounting brackets include both 75 mm and 100 mm hole patterns to comply with VESA standards.

- Number of Monitors: 2
- Monitor Rotation: 310 degrees
- Type: Triple Pivot
- Capacity: 4 – 8 kg (8.8 – 17.5 lb) per monitor
- Mounting: Clamp or Grommet

Silver

500LCD22100

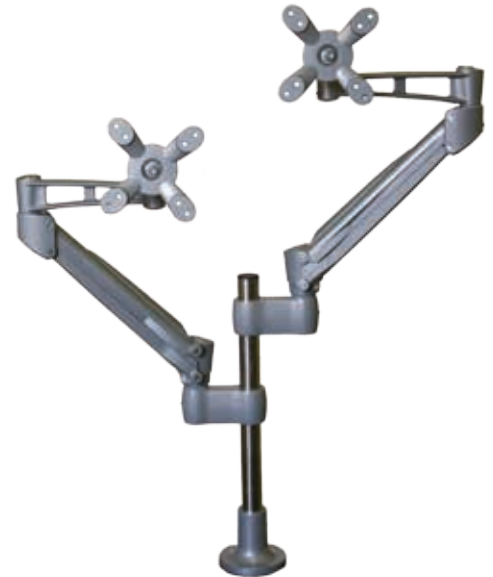

DUAL MONITOR GAS SPRING ARM LCD FLAT PANEL DESK MOUNT - HEIGHT ADJUSTABLE

Gas Spring Monitor Arm allows for effortless height, depth and angle adjustments. Easily adjusts to monitors between 4 – 8 kg. Includes hardware for clamp and grommet desktop mounting. The monitor arms provides over a 530 mm reach and have a large vertical adjustment on a 440 mm pole. The monitor mounts provide generous tilt angles and can be positioned in landscape and portrait viewing positions. Monitor mounting brackets include both 75 mm and 100 mm hole patterns to comply with VESA standards.

- Number of Monitors: 2
- Monitor Rotation: 310 degrees
- Type: Triple Pivot
- Capacity: 4 – 8 kg (8.8 – 17.5 lb) per monitor
- Mounting: Clamp or Grommet

Silver

500LCD21100

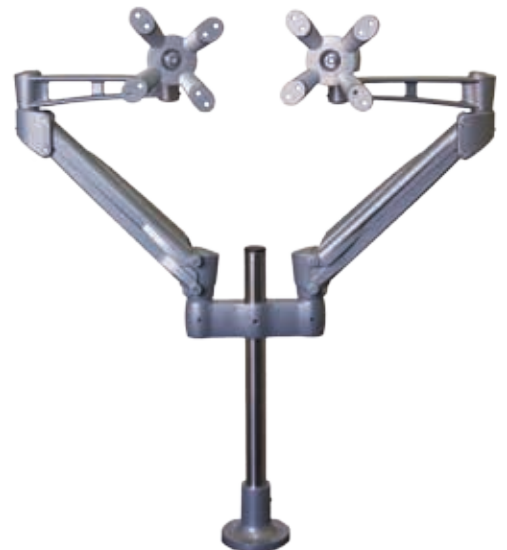

MONITOR SUPPORTS

DUAL MONITOR HUB

- The Hub has a locking device to allow it to be firmly clamped to the pole, as well as preventing the hub from rotating, thereby eliminating any play from the monitors, while still allowing the monitor to tilt and swivel
- Keeps the monitors at the same height
- Hub provides the end-user with the ability to mount two monitors
- Handles monitors 6-20 lb (2.5-9 kg) - 39" max width
- Desk clamp and grommet mount hardware are included.
- Cable manager keeps all cables organized
- Monitor mounting bracket, with Quick Connect option, contains 75x75mm and 100x100mm hole patterns to meet with VESA standards



	Black	Silver	White
Dual Screen	500782490	5007824100	500782430

DUAL ARM LCD FLAT PANEL DESK MOUNTS

- 11" sliding travel on the 12³/₈" post (amount of travel reduced based on the monitor being mounted)
- Includes grommet and clamp mount, clamping range of 0" - 3¹/₂" grommet maximum surface thickness 2³/₄"
- 360° swivel monitor mount
- Handles monitors up to 20 lb (9 kg) - 32" max width
- Standard VESA Plate has 75mm and 100mm hole patterns as well as keyhole slots for easy monitor connection
- Each arm has 19⁵/₈" extension with three pivot points



Black	White	Polished Chrome
500782090	500782030	5007820140

DUAL MONITOR TRIPLE PIVOT WITH HEIGHT ADJUSTABLE SEGMENT

- Each arm has 23⁵/₈" extension with three pivot points,
- 12³/₈" Free floating counter balanced height adjustment,
- Easy-to-use Allen wrench adjustment to counter balance the weight of the monitor.
- Handles monitors up to 20 lb (9 kg) - 32" max width

Black	White	Polished Chrome
500782190	500782130	5007821140



XTEND DUAL MONITOR ARM

- Best in class arm provides 26" of reach with 13" of usable height adjustment.
- Visually appealing pole-less monitor arm folds into a 4-3/8" area for more desk space in smaller work environments.
- Tool-less clamp installation makes assembly quick and easy.
- Flexibility and more options for the end user with a simple, easy-to-use Allen wrench adjustment to counterbalance the weight of the monitor.
- With a clamping range of 0" to 2 5/8" (clamp) that is standard for the Xtend, this arm will fit to any work surface.
- Enclosed cable management system hides cables.
- Counterbalanced spring technology allows for a 2 to 14lb. load (no gas leakages from use of gas cylinders)
- The arm swivels 360° around the base, increasing the options for display position.
- Choice of colors – silver, white or black.
- Made in Canada - TAA compliant. Meets GSA bid requirement.

Black	Silver	White
500782290	5007822100	500782230



DUAL MONITOR ARM TWO DOUBLE-EXTENSION ARMS

- The Hub has a locking device to allow it to be firmly clamped to the pole, as well as preventing the hub from rotating, thereby eliminating any play from the monitors, while still allowing the monitor to tilt and swivel
- Desk clamp and grommet mount hardware are included
- Cable manager keeps all cables organized
- Handles monitors up to 20 lb (9 kg) - 36" max width
- Monitor mounting bracket, with Quick Connect option, contains 75x75mm and 100x100mm hole patterns to meet with VESA standards

Black	Silver	White
500782590	5007825100	500782530



DOUBLE EXTENSION ARM

- Double Extension models allow 25 1/8" of back and forth movement. Arm folds back to post for more desk space
- The arm swivels 360° around the base, increasing the options for display position
- Options are available for panel, wall and slatwall mounting configurations
- Desk clamp and grommet mount hardware are included
- Handles monitors 6-20 lb (2.5-9 kg) - 38" max width
- Clamp and grommet adjustable to fit most desks and work surfaces
- New cable manager keeps all cables hidden
- Monitor mounting bracket, with Quick Connect option, contains 75x75mm, 100x100mm, 200x200mm and 100x200 hole patterns to meet with VESA standards

Black	Silver	White
500782390	5007823100	500782330



MONITOR SUPPORTS

TRIPLE MONITOR HUB

- The Hub has a locking device to allow it to be firmly clamped to the pole, as well as preventing the hub from rotating, thereby eliminating any play from the monitors, while still allowing the monitor to tilt and swivel
- Keeps the monitors at the same height
- Hub provides the user with ability to mount three monitors on a single pole.
- Handles monitors to 20 lb (9 kg) - 18" max width
- Cable manager keeps all cables organized
- Monitor mounting bracket, with Quick Connect option, contains 75x75mm and 100x100mm hole patterns to meet with VESA standards

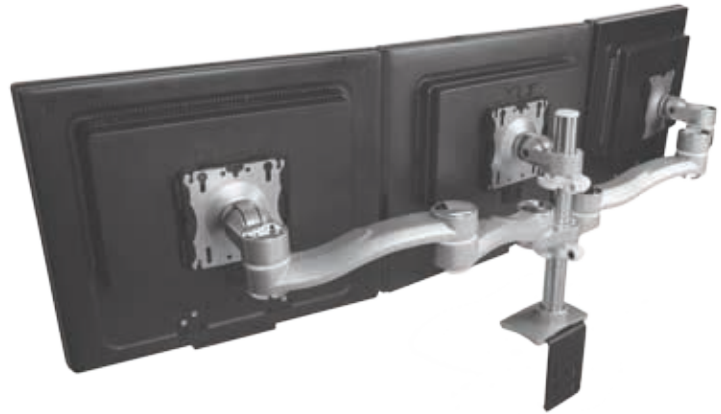

Black Silver White
500783090 500783100 500783030

FLOATING DUAL LCD ARM WITH VERTICAL/HORIZONTAL POSITIONING



- Gas arm "floats" monitors above desktop for instant height adjustment
- Monitors can be positioned horizontally (side-by-side) or vertically (stacked one over another)
- Includes FLEXmount™
- Quick-install/quick-release mechanism instantly and securely snaps monitors into position
- Compatible with all VESA® monitors – includes 75mm and 100mm VESA® mounting plates
- Includes cable management system – cables concealed in arm
- Accommodates monitors up to 24" widescreen (monitor widths may vary) combined monitor weights 9-21 lb (4-9.5 kg)

Black Silver
5007490 50074106



FLOATING LCD MONITOR ARMS

- Adjust base height of monitors on pole in 1" increments
- Each arm has 24" of horizontal range
- Each arm has 16" of vertical range (8" up and down from horizontal)
- Each arm can fold up to occupy just 3" of space
- Each arm rotates 360° at three joints
- Monitor tilting mechanisms tilt over 200°
- Includes FLEXmount™ with 6 mounting options.
- 75mm & 100mm VESA adapters included.
 Please call for non-VESA options.

LCD ARM

- Extends up to 24" with 16" vertical range
- Tilt monitor up to 200°
- Balances screens 4 to 14.5 lb (1.8-6.6 kg)
- Integrated cable management
- Includes 75mm & 100mm VESA® Brackets, Grommet Clamp and Wall Mount

Black Silver
5007090 50070106

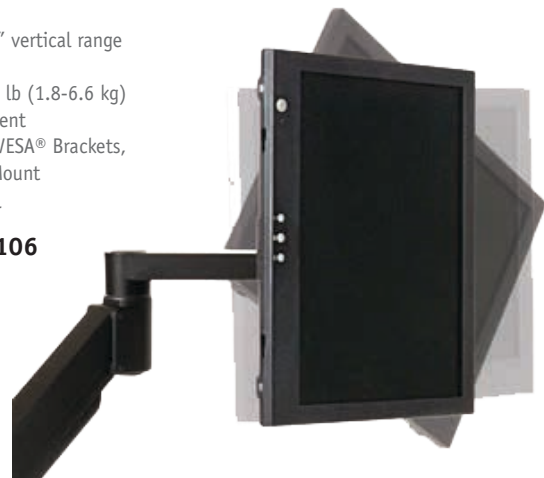

FLOATING LCD MONITOR ARMS CONTINUED



To achieve this configuration in black:
 2 - 5007090 Arms
 1 - 50071290 Pole
 1 - 5007290 Brackets



EXTENDER TUBE

- Raise the height of your arm by 6"
- Does not impede 360° rotation.

Black	Silver
5007690	50076106



POLES

- Includes wire management guides

	Black	Silver
14"	50071290	500712106
28"	50072490	500724106



BRACKET

- 360° rotation.
- Slides on pole for easy adjustment

Black	Silver
5007290	50072106

MOUNTING BRACKET

- Clamp on bracket

Black	Silver
5007390	50073106

LAPTOP HOLDER

50078090

- Adjustable laptop bracket accommodates laptops of most sizes.
- Monitor tilter mechanism can tilt over 200 degrees
- Optional 6" extender tube available to raise monitor (5007690, 50070106)
- *Requires 5007090 or 50070100 Arm



To achieve this configuration in black:
 4 - 5007090 Arms
 1 - 50072490 Pole
 2 - 5007290 Brackets

MONITOR SUPPORTS

TRIPLE FLAT PANEL MOUNT

- Flexibility and more options for the end user with a simple, easy-to-use Allen wrench adjustment to counter balance the weight of the monitor.
- Double Extension models allow 20" of back and forth movement.
- Arm folds back to post for more desk space
- Handles monitors up to 20 lb (9 kg) - 18" max width
- Options are available for panel, wall and slatwall mounting configurations
- Monitor mounting bracket contains both 75mm and 100mm hole patterns to comply with VESA standards
- Pole allows manual height adjustment of 12 3/8"

Black	Silver	White
500783590	5007835100	500783530

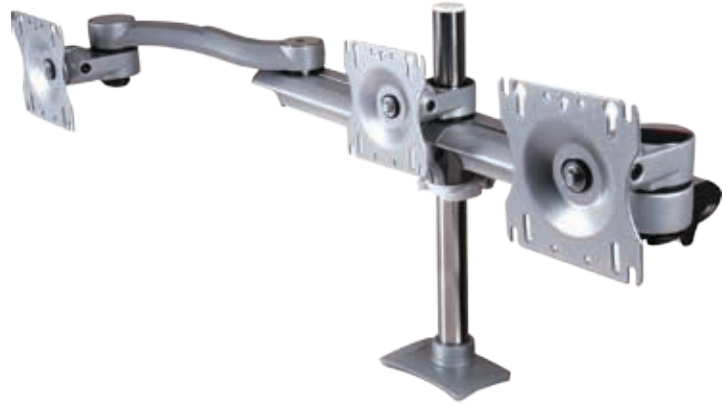

MULTIPLE MONITOR DESK MOUNT



Quad-Screen, Beam Mount (Max 20" width)
Six Screen Beam Mount (Max 24" width)

Black	Silver
500794590	5007945100
500796090	5007960100

- Meets VESA Standards
- Handles monitors up to 20 lb (9 kg)
- Includes clamp and grommet mounts

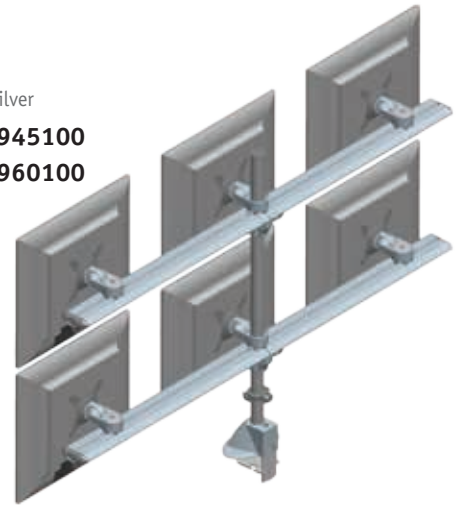

PARABOLIC MULTIPLE MONITOR DESK MOUNT

- Meets VESA Standards
- Handles monitors up to 20 lb (9 kg) - 20" max width
- Includes clamp and grommet mounts



Black Silver

Parabolic Quad-Screen Beam Mount	500794090	5007940100
Parabolic Octo-Screen Beam Mount	500798090	5007980100



LCD ARM MOUNTABLE LAPTOP HOLDER

5002310

- Adjustable brackets keep laptop in place
- Mounts to any LCD arm that meets standard Vesa mounting
- Front-mounted handle for easy adjustments
- Fits laptops (diagonal): 12.1/8" - 15.3/8"
- Metal construction
- Silver



LCD ARM MOUNTABLE LAPTOP HOLDER

Black

White

Silver

5007801190

5007801130

5007801100



Arm sold separately.

LAPTOP HOLDER

50078090

- Adjustable laptop bracket accommodates laptops of most sizes.
- For ultrathin laptops or tablet PCs, the clips can be attached to the clasps for a secure grasp.

*Requires 5007090 Arm



Arm sold separately.

Vesa Adapter Plate
• 100mm X 200mm
• Works with all lcd arms
500780490



LAPTOPS AND IPADS HOLDERS

LCD ARM MOUNTABLE LAPTOP HOLDER WITH DOCUMENT HOLDER

Black

White

Silver

5007801290

5007801230

50078012100

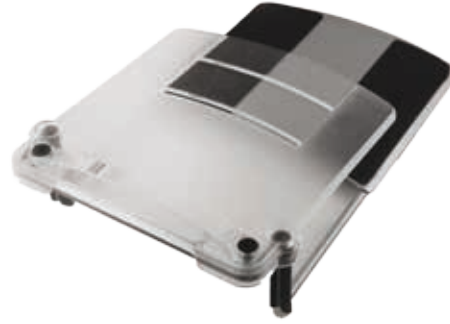

LCD ARM MOUNTABLE DOCUMENT HOLDER

Silver

50078012140



IPAD HOLDER

- Mounts directly to standard VESA 100 mm bracket
- Works with most monitor arms.
- Holds iPad upright in landscape or portrait view
- Stable steel cradle design
- Non-slip cushioned cradle to hold iPad firmly in place
- Cutout-style cradle to accommodate cables
- Supports all iPad models

Black

Silver

White

500780390

5007803100

500780330



Arm sold separately.



LOCKING LAPTOP DRAWER

50050290

Locking Laptop Drawer provides both storability and security. The quality 16 gauge metal construction smoothly rolls on 16" ball bearing slides. The added leatherette palm support provides ergonomic comfort when using your laptop. Locking mechanism with two keys ensures that your computer is safe when not in use. Two cord management holes allow easy access for external peripherals.

- Ventilation holes allow for laptop cooling.
- Overall Dimensions: 16" w x 16" d x 2" h
- Weight Capacity: 11 lb (5kg)
- 3" drawer slide depth (work surface bottom to underside of drawer)
- 16" ball bearing drawer slides for smooth rolling action

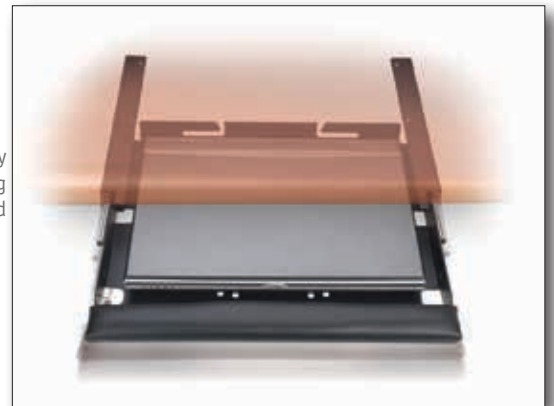

INTEGRATED COMPUTER SYSTEMS

To maximize the space and provide additional comfort, easy to fit in an existing furniture. The monitor placed under the working surface accommodates the reading (Downward GazeMC). This proper position brings relief from computer eyestrain and muscular tension.

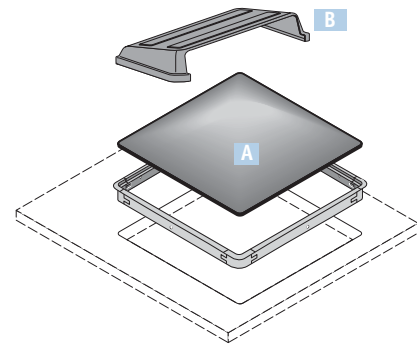
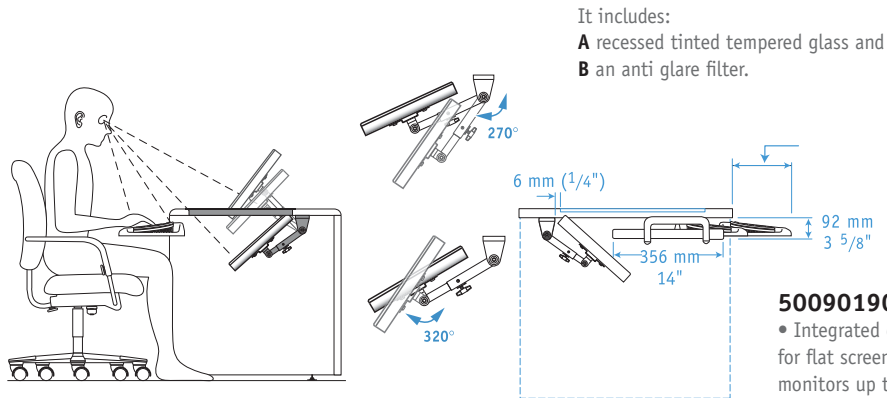

50090190

- Integrated computer system for flat screen* supports monitors up to 9 lb

50090290

- Integrated computer system for flat screen* supports monitors up to 21 lb

MANUAL MONITOR LIFT

Manually operated device designed to hold TV monitors and computer screens in freestanding desks, workstations, and cabinets. When the monitor is not in use, it can easily be pushed down into the desk to maximize the desktop surface.

500981090

- Convenient, secure storage
- Multiple hole mounting configuration on fixed mounting plate provides ample attachment points for any mounting application
- Simple to operate "Push to Open, Push to Lock" feature provides positive locking in stored position
- Five 1lb. weights are provided to counterbalance from 5 to 14 lb

PLEASE NOTE THAT PRODUCT REQUIRES THE FOLLOWING TO FUNCTION:
 5009801A90 counterweight kit
 5009801B90 lid attachment kit

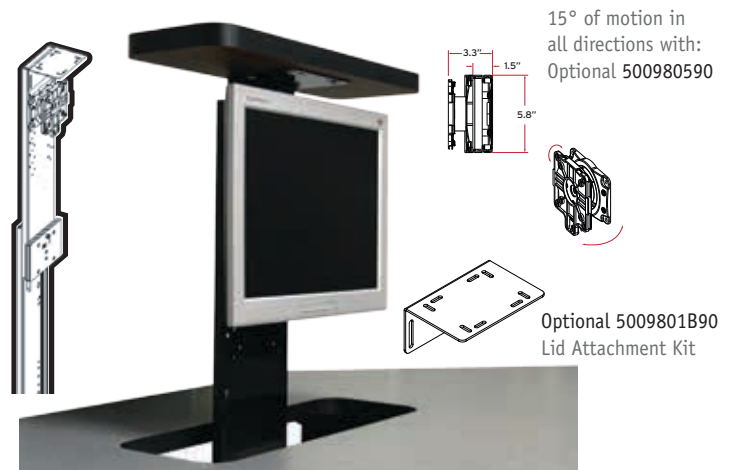

TROLLEY MONITOR LIFT



50091190 lcd trolley up to 20" screens

50091290 lcd trolley up to 24" screens

- Electric motor driven lift
- Auto Retractable Access doors
- Push button activation control
- Vertical tilt monitor adjustment
- Wire management
- Intelligent Motion Technology™
- Work surface foot print dimensions: 8½" D x 28½" W
- Made from 100% recyclable materials

MOBILE COMPUTER CART

- 27" footprint polished aluminum base
- Five 3" non-marking, light-duty industrial casters, 2 lockable
- 60" stainless steel pole (1 $\frac{1}{4}$ " in diameter)
- Concerto extension arm with 504204100 keyboard tray
- Lockable CPU holder with soft touch knob, increased stability and clamping force
- Multipurpose shelf (Printer/Laptop, etc)
- VESA compliant flat panel monitor head (75mm & 100 mm)

500780090

CUSTOM CONFIGURATIONS & ACCESSORIES AVAILABLE THROUGH CUSTOM ORDER

- Pole Mounted Keyboard Holder
- Multipurpose shelf



*Wall Mount Applications
Special order only*



Accessories



RC COMPACT MOBILITY KEYBOARD LAPTOP CART

Mobilize your laptop with this durable, adjustable mobile cart. Lightweight, compact with a small footprint, and simple to use, this cart is designed for healthcare applications where wall mounting is not an option.

- Lithium battery compartment
- Sit/stand height adjustment, 29"-41"
- Small, stable footprint
- Antimicrobial work surface
- 2 locking casters
- Includes mouse pocket
- Shipped fully assembled

508961100



Lithium battery compartment integrated into the cart top provides convenient storage with integrated cable management for a safe, uncluttered appearance.



The small 18 inch x 17 inch footprint is very stable in its low profile design, finished with high quality casters.

FLUID COMBO WALLCENTER

The Fluid wallcenter can be adjusted with a single-handed motion for maximum usability. Whether you are sitting or standing, you can move the arm from a completely stored position to any ergonomic position by using the grab handle integrated with the keyboard tray.

- Stores 7 inches from the wall
- Full keyboard and mouse tray
- Extends up to 37 inches to the keyboard
- Rotates 180 degrees
- Height adjustable LCD
- Ergonomically designed for multiple users

Track Size	Mount Style	
32"	Stud Mount	508931100
48"	Drywall Mount	508932100



Shown with 32" track

FLUID LCD DESKTOP WALLCENTER

This model features a full writing surface as well as a pull-out keyboard and mouse tray, making it a functional workstation for round-the-clock use in the most demanding environments. The desktop flips up when not in use.

- Full keyboard and mouse tray
- Extends up to 37 inches to the keyboard
- Rotates 180 degrees
- Height adjustable LCD
- Ergonomically designed for multiple users
- Above Keyboard Writing surface
- Sit/stand height adjustment
- Antimicrobial surfaces

Track Size	Mount Style	
32"	Stud Mount	508933100
48"	Drywall Mount	508934100



Shown with 48" track

FLUID OPTIONAL EXTENSION ARM

For use with any Fluid Wallcenter

- Increases rotation to 270 degrees
- Total 55" of reach
- Internal cable management
- Privacy achieved through rotation towards the wall
- Share the workstation between 2 patient beds
- When stored the workstation remains 7" from the wall

508937100



SWIVEL LIMITER FOR FLUID SERIES

- Incorporate with or without extension arm
- Provides incremental limited arm movement
- Ability to lock arm 90 degrees from wall
- Protects arm and furniture from damage
- One step installation

508938100



FUSION SLIM PROFILE WALLCENTER

This mount is designed to provide easy access to medical records in high-traffic, space-constrained areas. The Fusion system can be adjusted vertically with a single-handed motion for quick, ergonomic adjustment. The keyboard flips up when pressure is removed from the wrist rest.

- Stores 4 inches from the wall when not in use
- Smooth counterbalanced adjustment through 12 inches
- Sit to stand positioning
- Locking lever secures keyboard in place
- Auto flip keyboard

508941100



RX COMPACT WALL TRACK



This wall track is flexible and compact in design, and with excellent horizontal adjustment, can be configured to meet your needs. This mount works well in high-traffic and space-restricted areas such as hallways

- Independent 10 inch height adjustment of LCD and keyboard
- Perfect for touch panel or all in one panel PC's
- Meets strict fire code regulations for use in hallways

508942100



RX PIVOT LCD COUNTERBALANCE KEYBOARD WALL TRACK

This system features independently adjustable LCD and keyboard mounts on a 32" vertical track. The counterbalanced keyboard platform allows for quick adjustment to accommodate a variety of users.

- Keyboard folds up tight when not in use
- Independent 10 inch vertical adjustment of LCD and keyboard on track*
- Ergonomically designed for multiple users

508943100



ENCLOSED CPU MOUNT

Keep your CPU secure in this enclosed mount that professionally conceals and organizes both CPU and cables.

- Mount directly to wall or to universal wall track
- Multiple cable management access ports
- Ventilation on sides and top of mount

TRACK SOLD SEPARATELY

For use with Fluid & RX systems only, not compatible with Fusion

508993100



CPU CRADLES

Streamlined and adjustable, this CPU track mount frees up space and can be mounted at the top or the bottom of the CPU track.

- Mounts direct to wall track
- Frees up floor space and simplifies room cleaning
- Adjustable cradle to accommodate 4.25 to 8 inch CPU sizes
- Interior rubber tabs secure CPU

For use with Fluid & RX systems only, not compatible with Fusion

508991100 Adjustable cradle to accommodate 1.25 to 4 inch CPU sizes

508992100 Adjustable cradle to accommodate 4.25 to 8 inch CPU sizes



ANTI BACTERIAL PULLS

- Certified recycled content for LEED certification.
- Brass

Ref #	SKU	Center to Center	Overall Dimension Metric (mm)	Overall Dimension Imperial	Screw (Included)
1	93896	96	106 x 38 x 36	4-3/16 x 1-1/2 x 13/8	8/32
2	938128195AB	128	137 x 38 x 36	5-3/8 x 1-1/2 x 13/8	8/32
3	938192195AB	192	202 x 38 x 36	7-15/16 x 1-1/2 x 13/8	8/32
4	938224195AB	224	234 x 38 x 36	9-1/4 x 1-1/2 x 13/8	8/32
5	93232195AB	-	∅ 32 x 30	1-1/4 x 13/16	8/32
6	938203195AB	203	222 x 19 x 48	8-3/4 x 3/4 x 1-7/8	1/4 - 20
7	938305195AB	305	323 x 19 x 48	12-3/4 x 3/4 x 1-7/8	1/4 - 20

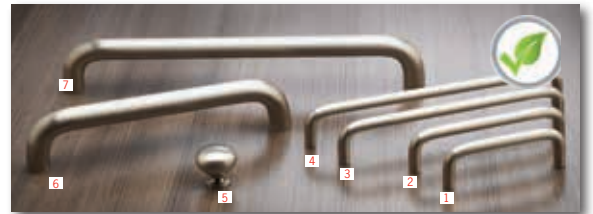

WALL CONNECTORS

- Ideal for glass, acrylic, and materials from 5 to 10 mm thick.

Height	55 mm (2 11/64 in)
Width	54 mm (2 1/8 in)
Thickness	25 mm (63/64 in)
Glass Thickness	5 to 10 mm (13/64 to 25/64 in)

BP3100174 Satin Chrome

BP3100195 Satin Nickel



CPU HOLDERS

STRAP CPU HOLDERS

Streamlined and adjustable device with an innovative strap support design. This enables the CPU to be off the floor or desk surface to create a space-saving solution. By elevating the unit, the users also benefit by its easy accessibility. CPU retracts on a 17" track and swivels to allow full accessibility and easy storage

Width Adjustment	Weight	Weight Capacity	Swivel	Track Size
2.5" - 64" Perimeter	4 lb	75 lb	360°	17"

- 500732290** Single Strap
- 500732590** Double Strap



LOCK & STORE™ CPU HOLDER EASYREACH™ CPU HOLDER

500736190

- Full 360° rotation
- Soft touch knob with built-in lock mechanism
- Low profile clamp
- Adjusts to fit CPUs 3" x 15" to 9" x 24"
- Teflon glide track
- Black finish



Also available:
500731190
Non swivel, non storable

500735190

- Full 360° rotation
- Low profile clamp
- Adjusts to fit CPUs 3" x 15" to 9" x 24"
- Teflon glide track
- Black finish

Also available:
500730190
Non swivel, non storable



CONVERTIBLE CPU HOLDER

500159890

- Mounts under desk with screws for quick installation
- Simple assembly adjusts to various CPU sizes (adjustable length 15" to 19", adjustable width 5.5" to 9.8")
- Three step conversion process to easily accept horizontal desktop CPUs or vertical tower CPUs



ECONO CPU HOLDERS

50011090

- Mounts CPU horizontally under desk to save space
- Adjustable width, from 5 1/4" to 9 1/4"
- Adjustable height, from 15 11/32" to 21 1/4"
- Swivels 90° to 180°
- Weight capability of 66 lb
- Black finish



SLIMLINE CPU HOLDERS

DESIGNED FOR SMALL CPU'S

- Mounts CPU vertically under the desk to save space
- Adjustable height and width to fit different CPU's
- Weight Capacity: ~10kg
- Adjustable width from 50 to 100mm and height from 200 to 358mm, w 2"-4" h 4"-14"
- Material: Steel



Fixed Mount **5005090**



Sliding and Swivel Mount **50050190**
• 180° Pivot

MOBILE CPU CART



500102

- Elevates CPU off floor
- Adjustable width, from 5 1/8" to 10"
- Thick foam pads cushion CPU and protect surface
- Black

PERNO TASK LIGHT

- Magnet for metal shelf installation or easily access the screw holes for wood shelf installation thanks to the 160° swivel feature.
- Includes fluorescent T5 tube, on/off switch, 9' ground power cord and screw kit for wood shelf mounting.
- Connect up to 8 lights max in line
- Silver finish will blend into most office shelving
- Metal / Wood Shelf Mount

PERNO II With all the same features and benefits as the Perno I but now with built in Occupancy Sensor Option, preset with 30 minute delay. Choice of On, Off or On with Sensor



Size	Wattage	Suggested shelf size	PERNO I	PERNO II	BLACK Wood Shelf Mount Only
			Silver	Silver	Black
24 5/8"	14w	30" - 42"	94E1424100	94ES1424100	-
36 11/32"	21w	42" - 48"	94E2136100	94ES2136100	-
48 1/4"	28w	48" - 60"	94E2848100	94ES2848100	-
18"	10w	24" - 30"	-	-	94E1018090
24"	14w	30" - 42"	-	-	94E1424090
36"	21w	42" - 48"	-	-	94E2136090
48"	28w	48" - 60"	-	-	94E2848090

TAZETTA TASK LIGHT

- Energy efficient T5 3500°K fluorescent lamp with electronic ballast TCLP compliant
- Stocked in black
- 13" mounting bar included
- Options available by special order include: Dimming, Occupancy Sensor, prismatic or batwing lens, Chicago fused plug, cord colors and rotations.

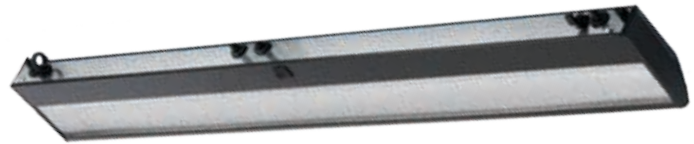

MOUNTING OPTION: SPRING STEEL MOUNTING BARS

	Size	Wattage	Suggested shelf size	Life cycle hrs
90450E13	12.97"	8w	18" to 24"	7,500
90450E24	23.23"	4w	30" to 42"	20,000
90450E36	35.04"	21w	42" to 48"	20,000
90450E48	46.87"	28w	48" to 60"	20,000
90450E60	58.66"	35w	60" to 72"	20,000

9049000	12.5"
9049003	14"

PURE DESK LIGHT

- Includes ONE high powered 5W CREE LED Chip Technology
- Strong goose neck arm 25" in length for complete flexibility & control of your light
- Matt silver finish with black base
- 3 step dimmer function built into base for easy control of light levels with just a single touch 30%, 60% & 100%
- Lumen: 530, Neutral white color temperature 4,100°K
- Base measures: 7-3/4" x 5-1/4"

2089090



PERNO "L" LED TASK LIGHT

WITH BUILT-IN ON/OFF OCCUPANCY SENSOR

Introducing Richelieu's Perno "L" III with all the same features and benefits as the Perno, Now in LED format with built-in Occupancy Sensor option, preset with 30 minute delay.

ADVANTAGES AND BENEFITS

- Perno L silver finish will blend into most office shelving.
- Convenient white on/off switch or occupancy sensor located on the fixture.
- Magnet installation makes for quick and easy installation, no need to worry about additional installation bars for metal shelving.
- Magnet installation accommodates all metal shelving also included are screws for wood shelf installation.
- Aluminum body construction.
- The 160° swivel feature of the Perno L Task Light allows the user to position the light where needed.



PRODUCT NUMBER	Watts	Length	Luminous Flux
94ELS0618100	6 W	18 25/32 in	401 Lumen
94ELS0824100	8 W	24 17/32 in	609 Lumen
94ELS1436100	14 W	36 11/32 in	997 Lumen
94ELS1848100	18 W	48 15/64 in	1,235 Lumen

PRIME LED TASK LIGHT



Fixture	Size	Suggested shelf size	Watts	Color
26121090	20"	Minimum 22"	7.5w	Black
26121100	20"	Minimum 22"	7.5w	Silver

- 180° swivel feature that allows for complete control
- Magnet for metal shelf installation or easily access the screw holes for wood shelf installation thanks to the 160° swivel feature
- Each light includes one 9' power cord, built in LED power supply and one 20" connecting cable
- Connect up to 100W max (total of 12 lights in line)
- Dimensions: 20 x 2 1/8 x 7/8"
- Average life: 50,000 hours

NOVA LED LIGHT

RICHELIEU'S NOVA LED LIGHT IS ENCASED IN THE STANDARD T5 HOUSING. NO NEED TO CHANGE YOUR DESIGNS OR RE-ENGINEER YOUR INSTALLATIONS, SIMPLY UPGRADE FROM THE STANDARD T5 FLUORESCENT TO THE NOVA!



- Includes one fixture, 4,100° K T5 housing, Plexiglas, hardware mounting kit (plastic clips & direct connector), and a convenient on/off switch located on the fixture.
- Requires the following product to function: **4511240070** LED Nova 6' Power Cord

	Wattage	#LED	Size
4511240413	4w	48	13 1/2 x 1 5/8 x 7/8
4511240823	8w	96	23 3/4 x 1 5/8 x 7/8
4511241435	14w	168	35 5/8 x 1 5/8 x 7/8
4511241847	18w	240	47 3/8 x 1 5/8 x 7/8

NOVA ACCESSORIES

6' Power Cord	4511240070
6" Connecting Cable	4511240006
12" Connecting Cable	4511240012
20" Connecting Cable	4511240020
40" Connecting Cable	4511240040

POWER MANAGEMENT

MINI POWER AND DATA SOLUTIONS

- Easily mounts to tables, desks, and work surfaces
- Unique swiveling 6' power cord adapts to each application
- Only add voice/data modules when needed
- Voice/data jacks mount flush, for a clean professional look
- UL and CSA listed
- Accommodates surface thicknesses up to 1½"
- Compatible with most voice/data jacks



50030503 Power only

50030506 Data & Power Combo

Phone & Data Jacks are sold separately.

50030512 RJ45 Data coupler

POWER HARNESS WITH COAXIAL/TEL

431190 3 outlets with 1 coaxial

431290 3 outlets with 1 phone

431390 3 outlets with 1 phone and 1 data connector

431490 4 outlets with 1 phone and 1 data connector



Can be surface or recess mounted

POP UP POWER SOLUTIONS

- Pull up handle for easy access to the pop up power bar
- Simple press to release the power bar and return it to the recessed position
- IP54 waterproof and dust proof design

	Plugs	USB	RJ45	Top	Finish
100492140	2	2	n/a	Aluminum	Chrome Satin
100492185	2	2	n/a	Aluminum	Nickel
100492090	2	2	2	Plastic	Black



TABLETOP POWER HARNESS WITH USB



	Plugs	USB	Size	Finish
201114100	1	2	5.4 x 5.3 x 2.7h	Silver/Matt black insert
201214100	2	0	5.4 x 5.3 x 2.7h	Silver/Matt black insert
201314100	3	2	10.5 x 4.7 x 2.7h	Silver/Matt black insert

GROMMET CHARGE PORT

A new way to charge items and get power at a work station while not using up any desk space



	Plugs	USB	Bore Hole	Finish
7188101090	1	1	60mm	Black
7188102090	0	2	60mm	Black

SURFACE POWER MODULES



- Round Power Station with 3 Outlets
- Easy installation
- Quickly adapts to any desk or conference table
- Outside diameter: 4⁵/₁₆"/110mm

100413090 Power, Universal RJ45 & RJ11



- 2 powered USB ports 2.1A
- 3 grounded outlets
- Combo Style, universal jack for both RJ45 and RJ11 connections
- Included 2 USB cables and power adaptor
- 10' grounded power cord
- Outside diameter: 4.33" (110 mm)
- Bore hole: 4.17" (106 mm)

100213090

SURFACE POWER MODULES

- 2 power outlets
- 2 receptacles for RJ11 or RJ45 adapters
- Cover stores out of the way when in use
- 6 ft power cord

50030500 Standard 110v receptacle

50030512 RJ45 Data coupler

Phone & Data Jacks are sold separately



COMMUNICATION AND POWER ACCESS BOX

- Available in 2 gang configurations for any combination of data, voice, fibre optics, fax, audio, video or power.
- Includes duplex power receptacle
- Field movable voltage barrier system.
- Fold away cover/door for easy access.

SQUARE ACCESS BOX

10041090 Black

100410170 Stainless steel

RECTANGULAR ACCESS BOX

10042090 Black

100420170 Stainless Steel

DOUBLE RECTANGULAR ACCESS BOX

10043090 Black

100430170 Stainless Steel

COUPLERS FOR ABOVE ACCESS BOXES

10045190 RJ11

10045290 RJ45

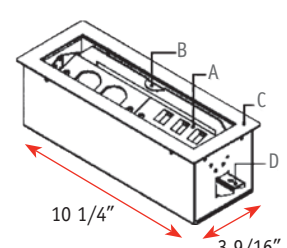
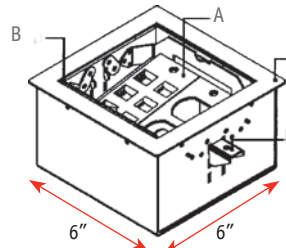
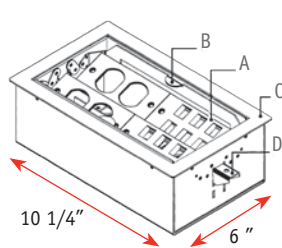

- A - Supports all structured data wiring systems
- B - Convenient flip-up covers for easy access
- C - Durable 16 gauge steel construction
- D - Adjustable hold-downs simplify rigid installation

WIRE MANAGEMENT AND GROMMETS

WIRE MANAGEMENT

WIRE CLIP
3309090



- Wire channel
- Peel and stick
- 1/2" x 1 1/16" x 96"

PF3411 Beige
PF3430 White



WIRE MANAGEMENT

	SIZE	COLOR
1691490	3 37/64" (91 mm)	Black
16914100	3 37/64" (91 mm)	Gray
16916100	5 5/16" (135 mm)	Gray
1691690	5 5/16" (135 mm)	Black



WIRE CHANNEL - PEEL & STICK
PF5690

- Wire channel
- Peel and stick
- 5 pieces / 6' lengths

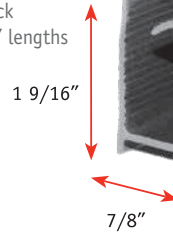

WIRE CHANNEL
SCREW OR STAPLE
512490

- Large wire channel
- 6' lengths

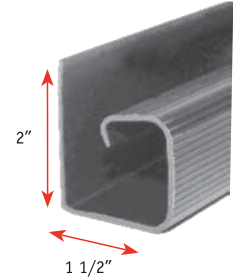

DOUBLE SIDED TAPE

- High strength acrylic adhesive on closed cell PE foam with a white conformable core.
- Polyethylene liner for easy removal.
- 216 ft roll

D031212 Black 1/2"

ALUMINUM WIRE MANAGEMENT

- Anodized Aluminum cable manager for hooded cables, satin finish
- Use pieces of profile cut in lengths of 1" to 1 1/2", flip 180° and fasten securely to the wall with screws.
- Easy to clean, use at home or in your office, perfect for lighting installation under cabinets.

7007628210 1/2" x 2 1/2 x 79" Rails

700762810 End Caps

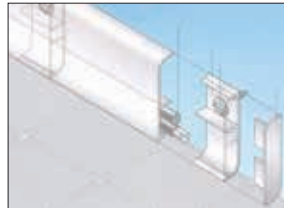

WIRE MANAGEMENT



HORIZONTAL CABLE GUIDE

Cable guide with 13 panel units .
Fits under a table top.

1689010 Aluminum
1689090 White
1689030 Black

VERTICAL CABLE GUIDE

Column grommet designed for tables with a maximum height of 28 11/32" (720 mm).

1672010 Aluminum
1672030 White
1672090 Black

508081106

- 800 mm aluminum profile
- Iron base
- Installed on base of desk, adaptable to all situations

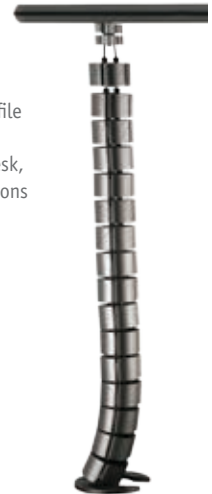

VERTICAL CABLE GUIDE

- 2400 mm / 94 31/64"
- Fits from a table to the ceiling,

1624010 Aluminum
1624090 White
1624030 Black

663000090

- Spiral tube in black plastic
- Cables may run through it
- Installed on base of desk, adaptable to all situations

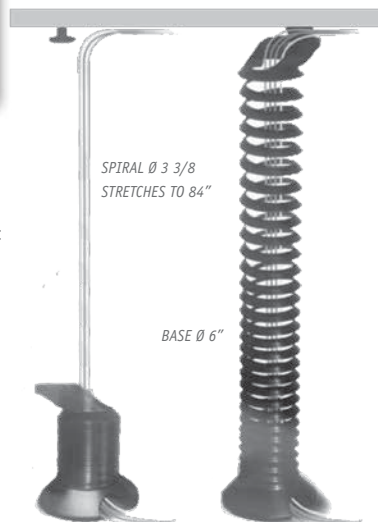

- 32-1/2", Separates wire in different channels for easier maintenance.
- Kit includes:
- 1 x top bracket
- 15 x spine wheels
- 2 x fixing clip (for horizontal applications)
- 1 x weighted base
- Length 900 mm / 35 7/16"

50808090 Black
50808106 Silver

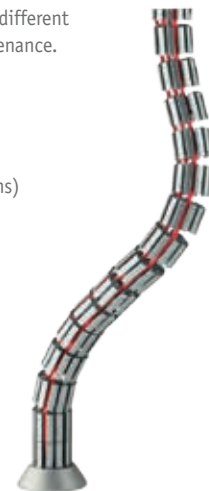

FLOOR MOUNTED CABLE HOLDERS

This cable storage system can be installed on the floor keep your room appearance neat. Pre-drilled for screws, or can be installed using double-sided adhesive tape.

208721810
208720110

2000 mm – 35 7/16"
14.5 cm – 5 3/4"

Aluminum Channel
Aluminum Elbow



GROMMETS

PLASTIC



	HEIGHT	BORE DIA.	AVAILABLE IN THE FOLLOWING COLORS (REPLACE XXX WITH CODE)
510XXX	5/8" (16.2 mm)	1 3/4" (44.8 mm)	30, 90
600XXX	5/8" (16.2 mm)	1 15/16" (48.2 mm)	30, 40, 60, 90
601XXX	5/8" (16.2 mm)	1 15/16" (48.2 mm)	100
760XXX	5/8" (16.2 mm)	2 1/2" (63.5 mm)	30, 40, 60, 90, 100
890XXX	5/8" (16.2 mm)	3" (76.2 mm)	30, 40, 60, 90, 100



	HEIGHT	BORE DIA.	OVERALL DIA.	AVAILABLE IN THE FOLLOWING COLORS (REPLACE XXX WITH CODE)
90060XXX	11/16" (18 mm)	2 3/8" (60 mm)	2 15/16" (75 mm)	30, 40, 60, 90, 100, 106
90044XXX	11/16" (18 mm)	1 3/4" (44 mm)	2 3/16" (55 mm)	30, 40, 60, 90, 100

FINISHES:

<input type="checkbox"/> 30 White	<input type="checkbox"/> 60 Brown	<input type="checkbox"/> 100 Gray
<input type="checkbox"/> 40 Almond	<input type="checkbox"/> 90 Black	<input type="checkbox"/> 106 Silver

METAL GROMMET FOR GLASS

- 608015170**
• 60mm Stainless Steel
- 60801510**
• 60mm Aluminum



METAL

	BORE DIA.	OVERALL DIA.	HEIGHT	FINISH
166012140	60mm (2- 3/8")	67mm(2- 5/8")	12mm (1/2")	Chrome
166012174	60mm (2- 3/8")	67mm(2- 5/8")	12mm (1/2")	Satin Chrome
16601290	60mm (2- 3/8")	67mm(2- 5/8")	12mm (1/2")	Black
168012140	80mm (3- 1/8")	88mm(3- 1/2")	12mm (1/2")	Chrome
168012174	80mm (3- 1/8")	88mm(3- 1/2")	12mm (1/2")	Satin Chrome
16801290	80mm (3- 1/8")	88mm(3- 1/2")	12mm (1/2")	Black
166021140	60mm (2- 3/8")	67mm(2- 5/8")	21.3mm (7/8")	Chrome
166021174	60mm (2- 3/8")	67mm(2- 5/8")	21.3mm (7/8")	Satin Chrome
16602190	60mm (2- 3/8")	67mm(2- 5/8")	21.3mm (7/8")	Black
168021140	80mm (3- 1/8")	88mm(3- 1/2")	21.3mm (7/8")	Chrome
168021174	80mm (3- 1/8")	88mm(3- 1/2")	21.3mm (7/8")	Satin Chrome
16802190	80mm (3- 1/8")	88mm(3- 1/2")	21.3mm (7/8")	Black



METAL GROMMET FOR GLASS
• Stainless Steel

- 20692170** 56 mm
- 20694170** 74.5 mm



	HEIGHT	COLOR
20910106	1" (25,4 mm)	Silver
2091090	1" (25,4 mm)	Black
2095890	5/8" (15,88 mm)	Black

RECTANGULAR GROMMET WITH BRUSH

Aluminum cover with straight flap, a black brush seal and smooth closing function.

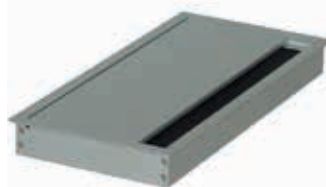

SQUARE GROMMET WITH BRUSH

Aluminum cover with straight flap, a black brush seal and smooth closing function.

2135115100

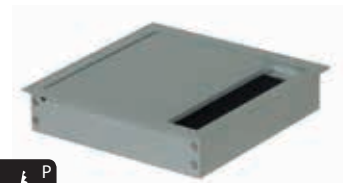

Product	Finish	Overall Width	Overall Depth	Drilling Width	Drilling Depth
2134278XXX	90, 100	12 19/32" (320 mm)	4 21/64" (110 mm)	12 13/32" (315 mm)	4 1/8" (105 mm)
2135206XXX	90, 100	9 29/64" (240 mm)	4 23/32" (120 mm)	9 1/4" (235 mm)	4 17/32" (115 mm)
2135322XXX	90, 100	17 23/32" (450 mm)	4 23/32" (120 mm)	17 33/64" (445 mm)	4 17/32" (115 mm)

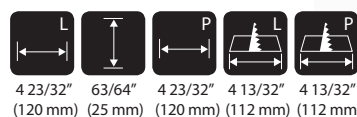

ACCESSORIES

HOLE SAWS

IDEAL FOR CUTTING WOOD, LAMINATE, SHEET METAL, THICK METAL, STAINLESS STEEL, AND PLASTIC.

- Teeth in cobalt alloy (8%) for longer life and higher heat resistance
- Works with standard or Quick Change mandrels (Quick Change requires adapters)
- Reinforced shoulder for added strength and longer life
- Progressor (TM) tooth design cuts faster and last longer
- 10° cutting angle for high performance



	Diameter.	
BSHB175	1 3/4"	44.45 mm
BSHB187	1.7/8"	47.625 mm
BSHB200	2"	50.8 mm
BSHB236	2 3/8"	60.325 mm
BSHB250	2 1/2"	63.5 mm
BSHB300	3"	76.2 mm
BSHB363	3 5/8"	92.075 mm
BSHB425	4 1/4"	92.1 mm
BSHB436	4 3/8"	11.113 mm

3/8" UNIVERSAL QUICK CHANGE MANDREL KIT

Included Product(s)

- 1 mandrel (3/8")
- 1 small adapter for hole saw sizes from 9/16" to 1-3/16"
- 1 large adapter for hole saw sizes from 1-1/4" to 6"

BSPCM38AN



GEL PALM RESTS



- 19" Premium single piece gel **GEL300K**
- 26-3/4" Premium single piece gel **GEL300M**
- 19" Premium gel kit, 19" keyboard & 4-3/4" mouse palm rest **500811990**
- For "Microsoft Natural" keyboard **GEL1590** (not shown)

PEEL & STICK PALM RESTS

	Foam	Gel
20"	500612090	500612090G
27"	500612790	500612790G



FOOT REST

Adjusts from 3" to 5" off floor

500EFR200



PEEL & STICK GEL MOUSE PADS

8" **GEL8595** - Recommended for Phenolic Series mouse trays

CORNER MAKERS

- Converts 90° corners to usable work areas
- Works with surfaces up to 1 1/2" thick



To create 18" diagonal, recommended for use with Momentum series

500179090

To create 28" diagonal, recommended for use to fill cut outs or where a wide keyboard tray is required

5001792890

PELICAN DRAWER

330090

- Large divided tray
- Lockable
- Large capacity storage bin
- Bin recessed for knee clearance
- Black finish

also available:

332090

File rails (1 pr)

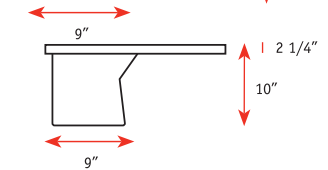
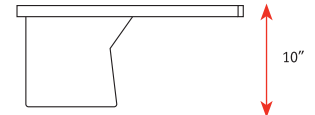
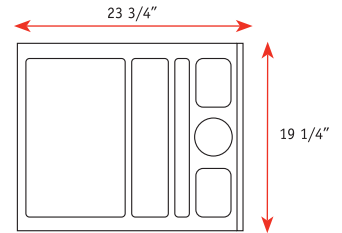

PELICAN II

333390

- Fully-concealed drawer slides.
- Retractable mouse tray.
- Soft, molded palm rest provides comfortable and correct support for keyboard.
- Large tray section for full-size keyboard or laptops.
- Full-length suspensions rails to protect against tampering with mounting screws.
- Mounts under any 23 3/8" (593 mm) deep surface. Fits all furniture systems.
- Key-core interchangeable locks compatible with most office furniture systems.
- Cable management.
- Suspension rails not included
- BIFMA-approved
- Mouse pad included: 8 1/2" x 8 1/2" (216 x 216 mm)

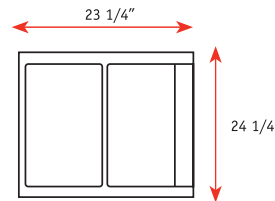

PELICAN III

330190

- Keyboard tray
- Comfortable palm rest
- Core interchangeable lock
- Retractable mouse tray
- Mouse tray
- High capacity storage bin, recessed for knee clearance
- Bin for CDs, etc.

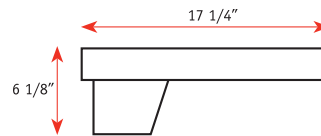

PENCIL DRAWER

BALL BEARING SLIDE

- With stationary box and ball bearing metal slides for mounting under desk
- Black finish

897190

- Large drawer

89300090

- Small drawer

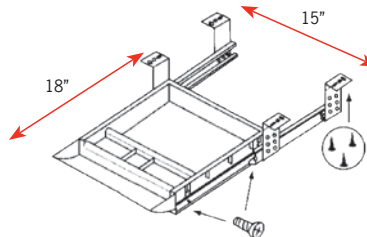
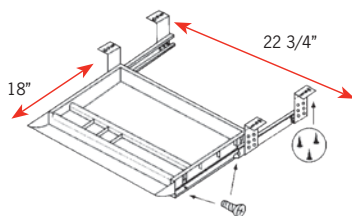

ROLLER SLIDE

897090

- With roller slides and frame for mounting under desk
- Black finish

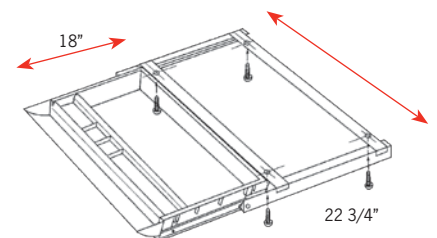

TRAYS AND DOCUMENT SUPPORTS

PENCIL TRAYS

506127590

- Black
- 6" x 12 3/4"



5081290

- Black
- 12 11/16" x 2 11/16"



5081590

- Black
- 12 3/4" x 5 5/8"



STAINLESS STEEL SHELF

- Stainless steel shelf for mounting under mirror.
- Gives a contemporary designer look to mirrors of the same size.
- Pre-perforated for easy installation.

18" **185518170**

24" **185524170**



FILE RAIL SYSTEM

500482190

- Corner bracket
- Mounts to inside of drawer and allows file bar to snap in



500482290

- Slider clip
- Instantly doubles your filing capacity



FILE BAR

71280810 Aluminum 8'

71281290 Black 12'

7128140 Chrome 8'



PLASTIC FILE HOLDER

124230 White 1/2"

124290 Black 1/2"

141230 White 5/8"

141290 Black 5/8"

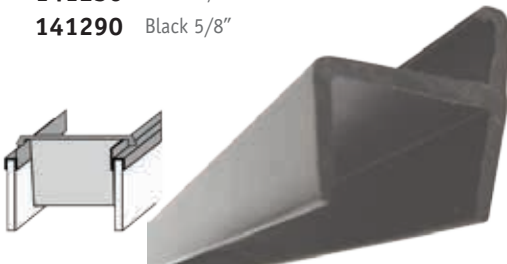

MODESTY PANEL CLIP

6646090

- Bracket for mounting modesty panels to 60 mm dia. legs (4 sets kit)



ABOVE DESK STORAGE SYSTEM

END POST



99200190
15"

CORNER POST



99200290
15"

SLAT RAIL



99202490
7" x 24" x 3/4"

99203690
7" x 36" x 3/4"

99204890
7" x 48" x 3/4"



ABOVE DESK STORAGE SYSTEM ACCESSORIES

BLACK FINISH

PHONE HOLDER



99100590
2" x 9 1/2" x 8 1/2"

ORGANIZER TRAY



99100490
2" x 10" x 9 1/2"

LEGAL-SIZE TRAY



99100790
2" x 10 1/2" x 15"

LETTER SIZE TRAY



99100390
2" x 9 1/2" x 14"

CD HOLDER (10)

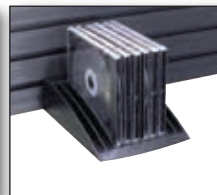

99100190
4" x 7" x 5 1/2"

GLASS/MUG HOLDER



99101490
4" x 2" x 5"

SHELF WITH BRACKETS



99102490
2" x 24" x 7"

PENCIL HOLDER



99100090
4" x 3 1/2" x 4"

BINDER HOLDER



99100990
9" x 10 1/2" x 5"

FILE HOLDER



99100890
2 1/2" x 12 1/2" x 7"

WHITEBOARDS AND TACKBOARDS

ECONOMY WHITEBOARDS

- Aluminum frame
- Includes fastener & pen rail
- Cost effective solution

MAGNETIC PAINTED METAL SURFACE

MBE2330 2' x 3' framed,

MBE3430 3' x 4' framed,

MBE4430 4' x 4' framed

MBE5430 5' x 4' framed

MBE6430 6' x 4' framed

MBE8430 8' x 4' framed

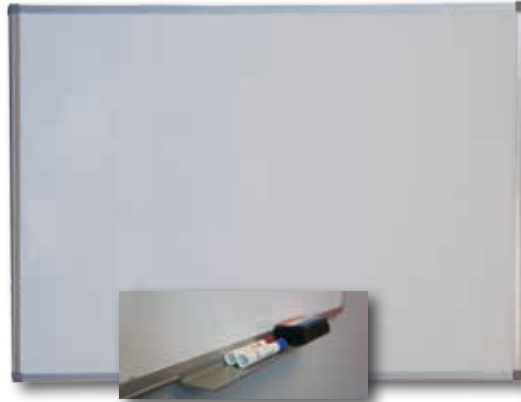

- Brackets are designed to work with MBE boards only.
- Made of clear anodized Aluminum.

Hanger Bracket 1-1/4" - 2-1/4"
MBEHB1210*

*Call for Quote

MAGNETIC WHITEBOARDS



WHITEBOARD PORCELAIN ENAMEL ON STEEL SURFACE

- A hard as glass porcelain enamel surface
- Attractive aluminum frame
- Dustless, ideal for computer rooms
- Durable and strong surface that is easy to write on and easy to erase
- Will not stain or discolor
- Magnetic surface
- 50 year warranty on writing surface
- Complete with mounting hardware
- Useable as a projection screen
- Stock color is white
- Custom sizes available through special order

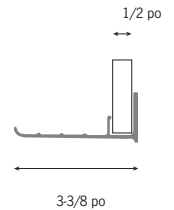

MB3004430 4' x 4' framed, complete with full-length marker trough

MB3006430 6' x 4' framed, complete with full-length marker trough

MB3008430 8' x 4' framed, complete with full-length marker trough

MB30012430 12' x 4' framed, complete with full-length marker trough

MBB1230 8' x 4' unframed

MAGNETIC SLIDING WHITEBOARDS

HORIZONTAL OR VERTICAL SLIDING WHITEBOARDS

All sizes available through custom order only

- Double your writing space
- Sliders are top suspended and glide easily on nylon roller bearing
- Rugged construction with top and side channels bolted together
- Dustless, ideal for computer rooms
- Durable and strong surface that is easy to write on and easy to erase
- Will not stain or discolor
- Magnetic surface
- 50 year warranty on writing surface
- Complete with mounting hardware
- Useable as a projection screen
- Stock color is white
- Custom sizes available through special order

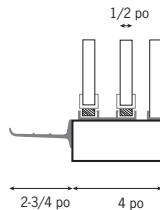

WHITEBOARD SUPPLIES

180669 Dry Erase Marker Red (Pack of 12)

180670 Dry Erase Marker Blue (Pack of 12)

180671 Dry Erase Marker Black (Pack of 12)

180672 Dry Erase Marker Green (Pack of 12)

1806734 Dry Erase Marker Assorted (Pack of 4)

180673 Dry Erase Marker Assorted (Pack of 12)

180227 Standard Sewed Eraser

180683 Whiteboard Cleaner



LOFLAME® VINYL TACKBOARDS

- Attractive vinyl fabric
- Popular color ranges
- Easy to clean
- Self-healing vinyl
- Laminated to 1/2" soft fibreboard
- Attractive aluminum frame
- Complete with mounting hardware
- Custom sizes available through special order

Early Warning Effect

- When heated above 300° Fahrenheit the wallcovering gives off a colorless odorless vapour that will set off the alarm on a ionization smoke detector.

Koroklear

- A protective coating that offers superior protection and a barrier against staining.



- TB30023*xxx** 2' x 3' framed
- TB30044*xxx** 4' x 4' framed
- TB30064*xxx** 6' x 4' framed
- TB30084*xxx** 8' x 4' framed
- TBB48*xxx** 8' x 4' unframed

* ADD CLOLOR CODES

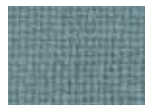

790
Breakwater

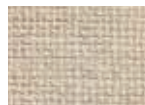

120
Desert Dust



231
Ice Blue



470
Sand Harbour



190
Sea Beach



613
Sugar Pink



910
Gray Feather



260
Sunbury



230
Antique White

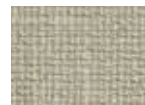

650
Surf

Colors may vary from swatches shown

CORKBOARDS

- Practical tackboard
- Excellent tackability
- Easy to clean
- Self-healing cork
- 0.8 mm cork laminated to 1/2" fibreboard
- Attractive Aluminum frame
- Complete with mounting hardware
- Custom sizes available through special order

- CT30022** 2' x 2' framed
- CT30044** 4' x 4' framed
- CT30064** 6' x 4' framed
- CT30084** 8' x 4' framed
- CTB716** 8' x 4' unframed

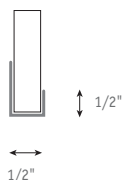

Office Dealer Dedicated Customer Service Number

www.richelieuergo.com

1-866-440-0448

ergoinfo@richelieu.com

Fax 1-800-382-8107

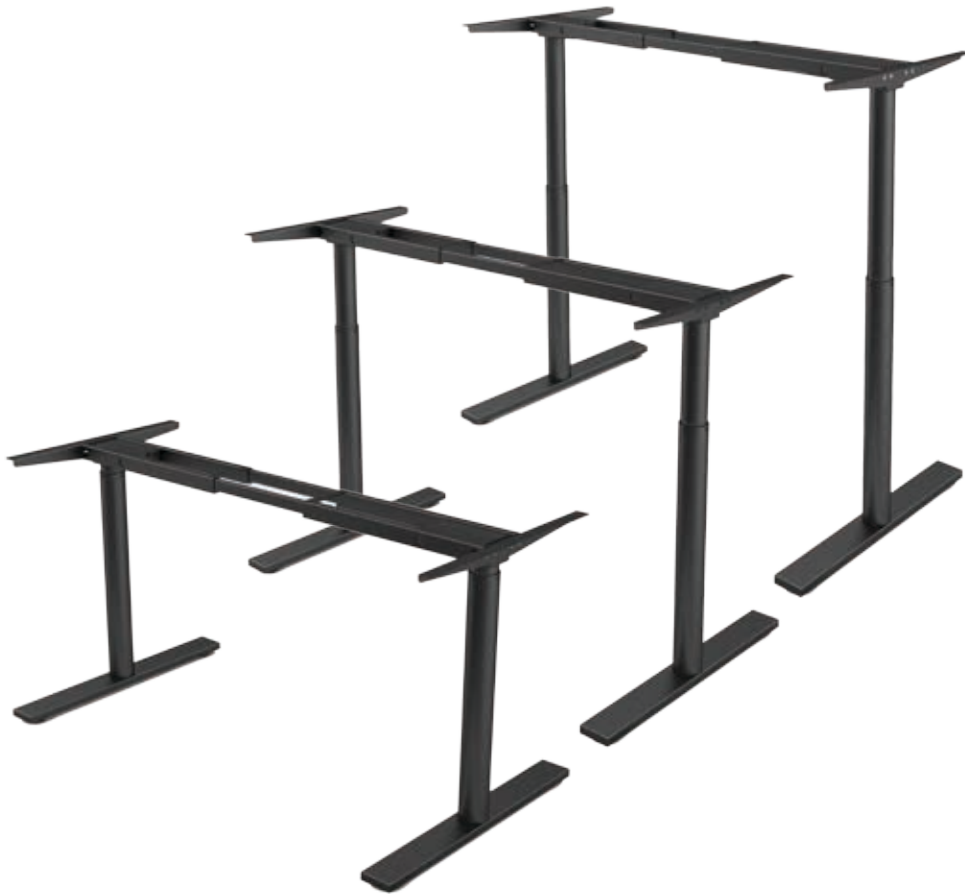

Touchboards

205 Westwood Ave, Long Branch, NJ 07740
Phone: 866-94 BOARDS (26273) / (732)-222-1511
Fax: (732)-222-7088 | E-mail: sales@touchboards.com

 **Richelieu**
richelieu.com

1-800-361-6000 Canada
1-800-619-5446 United States
info@richelieu.com

