

# Richelieu ERGO

**Touchboards**

205 Westwood Ave, Long Branch, NJ 07740  
Phone: 866-94 BOARDS (26273) / (732)-222-1511  
Fax: (732)-222-7088 | E-mail: sales@touchboards.com



500LCD02100

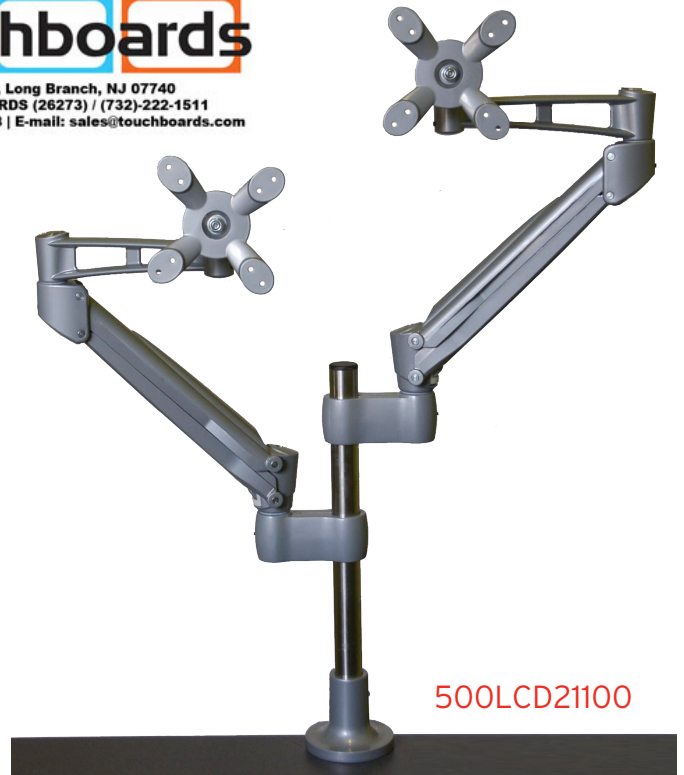

500LCD21100



500LCD23100

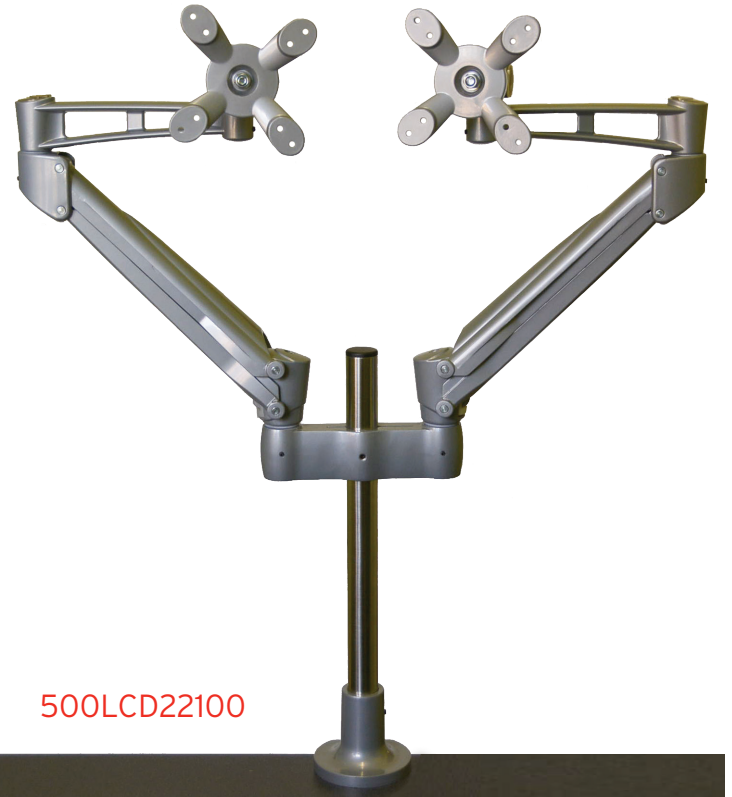

500LCD22100

## Flota Series Monitor Arms

**500LCDXXXXX**

Richelieu ERGO introduces the  
Flota monitor arm.  
The New standard!!

- Manufactured out of steel and aluminium the Flota is a sturdy monitor arm.
- The combination of the free floating arm and the pole adjustment make the Flota series ideal for all applications.
- Clamp & grommet mount included
- 75 & 100mm Vesa mount included

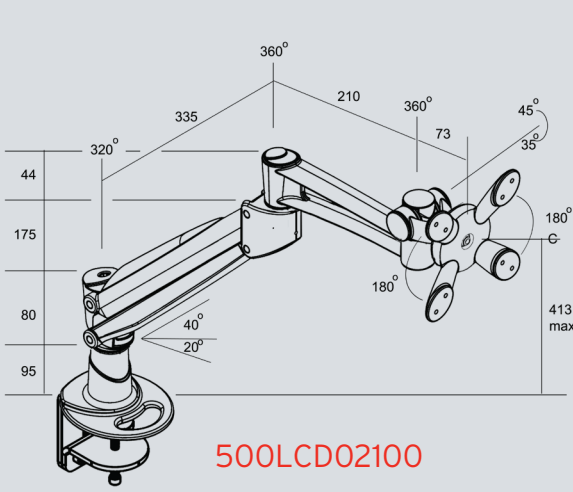

500LCD02100

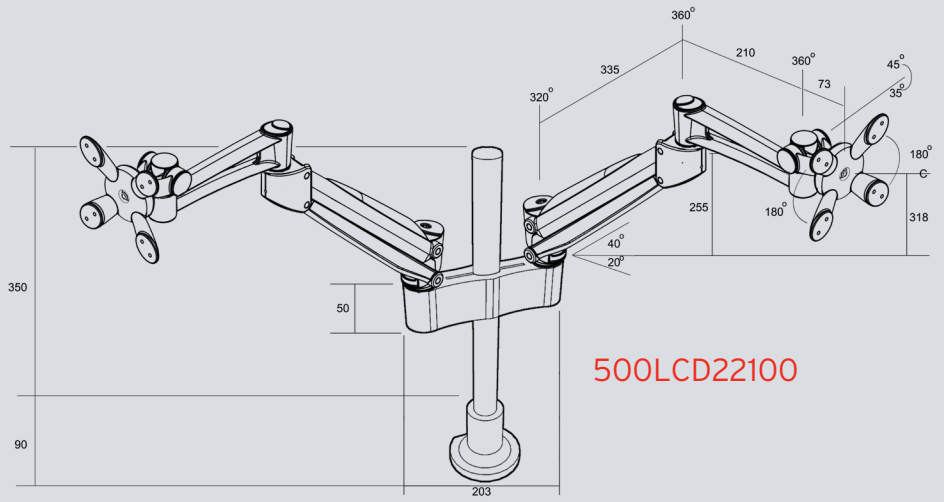

500LCD22100

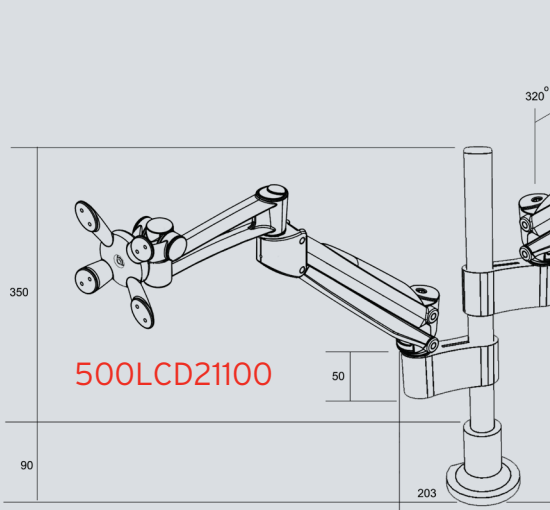

500LCD21100

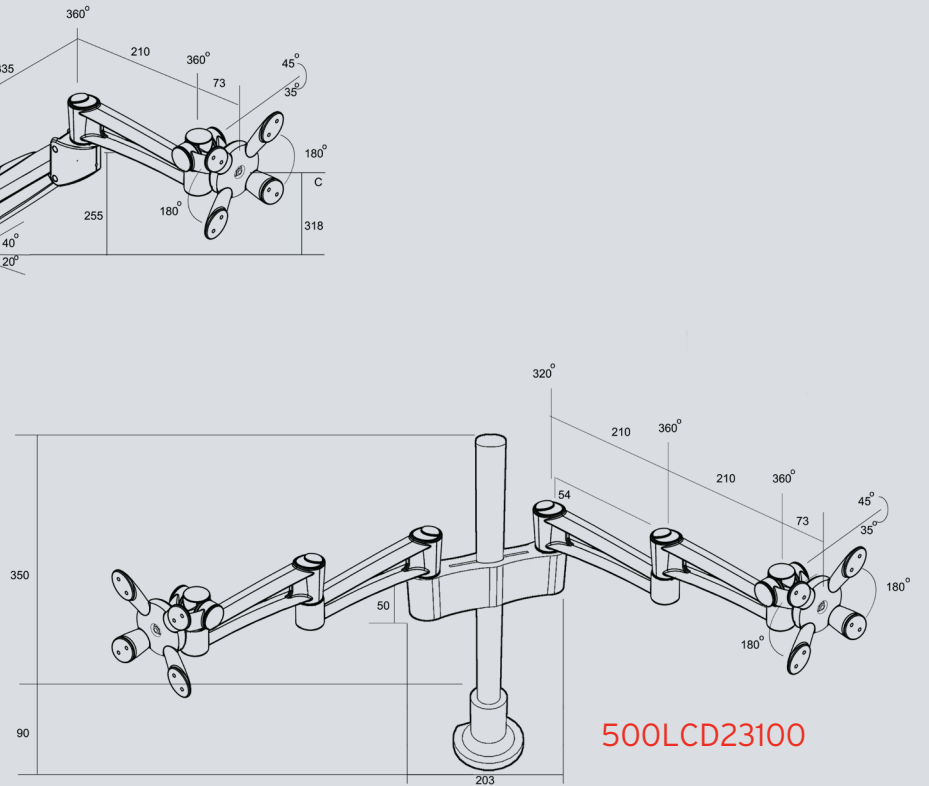

500LCD23100

Model	LCD Size	Weight Range	Rotation	Vertical Range	Maximum Spread
500LCD02100	18"- 28"	4-8 Kg – 9-17 lb	360°	50 cm – 19.5"	NA
500LCD21100	18"- 28"	8-9 kg – 17-20 lb	360°	35 cm – 13.5"	105 cm – 41.25"
500LCD22100	18"- 28"	8-9 kg – 17-20 lb	360°	35 cm – 13.5"	55 cm – 21.5"
500LCD23100	18"- 28"	4-8 kg – 9-17 lb	360°	35 cm – 13.5"	119 cm – 47."



☎ 1-866-440-0448

ergoinfo@richelieu.com

www.richelieuergo.com