

RIGOL

Service Guide

DSG800 Series RF Signal Generator

**Nov. 2015
RIGOL TECHNOLOGIES, INC.**

Guaranty and Declaration

Copyright

© 2015 **RIGOL** TECHNOLOGIES, INC. All Rights Reserved.

Trademark Information

RIGOL is a registered trademark of **RIGOL** TECHNOLOGIES, INC.

Publication Number

SGG02103-1110

Notices

- **RIGOL** products are covered by P.R.C. and foreign patents, issued and pending.
- **RIGOL** reserves the right to modify or change parts of or all the specifications and pricing policies at the company's sole decision.
- Information in this publication replaces all previously released materials.
- Information in this publication is subject to change without notice.
- **RIGOL** shall not be liable for either incidental or consequential losses in connection with the furnishing, use or performance of this manual as well as any information contained.
- Any part of this document is forbidden to be copied, photocopied or rearranged without prior written approval of **RIGOL**.

Product Certification

RIGOL guarantees that this product conforms to the national and industrial standards in China as well as the ISO9001:2008 standard and the ISO14001:2004 standard. Other international standard conformance certifications are in progress.

Contact Us

If you have any problem or requirement when using our products or this manual, please contact **RIGOL**.

E-mail: service@rigol.com

Website: www.rigol.com

Safety Requirement

General Safety Summary

Please review the following safety precautions carefully before putting the instrument into operation so as to avoid any personal injury or damage to the instrument and any product connected to it. To prevent potential hazards, please follow the instructions specified in this manual to use the instrument properly.

Use Proper Power Cord.

Only the exclusive power cord designed for the instrument and authorized for use within the local country could be used.

Ground the Instrument.

The instrument is grounded through the Protective Earth lead of the power cord. To avoid electric shock, connect the earth terminal of the power cord to the Protective Earth terminal before connecting any input or output terminals.

Connect the Probe Correctly.

If a probe is used, do not connect the ground lead to high voltage since it has isobaric electric potential as the ground.

Observe All Terminal Ratings.

To avoid fire or shock hazard, observe all ratings and markers on the instrument and check your manual for more information about ratings before connecting the instrument.

Use Proper Overvoltage Protection.

Ensure that no overvoltage (such as that caused by a bolt of lightning) can reach the product. Otherwise, the operator might be exposed to the danger of an electric shock.

Do Not Operate Without Covers.

Do not operate the instrument with covers or panels removed.

Do Not Insert Anything Into the Air Outlet.

Do not insert anything into the air outlet to avoid damage to the instrument.

Use Proper Fuse.

Please use the specified fuses.

Avoid Circuit or Wire Exposure.

Do not touch exposed junctions and components when the unit is powered on.

Do Not Operate With Suspected Failures.

If you suspect damage occurs to the instrument, have it inspected by **RIGOL** authorized personnel before further operations. Any maintenance, adjustment or replacement especially to circuits or accessories must be performed by **RIGOL** authorized personnel.

Provide Adequate Ventilation.

Inadequate ventilation may cause an increase of temperature in the instrument, which would cause damage to the instrument. So please keep the instrument well ventilated and inspect the air outlet and the fan regularly.

Do Not Operate in Wet Conditions.

To avoid short circuit inside the instrument or electric shock, never operate the instrument in a humid environment.

Do Not Operate in an Explosive Atmosphere.

To avoid personal injuries or damage to the instrument, never operate the instrument in an explosive atmosphere.

Keep Instrument Surfaces Clean and Dry.

To avoid dust or moisture from affecting the performance of the instrument, keep the surfaces of the instrument clean and dry.

Prevent Electrostatic Impact.

Operate the instrument in an electrostatic discharge protective environment to avoid damage induced by static discharges. Always ground both the internal and external conductors of cables to release static before making connections.

Use the Battery Properly.

Do not expose the battery (if available) to high temperature or fire. Keep it out of the reach of children. Improper change of a battery (lithium battery) may cause an explosion. Use the **RIGOL** specified battery only.

Handle with Caution.

Please handle with care during transportation to avoid damage to keys, knobs, interfaces and other parts on the panels.

Safety Notices and Symbols

Safety Notices in this Manual:



WARNING

Indicates a potentially hazardous situation or practice which, if not avoided, will result in serious injury or death.



CAUTION

Indicates a potentially hazardous situation or practice which, if not avoided, could result in damage to the product or loss of important data.

Safety Terms on the Product:

DANGER It calls attention to an operation, if not correctly performed, could result in injury or hazard immediately.

WARNING It calls attention to an operation, if not correctly performed, could result in potential injury or hazard.

CAUTION It calls attention to an operation, if not correctly performed, could result in damage to the product or other devices connected to the product.

Safety Symbols on the Product:



Hazardous
Voltage



Safety
Warning



Protective
Earth
Terminal



Chassis
Ground



Test
Ground

Allgemeine Sicherheits Informationen

Überprüfen Sie die folgenden Sicherheitshinweise sorgfältig um Personenschäden oder Schäden am Gerät und an damit verbundenen weiteren Geräten zu vermeiden. Zur Vermeidung von Gefahren, nutzen Sie bitte das Gerät nur so, wie in diesem Handbuche angegeben.

Um Feuer oder Verletzungen zu vermeiden, verwenden Sie ein ordnungsgemäßes Netzkabel.

Verwenden Sie für dieses Gerät nur das für ihr Land zugelassene und genehmigte Netzkabel.

Erden des Gerätes.

Das Gerät ist durch den Schutzleiter im Netzkabel geerdet. Um Gefahren durch elektrischen Schlag zu vermeiden, ist es unerlässlich, die Erdung durchzuführen. Erst dann dürfen weitere Ein- oder Ausgänge verbunden werden.

Anschluss eines Tastkopfes.

Die Erdungsklemmen der Sonden sind auf dem gleichen Spannungspegel des Instruments geerdet. Schließen Sie die Erdungsklemmen an keine hohe Spannung an.

Beachten Sie alle Anschlüsse.

Zur Vermeidung von Feuer oder Stromschlag, beachten Sie alle Bemerkungen und Markierungen auf dem Instrument. Befolgen Sie die Bedienungsanleitung für weitere Informationen, bevor Sie weitere Anschlüsse an das Instrument legen.

Verwenden Sie einen geeigneten Überspannungsschutz.

Stellen Sie sicher, daß keinerlei Überspannung (wie z.B. durch Gewitter verursacht) das Gerät erreichen kann. Andernfalls besteht für den Anwender die Gefahr eines Stromschlages.

Nicht ohne Abdeckung einschalten.

Betreiben Sie das Gerät nicht mit entfernten Gehäuse-Abdeckungen.

Betreiben Sie das Gerät nicht geöffnet.

Der Betrieb mit offenen oder entfernten Gehäuseteilen ist nicht zulässig. Nichts in entsprechende Öffnungen stecken (Lüfter z.B.)

Passende Sicherung verwenden.

Setzen Sie nur die spezifikationsgemäßen Sicherungen ein.

Vermeiden Sie ungeschützte Verbindungen.

Berühren Sie keine unisolierten Verbindungen oder Baugruppen, während das Gerät in Betrieb ist.

Betreiben Sie das Gerät nicht im Fehlerfall.

Wenn Sie am Gerät einen Defekt vermuten, sorgen Sie dafür, bevor Sie das Gerät wieder betreiben, dass eine Untersuchung durch **RIGOL** autorisiertem Personal durchgeführt wird. Jedwede Wartung, Einstellarbeiten oder Austausch von Teilen am Gerät, sowie am Zubehör dürfen nur von **RIGOL** autorisiertem Personal durchgeführt werden.

Belüftung sicherstellen.

Unzureichende Belüftung kann zu Temperaturanstiegen und somit zu thermischen Schäden am Gerät führen. Stellen Sie deswegen die Belüftung sicher und kontrollieren regelmäßig Lüfter und Belüftungsöffnungen.

Nicht in feuchter Umgebung betreiben.

Zur Vermeidung von Kurzschluß im Geräteinneren und Stromschlag betreiben Sie das Gerät bitte

niemals in feuchter Umgebung.

Nicht in explosiver Atmosphäre betreiben.

Zur Vermeidung von Personen- und Sachschäden ist es unumgänglich, das Gerät ausschließlich fernab jedweder explosiven Atmosphäre zu betreiben.

Geräteoberflächen sauber und trocken halten.

Um den Einfluß von Staub und Feuchtigkeit aus der Luft auszuschließen, halten Sie bitte die Geräteoberflächen sauber und trocken.

Schutz gegen elektrostatische Entladung (ESD).

Sorgen Sie für eine elektrostatisch geschützte Umgebung, um somit Schäden und Funktionsstörungen durch ESD zu vermeiden. Erden Sie vor dem Anschluß immer Innen- und Außenleiter der Verbindungsleitung, um statische Aufladung zu entladen.

Die richtige Verwendung des Akkus.

Wenn eine Batterie verwendet wird, vermeiden Sie hohe Temperaturen bzw. Feuer ausgesetzt werden. Bewahren Sie es außerhalb der Reichweite von Kindern auf. Unsachgemäße Änderung der Batterie (Anmerkung: Lithium-Batterie) kann zu einer Explosion führen. Verwenden Sie nur von **RIGOL** angegebenen Akkus.

Sicherer Transport.

Transportieren Sie das Gerät sorgfältig (Verpackung!), um Schäden an Bedienelementen, Anschlüssen und anderen Teilen zu vermeiden.

Sicherheits Begriffe und Symbole

Begriffe in diesem Guide:



WARNING

Die Kennzeichnung WARNING beschreibt Gefahrenquellen die leibliche Schäden oder den Tod von Personen zur Folge haben können.



CAUTION

Die Kennzeichnung Caution (Vorsicht) beschreibt Gefahrenquellen die Schäden am Gerät hervorrufen können.

Begriffe auf dem Produkt:

- DANGER** weist auf eine Verletzung oder Gefährdung hin, die sofort geschehen kann.
WARNING weist auf eine Verletzung oder Gefährdung hin, die möglicherweise nicht sofort geschehen.
CAUTION weist auf eine Verletzung oder Gefährdung hin und bedeutet, dass eine mögliche Beschädigung des Instruments oder anderer Gegenstände auftreten kann.

Symbole auf dem Produkt:



Gefährliche
Spannung



Sicherheits-
Hinweis



Schutz-erde



Gehäusemasse



Erde

Document Overview

Format Conventions in this Manual

1. Key:

The key at the front panel is denoted by the format of "Text Box + Key Name (Bold)" in the manual. For example, **FREQ** denotes the **FREQ** key.

2. Menu:

The menu is denoted by the format of "Character Shading + Menu Word (Bold)" in the manual. For example, **LF** denotes the submenu low frequency under **FREQ**.

3. Connector:

The connector on the front or rear panel is denoted by the format of "Square Brackets + Connector Name (Bold)" in the manual. For example, **[RF OUTPUT 50Ω]**.

4. Operation Step:

The operation for the next step is denoted by an arrow "→" in the manual. For example, **FREQ** → **LF** denotes that you first press **FREQ** on the front panel and then press **LF**.

Manuals of this Product

The manuals of this product include Quick Guide, User's Guide, Programming Guide, Data Sheet, Service Guide, etc. The latest versions of the manuals can be downloaded from www.rigol.com.

Contents

Guaranty and Declaration	I
Safety Requirement	II
General Safety Summary	II
Safety Notices and Symbols	IV
Allgemeine Sicherheits Informationen	V
Sicherheits Begriffe und Symbole	VII
Document Overview	VIII
Chapter 1 Disassembly and Assembly	1-1
Notices to Disassembly and Assembly	1-1
Exploded View Drawing of the Instrument	1-2
Disassemble the Handle	1-4
Disassemble Rear Support Legs	1-5
Disassemble the Metal Enclosure	1-6
Disassemble BNC-MCX Feedthroughs	1-7
Disassemble the Power Module	1-8
Disassemble Front Protective Covers	1-9
Disassemble the Front Panel Assembly	1-10
Disassemble the Control Board	1-11
Disassemble the Front Panel Cover, Keypads and the Knob	1-12
Disassemble the LCD	1-13
Disassemble the Keypad Boards	1-14
Disassemble the OCXO Module	1-15
Disassemble the RF Module	1-16
Disassemble the Fan	1-17
Assembly Procedures	1-18
Chapter 2 Troubleshooting&Maintenance	2-1
Troubleshooting	2-1
Maintenance	2-4
System Maintenance	2-4
Warranty	2-4
Care and Cleaning	2-5
Environmental Considerations	2-5
Chapter 3 Appendix	3-1
Appendix A: Error Codes and Explanations	3-1
Command Errors	3-1
Execution Errors	3-3
Device-specific Errors	3-5
Query Errors	3-7
Appendix B: Software Update	3-8

Chapter 1 Disassembly and Assembly

Notices to Disassembly and Assembly

Notices:

- Do not disassemble the instrument unless for working requirement.
- Only authorized personnel are allowed to disassemble the instrument.
- Cut off the power supply before disassembling the instrument.
- Please wear anti-static wrist strap or make other anti-static precaution when disassembling the instrument.
- Please use proper tools and follow the correct steps.
- Take care not to deform the metal structure or get hurt when disassembling the metal structures.
- To avoid causing damage to the instrument due to improper operation and to save your time, we recommend you to follow the disassembly steps and methods in this guide manual.

Required Tools:

- Phillips screwdriver T20/T10
- BNC socket wrench



WARNING

Ensure that the power supply is cut off before disassembling the instrument. Only well-trained professional personnel or qualified personnel are allowed to disassemble the instrument.

Exploded View Drawing of the Instrument

You need to get a basic understanding of the main parts of the instrument before disassembling and assembling the instrument. When disassembling or assembling the instrument, please follow the procedures and avoid scratching the part surface. This manual mainly introduces the disassembly and assembly methods of DSG800 series RF signal generator. The exploded view drawing for DSG800 (with OCXO module) is as shown in Figure 1-1.

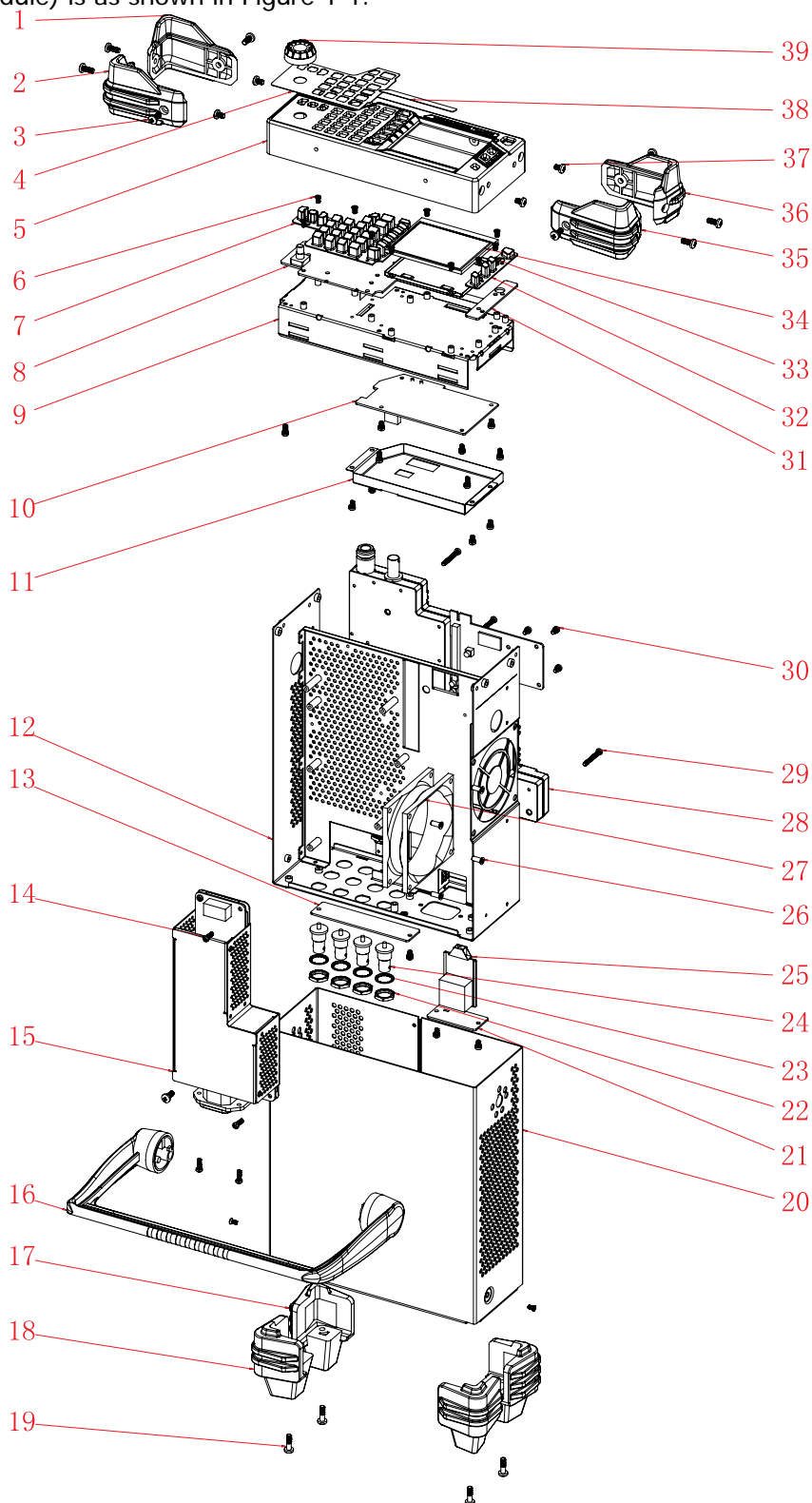

Figure 1-1 DSG800 Exploded View Drawing

Table 1-1 Replacement Parts List

No.	Part No.	Qty.	Name/Description
1	2010001564	1	Front Protective Cover (Bottom Right)
2	2010001562	1	Front Protective Cover (Top Right)
3	1020000569	9	M4*10 Torx Pan Head Screw
4	1020003338	1	Controls Film
5	2010002859	1	Front Panel
6	1020000579	12	M3*6 Torx Flat Countersunk Head Screw
7	1020003310	1	Main Keypad
8	2010003244	1	Main Keypad Board
9	1020003315	1	Front Metal Cover
10	2010003243	1	Control Board
11	1020003320	1	Shielding Cover
12	1020003316	1	Metal Chassis
13	1020003318	1	IQ Plate
14	1020000550	4	M3*10 Torx Pan Head Screw
15	2010003649	1	Power Box
16	2010000346	1	Handle
17	2010001566	2	Rear Support Leg (Bottom)
18	2010001560	2	Rear Support Leg (Top)
19	1020001048	4	M4*14 Torx Pan Head Screw
20	1020003317	1	Metal Enclosure
21	1020001834	1	OCXO Plate
22	1020000619	4	BNC Nut
23	1020000648	4	BNC Washer
24	1010004911	4	BNC-MCX Feedthrough
25	2010003300	1	OCXO Module
26	1020003198	4	PTF5*10 Torx Flat Countersunk Head Self-tapping Screw
27	1020003307	1	Fan
28	2010003648	1	RF Module
29	1020002124	5	M3*25 Torx Pan Head Combination Screw
30	1020000571	22	M3*6 Torx Pan Head Combination Screw
31	2010003245	1	Side Keypad Board
32	1020003311	1	Side Keypad
33	1020003319	1	Screen Bezel Mounting Frame
34	2010003560	1	LCD
35	2010001563	1	Front Protective Cover (Top Left)
36	2010001561	1	Front Protective Cover (Bottom Left)
37	1020000552	4	M4*6 Torx Pan Head Screw
38	1020003363	1	Front Label
39	2010001542	1	Knob

The recommended disassembly procedures are as follows:

Disassemble the Handle → Disassemble Rear Support Legs → Disassemble the Metal Enclosure → Disassemble BNC-MCX Feedthroughs → Disassemble the Power Module → Disassemble Front Protective Covers → Disassemble the Front Panel Assembly → Disassemble the Control Board → Disassemble the Front Panel Cover, Keypads and the Knob → Disassemble the LCD → Disassemble the Keypad Boards → Disassemble the OCXO Module → Disassemble the RF Module → Disassemble the Fan.

Disassemble the Handle

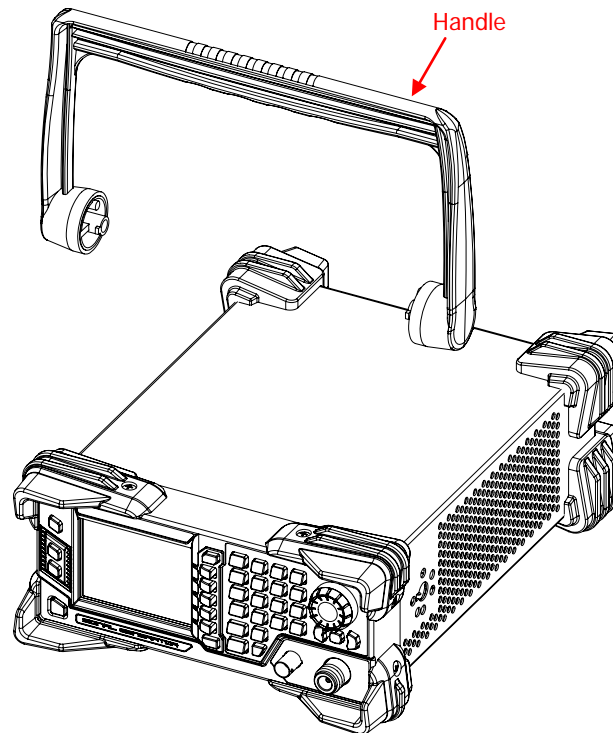

Figure 1-2 Disassemble the Handle

Part Description:

- ① 1 handle.

Disassembly Step:

Rotate the handle upright and pull out from the sides of the instrument to remove the handle.

Note: Before assembling the handle, check whether the metal enclosure is correctly installed.

Disassemble Rear Support Legs

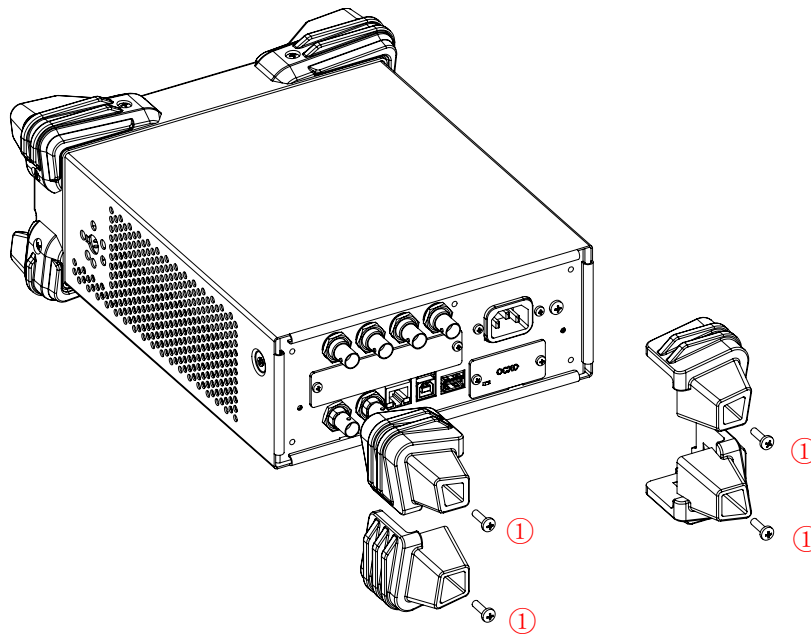

Figure 1-3 Disassemble Rear Support Legs

Part Description:

- ① 4 screws (M4*14 torx pan head screw, used for securing rear support legs).

Disassembly Steps:

1. Use the T20 screwdriver to remove 4 screws (①) that secure rear support legs.
2. Take off rear support legs gently.

Note: When assembling rear support legs, pay attention to the mounting position of rear support legs. The rear support leg with 2 ribs on it should be mounted at the top; whereas the rear support leg with three ribs on it should be mounted at the bottom.

Disassemble the Metal Enclosure

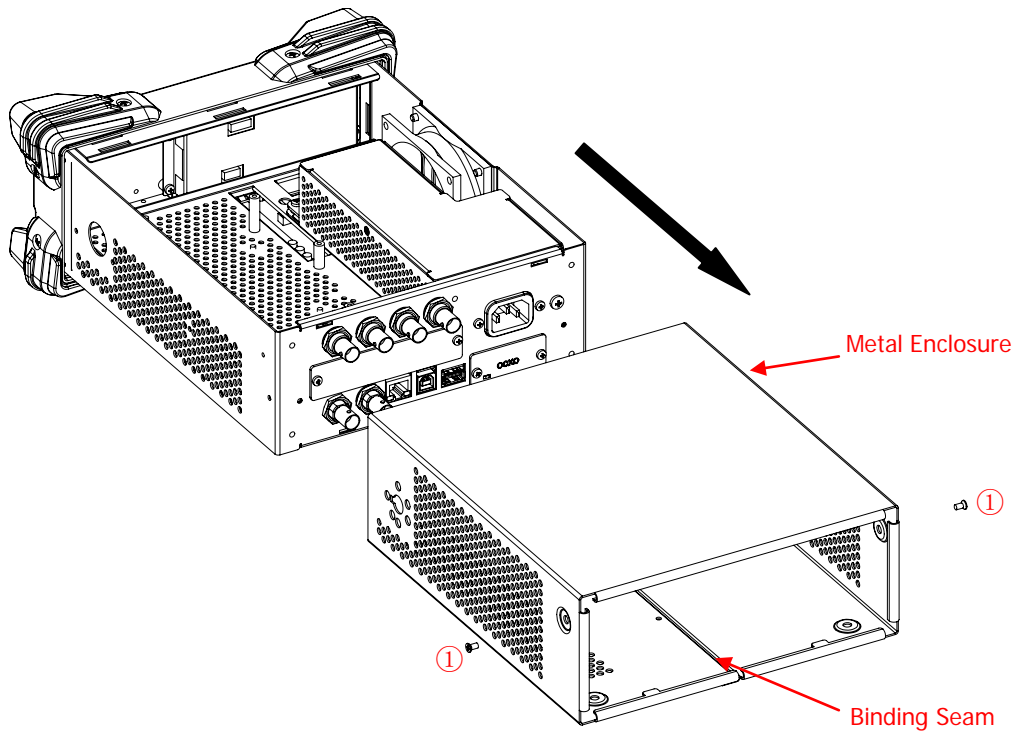

Figure 1-4 Disassemble the Metal Enclosure

Part Description:

- ① 2 screws (M3*6 torx flat countersunk head screw, used for fastening the metal enclosure to the metal chassis).
- ② 1 metal enclosure.

Disassembly Steps:

1. Use the T10 screwdriver to remove 2 screws (①) that secure the metal enclosure.
2. Take off the metal enclosure gently in the arrow direction (as shown in the figure above).

Note: When assembling the metal enclosure, the side of the metal enclosure with a binding seam should be placed downward.

Disassemble BNC-MCX Feedthroughs

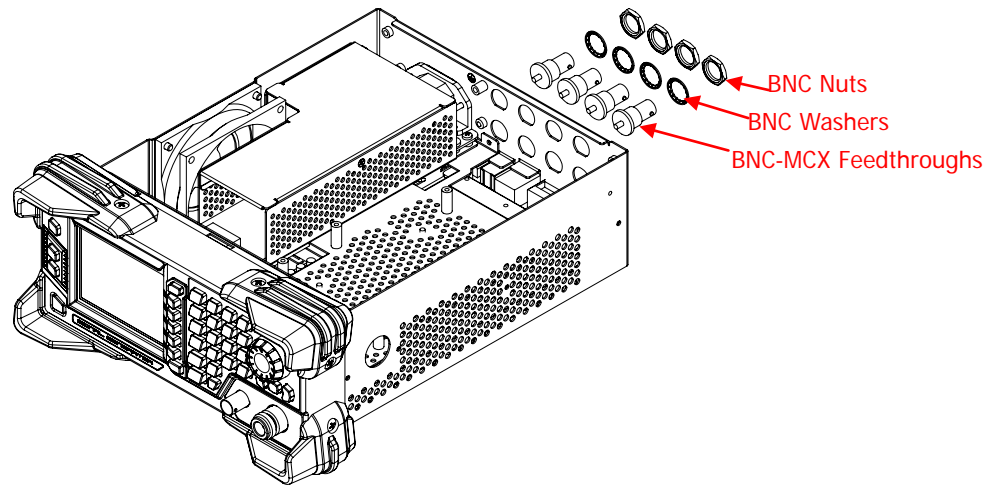

Figure 1-5 Disassemble BNC-MCX Feedthroughs

Part Description:

- ① 4 BNC nuts for fastening BNC-MCX feedthroughs.
- ② 4 BNC washers for fastening BNC-MCX feedthroughs.

Disassembly Steps:

1. Use the BNC socket wrench to remove 4 BNC nuts (①) and 4 BNC washers (②) that fasten BNC-MCX feedthroughs.
2. Remove BNC-MCX feedthroughs gently.

Tip:

Before disassembling BNC-MCX feedthroughs, pay attention to the mounting position of each feedthrough to avoid incorrect mounting or incomplete mounting when assembling the feedthroughs.

Disassemble the Power Module

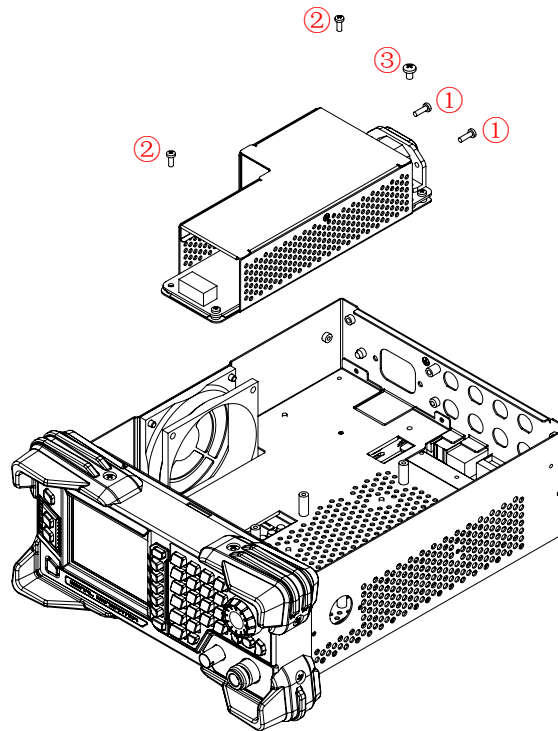

Figure 1-6 Disassemble the Power Module

Part Description:

- ① 2 screws (M3*10 torx pan head screw, used for fastening the power cord connector).
- ② 2 screws (M3*10 torx pan head screw, used for fastening the power module).
- ③ 1 screw (M4*10 torx pan head screw, used for fastening the power module).

Disassembly Steps:

1. Use the T10 screwdriver to remove 2 screws (①) that fasten the power cord connector.
2. Remove the cables that connect the power module.
3. Use the T10 screwdriver to remove 2 screws (②) that fasten the power module.
4. Use the T10 screwdriver to remove the screw (③) that fastens the power module.
5. Take out the power module gently.

Tip:

1. Before disassembling the cables on the power module, please pay attention to the connecting positions of the cables to avoid incorrect connection or incomplete connection when assembling the cables.
2. When assembling the instrument, the three screws that fasten the power module should be well grounded.

Disassemble Front Protective Covers

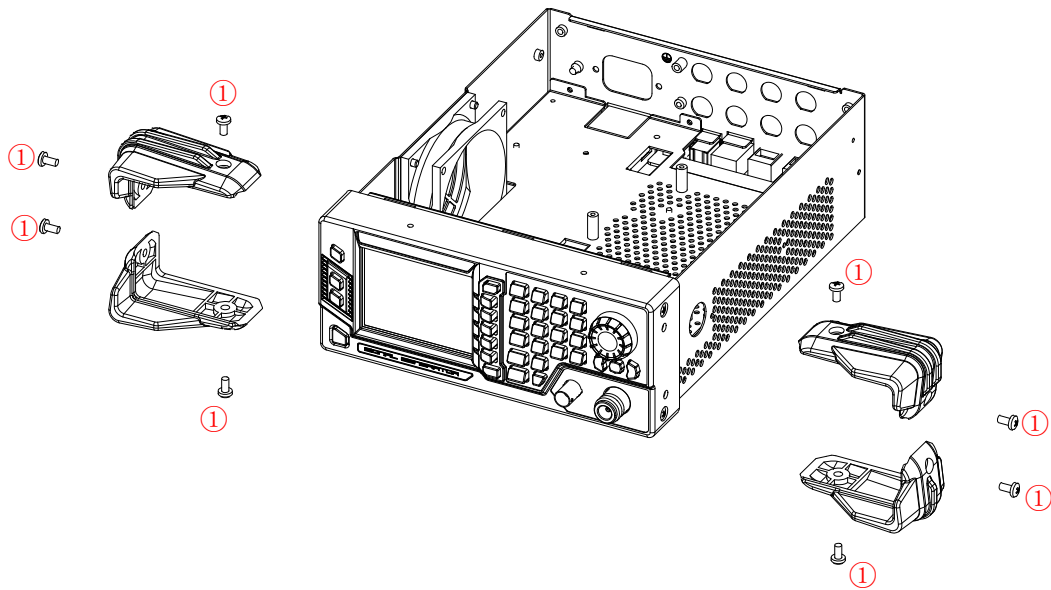

Figure 1-7 Disassemble Front Protective Covers

Part Description:

① 8 screws (M4*10 torx pan head screw, used for fastening front protective covers).

Disassembly Steps:

1. Use the T20 screwdriver to remove 8 screws (①) that fasten front protective covers.
2. Remove front protective covers gently.

Note: When assembling front protective covers, pay attention to their mounting position. The front protective cover with 2 ribs on it should be mounted at the top; whereas the front protective cover with one rib on it should be mounted at the bottom.

Disassemble the Front Panel Assembly

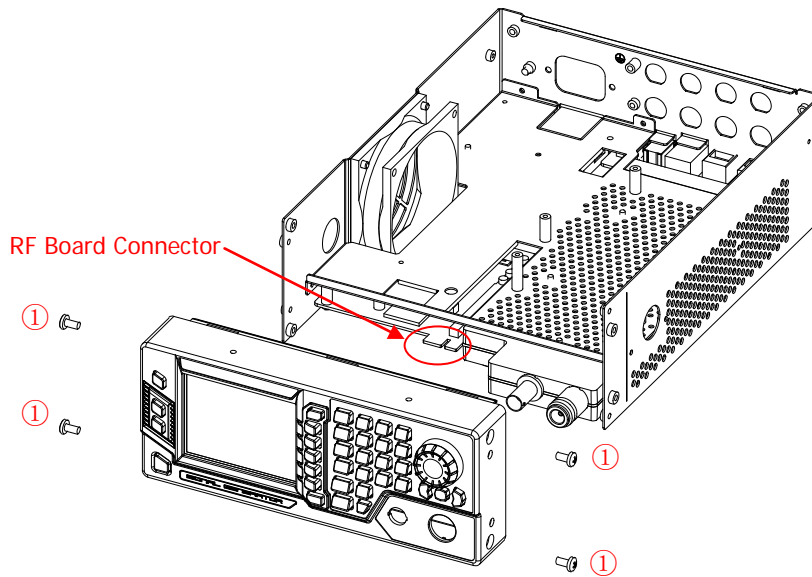

Figure 1-8 Disassemble the Front Panel Assembly

Part Description:

- ① 4 screws (M4*6 torx pan head screw, used for fastening the front panel assembly).

Disassembly Steps:

1. Use the T20 screwdriver to remove 4 screws (①) that fasten the front panel assembly.
2. Remove the front panel assembly gently.

Note: When assembling the instrument, align the RF board connector (as shown in the figure above) with the specified slot on the control board.

Disassemble the Control Board

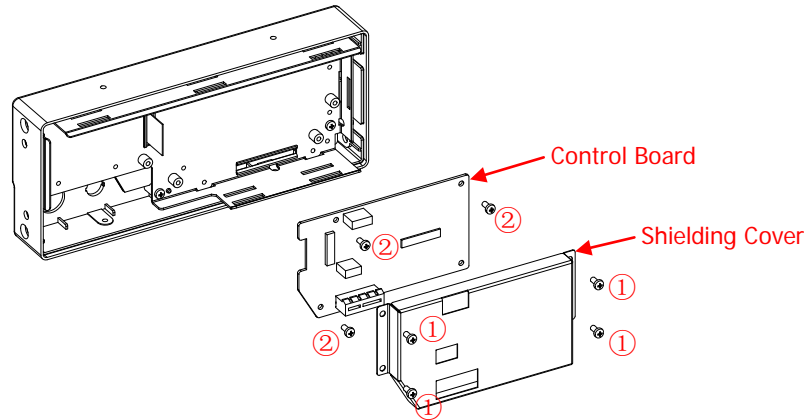

Figure 1-9 Disassemble the Control Board

Part Description:

- ① 4 screws (M3*6 torx pan head combination screw, used for fastening the shielding cover).
- ② 4 screws (M3*6 torx pan head combination screw, used for fastening the control board). Some of the screws are not marked out in the figure above and please disassemble them all.

Disassembly Steps:

1. Use the T10 screwdriver to remove 4 screws (①) that fasten the shielding cover.
2. Pull out the screen cable and keyboard cable from the corresponding slots.
3. Use the T10 screwdriver to remove 4 screws (②) that fasten the control board.
4. Remove the control board gently.

Tip:

Before disassembling the cables on the control board, pay attention to the connecting positions of the cables to avoid incorrect connection or incomplete connection when assembling the cables.

Disassemble the Front Panel Cover, Keypads and the Knob

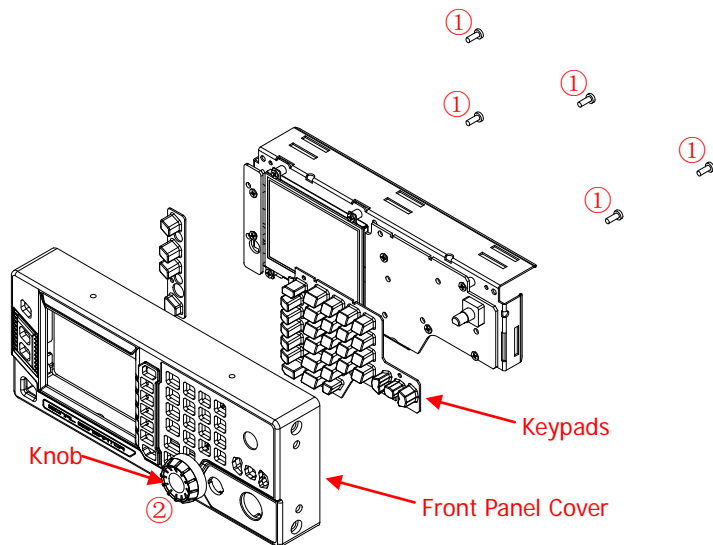

Figure 1-10 Disassemble the Front Panel Cover, Keypads and the Knob

Part Description:

- ① 5 screws (M3*6 torx pan head combination screw, used for fastening the front panel assembly).
- ② 1 knob.

Disassembly Steps:

1. Pull out the knob on the front panel slowly.
2. Use the T10 screwdriver to remove 5 screws (①) that fasten the front panel assembly.
3. Remove the front panel cover and keypads gently.

Disassemble the LCD

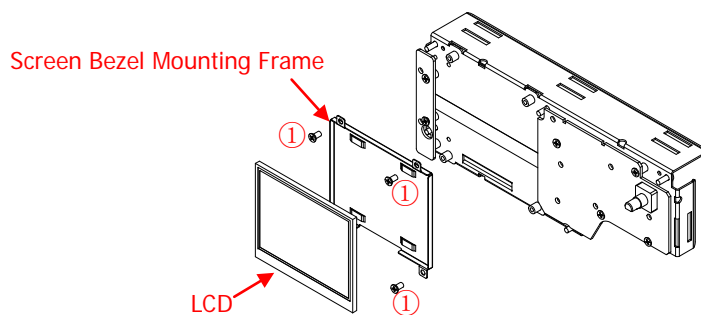

Figure 1-11 Disassemble the LCD

Part Description:

- ① 4 screws (M3*6 torx flat countersunk head screw, used for fastening the LCD assembly). Some of the screws are not marked out in the figure above and please disassemble them all.

Disassembly Steps:

1. Use the T10 screwdriver to remove 4 screws (①) that fasten the LCD assembly.
2. Take off the LCD assembly from the front metal cover gently.

Disassemble the Keypad Boards

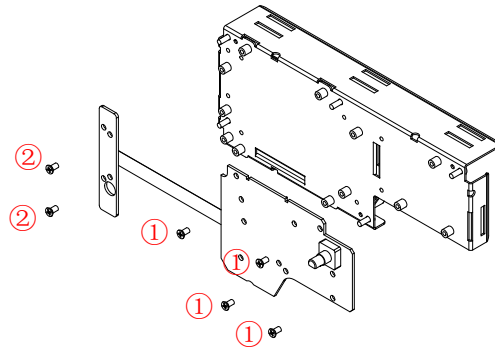

Figure 1-12 Disassemble the Keypad Boards

Part Description:

- ① 4 screws (M3*6 torx flat countersunk head screw, used for fastening the main keypad board).
- ② 2 screws (M3*6 torx flat countersunk head screw, used for fastening the side keypad board).

Disassembly Steps:

1. Use the T10 screwdriver to remove 4 screws (①) that fasten the main keypad board and 2 screws (②) that fasten the side keypad board.
2. Remove the main keypad board and the side keypad board gently.

Disassemble the OCXO Module

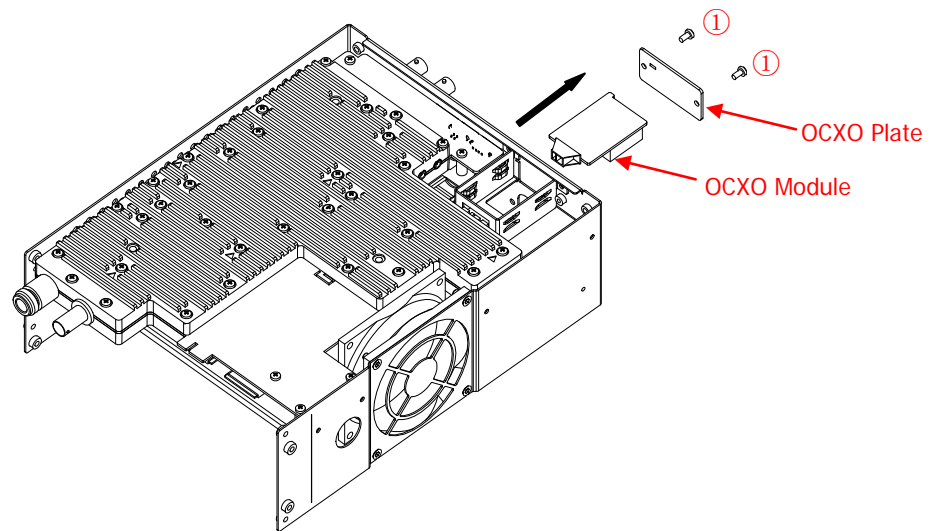

Figure 1-13 Disassemble the OCXO Module

Part Description:

- ① 2 screws (M3*6 torx pan head combination screw, used for fastening the OCXO plate).

Disassembly Steps:

1. Use the T10 screwdriver to remove 2 screws (①) that fasten the OCXO plate.
2. Remove the OCXO plate gently.
3. Take off the OCXO module in the arrow direction (as shown in the figure above).

Disassemble the RF Module

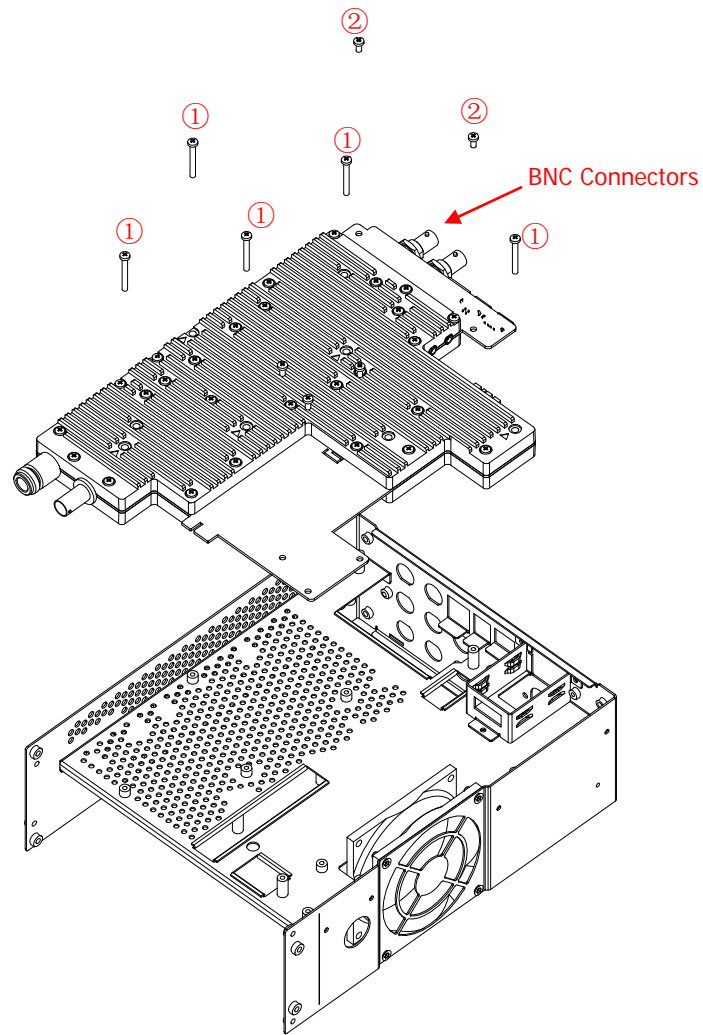

Figure 1-14 Disassemble the RF Module

Part Description:

- ① 5 screws (M3*25 torx pan head combination screw, used for fastening the RF module).
- ② 2 screws (M3*6 torx pan head combination screw, used for fastening the RF module).

Disassembly Steps:

1. Use the BNC socket wrench to remove BNC nuts and washers that fasten the BNC connectors.
2. Use the T10 screwdriver to remove 5 screws (①) and 2 screws (②) that fasten the RF module.
3. Remove the RF module from the metal chassis gently.

Tip:

Before disassembling the RF module, remove the cables on the RF module and pay attention to the connecting positions of the cables to avoid incorrect connection or incomplete connection when assembling the cables.

Disassemble the Fan

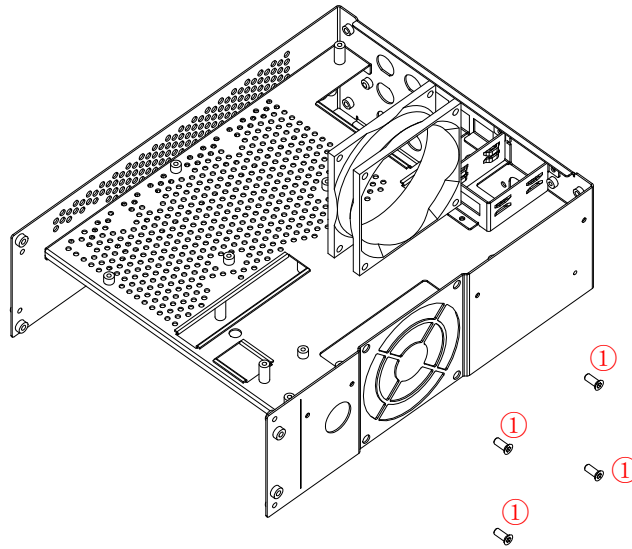

Figure 1-15 Disassemble the Fan

Part Description:

- ① 4 screws (PTF5*10 torx flat countersunk head self-tapping screw, used for fastening the fan).

Disassembly Steps:

1. Use the T10 screwdriver to remove 4 screws (①) that fasten the fan.
2. Remove the fan gently.

Tip:

Before disassembling the fan, pay attention to the installation direction of the fan to avoid incorrect connection when assembling the fan.

Assembly Procedures

The assembly procedures are simply the reversal of the disassembly procedures. Check whether the cables are correctly connected and whether all the screws are installed after completing each assembly step.

Chapter 2 Troubleshooting&Maintenance

Troubleshooting

The commonly encountered failures of DSG800 and their solutions are listed below. When you encounter those problems, please observe the following instructions to resolve them. If the problem still persists, please contact **RIGOL** and provide your instrument information to us (press **Syst** → **Information** → **System Info** to obtain information about your instrument).

1. The screen of the RF signal generator stays black/does not display anything after the instrument powers on.

- (1) Check whether the fan is running;
 - If the fan is running but the screen stays black, it indicates that the connecting wire of the screen might be loose.
 - If the fan is not running, it indicates that the instrument does not start successfully. Then, please go to Step (2).
- (2) Check whether the power cord is correctly connected and whether the instrument powers on.
- (3) Check whether the fuse is burnt out. If the fuse needs to be replaced, please contact **RIGOL**.
- (4) Restart the instrument after completing the above inspections.
- (5) If it still does not work correctly, please contact **RIGOL**.

2. The screen is too dark to be seen clearly.

- (1) Check whether the brightness of the LCD that you set is too low.
- (2) Press **Syst** → **Display** → **Brightness**, then select the desired numeric key and then press **Enter** to set the brightness value. Or you can Press **Syst** → **Display** → **Brightness**, then use the knob to adjust the LCD brightness of the RF signal generator.

3. The RF signal generator is locked.

- (1) Check whether the RF signal generator is in remote control mode. In remote control, **Rmt** is displayed in the status bar of the user interface. In this situation, press **ESC** to exit the remote control mode and unlock the front panel.
- (2) Check whether the RF signal generator is in local mode with the screen being locked. When the screen is locked, you cannot operate on the front panel. In this situation, press **ESC** to unlock the screen and exit the locking state.
- (3) If progress bar is displayed on the screen of the RF signal generator, it indicates that some operation is in progress. For example, when saving a file, the progress bar displayed indicates that the save operation is in progress. During the operation, the front panel is locked.
- (4) You can also press **Preset** or restart the RF signal generator to unlock the instrument.

4. The setting is correct but the waveform output is incorrect.

- (1) No RF output
 - Check whether the signal connecting cable is tightly connected to the specified **[RF OUTPUT 50Ω]** connector.
 - Check whether there is internal damage to the connecting cable.
 - Check whether the connecting cable is tightly connected to the test instrument.
 - Check whether the **RF/on** key is illuminated. If not, press this key again. When the key is illuminated, the RF label in the function status area in the user interface is highlighted and the RF output is turned on correctly.
 - Check whether the output amplitude of the RF signal is too small. If the problem exists, adjust the output amplitude properly.

- (2) No modulation at the RF output
 - Check whether the signal connecting cable is tightly connected to the specified **[RF OUTPUT 50Ω]** connector.
 - Check whether there is internal damage to the connecting cable.
 - Check whether the connecting cable is tightly connected to the test instrument.
 - Check whether the **Mod/on** and **RF/on** key are both illuminated. Check whether the modulation type that you need is enabled. (Press **MOD** to select the modulation type you need, and open its submenu to set **Switch** to be "on".)
 - Check whether the modulation parameter settings are correct. If not proper, adjust the parameters appropriately.
 - If the external modulation source is used, ensure that the external source is correctly connected and signals can be output. Besides, ensure that the external source works within the specified range of the RF signal generator.

5. The sweep is abnormal.

- (1) The sweep appears stalled.

The sweep progress bar is displayed in the frequency area/amplitude area in the user interface. This indicates that the sweep is in progress. If the sweep appears to stall, please check the following:

 - Check whether one of the sweep types is selected. Press **SWEEP** → **Sweep** to select "Freq", "Level" or "Freq & Level".
 - If the sweep is in single mode, press **Single** to meet the trigger condition and the instrument performs a sweep.
 - If you did not set the trigger mode to Auto, you can press **SWEEP** → **Trig Mode** → **Auto** to check whether the sweep is performed automatically.
 - If you did not set the point trigger mode to Auto, press **SWEEP** → **Point Trig** → **Auto** to check whether the sweep is performed automatically.
 - Check whether the dwell time is set to a value that was too slow or too fast to see.
 - Ensure that at least two points are set in the step sweep or list sweep.
- (2) The dwell time of list sweep is incorrect.
 - Press **SWEEP** → **List Swp** to enter the sweep list menu.
 - Press **Load** to load the desired sweep list and press **View** to check whether the dwell time in the sweep list is correct.
 - If the dwell time is incorrect, re-edit the sweep list and load it to the instrument. If the dwell time is correct, go to the next step.
 - Press **SWEEP** → **Type** to make sure that "List" sweep is selected.

If "Step" sweep is currently selected, the RF signal generator sweeps according to the dwell time of the step sweep.
- (3) The list sweep information recalled from the register is lost.
 - The list sweep information is not stored as part of the instrument state information in an instrument state register.
 - The RF signal generator can only use the list currently loaded for sweep.
- (4) In list or step sweep, the amplitude does not change
 - Ensure that **Sweep** under the **SWEEP** menu is set to "Level" or "Freq & Level".
 - If **Sweep** is currently set to "Freq", the amplitude will not change.

6. The USB storage device cannot be recognized.

- (1) Check whether the USB storage device can work normally when being connected to other instrument or a PC.
- (2) Ensure that you use a USB flash storage device. This instrument does not support hardware USB storage device.
- (3) Restart the instrument and insert the USB storage device to check whether it can work normally.
- (4) If the USB storage device still cannot be used normally, please contact **RIGOL**.

7. When you press the key, it does not respond or the key is stuck.

- (1) After starting the instrument, check whether all the keys are irresponsive.
- (2) Press **Syst** → **Self-Test** → **Key Test** to enter the keyboard test interface. Press all the function keys on the front panel sequentially and check whether some key is irresponsive or stuck.
- (3) If the above failures occur, the connecting wire of the keypad board might be loose or the keypad board is damaged. Please do not disassemble the instrument and contact **RIGOL**.

8. The instrument does not pass the performance specifications test.

- (1) Check whether the RF signal generator is within the calibration period (1 year).
- (2) Check whether the RF signal generator is warmed up for at least 40 minutes before being tested.
- (3) Check whether the RF signal generator is placed in an environment with a specified temperature.
- (4) Check whether the test is performed in a highly magnetic environment.
- (5) Check whether the power supply for the RF signal generator and the test system have strong interference.
- (6) Check whether the performance of the test device meets the requirements.
- (7) Check whether the test device is within the calibration period.
- (8) Check whether the test device is working under the required conditions specified in the manual.
- (9) Check whether all the connections are tight.
- (10) Check whether there is internal damage to all cables.
- (11) Ensure that the operations conform to the settings and procedures specified in the performance verification guide.
- (12) Check whether there is an error in calculation.
- (13) Get a correct understanding of the definitions of "Typical Value" and "Nominal Value".
 - Typical Value: indicates the performance specifications of the product under the specified conditions.
 - Nominal Value: indicates the approximate quantity of the product in application.

Maintenance

System Maintenance

In order to ensure the performance and prolong the service life of the instrument, please follow the recommendations below.

1. Get a full understanding of the instrument performance and its basic operating method before using it.
2. In order to ensure the measurement accuracy and prolong the service life of the instrument, protect the instrument against dust, shock, moisture, magnetic field and static electricity. Moreover, the instrument should not be exposed to sunlight for long periods of time.
3. Do not operate the instrument with functional failures. If a certain function of the instrument fails to work normally during its operating period, locate the problem and resolve it, then you can continue to operate the instrument. Besides, regular test and calibration should be performed to ensure the accuracy of its performance.
4. Arrange the instrument properly after you complete the operation.
5. Keep instrument accessories properly for future use.

Warranty

RIGOL warrants that the product mainframe and product accessories will be free from defects in materials and workmanship within the warranty period.

If a product proves defective within the respective period, **RIGOL** guarantees free replacement or repair of any defective products within a reasonable period of time. To get repair service, please contact with your nearest **RIGOL** sales or service office.

There is no other warranty, expressed or implied, except such as is expressly set forth herein or other applicable warranty card. There is no implied warranty of merchantability or fitness for a particular purpose. Under no circumstances shall **RIGOL** be liable for any consequential, indirect, ensuing or special damages for any breach of warranty in any case.

Care and Cleaning

Care

Do not store or leave the instrument where it may be exposed to direct sunlight for long periods of time.

Cleaning

Clean the instrument regularly according to its operating conditions.

1. Disconnect the instrument from all power sources.
2. Clean the external surfaces of the instrument with a soft cloth dampened with mild detergent or water. When cleaning the LCD, take care to avoid scarifying it.



CAUTION

To avoid damage to the instrument, do not expose it to caustic liquids.



WARNING

To avoid short-circuit resulting from moisture or personal injuries, ensure that the instrument is completely dry before connecting it to the power supply.

Environmental Considerations

The following symbol indicates that this product complies with the WEEE Directive 2002/96/EC.



Product End-of-Life Handling

The equipment may contain substances that could be harmful to the environment or human health. In order to avoid the release of such substances into the environment and harm to human health, we recommend you to recycle this product appropriately to ensure that most materials are reused or recycled properly. Please contact your local authorities for disposal or recycling information.

Chapter 3 Appendix

Appendix A: Error Codes and Explanations

Command Errors

NO.	Content
-100	Command error Indicates a syntax error, which means no more detailed error information could be detected. This code indicates that only Command Error defined in IEEE 488.2,11.5.1.1.4 has been found.
-101	Invalid character Indicates that the syntax contains an invalid character. For example, the command header contains an ampersand (SETUP&). This error might be used in place of errors -112, -115, -124 and perhaps some others.
-102	Syntax error Indicates that a command or data type cannot be recognized. For example, the device receives a string that was not supported by the device.
-103	Incorrect separator Indicates that the parser was expecting a separator but received an illegal character. For example, the semicolon in a programming message was omitted: *EMC 1:CH1:VOLTS 5.
-104	Data type error Indicates that the parser encountered a data not allowed. For example, numeric or string data was expected but block data was encountered.
-105	GET not allowed Indicates that a Group Execute Trigger (GET) was contained in a programming message (refer to IEEE 488.2, 7.7).
-106	Parameter not allowed Indicates that parameters not allowed were received than expected for the command header. For example, the *EMC common command only accepts a single parameter; therefore, *EMC 0, 1 is not allowed.
-107	Parameter lost Indicates that fewer parameters were received than required for the command header. For example, *EMC common command requires one parameter. Therefore, *EMC is not allowed.
-108	Command header error Indicates that an error was found in the command header. This error is generated when no more specific information is available, such as error types -109 through -113.
-109	Command header separator error Indicates that an illegal command header separator was found when the device is parsing the command header. For example, *GMC"MACRO" is found that a space is omitted in the command header.
-110	Command header character is too long Indicates that command header contains more than 12 characters (refer to IEEE 488.2, 7.6.1.4.1).
-111	Undefined command header Indicates that the command header is syntactically correct, but it is undefined for the device. For example, *XYZ is not defined for any device.
-112	Command header suffix exceeds range Indicates that a numeric suffix value was attached to a programming mnemonic, making the command header invalid.

- 113 Incorrect number of parameters**
Indicates that the number of parameters received does not correspond to the number of parameters expected. This is typically due to an inconsistency with the number of the instrument in the selected group (refer to INSTRUMENT:DEFINE:GROUP).
- 114 Numeric data error**
This error, as well as errors from -115 to -118, is generated when the device is parsing a data element. The numeric data indicates that a non-decimal number is contained in the numeric representation area. This error is generated when no more specific information is available.
- 115 Invalid character in the numeric value**
Indicates that an invalid character for the data type being parsed was found. For example, an alpha "a" in a decimal number or "9" in an octal number.
- 116 Exponent is too large**
Indicates that the exponent was greater than 32,000 (refer to IEEE 488.2,7.7.2.4.1).
- 117 Too many numbers**
Indicates that the mantissa of a decimal figure contains more than 255 digits, excluding the leading zeros (refer to IEEE 488.2, 7.7.2.4.1).
- 118 Numeric data not allowed**
Indicates that a legal numeric-type data was received, but the device does not support it.
- 119 Suffix error**
This error, as well as errors from -120 to -122, is generated when the device is parsing a suffix. This error is generated when no more specific information is available.
- 120 Invalid suffix**
Indicates that the suffix does not conform to the syntax described in IEEE 488.2, 7.7.3.2 or the suffix is not applicable to this device.
- 121 Suffix is too long**
Indicates that the suffix contains more than 12 characters (refer to IEEE 488.2, 7.7.3.4).
- 122 Suffix not allowed**
Indicates that a suffix was found to be attached to a numeric element. The numeric element is not allowed to have any suffixes.
- 123 Character data error**
This error, as well as errors from -124 to -126, is generated when the device is parsing character data. This error is generated when no more specific information is available.
- 124 Invalid character data**
Indicates that the command header is invalid when the character data contains an invalid character or a particular character.
- 125 Character data is too long**
Indicates that the character data contains more than 12 characters (see IEEE 488.2, 7.7.1.4).
- 126 Character data not allowed**
Indicates that the legal character data appears in a position prohibited by the device.
- 127 String data error**
This error, as well as errors from -128 to -129, is generated when the device is parsing string data. This error is generated when no more specific information is available.
- 128 Invalid string data**
Indicates that string data was expected, but was invalid for some reason (refer to IEEE 488.2, 7.7.5.2). For example, an END message was received before the terminal quote character.
- 129 String data not allowed**
Indicates that a legal string data element was encountered but was not allowed by the device at this point in parsing.
- 130 Block data error**
This error, as well as errors from -131 to -132, is generated when the device is parsing

- a block data element. This error is generated when no more specific information is available.
- 131 **Invalid block data**
Indicates that a block data element was expected, but was invalid for some reason (refer to IEEE 488.2, 7.7.6.2). For example, an END message was received before the length satisfies the requirement.
 - 132 **Block data not allowed**
Indicates that a legal block data element was encountered but was not allowed by the device at this point in parsing.
 - 133 **Expression error**
This error, as well as errors from -134 to -135, is generated when the device is parsing an expression. This error is generated when no more specific information is available.
 - 134 **Invalid expression**
Indicates that the expression data element was invalid (refer to IEEE 488.2, 7.7.7.2). For example, unmatched parentheses or an illegal character.
 - 135 **Expression not allowed**
Indicates that the legal expression data was encountered but was not allowed by the device at this point in parsing.
 - 136 **Macro error**
This error, as well as errors from -137 to -139, is generated when the device is parsing a macro. This error is generated when no more specific information is available.
 - 137 **Invalid external macro definition**
Indicates that a macro parameter placeholder ($\$<number>$) was encountered outside of a macro definition.
 - 138 **Invalid content macro definition**
Indicates that the program message unit sequence, sent with a *DDT or *DMC command, is syntactically invalid (refer to IEEE 488.2, 10.7.6.3).
 - 139 **Macro parameter error**
Indicates that command parameter type or number as defined in the macro is wrong.

Execution Errors

- | NO. | Content |
|------|---|
| -140 | Execution error
Indicates a generic syntax error, which means no more detailed error information could be detected. This code indicates that only an Execution Error defined in IEEE 488.2, 11.5.1.1.5 has been found. |
| -141 | Invalid local mode execution
Indicates that the command cannot be executed because the device is in local mode (refer to IEEE 488.2, 5.6.1.5). You can select a proper communication interface to switch the instrument to the remote mode. |
| -142 | Command is protected
Indicates that the legal password-protected program command or query cannot be executed because the command was disabled. |
| -143 | Parameter error
Indicates an error in the program data element. This error message is generated when no more specific information is available as described in errors -144 through -148. |
| -144 | Setting conflict
Indicates that a legal program data element was found but cannot be executed due to the current device mode (refer to IEEE 488.2, 6.4.5.3 and 11.5.1.1.5.). |
| -145 | Data exceeds limit
Indicates that a legal program data element was found but cannot be executed because its interpreted value was outside of the legal range defined by the device (refer to IEEE |

488.2, 11.5.1.1.5.).

- 146 Too much data**
Indicates that a legal block, expression or string program data element was found but cannot be executed because it contained more data than the device could handle due to the memory limit of the device, related device requirements or the processing ability of the device.
- 147 Illegal parameter value**
You should use the specified value in the parameter list.
- 148 Out of memory**
Indicates that the device has insufficient memory to perform the request.
- 149 Invalid version**
Indicates that a legal program data element was found but cannot be executed because the version of the data is not supported by the device. This particular error message is generated when the file or block data format can be recognized by the device but cannot be executed due to version incompatibility. For example, an unsupported file version, an unsupported device version.
- 150 Hardware error**
Indicates that a legal program data or query was found but cannot be executed because of a hardware problem in the device. This error is generated when no more specific information is available as described in error -151.
- 151 Hardware cannot be found**
Indicates that a legal program data or query was found but cannot be executed because the hardware option was not installed.
- 152 Mass storage device error**
Indicates that a mass storage device error was found. This error message is generated when no more specific information is available as described in errors -153 through -159.
- 153 Mass storage device cannot be found**
Indicates that a legal program command or query was found but cannot be executed because no mass storage device was installed.
- 154 Storage device cannot be found**
Indicates that a legal program command or query was found but cannot be executed because no storage device can be found.
- 155 Storage media is damaged**
Indicates that a legal program command or query was found but cannot be executed because the disk was damaged or the format was incorrect.
- 156 Storage media is full**
Indicates that a legal program command or query was found but cannot be executed because there was insufficient space on the disk.
- 157 File with the specified filename cannot be found**
Indicates that a legal program command or query was found but cannot be executed because the file to be read or copied did not exist.
- 158 Filename error**
Indicates that a legal program command or query was found but cannot be executed because the name of the file to be copied was already in use.
- 159 Storage media is protected**
Indicates that a legal program command or query was found but cannot be executed because the disk was in write-protect mode.

Device-specific Errors

NO.	Content
-160	Device-specific error Indicates an error that cannot be specifically identified. This code indicates that only a Device-specific Error occurs as defined in IEEE 488.2, 11.5.1.1.6. In this case, please contact RIGOL sales personnel or technical support.
-161	System error Indicates an internal system-type error. In this case, please contact RIGOL sales personnel or technical support.
-162	Storage error Indicates that the local C disk was not formatted or an error occurred during self-test. If the problem persists after restarting the device, please contact RIGOL sales personnel or technical support.
-163	Calibration data lost Indicates that the factory calibration data or the last effective calibration data was lost. In this case, please contact RIGOL sales personnel or technical support.
-164	Store and recall internal memory lost Indicates that the non-volatile data saved by the *SAV? command was lost.
-165	Configuration data lost Indicates that the non-volatile configuration data saved by the device was lost.
-166	Out of memory Indicates that an internal operation needed more memory than that was available. In this case, please contact RIGOL sales personnel or technical support.
-167	Self-test failed Indicates a failure in the self-test. For more information, please refer to the self-test results.
-168	Calibration failed Indicates a failure in the calibration. Please report the error to RIGOL sales personnel or technical support.
-169	Query queue overflow Indicates an error occurred that did not get put in the error queue because the queue was full.
-170	Communication interface error
-171	Timeout error Indicates that when communicating with the USB-GPIB interface converter, the time exceeds the required time. Please restart the converter.
305	The file or directory does not exist
306	Failed to open the file
307	This type of file cannot be loaded
310	Invalid operation. Can only unfold folder or disk
311	No enough storage space The remaining disk space was not enough for creating or storing the file or folder.
312	Copy operation failed
314	Failed to save the file
316	Failed to delete the file
319	Failed to format the local disk
321	Failed to install the USB storage device Indicates that the USB storage device cannot be correctly installed. Check whether the USB storage device is damaged. For more information, please contact RIGOL technical support.

- 323 Failed to exit the USB storage device**
- 326 Rename failed**
- 327 Failed to create a new folder**
- 329 The filename or directory name is incorrect**
Indicates that you entered the illegal string.
- 330 Failed to update**
Indicates that the update operation failed because the image file format was incorrect or the image file was damaged.
- 332 The filename already exists**
The filename input already exists and please input another filename.
- 4210 Invalid option license**
Indicates that the option license series No. that you entered has exceeded the required 20 characters.
- 4228 Option license initialization error**
- 4229 Option license installation error**
- 4230 Basic device information initialization error**
- 4235 The DHCP configuration is failed**
Indicates a failure in configuring the IP address by using DHCP configuration mode. Users can try to configure the IP address using manual IP configuration mode.
- 4236 IP address conflict**
Indicates that the IP address that you set was already in use. Please try to set another IP address that is not currently used.
- 4239 The network is not bound**
- 4245 Unrecognized device**
- 4246 Reverse power exceeds the limit**
Indicates that the reverse power exceeds the limit. The device might be damaged if it works in this condition for a long period of time.
- 4247 The network initialization is not completed**

Query Errors

NO.	Content
-172	Query error Indicates a query error that cannot be specifically identified. This code indicates that only Query Errors defined in IEEE 488.2, 11.5.1.1.7 and 6.3 occurred.
-173	Query INTERRUPTED error Indicates that an INTERRUPTED query error occurred due to some reason (refer to IEEE 488.2, 6.3.2.3). For example, a query was added to DAB or GET before a response was completely sent.
-174	Query UNTERMINATED Indicates that an UNTERMINATED query error occurred due to some reason (refer to IEEE 488.2, 6.3.2.2). For example, the device was assigned with an address and began to communicate; but an incomplete message was received.
-175	Query DEADLOCKED Indicates that a DEADLOCKED query error occurred due to some reason (refer to IEEE 488.2, 6.3.1.7). For example, both the input buffer and output buffer are full and the device cannot keep running.
-176	Query UNTERMINATED is undefined after the response Indicates that before the error response generated from the previous query was resolved, another query request was received (refer to IEEE 488.2, 6.5.7.5).

Appendix B: Software Update

Software Update Preparations

1. Prepare a DSG800 series RF signal generator that requires software update.
2. Prepare a USB storage device that contains the latest version of the update file. The name of the update file is DSG800_UpdateFile.sys.

Software Update Methods

1. Update the software in the Local Booting interface during the start-up
 - (1) Insert the USB storage device (with the update file in it) into the USB HOST interface on the rear panel of DSG800.
 - (2) After correctly connecting the power supply, press the power key on the front panel to turn on the RF signal generator.
 - (3) In the Local Booting interface, press **Preset** according to the prompt message.
 - (4) View the prompt messages ("Scanning..." and then "Flash writing..."; the **RF/on** and **Mod/on** keys were illuminated.) and wait until the update is completed.
 - (5) After the update operation has been successfully completed, the **RF/on** and **Mod/on** keys go off and the instrument starts normally.
2. Update the software in the Storage interface after the instrument starts
 - (1) Insert the USB storage device (with the update file in it) into the USB HOST interface on the rear panel of DSG800.
 - (2) After correctly connecting the power supply, press the power key on the front panel to turn on the RF signal generator.
 - (3) Press **Save** on the front panel to enter the Storage interface.
 - (4) Rotate the knob to select Disk E (available when an USB storage device is detected) and press the right direction key to unfold the current directory.
 - (5) Select the update file and press **Update**.
 - (6) View the prompt messages and wait until the update is completed.
 - (7) The instrument restarts automatically after the update succeeds.