

SAL737

SMARTMOUNT **LT**

# Articulating Wall Mount For 22" to 37" Displays

**Touchboards**

205 Westwood Ave, Long Branch, NJ 07740  
Phone: 866-94 BOARDS (26273) / (732)-222-1511  
Fax: (732)-222-7088 | E-mail: sales@touchboards.com

The SmartMountLT™ series articulating wall mounts give the ultimate in display positioning, with one-person, Hook-and-Hang™ easy installation. The articulating arm allows you to extend the display up to 14.58" (370mm) from the wall, and can retract to just 2.48" (63mm) from the wall. The integrated cable management provides a clean, professional finish. One-Touch™ tilt of  $\pm 15^\circ$ ,  $\pm 5^\circ$  roll for post-installation leveling and  $\pm 90^\circ$  pivoting means the display will be perfectly positioned for the optimum viewing angle.



Display size: 22"-37"



Max load: 55lb (25kg)

## FEATURES

- Fits 22" to 37" displays, up to 55lb (25kg)
- Extends display 14.58" (370mm) from the wall
- Retracts to hold display 2.48" (63mm) from the wall
- $\pm 90^\circ$  of pivot allows for perfect display positioning
- Quick and easy, Hook-and-Hang™ one-person installation
- Integrated cable management provides clean, professional installation finish
- Easy leveling  $\pm 5^\circ$  after display installation
- Landscape or portrait mounting options increases display versatility
- Mounts to wood studs, concrete, cinder block or metal studs (metal stud accessory required)
- VESA® 75, 100, 100 x 200, 200 x 100, and 200 x 200mm compliant
- Installation hardware included
- UL Listed
- Five-year warranty

**KEYHOLE DESIGN**  
Saves installation time

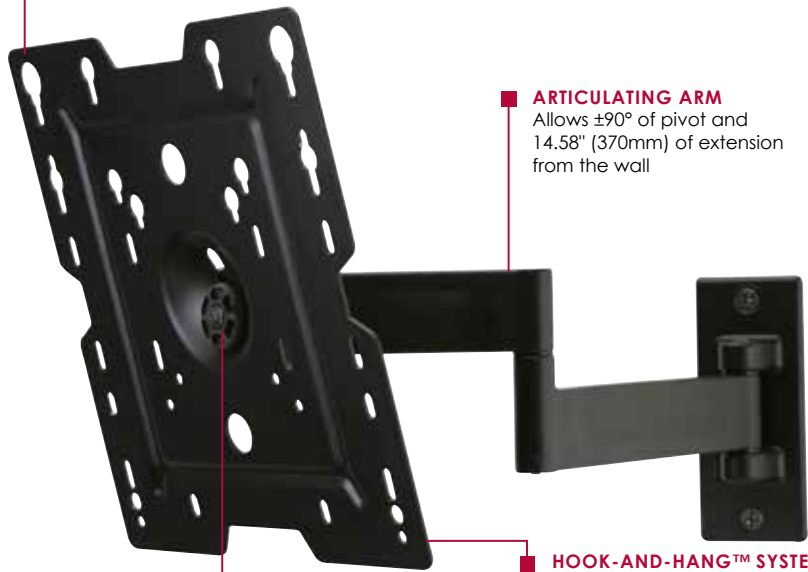

**ARTICULATING ARM**  
Allows  $\pm 90^\circ$  of pivot and 14.58" (370mm) of extension from the wall

**ONE-TOUCH™ TILT**  
Offers  $\pm 15^\circ$  of viewing angle adjustment

**HOOK-AND-HANG™ SYSTEM**  
Offers easy, one-person installation of the display



$\pm 15^\circ$  of viewing angle adjustment



Arm retracts to just 2.48" (63mm) and extends up to 14.58" (370mm) from the wall



CLICK: peerless-av.com

CALL: 800.865.2112

FAX: 800.359.6500

peerless-AV

<b>SAL737</b>	SmartMountLT™ Articulating Wall Mount for 22" to 37" Displays
---------------	---

Product Specifications

	DIMENSIONS (W x H x D)	PRODUCT WEIGHT	LOAD CAPACITY	FINISH	AVAILABLE COLORS
<b>SAL737</b>	9.54" x 9.70" x 2.48"-14.58" (242 x 246 x 63-370mm)	3.43lb (1.56kg)	55lb (25kg)	Matte	Black

Package Specifications

	PACKAGE SIZE (W x H x D)	PACKAGE SHIP WEIGHT	PACKAGE UPC CODE	PACKAGE CONTENTS	UNITS IN PACKAGE
<b>SAL737</b>	10.80" x 10.20" x 2.50" (274 x 259 x 64mm)	4.40lb (2.00kg)	735029292548	Wall mount, attachment hardware and installation instructions	1

Accessories

<b>ACC973:</b>	VESA® 400 X 400mm Adaptor Plates	<b>ACC975:</b>	Security Fasteners
<b>ESHV10:</b>	Single AV Wall Shelf	<b>WSP700/701:</b>	Metal Stud Wall Plate
<b>ESHV20:</b>	Single AV Wall Shelf with Glass		
<b>ESHV30:</b>	Dual AV Wall Shelf with Glass		

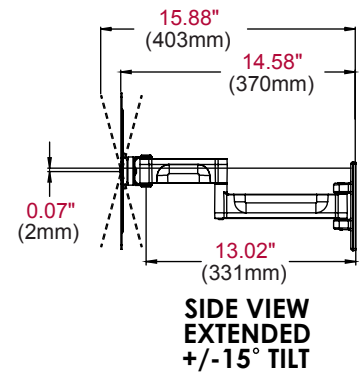
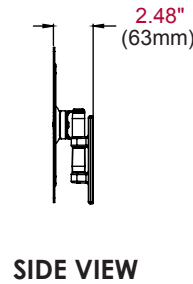
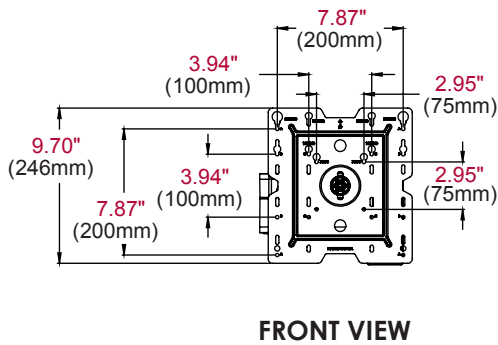
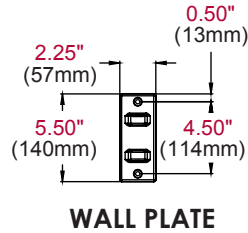
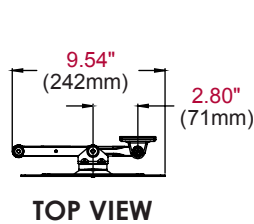

**Touchboards**  
 205 Westwood Ave, Long Branch, NJ 07740  
 Phone: 866-94 BOARDS (26273) / (732)-222-1511  
 Fax: (732)-222-7088 | E-mail: sales@touchboards.com

ARCHITECTS SPECIFICATIONS

The Articulating Wall Mount shall be a Peerless-AV model SAL737 and shall be located where indicated on the plans. Assembly and installation shall be done according to instructions provided by the manufacturer.