

Handheld Density Meter SG-Pro

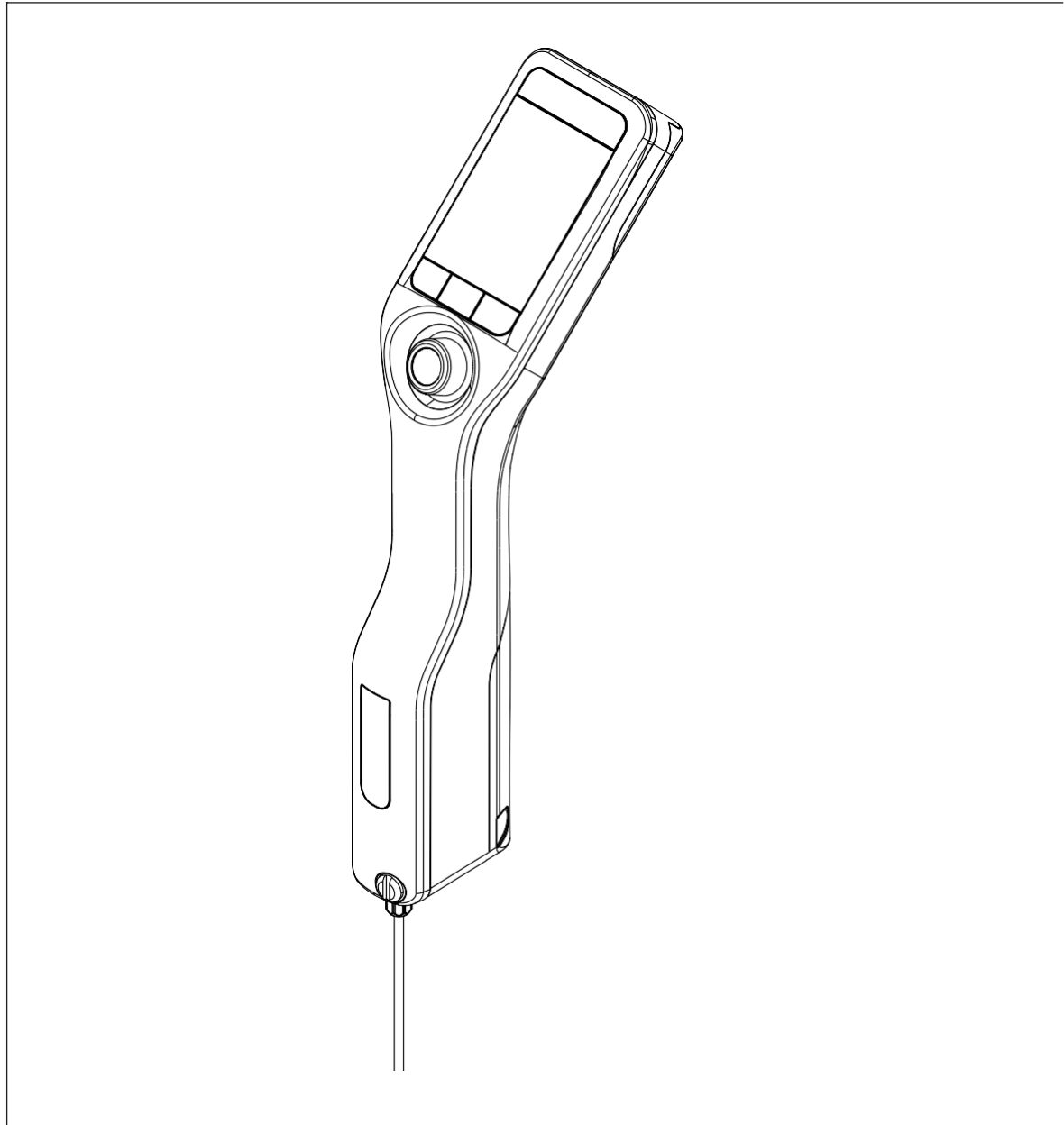

EAGLE EYE
POWER SOLUTIONS

Table of Contents

| | | |
|----------|--|-----------|
| 1 | Introduction | 5 |
| 2 | Safety Information | 6 |
| 2.1 | Definitions of signal words and warning symbols | 6 |
| 2.2 | Product specific safety notes | 6 |
| 3 | Design and Function | 8 |
| 3.1 | Instrument overview..... | 8 |
| 3.2 | Overview of functions | 8 |
| 3.3 | User interface..... | 10 |
| 3.3.1 | Home screen..... | 10 |
| 3.3.2 | Icons on the screen | 10 |
| 4 | Installation and commissioning | 11 |
| 4.1 | Scope of delivery | 11 |
| 4.2 | Unpack the density meter..... | 11 |
| 4.3 | Charge the density meter | 12 |
| 4.3.1 | Charge with the AC adapter..... | 12 |
| 4.3.2 | Charge with a computer | 12 |
| 4.4 | Setup for working with the sample pump | 13 |
| 4.4.1 | Activate the sample pump mode..... | 13 |
| 4.4.2 | Install the filling tube | 13 |
| 4.5 | Activate and deactivate the RFID reader (DensitoPro only) | 13 |
| 4.6 | Activate and deactivate the barcode reader (DensitoPro only) | 13 |
| 4.7 | Install accessories | 14 |
| 4.7.1 | Setup for working with a syringe..... | 14 |
| 4.7.1.1 | Activate the syringe mode | 14 |
| 4.7.1.2 | Install the connector for the syringe | 15 |
| 4.7.2 | Connect a printer | 15 |
| 4.7.2.1 | Connect a USB printer | 16 |
| 4.7.2.2 | Connect a bluetooth printer | 16 |
| 4.7.2.3 | Print a test page | 16 |
| 4.7.3 | Connect to EasyDirect Density & Refractometry..... | 17 |
| 4.8 | Configure the density meter | 17 |
| 4.8.1 | Change the date and time format..... | 17 |
| 4.8.2 | Change the temperature unit..... | 18 |
| 4.8.3 | Change the density unit | 18 |
| 4.8.4 | Change energy saver settings..... | 18 |
| 4.8.5 | Protect actions with a password..... | 19 |
| 4.8.5.1 | Enable the password protection | 19 |
| 4.8.5.2 | Disable the password protection | 19 |
| 4.8.5.3 | Change the password | 20 |
| 4.8.6 | Activate and deactivate the auto rotation of the screen..... | 20 |
| 4.8.7 | Activate and deactivate the audio signal | 20 |
| 4.8.8 | Change the keyboard layout..... | 20 |
| 4.8.9 | Change the language..... | 20 |
| 4.8.10 | Activate and deactivate a cleaning reminder | 20 |
| 4.9 | Configure density determinations..... | 21 |
| 4.9.1 | Create, change or delete a method | 21 |
| 4.9.1.1 | Create a method..... | 21 |
| 4.9.1.2 | Change a method | 22 |
| 4.9.1.3 | Delete a method | 22 |
| 4.9.2 | Change a test..... | 22 |
| 4.9.3 | Change an adjustment..... | 22 |
| 4.9.4 | Configure the user guidance..... | 23 |

| | | |
|----------|---|-----------|
| 4.9.4.1 | Define the level of user guidance | 23 |
| 4.9.4.2 | Define the pump speed | 23 |
| 4.9.4.3 | Define the fill cycle (only guided workflow) | 23 |
| 4.9.4.4 | Define the cleaning type (only guided workflow) | 23 |
| 4.9.4.5 | Activate and deactivate the confirmation of results | 24 |
| 4.9.5 | Configure the measurement reliability | 24 |
| 4.9.6 | Configure the result conversion | 24 |
| 4.9.6.1 | Density and specific gravity | 25 |
| 4.9.6.2 | Alcohol concentration | 26 |
| 4.9.6.3 | American Petroleum Institute (API)..... | 26 |
| 4.9.6.4 | Baumé scale | 26 |
| 4.9.6.5 | Sulfuric acid concentration | 27 |
| 4.9.6.6 | Sugar concentration | 27 |
| 4.9.6.7 | User defined concentration | 27 |
| 4.9.6.8 | Define the temperature-compensation coefficient α | 29 |
| 4.9.7 | Configure the automatic documentation of results..... | 30 |
| 4.9.7.1 | Configure the sample or standard identification | 30 |
| 4.9.7.2 | Configure the automatic printing of results | 31 |
| 4.9.7.3 | Configure the automatic export of results | 32 |
| 4.9.8 | Configure result limits..... | 32 |
| 4.9.9 | Configure a standard | 32 |
| 4.9.10 | Configure the tolerance for a test | 33 |
| 5 | Operation | 34 |
| 5.1 | Start up the density meter | 34 |
| 5.2 | Shut down the density meter..... | 34 |
| 5.3 | Navigate and enter information | 35 |
| 5.3.1 | Navigate through menus and confirm settings | 35 |
| 5.3.2 | Enter text and numbers | 35 |
| 5.4 | Typical phases of density determinations | 36 |
| 5.4.1 | Fill the measuring cell and measure the density..... | 36 |
| 5.4.2 | Prepare the measuring cell for the next sample | 36 |
| 5.5 | Example: Density determination using the sample pump..... | 36 |
| 5.5.1 | Configure the method..... | 37 |
| 5.5.2 | Perform the density determination..... | 38 |
| 5.6 | Example: Density determination using a syringe | 39 |
| 5.6.1 | Configure the method..... | 39 |
| 5.6.2 | Perform the density determination..... | 40 |
| 5.7 | Example: Density determination of cold or hot samples..... | 42 |
| 5.7.1 | Configure the method..... | 42 |
| 5.7.2 | Perform the density determination..... | 43 |
| 5.8 | Read and write information with the RFID reader (DensitoPro only) | 44 |
| 5.8.1 | Write information to a Smart Tag..... | 45 |
| 5.8.2 | Read information from a Smart Tag | 45 |
| 5.9 | Read information with the barcode reader (DensitoPro only) | 45 |
| 5.10 | View, export, print and delete results | 46 |
| 5.10.1 | View results | 46 |
| 5.10.2 | Delete all results | 46 |
| 5.10.3 | Export and print results | 46 |
| 5.10.3.1 | Export results to EasyDirect Density & Refractometry | 47 |
| 5.10.3.2 | Print results | 47 |
| 5.10.3.3 | Configure the filter | 48 |
| 6 | Maintenance | 49 |
| 6.1 | Maintenance schedule | 49 |
| 6.2 | Clean the density meter | 49 |
| 6.2.1 | Clean the housing | 49 |
| 6.2.2 | Clean the measuring cell..... | 50 |

| | | |
|-----------|--|-----------|
| 6.2.2.1 | Clean using the sample pump | 50 |
| 6.2.2.2 | Clean using a syringe | 51 |
| 6.3 | Check the measurement accuracy | 51 |
| 6.3.1 | Example: Test with water | 51 |
| 6.3.1.1 | Configure the test | 52 |
| 6.3.1.2 | Perform the test | 52 |
| 6.3.2 | Measures if a test fails | 53 |
| 6.4 | Replace the battery | 53 |
| 6.5 | Replace the filling tube | 54 |
| 6.6 | Replace the sample pump | 54 |
| 6.7 | Update the firmware | 55 |
| 6.8 | Prepare the density meter for storage | 55 |
| 6.9 | Ship the density meter | 55 |
| 6.10 | Dispose of the density meter | 56 |
| <hr/> | | |
| 7 | Troubleshooting | 57 |
| 7.1 | List of errors and problems | 57 |
| 7.2 | Restore the factory adjustment data | 58 |
| 7.3 | Adjust the measurement accuracy | 58 |
| 7.3.1 | Example: Adjustment with water | 59 |
| 7.3.1.1 | Configure the adjustment | 59 |
| 7.3.1.2 | Perform the adjustment | 59 |
| 7.4 | Restore the factory settings | 61 |
| 7.5 | View the firmware version and other system information | 61 |
| <hr/> | | |
| 8 | Technical data | 62 |
| 8.1 | Density meter | 62 |
| 8.2 | Measurement | 63 |
| <hr/> | | |
| 9 | Accessories | 65 |
| 9.1 | Sampling | 65 |
| 9.2 | Printers | 66 |
| 9.3 | Miscellaneous accessories | 66 |
| <hr/> | | |
| 10 | Appendix | 68 |
| 10.1 | Density of pure water (0...40 °C) | 68 |
| 10.2 | Temperature-compensation coefficients α | 68 |
| <hr/> | | |
| | Index | 69 |

1 Introduction

Thank you for choosing an Eagle Eye Power Solutions density meter. The handheld density meters SG-Pro and DensitoPro are handheld measuring instruments used to determine the density of liquids.

About this document

The instructions in this document refer to handheld density meters SG-Pro and DensitoPro running firmware version V1.0.0 or higher.

The firmware license is subject to the End User License Agreement EULA version 3.0.

If you have any additional questions, contact your authorized EEPS dealer or service representative.

Conventions and symbols

Note for useful information about the product.



Refers to an external document.

Elements of instructions

- Prerequisites

1 Steps

2 ...

⇒ Intermediate results

⇒ Results

See also

 View the firmware version and other system information } Page 61

2 Safety Information

- This Reference Manual contains a full description of the instrument and its use.
- Keep the Reference Manual for future reference.
- Include the Reference Manual if you transfer the instrument to other parties.

Only use the instrument according to the Reference Manual. If you do not use the instrument according to the Reference Manual or if it is modified, the safety of the instrument may be impaired and EEPS assumes no liability.

2.1 Definitions of signal words and warning symbols

Safety notes contain important information on safety issues. Ignoring the safety notes may lead to personal injury, damage to the instrument, malfunctions and false results. Safety notes are marked with the following signal words and warning symbols:

Signal words

WARNING A hazardous situation with medium risk, possibly resulting in death or severe injury if not avoided.

NOTICE A hazardous situation with low risk, resulting in damage to the instrument, other material damage, malfunctions and erroneous results, or loss of data.

Warning symbols



Electrical shock

2.2 Product specific safety notes

Intended use

The density meter is designed to be used by trained staff and is intended for measuring the density of liquid samples that are compatible with the materials with which they come into contact.

The density meter is designed for indoor and outdoor operation in dry conditions. The following site requirements apply:

- The ambient conditions are within the limits specified in the technical data.
- No corrosive gas atmosphere
- No explosive atmosphere
- No powerful electric or magnetic fields

Any other type of use and operation beyond the limits of use stated by EEPS without consent from EEPS is considered as not intended.

This device complies with Industry Canada licence-exempt RSS standard(s) and part 15 of the FCC Rules. Operation is subject to the following two conditions: (1) this device may not cause interference, and (2) this device must accept any interference, including interference that may cause undesired operation of the device. Changes or modifications not expressly approved by the party responsible for compliance could void the user's authority to operate the equipment.

Responsibilities of the instrument owner

The instrument owner is the person holding the legal title to the instrument and who uses the instrument or authorizes any person to use it, or the person who is deemed by law to be the operator of the instrument. The instrument owner is responsible for the safety of all users of the instrument and third parties.

EEPS assumes that the instrument owner trains users to safely use the instrument in their workplace and deal with potential hazards. EEPS assumes that the instrument owner provides the necessary protective gear.

Safety notes



WARNING

Danger of death or serious injury due to electric shock!

Contact with parts that carry a live current can lead to death or injury.

- 1 Only use the AC adapter designed for your instrument.
- 2 Keep all electrical cables and connections away from liquids and moisture.
- 3 Check the cables and the plugs for damage and replace damaged cables and plugs.



NOTICE

Risk of damage to the instrument due to the use of unsuitable parts!

Using unsuitable parts with the instrument can damage the instrument or cause it to malfunction.

- Only use parts from EEPS that are intended to be used with your instrument.

3 Design and Function

3.1 Instrument overview

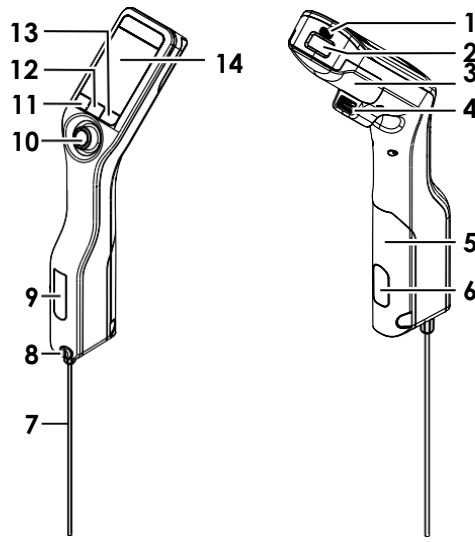

| No. | Name | Function |
|-----|--|---|
| 1 | USB-C socket | To connect the density meter with the AC adapter or a computer. |
| 2 | RFID reader and barcode reader (DensitoPro only) | To scan a linear barcode or read and write information to Smart Tags. |
| 3 | Battery cover | To access the battery. |
| 4 | USB-A socket | To connect a USB printer or bluetooth dongle. |
| 5 | Sample pump cover | To access the sample pump. |
| 6 | Sample pump window | To view the sample pump and to check if the sample pump is filled or empty. |
| 7 | Filling tube | To fill and drain the measuring cell. |
| 8 | Filling opening with locking screw | To fill and drain the measuring cell using a syringe. The locking screw closes off the filling opening. |
| 9 | Measuring cell window | To view the measuring cell and to check if the measuring cell is filled or empty. |
| 10 | Navigation joystick | To navigate through the menus. |
| 11 | Key 1 | To start up the density meter, select menu items and to navigate. |
| 12 | Key 2 | To select menu items and to navigate. |
| 13 | Key 3 | To select menu items and to navigate. |
| 14 | Screen | To display settings and results. |

3.2 Overview of functions

The density meter uses the oscillating body method as measurement technology. The density meter has no active temperature control.

If you measure samples with low viscosity, you can use the sample pump (1) and the filling tube (2) to fill the measuring cell (5). For samples with high viscosity you can use a syringe (3) and the connector for the syringe (4) to fill the measuring cell (5). The user can observe the filling through the window of the measuring cell.

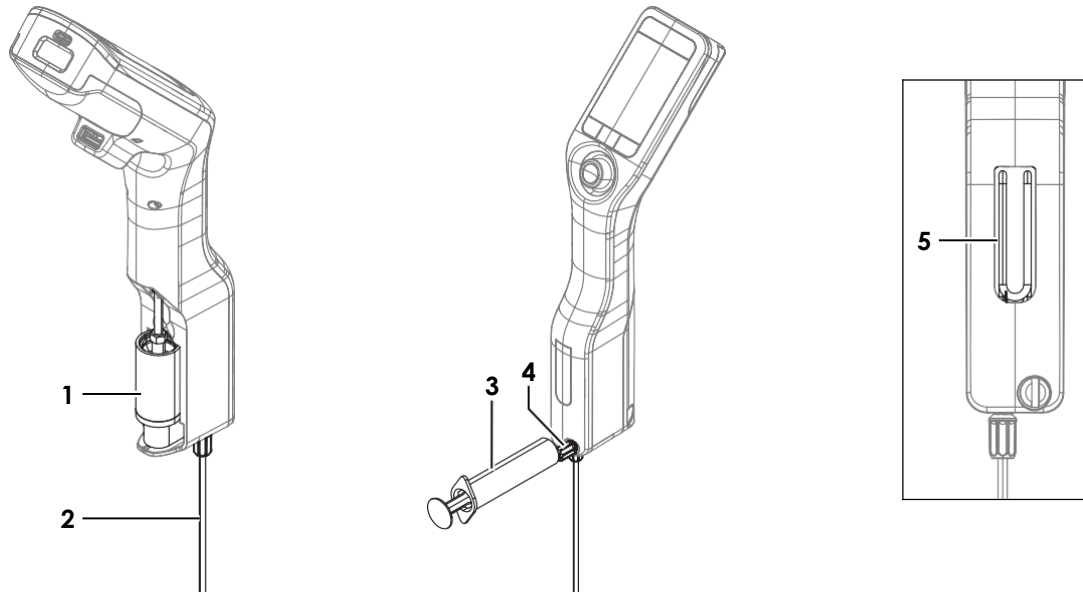

For repeated measurements, you can define and save workflows as methods. Two workflow types are available:

- Customizable guided workflow: guides the user step by step through the density determination.
- Unguided workflow: the user decides which steps are needed.

The results are automatically converted into one of the following predefined units or a unit that the user defines.

- Density
- Specific gravity
- Alcohol concentration
- American Petroleum Institute (API density, API specific gravity, API degree)
- Baumé scale
- Sulfuric acid concentration
- Sucrose concentration

3.3 User interface

3.3.1 Home screen

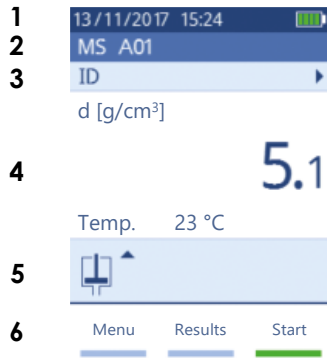

| No. | Name | Explanation |
|-----|---------------------|---|
| 1 | Status ribbon | Displays the current date, time, battery charge status and connection to accessories like EasyDirect Density & Refractometry. |
| 2 | Method ribbon | Displays the type of density determination and the method identification or the selected standard. <ul style="list-style-type: none"> • MS: measurement using a method • TE: test • ADJ: adjustment |
| 3 | Sample ID ribbon | Displays the sample ID. |
| 4 | Measuring ribbon | Displays the unit, the measured value or result and the temperature of the measuring cell. |
| 5 | Sampling ribbon | Displays the current status of the sample pump or syringe. |
| 6 | Keyfunctions ribbon | Displays the function of the keys. |

3.3.2 Icons on the screen

| Icon | Location | Explanation |
|------|-----------------|---|
| | Status ribbon | Barcode reader is scanning. |
| | Status ribbon | RFID reader is reading or writing. |
| | Status ribbon | EasyDirect Density & Refractometry is connected. |
| | Status ribbon | Density meter is sending data to the printer. |
| | Status ribbon | Shows the charge of the battery. |
| | Status ribbon | Battery is charging. |
| | Sampling ribbon | Syringe mode activated. The sample pump is deactivated. |
| | Sampling ribbon | Sample pump activated and piston in the lowermost position. |
| | Sampling ribbon | Sample pump activated and piston in the uppermost position. |

4 Installation and commissioning

4.1 Scope of delivery

| Part | Ordernumber | SG-Pro | DensitoPro |
|--|-------------|--------|------------|
|  Handheld density meter | – | • | • |
|  Filling Tube 190 mm • Tube • Connector syringe/filling tube • Washer | 30330847 | • | • |
|  Battery Li-Ion 2400mAh | 30330855 | • | • |
|  Power Supply and Worldwide Adapters | 30449255 | • | • |
|  USB-C Cable | 30449253 | • | • |
|  Density standards (3 pcs) 6 mL | 51325005 | • | • |
|  Tag SmartSample (10 pcs) | 30449268 | – | • |
|  User Manual | – | • | • |
|  Declaration of conformity | – | • | • |
|  Test report | – | • | • |

4.2 Unpack the density meter

- 1 Remove the density meter from the protective packaging.
- 2 Store the packing material for later transport over long distances.
- 3 Check if you received all parts listed in the scope of delivery.
- 4 Inspect the parts visually for flaws or damage.
- 5 If parts are missing or damaged, report it immediately and file a freight claim if needed.

4.3 Charge the density meter

You can either charge the density meter using the supplied AC adapter or a computer. Recharging an empty battery takes approximately three hours.

4.3.1 Charge with the AC adapter

The AC adapter is suitable for all supply line voltages ranging from 100...240 V AC and 50/60 Hz.



⚠ WARNING

Danger of death or serious injury due to electric shock!

Contact with parts that carry a live current can lead to death or injury.

- 1 Only use the AC adapter designed for your instrument.
- 2 Keep all electrical cables and connections away from liquids and moisture.
- 3 Check the cables and the plugs for damage and replace damaged cables and plugs.



NOTICE

Danger of damage to the AC adapter due to overheating!

If the AC adapter is covered or in a container, it is not sufficiently cooled and overheats.

- 1 Do not cover the AC adapter.
- 2 Do not put the AC adapter in a container.

Assemble the AC adapter

- 1 Slide the desired set of prongs (1) into the AC adapter (2).
- 2 Insert the USB-A plug of the USB-C cable in the USB-A socket of the AC adapter.

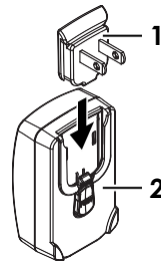

Connect the density meter to the power supply

- 1 Insert the USB-C plug of the USB-C cable in the USB-C socket of the density meter.
 - 2 Install the cables in such a way that they cannot be damaged or interfere with operation.
 - 3 Insert the plug of the AC adapter in a power outlet that is easily accessible.
- ⇒ The density meter starts charging and the  icon is displayed.

Change the prongs of the AC adapter

- 1 Pull the plug of the AC adapter out of the power outlet.
- 2 Push the button (2) and slide the set of prongs (1) out.
- 3 Slide the desired set of prongs into the AC adapter.

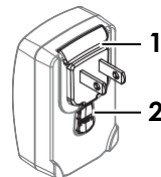

4.3.2 Charge with a computer

- A running computer with USB-A sockets (USB 2.0 or higher) is available.
- 1 Insert the USB-C plug of the USB-C cable in the USB-C socket of the density meter.
 - 2 Install the cables in such a way that they cannot be damaged or interfere with operation.

- 3 Insert the USB-A plug in the USB-A socket of the computer.
⇒ The density meter starts charging and the  icon is displayed.

4.4 Setup for working with the sample pump

4.4.1 Activate the sample pump mode

- 1 Press the **Menu** key.
- 2 Navigate to **Settings > Measurement > Sampling**.
⇒ The **Sampling** window opens.
- 3 Navigate to **Sample pump**.
- 4 Press the **OK** key.
- 5 Navigate back to the home screen.
⇒ The icon  is displayed in the sampling ribbon.

4.4.2 Install the filling tube

- The filling tube (tube (1), connector (2) and washer (3)) is assembled.
- The locking screw (2) is installed and tight.
- Screw the connector (1) of the filling tube into the opening (3) and tighten it.

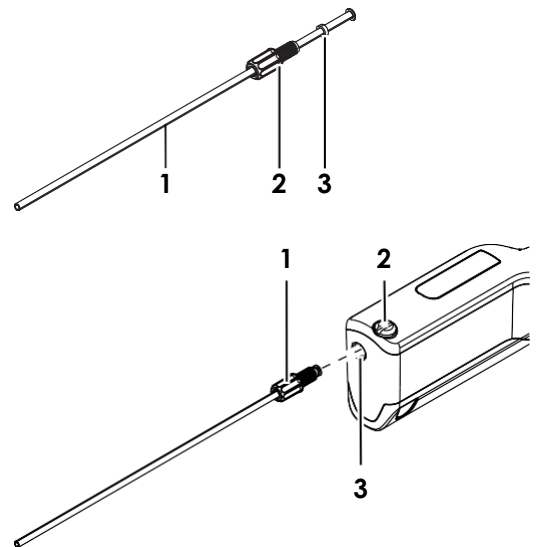

4.5 Activate and deactivate the RFID reader (DensitoPro only)

- 1 Press the **Menu** key.
- 2 Navigate to **Settings > RFID / Barcode > Type**.
⇒ The **Type** window opens.
- 3 To activate the RFID reader, navigate to **RFID**.
- 4 To deactivate the RFID reader, navigate to **None**.
- 5 Press the **OK** key.

See also

 Read and write information with the RFID reader (DensitoPro only) } Page 44

4.6 Activate and deactivate the barcode reader (DensitoPro only)

- 1 Press the **Menu** key.
- 2 Navigate to **Settings > RFID / Barcode > Type**.
⇒ The **Type** window opens.

- 3 To activate the barcode reader, navigate to **Barcode**.
- 4 To deactivate the barcode reader, navigate to **None**.
- 5 Press the **OK** key.

See also

📖 Read information with the barcode reader (DensitoPro only) } Page 45

4.7 Install accessories

4.7.1 Setup for working with a syringe

When you work with a syringe you can place the density meter either on the bench or hold it upright.

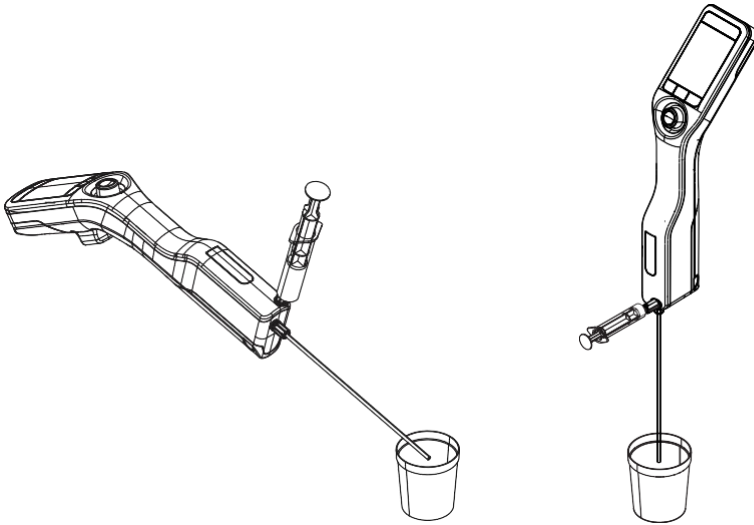

4.7.1.1 Activate the syringe mode

- The piston is in the lowermost position.
- 1 Press the **Menu** key.
 - 2 Navigate to **Settings > Measurement > Sampling**.
 - ⇒ The **Sampling** window opens.
 - 3 Navigate to **Syringe**.
 - 4 Press the **OK** key.
 - 5 Navigate back to the home screen.
 - ⇒ The icon  is displayed in the sampling ribbon.
 - 6 If you want place the density meter on the bench, activate the auto rotation of the screen.

See also

📖 Activate and deactivate the auto rotation of the screen } Page 20

4.7.1.2 Install the connector for the syringe

- The connector for the syringe is available.
 - The filling tube is installed.
- 1 Unscrew the locking screw counterclockwise with a flat screwdriver and remove it.

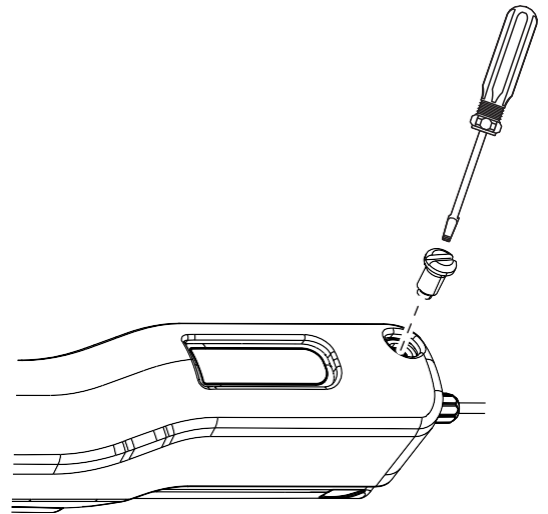

- 2 Screw the connector into the filling opening and tighten it.

See also

📖 Accessories } Page 65

📖 Install the filling tube } Page 13

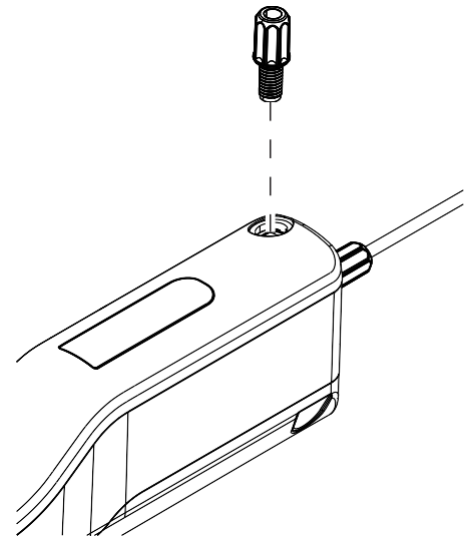

4.7.2 Connect a printer

In order to print the results right after the measuring procedure, the density meter has to be connected to a USB or Bluetooth printer. Alternatively the results can be printed at a later time from the **Results** menu.

The following printer types are compatible with the density meter:

| Connection type | Printer |
|-----------------|------------|
| Bluetooth | Godex MX20 |
| USB | P25 |

Note

The bluetooth function is only available in selected countries with the necessary approvals. For more information, contact an authorized EEPS dealer or service representative.



fer to the user documentation of your printer for setting up and operating the printer.

See also

Accessories } Page 65

4.7.2.1 Connect a USB printer

- 1 Press the **Menu** key.
- 2 Navigate to **Settings > Printer > Printer type**.
⇒ The **Printer type** window opens.
- 3 Navigate to **USB**.
- 4 Press the **OK** key.
- 5 Connect the USB-A plug of USB-C cable with the USB-A socket of the printer.
- 6 Connect the USB-A plug with the USB-A socket of the density meter.
- 7 Switch on the printer.
⇒ The connection is established.

See also

Configure the automatic printing of results } Page 31

Print results } Page 47

4.7.2.2 Connect a bluetooth printer

- The bluetooth printer is set up and running.
- 1 Insert the bluetooth dongle in the USB-A socket of the density meter.
 - 2 Press the **Menu** key.
 - 3 Navigate to **Settings > Printer > Printer type**.
⇒ The **Printer type** window opens.
 - 4 Navigate to **Bluetooth**.
 - 5 Press the **OK** key.
 - 6 Press the **Menu** key.
 - 7 Navigate to **Printer selection**.
⇒ The **Printer selection** window with a list of available bluetooth printers opens.
 - 8 Navigate to the bluetooth printer you want to connect.
 - 9 Press the **OK** key.

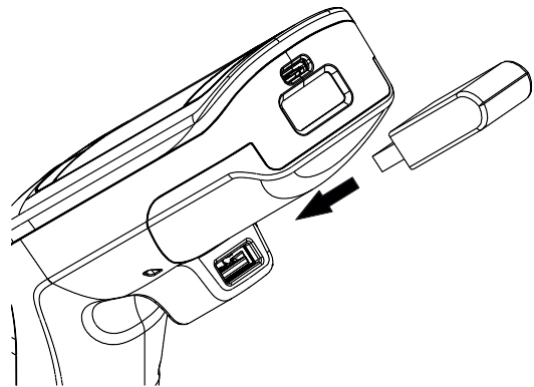

See also

Configure the automatic printing of results } Page 31

Print results } Page 47

4.7.2.3 Print a test page

- The printer is connected and running.
- 1 Press the **Menu** key.
 - 2 Navigate to **Settings > Printer > Test printer**.
⇒ If there is no connection yet, the notification **Connecting to printer** is displayed.
⇒ When the connection is established, a test page is printed.

See also

 Connect a printer } Page 15

4.7.3 Connect to EasyDirect Density & Refractometry

EasyDirect Density & Refractometry is a data management software to manage a database of measurement results. By connecting the density meter via a USB-C cable to a computer on which EasyDirect Density & Refractometry is installed, the data can be directly exported to the software.



Operating EasyDirect Density & Refractometry is described in the help of the software.

Procedure

- EasyDirect Density & Refractometry is installed on the computer.
 - A USB-C cable is available.
- 1 Insert the USB-C plug of the USB-C cable in the USB-C socket of the density meter.
 - 2 Insert the USB-A plug in a USB-A socket on the computer.
 - 3 Add the density meter to the list of instruments on EasyDirect Density & Refractometry.
- ⇒ The icon  is displayed in the status ribbon.

See also

 Export results to EasyDirect Density & Refractometry } Page 47

4.8 Configure the density meter

4.8.1 Change the date and time format

The following date formats are available:

- **dd/mm/yyyy**: day/month/year, e.g. 30/11/2018
- **mm/dd/yyyy**: month/day/year, e.g. 11/30/2018
- **yyyy/mm/dd**: year/month/day, e.g. 2018/11/30
- **dd.mm.yyyy**: day.month.year, e.g. 30.11.2018

The following two time formats are available.

- **24 h**: 24-hour clock, e.g. 6:30 and 18:30
- **am/pm**: 12-hour clock, e.g. 6:30 am and 6:30 pm

Procedure

- 1 Press the **Menu** key.
- 2 Navigate to **Settings > Date / Time**.
⇒ The **Date / Time** window opens.
- 3 Navigate to **Date** or **Time**.
- 4 To change the date or time, move the navigation joystick up to raise or down to lower the number.
- 5 To switch between day, month and year or hours and minutes, move the navigation joystick to the left or right.
- 6 Press the **OK** key.
- 7 Navigate to **Date format** or **Time format**.
- 8 Navigate to the format you want to use.
- 9 Press the **OK** key.

4.8.2 Change the temperature unit

Two temperature units are available.

- °C
- °F

When you change the temperature unit, temperatures are displayed in the selected unit. The temperature unit of results that were determined before you changed the unit remain unchanged.

Procedure

- 1 Press the **Menu** key.
- 2 Navigate to **Settings > Global units > Temperature unit**.
⇒ The **Temperature unit** window opens.
- 3 Navigate to the desired **Temperature unit**.
- 4 Press the **OK** key.
⇒ The temperatures are displayed in the selected unit.

4.8.3 Change the density unit

Three density units are available.

- g/cm³
- kg/m³
- lb/gal (US)

When you change the density unit, density values are displayed in the selected unit. There are two exceptions.

- The densities of results that were determined before you changed the unit remain unchanged.
- If you select the unit [lb/gal], the unit [g/cm³] is still used for adjustments and tests.

Procedure

- 1 Press the **Menu** key.
- 2 Navigate to **Settings > Global units > Density unit**.
⇒ The **Density unit** window opens.
- 3 Navigate to the desired **Density unit**.
- 4 Press the **OK** key.
⇒ The densities are displayed in the selected unit

4.8.4 Change energy saver settings

The settings of the parameters **Brightness**, **Energy saver** and **Auto shutdown** influence the power consumption and thus the battery life.

| Parameter | Description | Values |
|----------------------|---|----------------------------------|
| Brightness | Defines the brightness of the screen. | 10...100 % |
| Energy saver | Defines if the screen is dimmed when no action has been performed for a given time. | Off 30 60 90 120 seconds |
| Auto shutdown | Defines if the density meter is shut down when no action has been performed for a given time. | Off 2 5 10 minutes |

Procedure

- 1 Press the **Menu** key.
- 2 Navigate to **Settings > Screen**.
⇒ The **Screen** window opens.
- 3 Navigate to the desired parameter and change the settings.

4.8.5 Protect actions with a password

With the parameter **Password** you can prevent users from performing certain actions without a password. The following table shows which actions are password-protected.

| Action | Password protected |
|---|--------------------|
| Start methods. | No |
| Start tests. | No |
| Start adjustments. | Yes |
| View the configuration of methods, tests and adjustments. | No |
| Change the configuration of methods, tests and adjustments. | Yes |
| Create and delete methods. | Yes |
| View, print and export results. | No |
| Delete all results. | Yes |
| View the settings of the density meter. | No |
| Change the settings of the density meter. | Yes |
| Update the firmware. | Yes |
| Restore factory adjustment. | Yes |
| Restore factory settings. | Yes |

The password has to be entered once before a user performs a password-protected action and does not have to be reentered until the density meter is restarted.

If the user forgets the password, the universal password 8606 unlocks all actions and settings.

4.8.5.1 Enable the password protection

- 1 Press the **Menu** key.
- 2 Navigate to **Settings > Password > Password protection**.
⇒ The **Password protection** window opens.
- 3 Navigate to **Yes**.
- 4 Press the **OK** key.
⇒ The **Password** window opens.
- 5 Enter a password with the navigation joystick.
- 6 Press the **OK** key.
- 7 Reenter the password.
- 8 Press the **OK** key.
⇒ The password has to be entered before the user can perform a protected action.

4.8.5.2 Disable the password protection

- 1 Press the **Menu** key.
- 2 Navigate to **Settings > Password > Password protection**.
⇒ The **Password protection** window opens.
- 3 Navigate to **No**.
- 4 Press the **OK** key.
⇒ The **Password** window opens.
- 5 Enter the password with the navigation joystick.
- 6 Press the **OK** key.
⇒ Users can perform all actions.

4.8.5.3 Change the password

- 1 Disable the password protection.
- 2 Enable the password protection and enter the new password.

4.8.6 Activate and deactivate the auto rotation of the screen

The **Auto rotate** parameter defines whether the screen rotates by 180° when the density meter is placed on a bench.

- 1 Press the **Menu** key.
Navigate to **Settings > Screen > Auto rotate**.
⇒ The **Auto rotate** window opens.
- 3 Navigate to **Yes** to switch on or **No** to switch off the **Auto rotate** mode.
- 4 Press the **OK** key.
⇒ The screen rotates when the density meter is placed on a bench.

4.8.7 Activate and deactivate the audio signal

The parameter **Audio signal** defines whether an audio signal is played when a key or the navigation joystick is pressed and when measurements are finished.

- 1 Press the **Menu** key.
- 2 Navigate to **Settings > Audio signal**.
⇒ The **Audio signal** window opens.
- 3 Navigate to **Yes** to switch on or **No** to switch off the **Audio signal**.
- 4 Press the **OK** key.

4.8.8 Change the keyboard layout

- 1 Press the **Menu** key.
- 2 Navigate to **Settings > Language / Keyboard > Keyboard layout**.
⇒ The **Keyboard layout** window opens.
- 3 Navigate to the desired keyboard layout.
- 4 Press the **OK** key.

4.8.9 Change the language

The system language defines the language of the user interface and printouts.

- 1 Press the **Menu** key.
- 2 Navigate to **Settings > Language / Keyboard > Language**.
⇒ The **Language** window opens.
- 3 Navigate to the desired language.
- 4 Press the **OK** key.
⇒ The user interface is changed to the selected language.

4.8.10 Activate and deactivate a cleaning reminder

Because the measuring cell always contains residue from the last sample, there is a risk that the measuring cell can be damaged by the sample. To prevent such damages, EEPS recommends that you clean the measuring cell at the end of each sample series.

To remind users to clean the measuring cell, you can activate a reminder. This reminder is displayed before manual shutdown of the instrument, and users have to confirm or cancel the reminder before shutting down the density meter.

| Action of the system | Cleaning reminder | Auto shutdown |
|--|-------------------|---------------|
| When users shut down the density meter, a reminder is displayed. | Yes | No |
| If the density meter automatically shuts down, no reminder is displayed. | Yes | Yes |
| No reminder is displayed when the density meter shuts down. | No | Yes/No |

Procedure

- 1 Press the **Menu** key.
- 2 Navigate to **Settings > Measurement > Cleaning reminder**.
⇒ The **Cleaning reminder** window opens.
- 3 Navigate to **Yes** to activate or **No** to deactivate the **Cleaning reminder**.
- 4 Press the **OK** key.

See also

📖 Change energy saver settings } Page 18

4.9 Configure density determinations

Three different types of density determinations are available.

- **Methods:** determine the density of a sample.
- **Test:** determine the density of a standard to check that the measurement cell is clean and measuring accurately.
- **Adjustment:** determine the density of a standard and adjust the density meter based on the results.

4.9.1 Create, change or delete a method

4.9.1.1 Create a method

The new method is listed in the **Methods** window with the name you enter in the parameter **Method ID**. If you do not change the parameter **Method ID**, it is set by default to (A{X}{X}), e.g. A03.

- Less than 30 methods are saved.
 - The home screen is open.
- 1 Move the navigation joystick to the left.
⇒ The **Methods** window opens.
 - 2 Press the **New** key.
⇒ The **Method settings** window opens.
 - 3 Navigate to **Method ID** and enter a name with up to 25 characters.
 - 4 Press the **OK** key.
⇒ The method is listed in the **Methods** window.
 - 5 Change the parameters as needed.

See also

- 📖 Configure the user guidance } Page 23
- 📖 Configure the measurement reliability } Page 24
- 📖 Configure the result conversion } Page 24
- 📖 Configure the automatic documentation of results } Page 30
- 📖 Configure result limits } Page 32

4.9.1.2 Change a method

- The home screen is open.
- 1 Move the navigation joystick to the left.
 - ⇒ The **Methods** window opens.
- 2 Navigate to the method you want to edit.
 - ⇒ The **Method settings** window opens.
- 3 Change the parameters as needed.

See also

- 📖 Configure the user guidance } Page 23
- 📖 Configure the measurement reliability } Page 24
- 📖 Configure the result conversion } Page 24
- 📖 Configure the automatic documentation of results } Page 30
- 📖 Configure result limits } Page 32

4.9.1.3 Delete a method

- More than one method is created.
- The method you want to delete is not active, marked by a square.
- The home screen is open.
- 1 Move the navigation joystick to the left.
 - ⇒ The **Methods** window opens.
- 2 Navigate to the method you want to delete.
 - ⇒ The **Method settings** window opens.
- 3 Press the **Delete** key.
 - ⇒ The message **Do you want to delete the method?** is displayed.
- 4 Navigate to **Yes**.
- 5 Press the **OK** key.
 - ⇒ The method is no longer listed in the **Methods** window.

4.9.2 Change a test

- 1 Press the **Menu** key.
- 2 Navigate to **Test**.
 - ⇒ The **Test** window opens.
- 3 Change the parameters as needed.

See also

- 📖 Configure the user guidance } Page 23
- 📖 Configure the automatic documentation of results } Page 30
- 📖 Configure a standard } Page 32
- 📖 Configure the tolerance for a test } Page 33

4.9.3 Change an adjustment

- 1 Press the **Menu** key.
- 2 Navigate to **Adjustment**.
 - ⇒ The **Adjustment** window opens.
- 3 Change the parameters as needed.

See also

- Configure the user guidance } Page 23
- Configure the automatic documentation of results } Page 30
- Configure a standard } Page 32

4.9.4 Configure the user guidance

The parameters that are available to configure the user guidance are described in the following chapters.

4.9.4.1 Define the level of user guidance

The **Workflow** parameter defines the level of user guidance during the density determination. Two options are available.

- Manual:** users decide how and when to fill the measuring cell, start the measurement and drain or clean the measuring cell.
- Guided:** the density meter prompts the user to fill, drain or clean the measuring cell.

4.9.4.2 Define the pump speed

The parameter **Fill speed** defines the speed of the pump for filling the measuring cell. The sample viscosity places limits on the fill speed.

| Speed level | % of maximum pump speed | Fill time for water | Viscosity |
|-------------|-------------------------|---------------------|-----------------|
| High | 80 % | Approx. 4 s | Up to 40 mPa*s |
| Medium | 40 % | Approx. 8 s | Up to 75 mPa*s |
| Low | 10 % | Approx. 30 s | Up to 100 mPa*s |

4.9.4.3 Define the fill cycle (only guided workflow)

The parameter **Fill cycle** defines, how many times the measuring cell is filled and emptied before the density is measured. The sample that is in the measuring cell after the last filling is used for the measurement.

Recommendation:

- Density determination with the sample pump: set **Fill cycle** to 3.
- Density determination with a syringe: set **Fill cycle** to 2.

4.9.4.4 Define the cleaning type (only guided workflow)

Two types of cleaning methods are available, **Drain** and **Rinse**.

Drain

The user is prompted to drain the measuring cell after the measurement.

This setting is useful if the samples that are measured dissolve in each other.

Rinse

The user is prompted to fill and drain the measuring cell with a cleaning solution after the measurement. The parameter **Rinse cycle** defines how many times the user is prompted to fill and drain the measuring cell.

This setting is only useful if the samples that are measured do not dissolve in each other.

See also

- Typical phases of density determinations } Page 36

4.9.4.5 Activate and deactivate the confirmation of results

After the measurement reliability is achieved, the results are frozen. The parameter **Confirmation of results** defines whether users have to confirm the results before they are replaced by the current density value. Regardless of the setting, all results are stored.

The setting is not method specific but valid for all density determinations.

| Action of the system | Confirmation of results | Workflow |
|---|-------------------------|----------|
| The screen is frozen and the sample pump is locked until users confirm the result. | Yes | Guided |
| The screen is frozen until users confirm the result but the sample pump is not locked. | Yes | Manual |
| Users are prompted to place the filling tube into the waste beaker. As soon as users press OK , the result is replaced by the current density value. | No | Guided |
| As soon as the user starts draining the cell, the result is replaced by the current density value. | No | Manual |

Procedure

- 1 Press the **Menu** key.
- 2 Navigate to **Settings > Measurement > Confirmation of results**.
⇒ The **Confirmation of results** window opens.
- 3 Navigate to **Yes** to activate or **No** to deactivate the **Confirmation of results**.
- 4 Press the **OK** key.

See also

📖 Define the level of user guidance } Page 23

4.9.5 Configure the measurement reliability

Measurement reliability is only available for methods.

The parameter **Measurement reliability** defines how the stability of a measured value is evaluated. Once a measured value is determined to be stable, it is saved as a result.

- **Medium:** The result is saved as soon as the measured temperature value stays within 0.4 °C (0.72 °F) for 10 s. Results are delivered faster, but with less accuracy compared to the **High** mode.
- **High:** The result is saved as soon as the measured temperature value stays within 0.2 °C (0.36 °F) for 10 s. Results are very accurate, but may take a longer time compared to the **Medium** mode in cases where the sample temperature differs from the ambient temperature.
- **Manual** (only for unguided density determinations): users decide when the result is stable and save it.

See also

📖 Define the level of user guidance } Page 23

4.9.6 Configure the result conversion

The density meter converts the measured oscillation to the unit you define. The conversions are grouped in the following categories.

- **Density:** Density and specific gravity
- **Alcohol:** Alcohol concentration
- **API:** American Petroleum Institute (API density, API specific gravity, API degree)
- **Baumé:** Baumé scale
- **H2SO4:** Sulfuric acid concentration
- **Sugar:** Sucrose concentration

- **User-defined:** Conversion as defined by the user

Select the category and the conversion type

- 1 Press the **Menu** key.
 - 2 Navigate to **Methods > Method settings > Calculation > Category**
 - 3 Navigate to the desired category.
 - 4 Press the **OK** key.
 - ⇒ The **Calculation** window opens.
 - 5 Navigate to the conversion type you want to use.
 - 6 Press the **OK** key.
 - ⇒ The parameters that you need to configure for the selected conversion type are displayed.
- You can find more information about the conversion types and the parameters in the following chapters.

4.9.6.1 Density and specific gravity

Available conversions:

- **d:** density at the measurement temperature
- **d comp.:** temperature compensated density
- **SG:** temperature compensated specific gravity
- **SG (t/t):** specific gravity at the measurement temperature

Density at the measurement temperature

Unit: [g/cm³], [kg/m³] or [lb/gal (US)] as defined in **Settings > Global units**.

The calculation is based on a reference for the density of water.

Temperature compensated density

Unit: [g/cm³], [kg/m³] or [lb/gal (US)] as defined in **Settings > Global units**.

The measured density is converted to the value it would have at a compensation temperature. The following formula is used to compensate the temperature influence.

$$I_{HTRU} \cdot I_{RJFX} \cdot (1 + \alpha \cdot (9_{RJFX} - 9_{HTRU}))$$

- **d_{comp}:** temperature compensated density
- **d_{meas}:** density at the measurement temperature
- **α:** temperature coefficient as defined in **Alpha*1000 > Alpha entry**, see [Define the temperature-compensation coefficient **α**] Page 29]
- **T_{meas}:** measurement temperature, temperature of the measuring cell during the measurement
- **T_{comp}:** compensation temperature as defined in **Compensation temp.**

Temperature compensated specific gravity

$$SG, \frac{I_{HTRU}(8FRUQJ)}{I_{HTRU}(-24)}$$

- **SG:** specific gravity
- **d_{comp}(Sample):** density of the sample compensated to the temperature defined in **Compensation temp.**
 1. The temperature influence is compensated by the temperature coefficient **α** as defined in **Alpha*1000 > Alpha entry**. See [Define the temperature-compensation coefficient **α**] Page 29]
- **d_{comp}(H₂O):** density of water compensated to the temperature defined in **Compensation temp. 2**

Specific gravity at the measurement temperature

$$SG, (Y/Y) \cdot \frac{I(8FRUQJ)}{I(-24)}$$

- SG(t/t): specific gravity
- d(Sample): density of the sample at the measurement temperature.
- d(H₂O): density of water compensated to the measurement temperature.

See also

- 📖 Define the temperature-compensation coefficient α } Page 29
- 📖 Configure the result conversion } Page 24
- 📖 Density of pure water (0...40 °C) } Page 68
- 📖 Change the density unit } Page 18

4.9.6.2 Alcohol concentration

Available calculations:

- **Alcohol [%w/w]**: mass percent [%w/w]
- **Alcohol 60°F [%v/v]**: volume percent [%v/v], compensated to 60 °F
- **Alcohol 20°C [%v/v]**: volume percent [%v/v], compensated to 20 °C
- **Proof US 60°F [Proof]**: Proof degree with US unit [Proof], compensated to 60 °F
- **Proof IP 60°F [Proof]**: Proof degree with IP unit [Proof], compensated to 60 °F

See also

- 📖 Configure the result conversion } Page 24

4.9.6.3 American Petroleum Institute (API)

The conversion of the measured value to the selected unit is based on the tables published by the American Petroleum institute (API).

The following tables are available.

- **Crude oil (A)**
- **Refined products (B)**
- **Lubricants (D)**

The **Compensation temp.** parameter defines the compensation temperature.

The **Output format** defines to which of the following units the result is converted:

- **d**: API density
- **SG**: API specific gravity
- **°API**: API degree

See also

- 📖 Configure the result conversion } Page 24

4.9.6.4 Baumé scale

Unit: [°Bé]

Available conversions:

- **H. Bé 15°C [°Bé]**: for densities > 1 g/cm³, compensated to 15 °C
- **L. Bé 15°C [°Bé]**: for densities < 1 g/cm³, compensated to 15 °C
- **H. Bé 60°F [°Bé]**: for densities > 1 g/cm³, compensated to 60 °F
- **L. Bé 60°F [°Bé]**: for densities < 1 g/cm³, compensated to 60 °F

The temperature influence is compensated by the temperature coefficient α as defined in **Alpha*1000 > Alpha entry**.

See also

- Define the temperature-compensation coefficient α } Page 29
- Configure the result conversion } Page 24

4.9.6.5 Sulfuric acid concentration

Available conversions:

- H2SO4 [%w/w]**: mass percent [%w/w]
- H2SO4 20°C [%v/v]**: volume percent [%v/v], compensated to 20 °C

See also

- Configure the result conversion } Page 24

4.9.6.6 Sugar concentration

Available conversions:

- Brix [%w/w]**: mass percent [w/w %], compensated to 20 °C
- Plato [°P]**: degree Plato [°P], compensated to 20 °C

See also

- Configure the result conversion } Page 24

4.9.6.7 User defined concentration

You can define a function to convert a density or specific gravity to a concentration. The following steps are involved:

1. Define the conversion of the measured value to a density or specific gravity.
2. Define the function to convert the density or specific gravity to a concentration.
3. Define the unit and the number of decimal places of the concentration.

See also

- Define the density or specific gravity } Page 27
- Define the function } Page 28
- Define the format of the result } Page 29
- Configure the result conversion } Page 24

4.9.6.7.1 Define the density or specific gravity

The conversions are either based on temperature compensated densities (**d comp.**) or specific gravities (**SG**).

Define a temperature-compensated density

The following formula is used to calculate the temperature-compensated density.

$$d_{\text{HTRU}} = d_{\text{RJFX}} * (1 + \alpha * (9_{\text{RJFX}} - 9_{\text{HTRU}}))$$

- d_{comp} : temperature compensated density
- d_{meas} : density at the measurement temperature
- α : temperature coefficient as defined in **Alpha*1000 > Alpha entry**, see [Define the temperature-compensation coefficient α } Page 29]
- T_{meas} : measurement temperature, temperature of the measuring cell during the measurement
- T_{comp} : compensation temperature as defined in **Compensation temp.**

Steps to define a temperature-compensated density:

- The conversion category is set to **User-defined**.
- 1 Navigate to **X** and select one of the following options: **d comp.**, **d comp. - 1** or **(1/d comp.) - 1**.

- 2 Navigate to **Compensation temp.** and define the compensation temperature.
- 3 Navigate to **Alpha*1000 > Alpha entry** and define α . See [Define the temperature-compensation coefficient α } Page29]

Define a temperature-compensated specific gravity

The following formula is used to calculate the temperature-compensated specific gravity.

$$SG = \frac{d_{\text{HTRU}}(8FRUQJ)}{d_{\text{HTRU}}(-24)}$$

- SG: specific gravity
- $d_{\text{comp}}(\text{Sample})$: density of the sample compensated to the temperature defined in **Compensation temp. 1**. The temperature influence is compensated by the temperature coefficient α as defined in **Alpha*1000 > Alpha entry**. See [Define the temperature-compensation coefficient α } Page 29]
- $d_{\text{comp}}(\text{H}_2\text{O})$: density of water compensated to the temperature defined in **Compensation temp. 2**

Steps to define the temperature-compensated specific gravity:

- The conversion category is set to **User-defined**.
- 1 Navigate to **X** and select one of the following options: **SG**, **SG-1** or **(1/SG)-1**.
 - 2 Navigate to **Compensation temp. 1** and define the compensation temperature for the sample.
 - 3 Navigate to **Compensation temp. 2** and define the compensation temperature for water.
 - 4 Navigate to **Alpha*1000 > Alpha entry** and define α . See [Define the temperature-compensation coefficient α } Page29]

See also

 Define the function } Page 28

4.9.6.7.2 Define the function

You can either use a linear function (**Linear (Ax+B)**) or a second order polynomial function (**2nd order pol. (ax²+bx+c)**). The functions are based on a graph with the density or specific gravity on the x-axis and the concentration on the y-axis.

The following formulae are used.

- Linear function: $Ax + B$
- Second order polynomial function: $Ax^2 + Bx + C$

Procedure

- The coefficients A and B are known for a linear function.
 - The coefficients A, B and C are known for a second order polynomial function.
- 1 Navigate to **Fit type** and select **Linear (Ax+B)** or **2nd order pol. (ax²+bx+c)**.
 - 2 Press the **OK** key.
 - 3 Enter the values for the coefficients.

Calculate the coefficients A, B and C

- 1 If you want to use a second order polynomial function, prepare at least 4 solutions with different concentrations.
- 2 If you want to use a linear function, prepare at least 2 solutions with different concentrations.
- 3 Determine the density or specific gravity you want to use for each concentration.
- 4 Plot the concentration (y-axis) against the density or specific gravity (x-axis).
- 5 Fit a line or second order polynomial to the curve.

See also

 Define the density or specific gravity } Page 27

4.9.6.7.3 Define the format of the result

Using the parameters **Unit** and **Decimal places**, you can define the unit and the number of decimal places for the display of the current value and the result.

4.9.6.8 Define the temperature-compensation coefficient α

The temperature-compensation coefficient α is used to convert a measured value to a reference temperature. You have three options to define α .

- **Manual:** users enter the value for α that they calculated or read from a table.
- **Calculated:** the density meter calculates α based on a linear equation and densities and temperatures that users enter.
- **2nd order pol. ($\alpha x^2 + bx + c$):** the density meter calculates α based on a second order polynomial using coefficients that users enter.

See also

📖 Density and specific gravity } Page 25

📖 Baumé scale } Page 26

📖 Define the density or specific gravity } Page 27

4.9.6.8.1 Enter a known value for α

- The result of $\alpha \cdot 1000$ is known.
- 1 Navigate to **Alpha*1000** > **Alpha entry** and select **Manual**.
 - 2 Press the **OK** key.
 - 3 Navigate to **Alpha*1000**.
 - 4 Enter the value for $\alpha \cdot 1000$.
 - 5 Press the **OK** key.

Calculate α

- 1 Measure the density (d_1) at a temperature (T_1) above the normal measuring temperature.
- 2 Measure the density (d_2) at a temperature (T_2) below the normal measuring temperature.
- 3 Use the measured densities and the temperatures in [°C] to calculate α according to the following formula.
$$\alpha = \frac{d_2 - d_1}{T_1 - T_2} \cdot 1000$$
- 4 Calculate the result of $\alpha \cdot 1000$.

Example

Density at 26 °C (T_1) = 0.7844 g/cm³

Density at 15 °C (T_2) = 0.7937 g/cm³

$$\alpha = \frac{0.7937}{0.7844} - 1) / (26 - 15)$$

$$\alpha = ((1.011856 - 1) / 11) = 0.011856 / 11 = 0.001078$$

$$\alpha \cdot 1000 = 1.078$$

See also

📖 Temperature-compensation coefficients α } Page 68

4.9.6.8.2 The density meter calculates a fixed value for α

- The density (d_1) at a temperature (T_1) above the normal measuring temperature is known.
 - The density (d_2) at a temperature (T_2) below the normal measuring temperature is known.
- 1 Navigate to **Alpha*1000** > **Alpha entry** and select **Calculated**.
 - 2 Navigate to **Density 1** and enter the value for d_1 .
 - 3 Navigate to **Temperature 1** and enter the value for T_1 .

- 4 Navigate to **Density 2** and enter the value for d_2 .
 - 5 Navigate to **Temperature 2** and enter the value for T_2 .
- ⇒ The density meter calculates the value for **Alpha*1000** and displays it.

See also

📖 List of errors and problems } Page 57

4.9.6.8.3 Define the second order polynomial used to calculate α

The density meter can use the following second order polynomial to calculate α .

$$\rho = (F \cdot I_{RJFX}^2 + G \cdot I_{RJFX} + H)$$

Procedure

- The three coefficients a, b and c are known.
- 1 Navigate to **Alpha*1000 > Alpha entry** and select **2nd order pol. (ax²+bx+c)**.
 - 2 Press the **OK** key.
 - 3 Enter the values for the coefficients a, b and c.

Calculate the coefficients a, b and c

- 1 Prepare at least 4 solutions with different concentrations.
- 2 Define two temperatures, one above and one below the normal measurement temperature.
- 3 Measure the density of each solution at both temperatures.
- 4 Calculate the temperature-compensation coefficient α for each solution.
- 5 Plot the values for α (y-axis) against the densities (x-axis) measured at one of the temperatures.
- 6 Fit a second order polynomial to the curve.

See also

📖 List of errors and problems } Page 57

4.9.7 Configure the automatic documentation of results



NOTICE

Loss of data!

A maximum of 1100 results is saved in the density meter. When the result list contains 1100 results and a new results is saved, the oldest result is overwritten.

- Print or export the results before the maximum number of results is reached.

See also

- 📖 Change a method } Page 22
- 📖 Change a test } Page 22
- 📖 Change an adjustment } Page 22

4.9.7.1 Configure the sample or standard identification

You can define what kind of identification is assigned to a sample or to a standard.

Automatic numbering is only available for methods.

| Action of the system | Sample ID entry Standard ID entry | Sample ID Standard ID |
|--|--------------------------------------|--------------------------|
| No identification is assigned to the sample or the standard. | None | Not available |

| Action of the system | Sample ID entry Standard ID entry | Sample ID Standard ID |
|---|--------------------------------------|--------------------------|
| <ul style="list-style-type: none"> The identification you define in the Sample ID parameter is assigned to all samples measured with the same method. The identification you define in the Standard ID parameter is assigned to all standards measured with the same test. | Fixed | 0...25 characters |
| <p>Users enter the identification before the density measurement starts.</p> <ul style="list-style-type: none"> Guided density determination: users are prompted to enter the identification when the method starts. The density determination continues when the user has entered a valid identification. Unguided density determination: Users have to enter the identification before the measurement starts but are not prompted to do so. If they do not enter an identification, the identification of the previous sample is used. | Variable | Not available |
| An automatically generated identification is assigned to the sample. The identification automatically increases by 1, when a new measurement is started with the same method. | Automatic numbering | Not available |

4.9.7.2 Configure the automatic printing of results

The **Printout** parameter defines whether a result is automatically printed when it is saved and which information is printed.

- **None:** No report is printed.
- **Short:** A short report is printed.
- **Long:** A long report is printed

| Information | Methods | Test | Adjustment |
|--------------------------------|-------------------|-------------------|-------------------|
| Date / Time | Short/Long | Short/Long | Short/Long |
| Method ID | Short/Long | – | – |
| Sample ID | Short/Long | – | – |
| Application name with standard | – | Short/Long | Short/Long |
| Standard ID | – | Short/Long | Short/Long |
| Status | Short/Long | Short/Long | – |
| Calculation | Short/Long | – | – |
| Density | Short/Long | Short/Long | Short/Long |
| Dev. d | – | Short/Long | Short/Long |
| Temp. | Short/Long | Short/Long | Short/Long |
| d nominal | – | Short/Long | Short/Long |
| SNR | Long | Long | Long |

| Information | Methods | Test | Adjustment |
|---|---------|------|------------|
| Additional settings like the compensation temperature and the temperature-compensation coefficient α | Long | Long | Long |

See also

📖 Connect a printer } Page 15

4.9.7.3 Configure the automatic export of results

Results are automatically exported to EasyDirect Density & Refractometry if the density meter is connected to a computer with the software installed.

See also

📖 Connect to EasyDirect Density & Refractometry } Page 17

4.9.8 Configure result limits

Result limits are only available for methods.

The **Result limits** parameter defines whether the density meter evaluates if a result lies within a defined range. The parameters **Lower limit** and **Upper limit** define the range.

- Result within the limits: the background of the measuring ribbon turns green.
- Result outside the limits: the background of the measuring ribbon turns red and the text **Out of limits** is displayed in the sampling ribbon

Procedure

- 1 Press the **Menu** key.
- 2 Navigate to **Methods > Method settings > Calculation > Result limits**.
- 3 To deactivate **Result limits**, navigate to **No**.
- 4 To activate **Result limits**, navigate to **Yes**.
- 5 Press the **OK** key.
 - ⇒ **Lower limit** and **Upper limit** are displayed.
- 6 Set the **Lower limit** and **Upper limit**.

4.9.9 Configure a standard

Use water as standard

- The **Test** window or the **Adjustment** window are open.
- 1 Navigate to **Standard type** and select **Water**.
 - 2 Press the **OK** key.
- ⇒ The density meter uses predefined values for the **Test** or the **Adjustment**.

Use another substance as standard

- The **Test** window or the **Adjustment** window are open.
- 1 Navigate to **Standard type** and select **Other standard**.
 - 2 Press the **OK** key.
 - 3 Navigate to **Compensation temp.** and enter the compensation temperature.
 - 4 Navigate to **d nominal** and enter the nominal density of the standard at the temperature you entered as compensation temperature.
 - 5 Navigate to **Alpha*1000** and define the temperature-compensation coefficient α .

See also

📖 Define the temperature-compensation coefficient α } Page 29

4.9.10 Configure the tolerance for a test

The **Tolerance d** parameter is used to evaluate the measured density and decide if the test passed or failed.

Recommendations for defining the value for **Tolerance d**:

- Deionized water: $2 * (\text{instrument resolution} + \text{operator repeatability})$
- Certified organic standards with a high temperature-compensation coefficient: uncertainty of the standard + limit of error of instrument + temperature error + $2 * \text{operator repeatability}$

The operator repeatability is the standard deviation of ten density determinations performed by the operator.

5 Operation

5.1 Start up the density meter

- Press key 1 (1).
 - ⇒ A short beep is played.
 - ⇒ A welcome message is displayed.
- ⇒ The home screen opens. The density meter is ready to use.

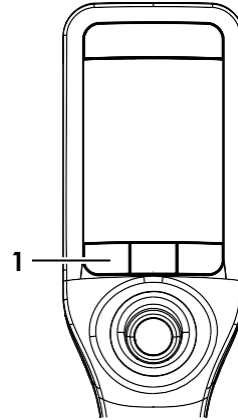

5.2 Shut down the density meter

- Press and hold any of the keys or the navigation joystick for more than 3 s.
 - ⇒ A beep is played and the screen goes dark.
- ⇒ The control circuits for the keys and the navigation joystick are energized. The rest of the density meter is no longer energized.

Shut down using the Menu

- The home screen is open.
 - 1 Press the **Menu** key.
 - 2 Navigate to **Shut down**.
 - ⇒ The dialog **Do you want to shut down the instrument?** opens.
 - 3 Press the **Yes** key.
 - ⇒ A beep is played and the screen goes dark.
- ⇒ The control circuits for the keys and the navigation joystick are energized. The rest of the density meter is no longer energized.

See also

- 📖 Activate and deactivate a cleaning reminder } Page 20

5.3 Navigate and enter information

5.3.1 Navigate through menus and confirm settings

- 1 Press the **Menu** key.
- 2 To navigate to a desired menu, move the navigation joystick up or down.
- 3 To navigate to a submenu of the selected menu, move the navigation joystick to the right.
- 4 To go back, move the navigation joystick to the left.

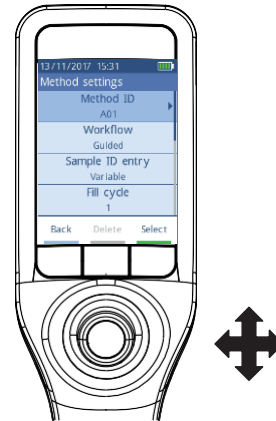

Confirm settings

In every menu, where the function of key 3 is marked with a green bar, you can press the navigation joystick to confirm the selection.

Shortcut to the method list

- The home screen is open.
- Move the navigation joystick to the left.
- ⇒ The **Methods** window opens.

5.3.2 Enter text and numbers

- The keyboard window is open.
- 1 Navigate to the character, number, symbol or icon.
 - 2 Press the navigation joystick to confirm the selection of the character, number, symbol or icon.
 - 3 To confirm the entered information and leave the keyboard window, press the **OK** key.

Keyboard overview

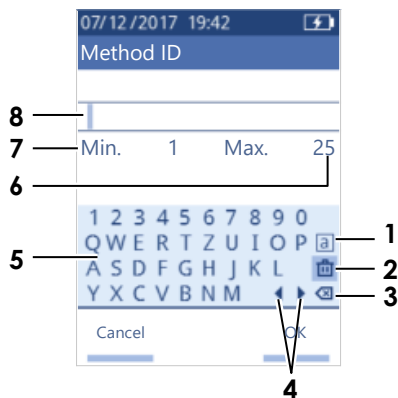

| No. | Icon | Function |
|-----|------|---|
| 1 | | Cycles between the screens with small, capital or special characters. |
| 2 | | Deletes all entered characters. |
| 3 | | Deletes the character to the left of the cursor. |

| No. | Icon | Function |
|-----|------|---|
| 4 | ◀ ▶ | Moves the cursor. |
| 5 | – | Displays available characters, numbers and symbols. |
| 6 | – | Maximum number of characters you can enter. |
| 7 | – | Minimum number of characters you need to enter. |
| 8 | – | Displays the entered characters. |

See also

📖 Change the keyboard layout } Page 20

5.4 Typical phases of density determinations

Density determinations include the following two phases.

- Fill the measuring cell with sample and perform the measurement.
- Prepare the measuring cell for the next sample.

5.4.1 Fill the measuring cell and measure the density

Because the measuring cell always contains residue from the previous sample or the cleaning solution, it is important that you remove the residue using the new sample. This is only possible if the residue is soluble in the new sample.

To achieve good results, make sure that the measuring cell contains only the sample you want to measure and that there are no bubbles in the measuring cell.

You can use the sample pump or syringes to fill, drain and rinse the measuring cell. The sample pump is used for samples with a viscosity up to 100 mPa*s. Syringes are typically used if the viscosity of the samples is above 100 mPa*s.

See also

📖 Example: Density determination using the sample pump } Page 36

📖 Example: Density determination using a syringe } Page 39

📖 Example: Density determination of cold or hot samples } Page 42

5.4.2 Prepare the measuring cell for the next sample

At the end of this phase, the residue in the measuring cell must be soluble in the next sample. The solubility of the sample defines if you can drain the measuring cell or if you need to rinse it.

Drain

If the next sample dissolves the sample you just measured, you can drain the cell.

Rinse

If the next sample does not dissolve the sample you just measured, you have to rinse the measuring cell with a cleaning solution. The cleaning solution must dissolve the sample that you just measured and the next sample. When you rinse the measuring cell, the cleaning solution removes the residue from the original sample.

See also

📖 Clean the measuring cell } Page 50

5.5 Example: Density determination using the sample pump

The following chapters show you how to configure and perform a density determination of deionized water at room temperature (23 °C or 73.4 °F).

Summary of the configuration

- Guided density determination
- Filling and draining with the sample pump
- Evaluation if result lies within specified limits

You can find more information about the configuration of a method in the chapter [Configure density determinations } Page 21].

5.5.1 Configure the method

- The density unit is set to [g/cm³].
 - **Confirmation of results** in **Settings** is activated.
 - The home screen is open.
- 1 Move the navigation joystick to the left.
⇒ The **Methods** window opens.
 - 2 Press the **New** key.
⇒ The **Method settings** window opens.
 - 3 Navigate to **Method ID** and enter a name with up to 25 characters.
 - 4 Press the **OK** key.
⇒ The method is listed in the **Methods** window.
 - 5 Change the parameter settings to the values shown in the following table.

| Parameter | Setting | Explanation |
|---------------------------------------|--------------------------|--|
| Workflow | Guided | The density meter prompts users to fill and drain the measuring cell. |
| Sample ID entry | Variable | The density meter prompts users to enter the sample ID before the density is measured. |
| Fill cycle | 3 | The density meter prompts users to fill and drain the measuring cell twice and then fill the measuring cell for the measurement. |
| Fill speed | High | The pump fills the measuring cell with 80 % of the maximum pump speed. |
| Measurement reliability | Medium | The result is saved as soon as the measured temperature value stays within 0.4 °C (0.72 °F) for 10 s. |
| Calculation > Category | Density | A density is calculated. |
| Calculation > Calculation | d | The density is not compensated to a certain temperature. |
| Calculation > Result limits | Yes | The density meter evaluates if the result is within a defined range. |
| Lower limit | 0.9972 g/cm ³ | Defines the lower limit of the range. |
| Upper limit | 0.9977 g/cm ³ | Defines the upper limit of the range. |
| Clean | Drain | Users are prompted to drain the measuring cell. |
| Printout | None | The result is not printed. |

See also

- 📖 Change the density unit } Page 18
- 📖 Activate and deactivate the confirmation of results } Page 24
- 📖 Configure density determinations } Page 21

5.5.2 Perform the density determination

Start the method

- The density meter is set up to work with the sample pump.
 - The piston is in the lowermost position.
 - The home screen is open.
- 1 Move the navigation joystick to the left.
 - 2 Navigate to the method you want to use and press the **Start** key.
 - ⇒ The home screen opens.
 - 3 Press the **Start** key.
 - ⇒ The **Sample ID** window opens.
 - 4 Enter the identification.
 - 5 Press the **OK** key.

Rinse the measuring cell

- 1 Immerse the filling tube into the sample (1).
- 2 Press the **OK** key.
 - ⇒ The sample pump starts and stops when the piston is in the uppermost position.
- 3 Hold the filling tube over the waste beaker (2).
- 4 Press the **OK** key.
 - ⇒ The sample pump starts and stops when the piston is in the lowermost position.
- 5 Clean the end of the filling tube with a clean tissue.
- 6 Repeat the steps once.

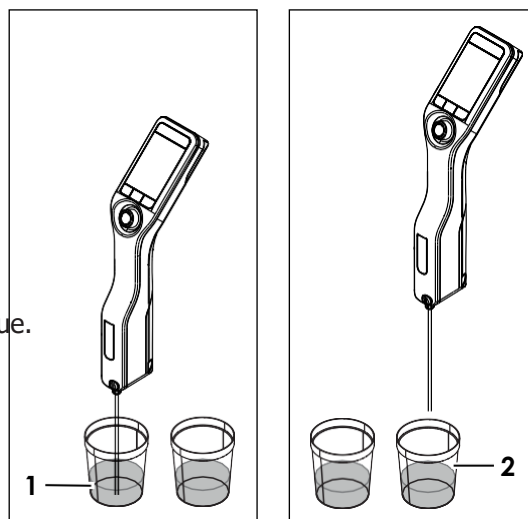

Fill the measuring cell and measure the density

- 1 Immerse the filling tube into the sample (1).
- 2 Press the **OK** key.
 - ⇒ The sample pump starts and stops when the piston is in the uppermost position.
- 3 Make sure there are no bubbles in the measuring cell.
 - ⇒ The measurement starts.
 - ⇒ When the background of the measuring ribbon changes color, the measurement is finished.
 - ⇒ The measured value is saved in the results.
- 4 Press the **OK** key.

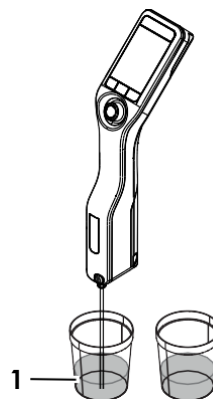

Drain the measuring cell

- 1 Hold the filling tube over the waste beaker (1).
- 2 Press the **OK** key.
⇒ The sample pump starts and stops when the piston is in the lowermost position.
- 3 Clean the end of the filling tube with a clean tissue.

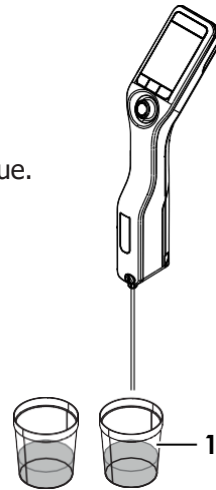

5.6 Example: Density determination using a syringe

The following chapters show you how to configure and perform a density determination of a viscous sample such as 40 % w/w sugar solution at room temperature (23 °C or 73.4 °F).

Summary of the configuration

- Guided density determination
- Filling and draining with a syringe

You can find more information about the configuration of a method in the chapter [Configure density determinations } Page 21].

5.6.1 Configure the method

- **Confirmation of results** in **Settings** is activated.
 - The home screen is open.
- 1 Move the navigation joystick to the left.
⇒ The **Methods** window opens.
 - 2 Press the **New** key.
⇒ The **Method settings** window opens.
 - 3 Navigate to **Method ID** and enter a name with up to 25 characters.
 - 4 Press the **OK** key.
⇒ The method is listed in the **Methods** window.
 - 5 Change the parameter settings to the values shown in the following table.

| Parameter | Setting | Explanation |
|--------------------------------|-----------------|---|
| Workflow | Guided | The density meter prompts users to fill and drain the measuring cell. |
| Sample ID entry | Variable | The density meter prompts users to enter the sample ID before the density is measured. |
| Fill cycle | 2 | The density meter prompts users to rinse the measuring cell and then fill the measuring cell for the measurement. |
| Fill speed | High | Has no effect because the syringe mode is activated. |
| Measurement reliability | Medium | The result is saved as soon as the measured temperature value stays within 0.4 °C (0.72 °F) for 10 s. |

| Parameter | Setting | Explanation |
|-----------------------------|-------------|--|
| Calculation > Category | Sugar | A sugar concentration is calculated. |
| Calculation > Calculation | Brix [%w/w] | A Brix value is calculated. |
| Calculation > Result limits | None | The density meter does not evaluate if the result is within a defined range. |
| Clean | Drain | Users are prompted to drain the measuring cell. |
| Printout | None | The result is not printed. |

See also

☰ Activate and deactivate the confirmation of results } Page 24

5.6.2 Perform the density determination

Start the method

- The density meter is set up to work with a syringe.
 - The measuring cell is drained.
 - The home screen is open.
- 1 Move the navigation joystick to the left.
 - 2 Navigate to the method you want to use and press the **Start** key.
 - ⇒ The home screen opens.
 - 3 Press the **Start** key.
 - ⇒ The **Sample ID** window opens.
 - 4 Enter the identification.
 - 5 Press the **OK** key.

Rinse the measuring cell

- 1 Fill a new syringe with sample.
- 2 Insert the syringe into the connector for the syringe.

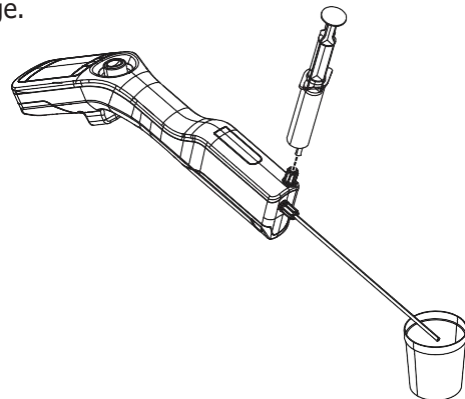

- 3 Hold the filling tube over the waste beaker (1).
- 4 Press the syringe plunger continuously into the syringe.
 - ⇒ The sample flows through the measuring cell and removes the residue from the previous sample.
- 5 Pull the plunger continuously out of the syringe.
 - ⇒ The sample is pulled back into the syringe and the measuring cell fills with air.
- 6 Remove the syringe and empty it into a suitable waste beaker.

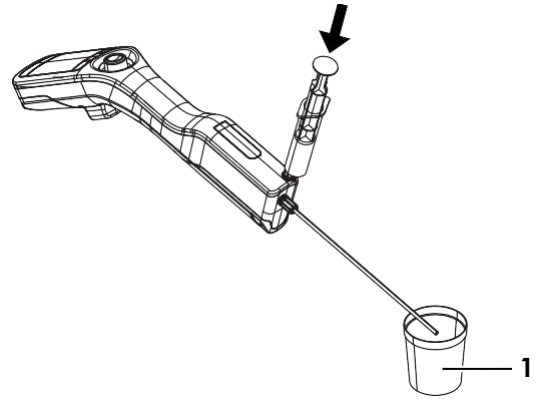

Fill the measuring cell and measure the density

- 1 Fill a new syringe with sample.
- 2 Insert the syringe into the connector for the syringe.

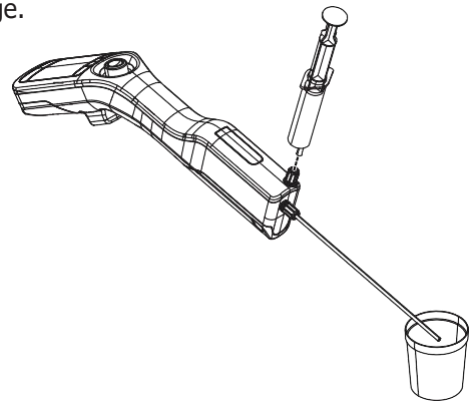

- 3 Hold the filling tube over the waste beaker (1).
- 4 Press the syringe plunger slowly (5...10 cm/s) and continuously into the syringe until only a small amount of sample is left in the syringe.
 - ⇒ The sample flows with a laminar flow into the measuring cell.
- 5 Leave the syringe in the connector.
- 6 Make sure there are no bubbles in the measuring cell.
- 7 Press the **OK** key.
 - ⇒ The measurement starts.
 - ⇒ When the background of the measuring ribbon changes color, the measurement is finished.
 - ⇒ The measured value is saved in the results.
- 8 Press the **OK** key.

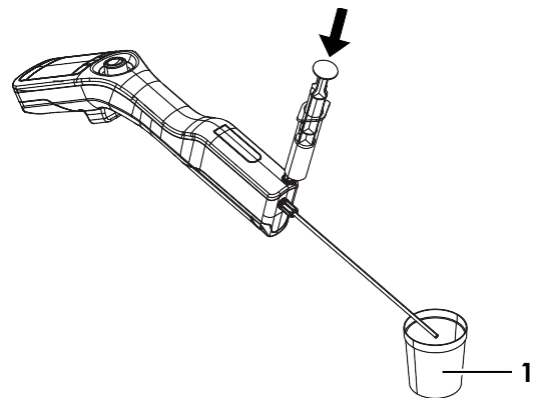

Drain the measuring cell

- 1 Pull the plunger continuously out of the syringe.
⇒ The sample is pulled back into the syringe and the measuring cell fills with air.
- 2 Remove the syringe and empty it into a suitable waste beaker.

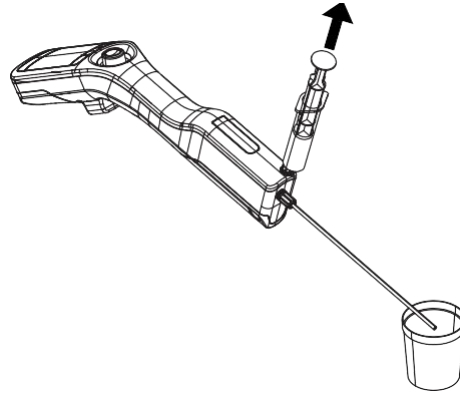

5.7 Example: Density determination of cold or hot samples

To achieve good results, the measuring cell and the sample must have the same temperature. If you fill the measuring cell with a sample that is more than 5 °C (9 °F) above or below the temperature displayed on the home screen, this condition is not met. Because the density meter has no active temperature control, you must wait until the temperature of the measuring cell and the temperature of the sample are the same, before you make the measurement.

The following chapters show you how to configure and perform a density determination of deionized water that is more than 5 °C (9 °F) above or below the temperature displayed on the home screen.

Summary of the configuration

- Unguided density determination
- Filling and draining with the sample pump

You can find more information about the configuration of a method in the chapter [Configure density determinations } Page 21].

5.7.1 Configure the method

- The density unit is set to [g/cm³].
 - **Confirmation of results** in **Settings** is activated.
 - The home screen is open.
- 1 Move the navigation joystick to the left.
⇒ The **Methods** window opens.
 - 2 Press the **New** key.
⇒ The **Method settings** window opens.
 - 3 Navigate to **Method ID** and enter a name with up to 25 characters.
 - 4 Press the **OK** key.
⇒ The method is listed in the **Methods** window.
 - 5 Change the parameter settings to the values shown in the following table.

| Parameter | Setting | Explanation |
|--------------------------------|-----------------|---|
| Workflow | Manual | Users define their individual measuring workflows. |
| Sample ID entry | Variable | Users need to enter the identification before they start the measurement. |
| Fill speed | High | The pump fills the measuring cell with 80 % of the maximum pump speed. |
| Measurement reliability | Medium | The result is saved as soon as the measured temperature value stays within 0.4 °C (0.72 °F) for 10 s. |

| Parameter | Setting | Explanation |
|-----------------------------|---------|--|
| Calculation > Category | Density | A density is calculated. |
| Calculation > Calculation | d | The density is not compensated to a certain temperature. |
| Calculation > Result limits | None | The density meter does not evaluate if the result is within a defined range. |
| Clean | Drain | Users are prompted to drain the measuring cell. |
| Printout | None | The result is not printed. |

See also

☰ Activate and deactivate the confirmation of results } Page 24

5.7.2 Perform the density determination

Start the method

- The density meter is set up to work with the sample pump.
 - The piston is in the lowermost position.
 - The home screen is open.
- 1 Move the navigation joystick to the left.
 - 2 Navigate to the method you want to use and press the **Start** key.
⇒ The home screen opens.
 - 3 To enter a **Sample ID**, move the navigation joystick to the right.
⇒ The **Sample ID** window opens.
 - 4 Enter the identification.
 - 5 Press the **OK** key.

Rinse the measuring cell

- 1 Immerse the filling tube into the sample (1).
- 2 Move the navigation joystick upwards and let go.
⇒ The sample pump starts and stops when the piston is in the uppermost position.
- 3 Hold the filling tube over the waste beaker (2).
- 4 Move the navigation joystick downwards and let go.
⇒ The sample pump starts and stops when the piston is in the lowermost position.
- 5 Clean the end of the filling tube with a clean tissue.
- 6 Repeat the steps once.

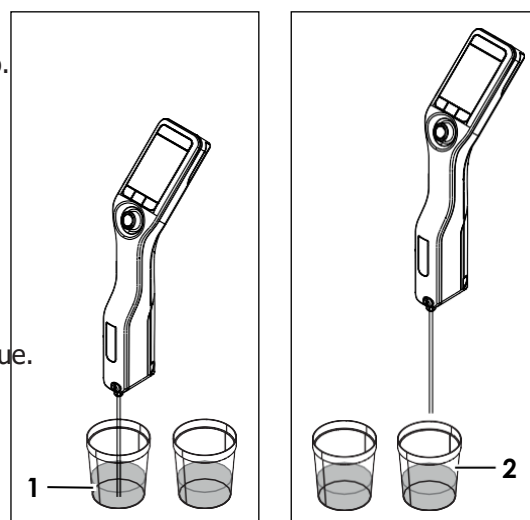

Fill the measuring cell and measure the density

- 1 Immerse the filling tube into the sample (1).
- 2 Move the navigation joystick upwards and let go.
 - ⇒ The sample pump starts and stops when the piston is in the uppermost position.
- 3 Make sure there are no bubbles in the measuring cell.
- 4 Press the **Start** key.
 - ⇒ The measurement starts.
 - ⇒ When the background of the measuring ribbon changes color, the measurement is finished.
 - ⇒ The measured value is saved in the results.
- 5 Press the **OK** key.
- 6 Wait for about 20 seconds and press the **Start** key again.
 - ⇒ The sample that is still in the measuring cell is measured again.
- 7 Tap **Results** and compare the last two results.
- 8 Tap **Back**.
- 9 If the results are not the same, continue to measure the same sample until the temperatures and the results of two measurements in a row are the same.

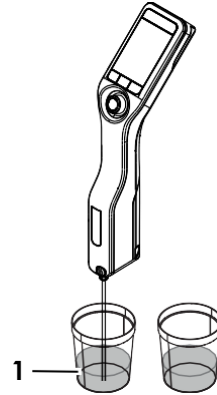

Drain the measuring cell

- 1 Hold the filling tube over the waste beaker (1).
- 2 Move the navigation joystick downwards and let go.
 - ⇒ The sample pump starts and stops when the piston is in the lowermost position.
- 3 Clean the end of the filling tube with a clean tissue.

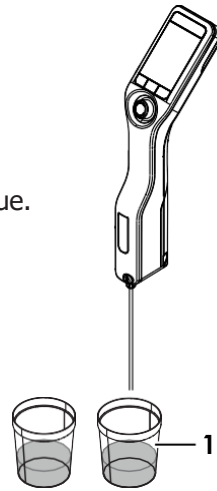

5.8 Read and write information with the RFID reader (DensitoPro only)

With the RFID reader, you can read or write identifications for samples or standards to Smart Tags. The RFID reader only recognizes the following characters.

- A-Z
- a-z
- 0-9

Metal containers interfere with reading and writing to Smart Tags. For this reason you need to place the Smart Tag (1) on a SmartSample film (2).



See also

📖 Miscellaneous accessories } Page 66

5.8.1 Write information to a Smart Tag

- The RFID reader is activated.
 - METTLER TOLEDO Smart Tags are available.
- 1 Press the **Menu** key.
 - 2 Navigate to **Settings > RFID / Barcode > Write ID to RFID tag**.
 - ⇒ The icon  is displayed in the status ribbon.
 - 3 Enter the identification.
 - 4 Hold the RFID reader over a Smart Tag and press the **Write** key.
 - ⇒ An audio signal is played and the notification **RFID tag is written** is displayed.
- ⇒ The identification is saved on the Smart Tag.

See also

📖 Activate and deactivate the RFID reader (DensitoPro only) } Page 13

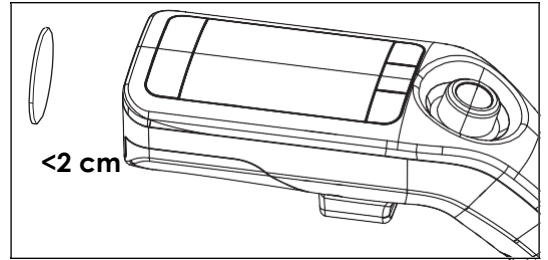

5.8.2 Read information from a Smart Tag

Enter the identification of a sample or a standard

- The RFID reader is activated.
 - The parameter **Sample ID entry** or **Standard ID entry** is set to **Variable**.
- When you are prompted to enter an identification, press the **RFID** key and hold the RFID reader over the Smart Tag.
- ⇒ An audio signal is played and the identification is saved.

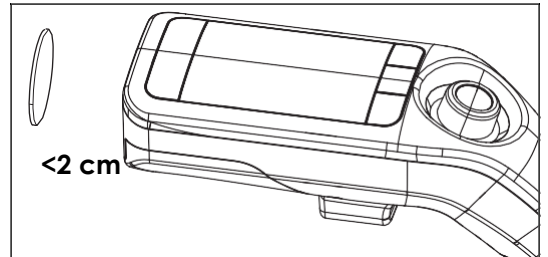

Read information from a Smart Tag

- The RFID reader is activated.
- 1 Press the **Menu** key.
 - 2 Navigate to **Settings > RFID / Barcode > Scan RFID tag**.
 - ⇒ The notification **Scan RFID tag** is displayed.
 - 3 Hold the RFID reader over a Smart Tag and wait until an audio signal is played.
- ⇒ The read information is displayed.

See also

📖 Activate and deactivate the RFID reader (DensitoPro only) } Page 13

📖 Configure density determinations } Page 21

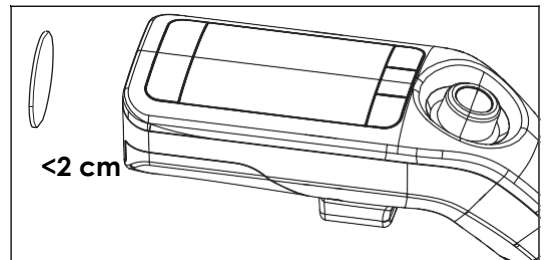

5.9 Read information with the barcode reader (DensitoPro only)

With the barcode reader, you can read identifications for samples and standards from linear barcodes.

The barcode reader only recognizes the following characters.

- A-Z
- a-z
- 0-9

Procedure

- The barcode reader is activated.
 - The parameter **Sample ID entry** or **Standard ID entry** is set to **Variable**.
 - When you are prompted to enter an identification, press the **Barcode** key and hold the barcode reader over the barcode.
- ⇒ An audio signal is played and the identification is saved.

See also

 Activate and deactivate the barcode reader (DensitoPro only) } Page 13

 Configure density determinations } Page 21

5.10 View, export, print and delete results

5.10.1 View results

- The home screen is open.
- 1 Press the **Results** key.
 - ⇒ A list with all results is displayed.
 - 2 To view an individual result, navigate to the result and move the navigation joystick to the right.

5.10.2 Delete all results

You can only delete all results but not individual results or a subgroup of results.

- The home screen is open.
- 1 Press the **Results** key.
 - 2 Press the **Delete** key.
 - ⇒ The message **Do you want to delete all results?** is displayed.
 - 3 Press the **Yes** key.
- ⇒ An empty list is displayed.

5.10.3 Export and print results



NOTICE

Loss of data!

A maximum of 1100 results is saved in the density meter. When the result list contains 1100 results and a new results is saved, the oldest result is overwritten.

- Print or export the results before the maximum number of results is reached.

You can export or print results if you have the required accessories.

- To export results you need the EasyDirect Density & Refractometry software.
- To print results, you need a compatible USB printer or bluetooth printer.

See also

- 📖 Accessories } Page 65
- 📖 Connect to EasyDirect Density & Refractometry } Page 17
- 📖 Connect a printer } Page 15

5.10.3.1 Export results to EasyDirect Density & Refractometry

Export an individual result

- EasyDirect Density & Refractometry is connected.
 - An individual result is displayed.
- 1 Press the **Report** key.
 - 2 Navigate to **Option** and select **EasyDirect**.
 - 3 Press the **OK** key.
 - 4 Press the **Start** key.
- ⇒ The export is completed and the result is displayed.

Export all results or a subset of results

- EasyDirect Density & Refractometry is connected.
 - The result list is displayed.
- 1 Press the **Report** key.
 - 2 Navigate to **Option** and select **EasyDirect**.
 - 3 Press the **OK** key.
 - 4 To export all results, deactivate the filter.
 - 5 To export a subset of results, configure the filter.
 - 6 Press the **Start** key.
- ⇒ The export is completed and the result list is displayed.

See also

- 📖 Configure the filter } Page 48
- 📖 Connect to EasyDirect Density & Refractometry } Page 17

5.10.3.2 Print results

The **Printout** parameter defines whether a result is automatically printed when it is saved and which information is printed.

| Information | Methods | Test | Adjustment |
|--------------------------------|------------|------------|------------|
| Date / Time | Short/Long | Short/Long | Short/Long |
| Method ID | Short/Long | – | – |
| Sample ID | Short/Long | – | – |
| Application name with standard | – | Short/Long | Short/Long |
| Standard ID | – | Short/Long | Short/Long |
| Status | Short/Long | Short/Long | – |
| Calculation | Short/Long | – | – |
| Density | Short/Long | Short/Long | Short/Long |
| Dev. d | – | Short/Long | Short/Long |
| Temp. | Short/Long | Short/Long | Short/Long |
| d nominal | – | Short/Long | Short/Long |
| SNR | Long | Long | Long |

| Information | Methods | Test | Adjustment |
|---|---------|------|------------|
| Additional settings like the compensation temperature and the temperature-compensation coefficient α | Long | Long | Long |

Print an individual result

- A printer is connected.
 - An individual result is displayed.
- 1 Press the **Report** key.
 - 2 Navigate to **Option** and select **Print**.
 - 3 Press the **OK** key.
 - 4 Navigate to **Printout** and set it to **Short** or **Long** as needed.
 - 5 Press the **OK** key.
- ⇒ The result is printed.

Print all results or a subset of results

- A printer is connected.
 - The result list is displayed.
- 1 Press the **Report** key.
 - 2 Navigate to **Option** and select **Print**.
 - 3 Press the **OK** key.
 - 4 Navigate to **Printout** and set it to **Short** or **Long** as needed.
 - 5 Press the **OK** key.
 - 6 To print all results, deactivate the filter.
 - 7 To print a subset of results, configure the filter.
 - 8 Press the **Start** key.
- ⇒ The results are printed.

See also

- 📖 Configure the filter } Page 48
- 📖 Connect a printer } Page 15

5.10.3.3 Configure the filter

If you activate the filter, you can print or export a subset of the results. The following filters are available.

- **Off**: Filter is deactivated and all results are printed or exported.
- **Today**: Only the results from current day are printed or exported.
- **Range**: Only the results within the set date range are printed or exported.

Procedure

- 1 Press the **Menu** key.
- 2 Navigate to **Results** > **Report** > **Filter**.
- 3 Select the desired **Filter** type.
- 4 Press the **OK** key.
- 5 If you selected **Range**, define the values for **Start date** and **End date**.

See also

- 📖 Export results to EasyDirect Density & Refractometry } Page 47
- 📖 Print results } Page 47

6 Maintenance

In this chapter you find descriptions of the maintenance tasks you should perform on your density meter. Any other maintenance tasks need to be performed by a service technician that has been qualified by EEPS.

If you experience problems with your density meter, contact your authorized EEPS dealer or service representative.

EEPS recommends that a preventive maintenance and calibration certification is done at least once a year through your authorized EEPS dealer or service representative.

[u www.mt.com/contact](http://www.mt.com/contact)

6.1 Maintenance schedule

If the standard operating procedures of your company require other maintenance intervals, use the intervals listed in the standard operating procedures.

| Frequency | Task | See |
|-----------|--|--|
| Daily | Clean the measuring cell at the end of the work day. | [Clean the measuring cell } Page 50] |
| | Perform a test with deionized water. | [Check the measurement accuracy } Page 51] |

See also

 Activate and deactivate a cleaning reminder } Page 20

6.2 Clean the density meter



NOTICE

Danger of damage to the density meter due to inappropriate cleaning methods!

Inappropriate cleaning agents can damage the housing or other parts of the density meter. If liquids enter the housing they can damage the density meter.

- 1 Make sure the cleaning agent is compatible with the material of the part you want to clean.
- 2 Make sure that no liquid enters the interior of the density meter.

If you have questions about the compatibility of cleaning agents, contact your authorized EEPS dealer or service representative.

[u www.mt.com/contact](http://www.mt.com/contact)

6.2.1 Clean the housing

EEPS recommends the following cleaning agents:

- Water
- Water with a mild detergent

Procedure

- The density meter is shut down.
- Wipe the housing with a cloth moistened with the cleaning agent.

6.2.2 Clean the measuring cell

Because the measuring cell always contains residue from the last sample, there is a risk that the measuring cell can be damaged by the sample. To prevent such damages, EEPS recommends that you clean the measuring cell at the end of each sample series.

To clean the measuring cell, you need to rinse the measuring cell with a cleaning solution. The cleaning solution must have the following properties.

- Does not chemically interact with the material of the measuring cell.
- Dissolves the sample that was just measured.
- Evaporates without leaving incrustations.

EEPS recommends the following cleaning agents:

| Sample | Cleaning solution |
|---|--|
| Water Water based | Deionized water |
| Acids, concentrated | Water (flush the measuring cell with plenty of water to remove the heat from the reaction of water and acid) |
| Alkaline, concentrated | 0.3...0.5 % deconex solution |
| Samples with fats or oily components | 0.3...0.5 % deconex solution |
| Petrochemical samples Edible oils and fats | Toluene, xylene or petrol ether mixtures |

See also

📖 Activate and deactivate a cleaning reminder } Page 20

6.2.2.1 Clean using the sample pump

- The density meter is set up to work with the sample pump.
 - The cleaning solution is defined and available.
 - The piston is in the lowermost position.
- 1 Immerse the filling tube in the cleaning solution (1).
 - 2 Move the navigation joystick upwards and let go.
 - ⇒ The sample pump starts and stops when the piston is in the uppermost position.
 - 3 Lift the filling tube out of the cleaning solution and hold it over the waste beaker (2).
 - 4 Move the navigation joystick downwards and let go.
 - ⇒ The sample pump starts and stops when the piston is in the lowermost position.
 - 5 Clean the end of the filling tube with a clean tissue.
 - 6 Repeat the steps until all residue from the sample is removed.
 - 7 Move the navigation joystick upwards and let go.
 - ⇒ The sample pump fills the measuring cell with air.
 - 8 Move the navigation joystick downwards and let go.
 - ⇒ Most of the cleaning solution is removed from the measuring cell.
 - 9 Clean the end of the filling tube with a clean tissue.

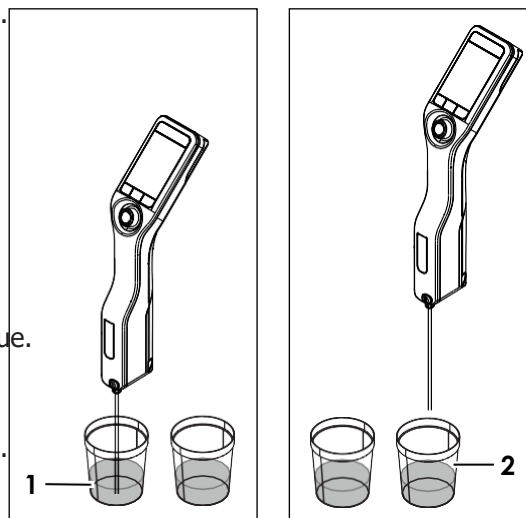

6.2.2.2 Clean using a syringe

- The density meter is set up to work with a syringe.
 - The cleaning solution is defined and available.
 - The measuring cell is drained.
- 1 Fill a syringe with the cleaning solution.
 - 2 Insert the syringe into the connector for the syringe.

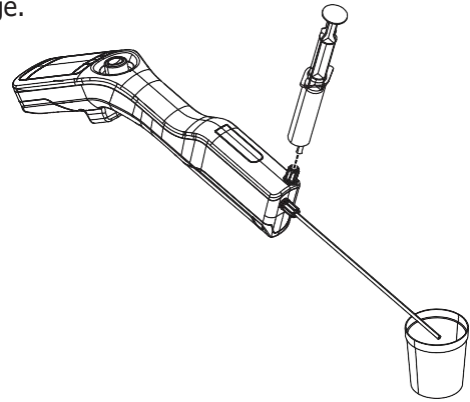

- 3 Hold the filling tube over the waste beaker (1).
- 4 Press the plunger continuously into the syringe until the syringe is empty.

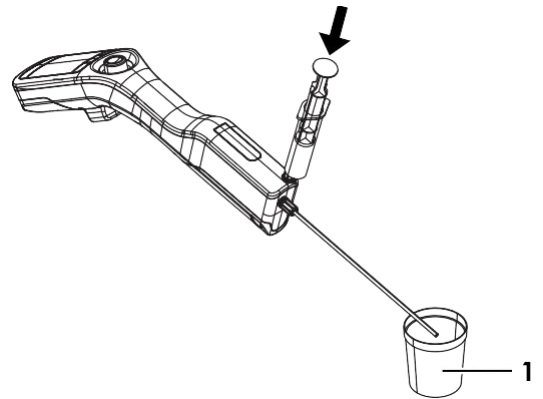

- 5 Pull the plunger continuously out of the syringe.
⇒ The cleaning solution is pulled back into the syringe and the measuring cell fills with air.
- 6 Remove the syringe and empty it into a suitable waste beaker.
- 7 Repeat the steps until all residue from the sample is removed.

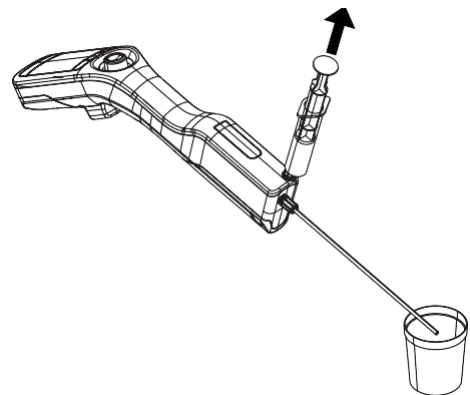

6.3 Check the measurement accuracy

To check the measurement accuracy of the density meter, you need to configure and perform a test. You can find more information about the configuration of a test in the chapter [Configure density determinations } Page 21].

6.3.1 Example: Test with water

The following chapters show you how to configure and perform a guided test with deionized water at room temperature (23 °C or 73.4°C).

6.3.1.1 Configure the test

- The density unit is set to [g/cm³].
 - **Confirmation of results** in **Settings** is activated.
- 1 Press the **Menu** key.
 - 2 Navigate to **Test**.
 - ⇒ The **Test** window opens.
 - 3 Change the parameter settings to the values shown in the following table.

| Parameter | Setting | Explanation |
|--------------------------|--------------------------|--|
| Workflow | Guided | The density meter prompts users to fill and drain the measuring cell. |
| Standard type | Water | The density meter uses predefined values for the water measurement. |
| Standard ID entry | Variable | The density meter prompts users to enter the identification before the density is measured. |
| Fill cycle | 3 | The density meter prompts users to fill and drain the measuring cell twice and then fill the measuring cell for the measurement. |
| Fill speed | High | The pump fills the measuring cell with 80 % of the maximum pump speed. |
| Tolerance d | 0.0002 g/cm ³ | The result is marked as passed if it falls within the following range. d nominal ± Tolerance d |
| Clean | Drain | Users are prompted to drain the measuring cell. |
| Printout | None | The result is not printed. |

See also

- 📖 Activate and deactivate the confirmation of results } Page 24
- 📖 Change the density unit } Page 18

6.3.1.2 Perform the test

Start the test

- The density meter is set up to work with the sample pump.
 - The measuring cell has been cleaned.
 - The piston is in the lowermost position.
- 1 Press the **Menu** key.
 - 2 Navigate to **Test**.
 - ⇒ The **Test** window opens.
 - 3 Press the **Start** key.
 - ⇒ The home screen opens.
 - 4 Press the **Start** key.
 - ⇒ The **Standard ID** window opens.
 - 5 Enter the identification.
 - 6 Press the **OK** key.

Rinse the measuring cell

- 1 Immerse the filling tube in the water.
- 2 Press the **OK** key.
 - ⇒ The sample pump starts and stops when the piston is in the uppermost position.

- 3 Hold the filling tube over the waste beaker.
- 4 Press the **OK** key.
 - ⇒ The sample pump starts and stops when the piston is in the lowermost position.
- 5 Clean the end of the filling tube with a clean tissue.
- 6 Repeat the steps once.

Fill the measuring cell and measure the density

- 1 Immerse the filling tube in the water.
- 2 Press the **OK** key.
 - ⇒ The sample pump starts and stops when the piston is in the uppermost position.
- 3 Make sure there are no bubbles in the measuring cell.
 - ⇒ The measurement starts.
 - ⇒ When the background of the measuring ribbon changes color, the measurement is finished.
 - ⇒ The measured value is saved in the results.
- 4 Press the **OK** key.

Drain the measuring cell

- 1 Hold the filling tube over the waste beaker.
- 2 Press the **OK** key.
 - ⇒ The sample pump starts and stops when the piston is in the lowermost position.
- 3 Clean the end of the filling tube with a clean tissue.

6.3.2 Measures if a test fails

- 1 Check if the correct standard has been used, and if needed repeat the test with the correct standard.
- 2 If the test continues to fail, clean the measuring cell with a cleaning solution that dissolves your samples and dissolves in the standard.
- 3 Repeat the test.
- 4 If the test continues to fail, repeat the test twice and compare all three results.
- 5 If the results are not the same, clean the measuring cell and perform tests until the test passes or the results of three consecutive tests are the same.
- 6 If the test continues to fail and the results of three consecutive tests are the same, restore the factory adjustment data and repeat the test.
- 7 If the test continues to fail, perform an adjustment.

See also

- 📖 Clean the measuring cell } Page 50
- 📖 Restore the factory adjustment data } Page 58
- 📖 Adjust the measurement accuracy } Page 58

6.4 Replace the battery

The density meter works with a rechargeable 2400 mAh Li-Ion battery that you can order from EEPS.

- 1 Press on the lower part (1) of the battery cover and push the battery cover up.
- 2 Pull the upper part of the battery out of the battery compartment and lift the battery out.

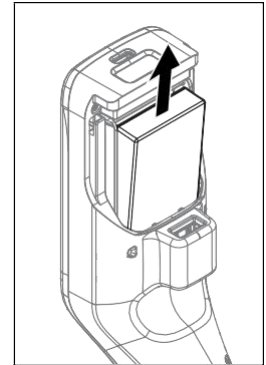
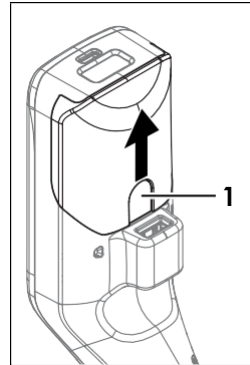

- 3 Insert the lower part of the battery at an angle into the battery compartment.
- 4 Push the upper part of the battery into the battery compartment.
- 5 Slide the battery cover from above onto the density meter.

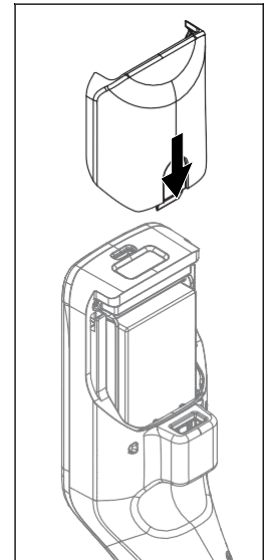
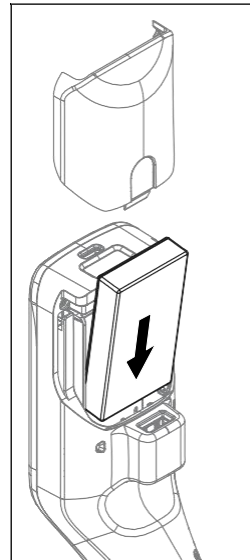

See also

- 📖 Accessories } Page 65
- 📖 Technical data } Page 62

6.5 Replace the filling tube

- 1 Unscrew the filling tube by hand and remove it.
- 2 Install the new filling tube.

See also

- 📖 Accessories } Page 65
- 📖 Install the filling tube } Page 13

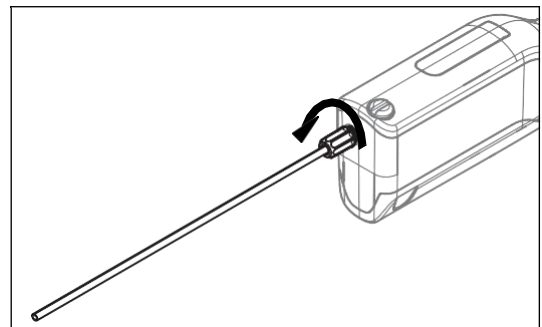

6.6 Replace the sample pump

Remove the sample pump

- The measuring cell is drained.
- 1 Move the navigation joystick upwards and let go.
 - ⇒ The sample pump starts and stops when the piston is in the uppermost position.
 - 2 Shut down the density meter.

- 3 Press on the grip recesses (4) of the cover and lift the lower part of the cover out of the housing.
- 4 Pull the top of the cover out of the housing.
- 5 Lift the piston (1) out of the guide system.
- 6 Pull the cylinder (2) up and out of its guide system (3).

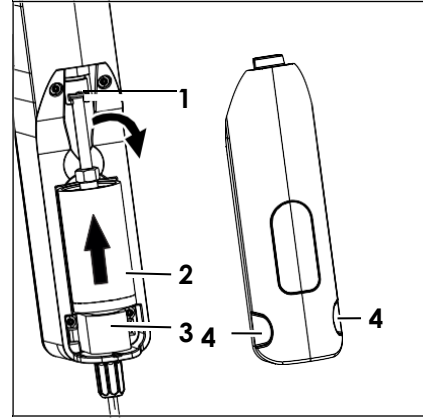

Install the sample pump

- 1 Insert the cylinder (3) of the sample pump in its guide system (4).
- 2 Insert the piston (1) in its guide system (2).
- 3 To check if the sample pump works, move the navigation joystick downwards and let go.
⇒ The sample pump starts and stops when the piston is in the lowermost position.
- 4 Reinstall the cover of the sample pump.

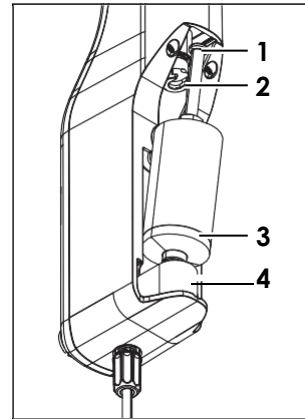

See also

📖 Accessories } Page 65

6.7 Update the firmware

It is possible to update the firmware of your density meter. To update the firmware of the density meter, contact an authorized EEPS dealer or service representative.

u www.mt.com/contact

6.8 Prepare the density meter for storage

The density meter can be stored at temperatures of -20...+50 °C (-4...+122 °F). But the lifespan of the battery is reduced when it is stored at high temperatures.

- 1 Clean the measuring cell.
- 2 Shut down the density meter.
- 3 Clean the housing.
- 4 Store the density meter in a dry and clean place.

See also

📖 Clean the density meter } Page 49

📖 Technical data } Page 62

6.9 Ship the density meter

If you have questions about transporting your density meter, contact your authorized EEPS dealer or service representative.

u www.mt.com/contact

- 1 Shut down the density meter.

- 2 Clean the density meter.
- 3 Ship the density meter using the original packaging.

6.10 Dispose of the density meter

In conformance with the European Directive 2012/19/EU on Waste Electrical and Electronic Equipment (WEEE) this device may not be disposed of in domestic waste. This also applies to countries outside the EU, per their specific requirements.

Please dispose of this product in accordance with local regulations at the collecting point specified for electrical and electronic equipment. If you have any questions, please contact the responsible authority or the distributor from which you purchased this device. Should this device be passed on to other parties (for private or professional use), the content of this regulation must also be related.

Thank you for your contribution to environmental protection.



7 Troubleshooting

7.1 List of errors and problems

| Problem | Possible cause | Measure |
|---|---|--|
| The sample pump does not aspirate any liquid. | The locking screw is not installed. | – Install the locking screw. |
| | The locking screw is not tight. | – Tighten the locking screw. |
| Test of measurement accuracy fails. | The measuring cell is not clean. | See [Measures if a test fails } Page 53]. |
| | Mismatch between measured and configured standard | See [Measures if a test fails } Page 53]. |
| | The tolerance range is too small. | See [Configure the tolerance for a test } Page 33]. |
| | The density meter is not adjusted correctly. | See [Measures if a test fails } Page 53]. |
| The message Drain cell over waste beaker. is displayed when you try to start a method. | The piston is not in the lowermost position. | <ol style="list-style-type: none"> 1 Hold the filling tube over the waste beaker. 2 Move the navigation joystick downwards and let go. <ul style="list-style-type: none"> ⇒ The sample pump starts and stops when the piston is in the lowermost position. 3 Clean the end of the filling tube with a clean tissue. |
| There are bubbles in the measuring cell. | Fill speed is too high. | <ol style="list-style-type: none"> 1 If you use the sample pump, lower the setting for fill speed. See [Define the pump speed } Page 23]. 2 If you use a syringe, press the syringe plunger more slowly into the syringe. |
| | | The liquid contains dissolved gases. |
| | Connector for syringe or the filling tube is not tight. | <ol style="list-style-type: none"> 1 Tighten the connector of the filling tube. 2 Tighten the locking screw or the connector for the syringe. |

| Problem | Possible cause | Measure |
|--|--|--|
| The message Pump position unknown. is displayed. | The saved pump position was lost because the battery was removed too long. | <p>The density meter is set up to work with a syringe.</p> <ul style="list-style-type: none"> - You can ignore the message and continue to work with the density meter. <p>The density meter is set up to work with the sample pump.</p> <ol style="list-style-type: none"> 1 Hold the filling tube over the waste beaker. 2 Move the navigation joystick downwards and let go. <ul style="list-style-type: none"> ⇒ The sample pump starts and stops when the piston is in the lowermost position. 3 Clean the end of the filling tube with a clean tissue. |
| "--" is displayed, instead of a value for Alpha*1000. | The calculated value is out of range. | <ul style="list-style-type: none"> - Check and correct the density values and the values for the compensation temperatures you entered. |
| "--" is displayed, instead of a measured value or a result. | The measured value or the result is out of range. | <ol style="list-style-type: none"> 1 Check that the unit defined in the method matches the sample you want to measure. 2 If you use a user-defined conversion, check that all the settings are correct. |

7.2 Restore the factory adjustment data

If you restore the factory adjustment data, the current adjustment data is overwritten with the adjustment data that were determined when the density meter was adjusted during production.

- 1 Press the **Menu** key.
- 2 Navigate to **Maintenance & Service > Reset to factory adjust..**
 - ⇒ The message **Do you want to reset to factory adjustment?** opens.
- 3 To overwrite the current adjustment data with the factory adjustment data, press **Yes.**
 - ⇒ The factory adjustment data are restored.

7.3 Adjust the measurement accuracy



NOTICE

Danger of incorrect results due to incorrect adjustment!

Adjustments that are not performed properly can lead to inaccurate results.

- 1 Make sure the results of the test are repeatable.
- 2 Only perform an adjustment if you are qualified to do it.

The following chapters show you, how to configure and perform an exemplary adjustment with water. You can find more information about the configuration of an adjustment in the chapter [Configure density determinations } Page 21].

See also

📖 Measures if a test fails } Page 53

7.3.1 Example: Adjustment with water

The following chapters show you how to configure and perform a guided adjustment with deionized water at room temperature (23 °C or 73.4 °C).

7.3.1.1 Configure the adjustment

- **Confirmation of results** in **Settings** is activated.

- 1 Press the **Menu** key.
- 2 Navigate to **Adjustment**.
 - ⇒ The **Adjustment** window opens.
- 3 Change the parameter settings to the values shown in the following table.

| Parameter | Setting | Explanation |
|--------------------------|-----------------|--|
| Workflow | Guided | The density meter prompts users to fill and drain the measuring cell. |
| Standard type | Water | The density meter uses predefined values for the water measurement. |
| Standard ID entry | Variable | The density meter prompts users to enter the identification before the density is measured. |
| Fill cycle | 3 | The density meter prompts users to fill and drain the measuring cell twice and then fill the measuring cell for the measurement. |
| Fill speed | High | The pump fills the measuring cell with 80 % of the maximum pump speed. |
| Clean | Drain | Users are prompted to drain the measuring cell. |
| Printout | None | The result is not printed. |

7.3.1.2 Perform the adjustment

Start the adjustment

- The density meter is set up to work with the sample pump.
 - The measuring cell has been cleaned.
 - The piston is in the lowermost position.
- 1 Press the **Menu** key.
 - 2 Navigate to **Adjustment**.
 - ⇒ The **Adjustment** window opens.
 - 3 Press the **Start** key.
 - ⇒ The home screen opens.
 - 4 Press the **Start** key.
 - ⇒ The **Standard ID** window opens.
 - 5 Enter the identification.
 - 6 Press the **OK** key.

Rinse the measuring cell

- 1 Immerse the filling tube in the water(1).
- 2 Press the **OK** key.
 - ⇒ The sample pump starts and stops when the piston is in the uppermost position.
- 3 Hold the filling tube over the waste beaker (2).
- 4 Press the **OK** key.
 - ⇒ The sample pump starts and stops when the piston is in the lowermost position.
- 5 Clean the end of the filling tube with a clean tissue.
- 6 Repeat the steps once.

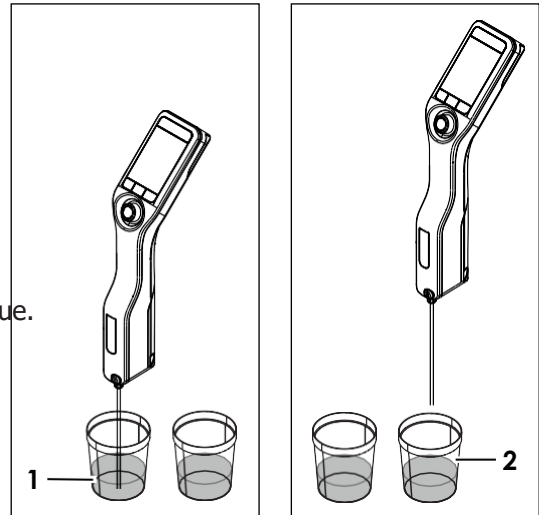

Fill the measuring cell and measure the density

- 1 Immerse the filling tube in the water(1).
- 2 Press the **OK** key.
 - ⇒ The sample pump starts and stops when the piston is in the uppermost position.
- 3 Make sure there are no bubbles in the measuring cell.
 - ⇒ The measurement starts.
 - ⇒ When the background of the measuring ribbon changes color, the measurement is finished.
 - ⇒ The measured value is saved in the results.
- 4 Accept or reject the adjustment.

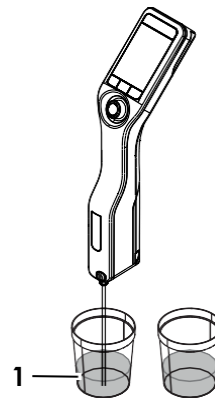

Drain the measuring cell

- 1 Hold the filling tube over the waste beaker (1).
- 2 Press the **OK** key.
 - ⇒ The sample pump starts and stops when the piston is in the lowermost position.
- 3 Clean the end of the filling tube with a clean tissue.

See also

- 📖 Activate and deactivate the confirmation of results } Page 24

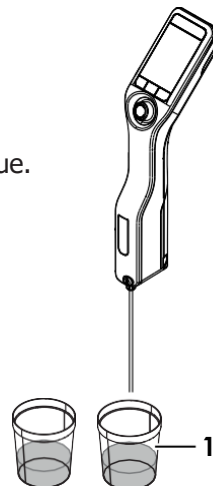

7.4 Restore the factory settings



NOTICE

Loss of data

With a factory reset all user-specific settings are set to the default values and all saved data (e.g. sample IDs, results, Method IDs and adjustment data) are deleted.

- Document the data you need before you restore the factory settings.

- 1 Press the **Menu** key.
- 2 Navigate to **Maintenance & Service > Reset to factory settings**.
 - ⇒ The dialog **Do you want to reset all values to factory settings?** opens.
- 3 To reset the density meter to factory settings, press the **Yes** key.
 - ⇒ The density meter restarts.

7.5 View the firmware version and other system information

- The home screen is open.
- 1 Press the **Menu** key.
 - 2 Navigate to **Information**.
 - ⇒ The firmware version and other system information are displayed.

| | |
|-----------------|---|
| Instrument type | Shows if the density meter is a SG-Pro or DensitoPro. |
|-----------------|---|

| | |
|----------------|--|
| SNR instrument | Shows the serial number of the instrument. |
|----------------|--|

| | |
|------------------|--|
| Firmware version | Shows the firmware version of the density meter. |
|------------------|--|

| | |
|----------|--|
| Licenses | Opens a window with information on the End User License Agreement, third party licenses and open source attribution files. |
|----------|--|

8 Technical data

8.1 Density meter

| Characteristic | Value | |
|---|---|--|
| Power rating instrument | Input values | 5 V DC, 1.0 A |
| | Connector type | USB C |
| Power rating AC adapter | Input values | 100...240 V AC, 0.3 A |
| | Input frequency | 50 - 60 Hz |
| | Output values | 5 V DC, 1.0 A |
| Battery | Type | Rechargeable lithium-ion battery |
| | Capacity | 2400 mAh |
| | Temperature range for charging | 0...40 °C |
| Dimensions | Width | 56 mm |
| | Length | 288 mm |
| | Depth | 80 mm |
| | Weight | 355 g |
| Screen | Technology | Color screen |
| | Size | 2.4" |
| | Resolution | 240 x 320 pixels |
| USB type A | Data rate | USB 2.0, host fullspeed |
| | Output voltage | 5 V DC \pm 5 % |
| | Max. output current | 250 mA |
| USB type C | Data rate | USB 2.0, device fullspeed |
| | Input voltage | 5 V DC \pm 10 % |
| | Max. input current | 400 mA, max. 1 A with AC adapter |
| RFID reader (DensitoPro only) | Compatibility | METTLER TOLEDO Smart Tags |
| Barcode reader (DensitoPro only) | Format | Linear barcodes |
| Materials | Housing | PBT (polybutylene terephthalate) |
| | Measuring cell | Borosilicate glass |
| | Parts in contact when working with sample pump | PTFE (polytetrafluorethylene) PVDF (polyvinylidene difluoride) EPDM (ethylene propylene diene monomer (M-class) rubber) FFKM (perfluoro-elastomers) Borosilicate glass |
| | Filling tube | PTFE (polytetrafluorethylene) |
| | Connector for filling tube or syringe | PP (polypropylene) |
| | | |
| Ambient conditions | | |
| Characteristic | Value | |
| Ambient temperature (SG-Pro) | -10...+50 °C | |
| Ambient temperature (DensitoPro) | 0...+50 °C | |
| Relative humidity | Max. 80 % (non-condensing) at 31 °C, linear fall to 50 % at 40 °C | |

| Characteristic | Value |
|----------------------|------------------------------|
| Altitude | Up to 2000 m above sea level |
| Pressure | Atmospheric pressure |
| Use | In interior spaces |
| Overvoltage category | II |
| Pollution degree | 2 |
| IP code | IP5X |

Storage temperatures

| Characteristic | Value | |
|-------------------|----------------------------|-----------------|
| Instrument | -20 °C...+50 °C | |
| Battery | Storage for up to 1 month | -20 °C...+60 °C |
| | Storage for up to 3 months | -20 °C...+45 °C |
| | Storage for up to 1 year | -20 °C...+30 °C |

Directives, standards and REACH regulation

Directives and standards complied with are listed on the declaration of conformity.

SVHC candidate substances according to REACH (Article 33)

| Material | CAS No. |
|-------------------------------|------------|
| 1,3-Propanesultone | 1120-71-4 |
| PZT (Lead Zirconate Titanate) | 12626-81-2 |

8.2 Measurement

| Characteristic | Value | |
|---------------------------------|---|---------------------------------|
| Density | Measuring range | 0.000...3.000 g/cm ³ |
| | Accuracy ¹⁾ | ± 0.001 g/cm ³ |
| | Repeatability | ± 0.0005 g/cm ³ |
| | Resolution | 0.0001 g/cm ³ |
| Temperature | Temperature range for sample | 0...50 °C |
| | Resolution | 0.1 °C |
| | Accuracy | ±0.2 °C |
| Viscosity | Using sample pump | 0...100 mPa*s |
| | Using syringe | 0...1000 mPa*s |
| Volumes | Sample pump | 5 mL |
| | Min. sample volume | 2 mL |
| Temperature compensation | Automatic or by using a user-defined temperature correction coefficient | |
| Application | Max. number of methods | 30 |
| | Stored results | 1100 |

¹⁾ For viscosity range of 0...200 mPa*s

Measurement scales

| Characteristic | Value | |
|--------------------------|----------|------------------|
| Ethanol (d) % w/w | Range | 0.0. 100.0 % w/w |
| | Accuracy | ±1.0 % w/w |
| Ethanol (d) % v/v | Range | 0.0..... % v/v |
| | Accuracy | ±1.0 % v/v |

| Characteristic | | Value |
|--------------------------------------|---------------------|------------------|
| Proof (IP) | Range | 0.0. 175.0 Proof |
| | Accuracy | ±1.75 Proof |
| Proof (US) | Range | 0.0. 200.0 Proof |
| | Accuracy | ±2.0 Proof |
| Light Baumé | Range | 10...100 °Bé |
| | Accuracy | ±0.4 °Bé |
| Heavy Baumé | Range | 0...72 °Bé |
| | Accuracy | ±0.1 °Bé |
| H ₂ SO ₄ % w/w | Temperature range | 10...50 °C |
| | Concentration range | 0.0. 100.0 % w/w |
| | Accuracy | ±1.0 % w/w |
| H ₂ SO ₄ % v/v | Temperature range | 10...50 °C |
| | Concentration range | 0.0.% v/v |
| | Accuracy | ±1.0 % v/v |
| Brix (d) % w/w | Range | 0.0. 85.0 % w/w |
| | Accuracy | ±0.3 % w/w |
| Plato | Range | 0.0. 85.0 °P |
| | Accuracy | ±0.3 °P |

International standards and norms

International standards and norms complied with are listed on the internet.

9 Accessories

The following accessories and parts are available for the density meters SG-Pro and DensitoPro. All parts are specified with their order number and quantity in cases where more than one part is included. When ordering, some parts are only available in a minimum order quantity. In such cases, the corresponding minimum order quantity is quoted. Certain parts are only available in specific countries. If you have any questions, contact your authorized EEPS dealer.

9.1 Sampling

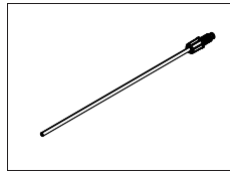

Filling Tube
190 mm

30330847

- Tube
- Connector syringe/filling tube
- Washer

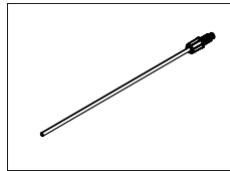

Filling tube
600 mm

30330848

- Tube
- Connector syringe/filling tube
- Washer

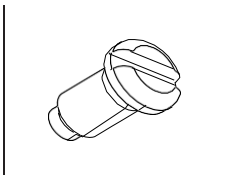

Locking Screw, SG-Pro

30330852

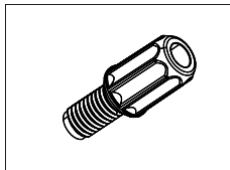

Connector syringe/filling tube

30330853

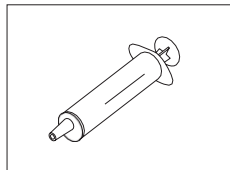

Disposable syringe (100 pcs)
10 mL

51338100

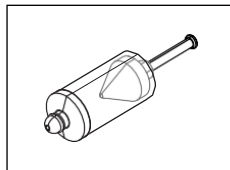

Sample pump

30330849

- Piston
- Glass cylinder

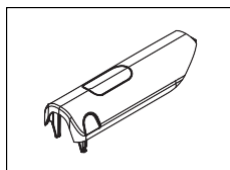

Sample pump cover

30330851

9.2 Printers

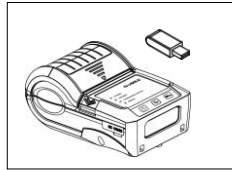

Bluetooth Printer Godex MX20 with Dongle

30330864

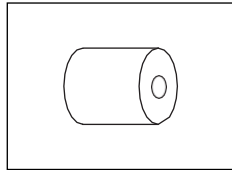

Bluetooth Printer Paper (5 rolls)

30330865

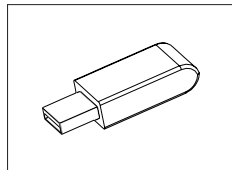

Bluetooth Dongle Godex MX20

30330863

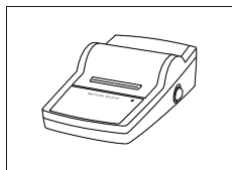

Lab equip access. data writer USB-P25/01

11124301

9.3 Miscellaneous accessories

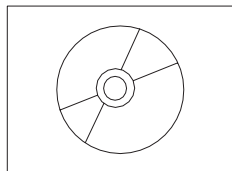

EasyDirect Density & Refractometry PC Software

30451628

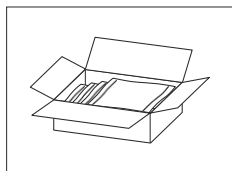

Density standards (10 pcs)
6 mL

51325005

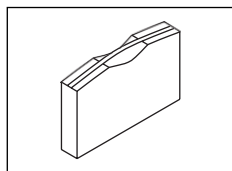

Carrying Case

30330861

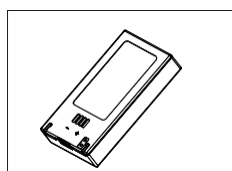

Battery Li-Ion 2400mAh

30330855

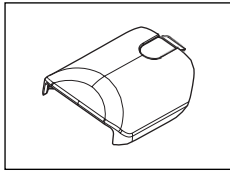

Battery cover

30330854

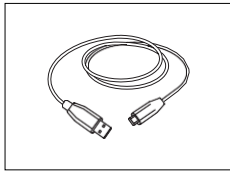

USB-C Cable

30449253

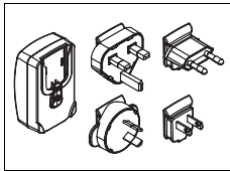

Power Supply and Worldwide Adapters

30449255

Accessories for DensitoPro

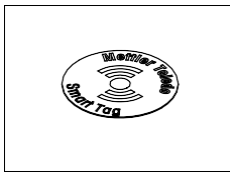

Tag SmartSample(10 pcs)

30449268

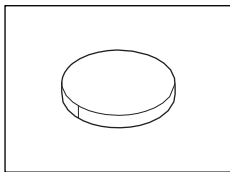

Tag SmartSample Film for Tanks(10 pcs)

30449269

10 Appendix

10.1 Density of pure water (0...40 °C)

| Temperature [°C] | Density [g/cm ³] | Temperature [°C] | Density [g/cm ³] |
|------------------|------------------------------|------------------|------------------------------|
| 0 | 0.99984 | | |
| 1 | 0.99990 | 21 | 0.99799 |
| 2 | 0.99994 | 22 | 0.99777 |
| 3 | 0.99996 | 23 | 0.99754 |
| 4 | 0.99997 | 24 | 0.99730 |
| 5 | 0.99996 | 25 | 0.99705 |
| 6 | 0.99994 | 26 | 0.99679 |
| 7 | 0.99990 | 27 | 0.99652 |
| 8 | 0.99985 | 28 | 0.99624 |
| 9 | 0.99978 | 29 | 0.99595 |
| 10 | 0.99970 | 30 | 0.99565 |
| 11 | 0.99961 | 31 | 0.99534 |
| 12 | 0.99950 | 32 | 0.99503 |
| 13 | 0.99938 | 33 | 0.99471 |
| 14 | 0.99925 | 34 | 0.99438 |
| 15 | 0.99910 | 35 | 0.99404 |
| 16 | 0.99894 | 36 | 0.99369 |
| 17 | 0.99878 | 37 | 0.99333 |
| 18 | 0.99860 | 38 | 0.99297 |
| 19 | 0.99841 | 39 | 0.99260 |
| 20 | 0.99821 | 40 | 0.99222 |

[Chemical Handbook Fundamental Version, Rev. 3, Table 5.2 (1984)]

10.2 Temperature-compensation coefficients α

| Substance | Temperature range [°C] | $\alpha \cdot 10^3 / ^\circ\text{C}$ |
|----------------------|------------------------|--------------------------------------|
| Water | 15...30 | 0.23 |
| Ethanol | 0...30 | 1.09 |
| m-xylene | 0...30 | 0.99 |
| p-xylene | 15...30 | 1.02 |
| Glycerine | 15...30 | 0.49 |
| Chloroform | 0...30 | 1.26 |
| Carbon tetrachloride | 0...30 | 1.22 |
| Toluene | 0...30 | 1.07 |
| Benzene | 6...30 | 1.21 |
| Methanol | 6...30 | 1.18 |
| Acetone | 0...30 | 1.42 |
| Bromobenzene | 0...30 | 0.91 |
| Cyclohexane | 0...30 | 1.20 |
| Isopropanol | 0...30 | 1.06 |
| n-nonane | 0...30 | 1.08 |

Index

A

| | |
|------------------------------|--------------------|
| AC adapter | |
| Assemble | 12 |
| Change prongs | 12 |
| Connect | 12 |
| Accessories | 65 |
| Activate | |
| Audio signal | 20 |
| Auto rotation | 20 |
| Barcode reader | 13 |
| Cleaning reminder | 20 |
| Confirmation of results | 24 |
| Password protection | 19 |
| RFID reader | 13 |
| Sample pump mode | 13 |
| Syringe mode | 14 |
| Adjustment | |
| Change | 22 |
| Configure | 23, 29, 30, 31, 32 |
| Configure example | 59 |
| Density unit | 18 |
| Perform | 58 |
| Perform example | 59 |
| Alcohol concentration | 24 |
| Masspercent | 26 |
| Proof (IP) | 26 |
| Proof (US) | 26 |
| Volume percent | 26 |
| Alpha | |
| Configure | 29 |
| Table | 68 |
| Ambient conditions | 62 |
| American Petroleum Institute | 24 |
| API | 24 |
| API degree | 26 |
| Density | 26 |
| Specific gravity | 26 |
| Assemble | |
| ACadapter | 12 |
| Filling tube | 13 |
| Audio signal | |
| Activate | 20 |
| Deactivate | 20 |
| Auto rotation | |

| | |
|------------|----|
| Activate | 20 |
| Deactivate | 20 |

B

| | |
|---------------------|--------|
| Barcode reader | |
| Activate | 13 |
| Deactivate | 13 |
| Read | 45 |
| Battery | |
| Install | 53 |
| Remove | 53 |
| Replace | 53 |
| Storage temperature | 63 |
| Technical data | 62 |
| Baumé | 24, 26 |
| Beep | |
| Activate | 20 |
| Deactivate | 20 |
| Bluetooth printer | |
| Connect | 15, 16 |
| Brightness | |
| Change | 18 |
| Dimming | 18 |
| Brix | 27 |

C

| | |
|-------------------|----|
| Celsius | 18 |
| Change | |
| Adjustment | 22 |
| Date | 17 |
| Date format | 17 |
| Density unit | 18 |
| Keyboard layout | 20 |
| Language | 20 |
| Method | 22 |
| Password | 20 |
| Prongs AC adapter | 12 |
| Screen brightness | 18 |
| Temperature unit | 18 |
| Test | 22 |
| Time | 17 |
| Time format | 17 |
| Charge | |
| Density meter | 12 |
| Clean | |
| Housing | 49 |

| | |
|------------------------------------|----------------------------|
| Measuring cell | 50 |
| Cleaning reminder | |
| Activate | 20 |
| Deactivate | 20 |
| Concentration | |
| Alcohol | 24 |
| Sugar | 24 |
| Sulfuric acid | 24 |
| User-defined | 24, 27 |
| Configure | |
| Adjustment | 22, 23, 29, 30, 31, 32 |
| Alpha | 29 |
| Drain | 23 |
| Measurement reliability | 24 |
| Method | 22, 23, 24, 29, 30, 31, 32 |
| Result limits | 32 |
| Rinse | 23 |
| Standard | 32 |
| Test | 22, 23, 29, 30, 31, 32, 33 |
| Tolerance | 33 |
| User-guidance | 23 |
| Configure example | |
| Adjustment | 59 |
| Guided | 36, 39 |
| Sample pump | 36, 42 |
| Syringe | 39 |
| Test | 52 |
| Unguided | 42 |
| Confirm settings | 35 |
| Confirmation of results | |
| Activate | 24 |
| Deactivate | 24 |
| Connect | |
| AC adapter | 12 |
| Bluetooth printer | 15, 16 |
| EasyDirect Density & Refractometry | 17 |
| Godex MX20 | 15, 16 |
| Power supply | 12 |
| USB printer | 15, 16 |
| Connector for syringe | |
| Install | 15 |
| Material | 62 |
| Contact | 5 |
| Create | |
| Method | 21 |

| | |
|-------------------------|--------|
| D | |
| Date | |
| Change | 17 |
| Date format | |
| Change | 17 |
| Deactivate | |
| Audio signal | 20 |
| Auto rotation | 20 |
| Barcode reader | 13 |
| Cleaning reminder | 20 |
| Confirmation of results | 24 |
| Password protection | 19 |
| RFID reader | 13 |
| Sample pump | 14 |
| Sample pump mode | 14 |
| Syringe mode | 13 |
| Delete | |
| Method | 22 |
| Results | 46 |
| Density | 24, 25 |
| Temperature compensated | 25 |
| Density determination | |
| Typical phases | 36 |
| Density meter | |
| Charge | 12 |
| Functions | 8 |
| Overview | 8 |
| Ship | 55 |
| Shut down | 34 |
| Start up | 34 |
| Store | 55 |
| Unpack | 11 |
| Density of pure water | |
| Table | 68 |
| Density unit | |
| Adjustment | 18 |
| Change | 18 |
| Test | 18 |
| Dimming | |
| Automatic | 18 |
| Disposal | 56 |
| Drain | |
| Background | 36 |
| Configure | 23 |
| Guided | 39, 42 |
| Sample pump | 44 |

| | |
|------------------------------------|--------|
| Syringe | 42 |
| Unguided | 44 |
| E | |
| <hr/> | |
| EasyDirect Density & Refractometry | |
| Connect | 17 |
| Export | 32 |
| End user license agreement | 5 |
| Energy saver | 18 |
| Enter | |
| Number | 35 |
| Special character | 35 |
| Symbol | 35 |
| Text | 35 |
| Errors | |
| List | 57 |
| Export | |
| Results | 32, 47 |
| F | |
| <hr/> | |
| Factory adjustment | |
| Restore | 58 |
| Factory settings | |
| Restore | 61 |
| Fahrenheit | 18 |
| Fill | |
| Background | 36 |
| Guided | 38, 41 |
| Sample pump | 44 |
| Syringe | 41 |
| Unguided | 44 |
| Fill speed | 23 |
| Filling tube | |
| Assemble | 13 |
| Install | 13 |
| Material | 62 |
| Remove | 54 |
| Replace | 54 |
| Firmware | |
| End user license agreement | 5 |
| Open source attribution files | 5 |
| Third party licenses | 5 |
| Update | 55 |
| Version | 5, 61 |
| G | |
| <hr/> | |
| Godex MX20 | |
| Connect | 15, 16 |

| | |
|---------------------------------------|----|
| H | |
| <hr/> | |
| Housing | |
| Clean | 49 |
| Material | 62 |
| I | |
| <hr/> | |
| Icons | 10 |
| Identification | |
| Sample | 30 |
| Standard | 30 |
| Install | |
| Battery | 53 |
| Connector for syringe | 15 |
| Filling tube | 13 |
| Sample pump | 55 |
| Syringe adapter | 15 |
| Intended use | 6 |
| K | |
| <hr/> | |
| Key functions ribbon | 10 |
| Keyboard | |
| Change layout | 20 |
| Overview | 35 |
| L | |
| <hr/> | |
| Language | |
| Change | 20 |
| M | |
| <hr/> | |
| Maintenance | |
| Schedule | 49 |
| Material | |
| Connector for filling tube or syringe | 62 |
| Filling tube | 62 |
| Housing | 62 |
| Measuring cell | 62 |
| Sample pump | 62 |
| Measurement accuracy | |
| Adjust | 58 |
| Check | 51 |
| Measurement reliability | |
| Configure | 24 |
| Measuring cell | 9 |
| Clean | 50 |
| Material | 62 |
| Measuring ribbon | 10 |
| Method | |
| Change | 22 |

| | | | |
|-------------------------------|------------------------|--------------------|----|
| Configure | 23, 24, 29, 30, 31, 32 | Sample pump | 54 |
| Create | 21 | Replace | |
| Delete | 22 | Battery | 53 |
| Method ribbon | 10 | Filling tube | 54 |
| N | | Sample pump | 54 |
| <hr/> | | | |
| Navigate | 35 | Reset | |
| Number | | Factory adjustment | 58 |
| Enter | 35 | Factory settings | 61 |
| O | | Restore | |
| <hr/> | | | |
| Open source attribution files | 5 | Factory settings | 61 |
| Overview | | Factory adjustment | 58 |
| Functions | 8 | Result limits | |
| Instrument | 8 | Configure | 32 |
| Keyboard | 35 | Results | |
| P | | Delete | 46 |
| <hr/> | | | |
| Parts | 65 | View | 46 |
| Password | | RFID reader | |
| Change | 20 | | |
| Password protection | 19 | | |
| Activate | 19 | | |
| Deactivate | 19 | | |
| Perform | | | |
| Adjustment | 58 | | |
| Test | 51 | | |
| Perform example | | | |
| Adjustment | 59 | | |
| Method | 38, 40, 43 | | |
| Test | 52 | | |
| Plato | 27 | | |
| Power supply | | | |
| Connect | 12 | | |
| Print | | | |
| Results | 31, 47 | | |
| Printer | | | |
| Connect | 15 | | |
| Test | 16 | | |
| Printout | 31 | | |
| R | | | |
| <hr/> | | | |
| Read | | | |
| Barcode reader | 45 | | |
| RFID reader | 45 | | |
| Remove | | | |
| Battery | 53 | | |
| Filling tube | 54 | | |
| Export | 32, 47 | | |
| Print | 31, 47 | | |

| | |
|-----------------|--------|
| Activate | 13 |
| Deactivate | 13 |
| Metal container | 44 |
| Read | 45 |
| Write | 45 |
| Rinse | |
| Background | 36 |
| Configure | 23 |
| Guided | 38, 40 |
| Sample pump | 43 |
| Syringe | 40 |
| Unguided | 43 |

S

| | |
|--------------------|----|
| Safety information | |
| Signal words | 6 |
| Warningsymbols | 6 |
| Sample | |
| Identification | 30 |
| Sample ID ribbon | 10 |
| Sample pump | |

| | |
|------------|----|
| Deactivate | 14 |
| Drain | 44 |
| Fill | 44 |
| Install | 55 |
| Material | 62 |
| Remove | 54 |
| Replace | 54 |

| | | | |
|-------------------------|--------|--------------------------------------|------------------------|
| Rinse | 43 | Status ribbon | 10 |
| Set up | 13 | Store | |
| Sample pump mode | | Battery | 63 |
| Activate | 13 | Density meter | 55 |
| Deactivate | 14 | Sucrose concentration | 24 |
| Sampling ribbon | 10 | Sugar concentration | 24 |
| Scope of delivery | 11 | Brix | 27 |
| Screen | | Plato | 27 |
| Auto rotation | 20 | Sulfuric acid concentration | 24 |
| Brightness | 18 | Masspercent | 27 |
| Dimming | 18 | Volumepercent | 27 |
| Serial number | 61 | Switch off | |
| Set up | | Densitymeter | 34 |
| Sample pump | 13 | Switch on | |
| Syringe | 14 | Densitymeter | 34 |
| Ship | | Symbol | 5, 10 |
| Density meter | 55 | Enter | 35 |
| Shortcut method list | 35 | Syringe | |
| Shut down | | Drain | 42 |
| Automatic | 18 | Fill | 41 |
| Density meter | 34 | Rinse | 40 |
| Signal words | 6 | Set up | 14 |
| Site requirements | 6, 62 | Syringe adapter | |
| Smart Tag | | Install | 15 |
| Metal container | 44 | Syringe mode | |
| Read | 45 | Activate | 14 |
| Write | 45 | Deactivate | 13 |
| Special character | | T | |
| Enter | 35 | Technical data | 62 |
| Specific gravity | 24, 25 | Temperature compensated | |
| Temperature compensated | 25 | Density | 25 |
| Standard | | Specific gravity | 25 |
| Configure | 32 | Temperature unit | |
| Identification | 30 | Change | 18 |
| Standard delivery | 11 | Temperature-compensation coefficient | 29 |
| Start adjustment | | Configure | 29 |
| Guided | 59 | Values | 68 |
| Start method | | Test | |
| Guided | 38, 40 | Change | 22 |
| Sample pump | 38 | Configure | 23, 29, 30, 31, 32, 33 |
| Syringe | 40 | Configure example | 52 |
| Unguided | 43 | Density unit | 18 |
| Start test | | Failed | 53 |
| Guided | 52 | Perform | 51 |
| Start up | | Perform example | 52 |
| Density meter | 34 | Printer | 16 |

| | |
|----------------------|--------|
| Start guided | 52 |
| Text | |
| Enter | 35 |
| Third party licenses | 5 |
| Time | |
| Change | 17 |
| Time format | |
| Change | 17 |
| Tolerance | |
| Configure | 33 |
| Troubleshooting | |
| List of errors | 57 |
| Turn off | |
| Density meter | 34 |
| Turn on | |
| Density meter | 34 |
| U | |
| <hr/> | |
| Unit | |
| Density | 18 |
| Temperature | 18 |
| Unpack | 11 |
| Update | |
| Firmware | 55 |
| USB printer | |
| Connect | 15, 16 |
| User guidance | |
| Configure | 23 |
| V | |
| <hr/> | |
| View | |
| Firmware version | 61 |
| Results | 46 |
| W | |
| <hr/> | |
| Warning symbols | 6 |
| Write | |
| RFID reader | 45 |