

SKF Microlog Inspector / SKF MARLIN Systems Accessories Catalog



Foreword

SKF Microlog Inspector Systems

Around the world, successful condition monitoring programs begin with SKF

Industrial operations everywhere acknowledge that condition monitoring is critical to the success of their maintenance strategy. With the right tools – and the right machine data – they can optimize maintenance for both productivity and long-term protection of their assets. As a pioneer in the condition monitoring industry, SKF has led the way with innovations that have made it easier to collect, analyze, use and share inspection and machine data.

Technology designed to automate inspections

The SKF Microlog Inspector is a powerful system developed by SKF for recording inspection data. This system is used by operators as a replacement for verbal or paper inspection trails to document their observations with accurate, consistent and actionable information. SKF Microlog Inspector is ideally suited for operational efficiency, process and quality inspections, environmental, safety and regulatory compliance inspections, predictive and preventive maintenance inspections, as well as asset basic care.

This catalog will provide you with photographs and specifications for the various products that are used with SKF Microlog Inspector system and SKF MARLIN (previous generation of inspection systems).



Product compatibility

Most products listed in this catalog contain a legend that shows which SKF Microlog Inspector / SKF MARLIN systems are compatible with each product. An example of the legend is shown below. For example, a product that contains the legend below would be compatible with SKF Microlog Inspector / SKF MARLIN S-Pro models CMDM 5460 and CMDM 5660.

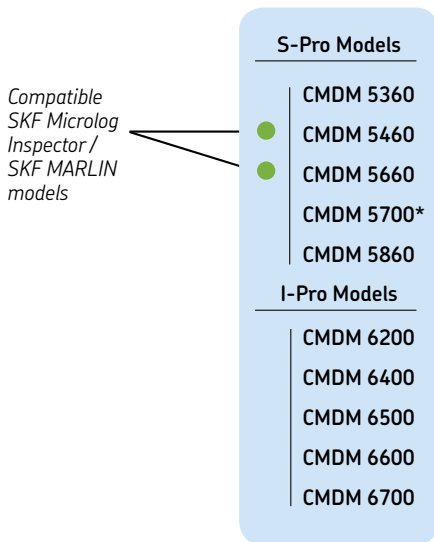

Example of compatibility legend

Note that the compatibility legend only shows which hardware systems are compatible with the accessories in this catalog; you may be using the SKF Microlog Inspector application on a different hardware system, in which case the compatibility legend would not apply.

Except where indicated, any mention of “device” within this catalog will refer to any hardware system that is running the SKF Microlog Inspector application (and not necessarily the SKF MARLIN system).

* Reference to “CMDM 5700” in the compatibility legend includes the entire CMDM 5700 series.

SKF Microlog Inspector / SKF MARLIN models

The accessories in this catalog are applicable to the following SKF Microlog Inspector / SKF MARLIN models:

SKF MARLIN **S-Pro** Inspection Systems:

- CMDM 5360
- CMDM 5460

SKF Microlog Inspector **S-Pro** System

- CMDM 5660
- CMDM 5700 series
- CMDM 5860

SKF MARLIN **I-Pro** Inspection Systems

- CMDM 6200 series
 - CMDM 6210
 - CMDM 6220*
 - CMDM 6230*
- CMDM 6400 series
 - CMDM 6410
 - CMDM 6420*
- CMDM 6500 series
 - CMDM 6510
 - CMDM 6520*
 - CMDM 6521*

SKF Microlog Inspector **I-Pro** Systems

- CMDM 6600 series
 - CMDM 6610
 - CMDM 6620*
- CMDM 6700 series
 - CMDM 6710*
 - CMDM 6720

* Indicates model is non-incendive (NI).

Note: See SKF Microlog Inspector system requirements for additional details about compatibility.

Note: Refer to the *SKF Microlog Inspector systems* section) for details about the SKF Microlog Inspector / SKF MARLIN I-Pro and S-Pro models.

Contents



Major accessories

9



Cables

25



Batteries and power accessories

33



Miscellaneous accessories

49



SKF Microlog Inspector systems

67

SKF – the knowledge engineering company

From one simple but inspired solution to a misalignment problem in a textile mill in Sweden, and fifteen employees in 1907, SKF has grown to become a global industrial knowledge leader.



Over the years we have built on our expertise in bearings, extending it to seals, mechatronics, services and lubrication systems. Our knowledge network includes 46 000 employees, 15 000 distributor partners, offices in more than 130 countries, and a growing number of SKF Solution Factories around the world.

Research and development

We have hands-on experience in over forty industries, based on our employees' knowledge of real life conditions. In addition our world-leading experts and university partners who pioneer advanced theoretical research and development in areas including tribology, condition monitoring, asset management and bearing life theory. Our ongoing commitment to research and development helps us keep our customers at the forefront of their industries.



Meeting the toughest challenges

Our network of knowledge and experience along with our understanding of how our core technologies can be combined helps us create innovative solutions that meet the toughest of challenges. We work closely with our customers throughout the asset life cycle, helping them to profitably and responsibly grow their businesses.

Working for a sustainable future

Since 2005, SKF has worked to reduce the negative environmental impact from our own operations and those of our suppliers. Our continuing technology development introduced the SKF BeyondZero portfolio of products and services which improve efficiency and reduce energy losses, as well as enable new technologies harnessing wind, solar and ocean power. This combined approach helps reduce the environmental impact both in our own operations and in our customers'.

SKF Solution Factories make SKF knowledge and manufacturing expertise available locally, to provide unique solutions and services to our customers.



Working with SKF IT and logistics systems and application experts, SKF Authorized Distributors deliver a valuable mix of product and application knowledge to customers worldwide.



Our knowledge – your success

SKF Life Cycle Management is how we combine our technology platforms and advanced services, and apply them at each stage of the asset life cycle, to help our customers to be more successful, sustainable and profitable.

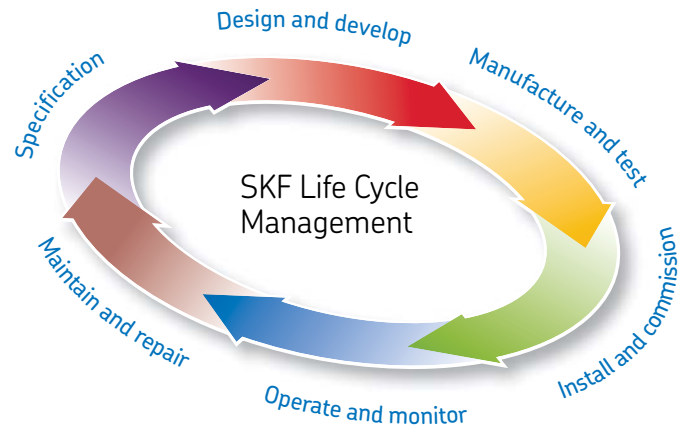

Working closely with you

Our objective is to help our customers improve productivity, minimize maintenance, achieve higher energy and resource efficiency, and optimize designs for long service life and reliability.



Bearings

SKF is the world leader in the design, development and manufacture of high performance rolling bearings, plain bearings, bearing units and housings.

Innovative solutions

Whether the application is linear or rotary or a combination of the two, SKF engineers can work with you at each stage of the asset life cycle to improve machine performance by looking at the entire application. This approach doesn't just focus on individual components like bearings or seals. It looks at the whole application to see how each component interacts with the next.



Machinery maintenance

Condition monitoring technologies and maintenance services from SKF can help minimize unplanned downtime, improve operational efficiency and reduce maintenance costs.

Design optimization and verification

SKF can work with you to optimize current or new designs with proprietary 3-D modeling software that can also be used as a virtual test rig to confirm the integrity of the design.



Sealing solutions

SKF offers standard seals and custom engineered sealing solutions to increase uptime, improve machine reliability, reduce friction and power losses, and extend lubricant life.



Mechatronics

SKF fly-by-wire systems for aircraft and drive-by-wire systems for off-road, agricultural and forklift applications replace heavy, grease or oil consuming mechanical and hydraulic systems.



Lubrication solutions

From specialized lubricants to state-of-the-art lubrication systems and lubrication management services, lubrication solutions from SKF can help to reduce lubrication related downtime and lubricant consumption.



Actuation and motion control

With a wide assortment of products – from actuators and ball screws to profile rail guides – SKF can work with you to solve your most pressing linear system challenges.

Major accessories



Wireless Machine Condition Detector (WMCD), CMVL 8000	10
Machine Condition Detector (MCD) Pro IS, CMVL 3600-IS	13
SKF MARLIN QuickConnect (MQC) stud, CMSS 2600 series	17
Infrared thermometer, CMAC 4200-K-SL	20
Handheld RFID reader, CMRF 6500 / CMRF 6700 series	22

Wireless Machine Condition Detector (WMCD)

CMVL 8000

The Wireless Machine Condition Detector (WMCD) is an SKF patented, Bluetooth enabled wireless device that captures and transmits temperature, velocity, enveloped acceleration (vibration) and Fast Fourier Transfer (FFT) data to the SKF Microlog Inspector system.

The WMCD combines with the SKF Microlog Inspector system to provide a safe, fast and easy to use system for operator inspections.

Features

- Wireless data transfer
- Measures and records:
 - Overall machine vibration (velocity)
 - Bearing vibration (enveloped acceleration)
 - Temperature
 - FFT spectral data
- Rechargeable battery
- Rugged design

Safety as a first consideration

Used with the SKF Microlog Inspector system, the WMCD increases operator safety by eliminating the hazards and inconvenience of cumbersome cables that could become tangled in equipment.

Vibration monitoring

When performing measurements, the WMCD's sensor input signal is processed to produce two vibration measurements for each measurement POINT. Velocity vibration identifies phenomena that are observable in the low to mid frequency range and indicates such structural problems as misalignment, unbalance, mechanical looseness and more.

Events that occur in the higher frequency ranges, such as bearing and gear problems, can also be detected by the WMCD with its "enveloped acceleration" capability, a signal processing technique that focuses on enhancing repetitious vibration signals that characterize such problems.



S-Pro Models

- CMDM 5360
- CMDM 5460*
- CMDM 5660
- CMDM 5700
- CMDM 5860

I-Pro Models

- CMDM 6200*
- CMDM 6400*
- CMDM 6500*
- CMDM 6600
- CMDM 6700

* Requires SKF Microlog Inspector application.

Temperature

Temperature measurements enhance the "early warning" benefit of the instrument by offering a useful indication of mechanical condition or the load applied to a specific component, since as a bearing or its lubrication fail, friction causes its temperature to rise.

Alarm capabilities

Data collected with the WMCD is wirelessly transferred to the SKF Microlog Inspector system, where it is displayed on the screen in easy to identify, color coded bars: green for acceptable, yellow for alert and red for danger. An added benefit of the WMCD is the option to connect to QuickConnect studs. The SKF MARLIN QuickConnect (MQC) studs can be used to ensure that the right data in the right spot is always collected.

FFT spectra data

While operators are collecting data on their daily routes, FFT spectra data is captured automatically with the WMCD. The FFT data is stored in the SKF Microlog Inspector system and automatically uploaded to SKF @ptitude Inspector software.

From data to useful information

The vibration data that is collected by the WMCD can be reviewed by the maintenance reliability team, allowing for more in-depth analysis and communication of machine condition data between operations, maintenance, engineering and plant management. Routine collection of vibration data during inspection rounds makes critical machine data available on a regular basis, eliminating unnecessary inspection trips and freeing up maintenance personnel to focus on scheduled repairs.

Specifications

Measurements

- Overall velocity: 10 Hz to 1 kHz (tolerances measured within the frequency range are in accordance with ISO 2954)
- Velocity (amplitude range): 0,3 to 55,0 mm/s (RMS) (0.02 to 3.00 in./s (Eq. Peak)), meets ISO Standard 10861-1
- Enveloped acceleration: 0,3 to 20,0 gE
- Enveloped acceleration band 3: 500 Hz to 10 kHz
- FFT
 - Maximum frequency:
 - Velocity: 1 000 Hz
 - Enveloped acceleration: 2 000 Hz
 - Number of lines:
 - Velocity: 400
 - Enveloped acceleration: 800
 - Averages:
 - Velocity: 2
 - Enveloped acceleration: 1
 - Window: Hanning
 - Detection type:
 - Velocity: RMS if mm/s and PK if in./s
 - Enveloped acceleration: Peak to Peak

Power

- Main power: Rechargeable Lithium battery
- Battery lifetime: Eight hours with normal usage, up to 640 points collected on one charge

Environmental

- Operating temperature: -20 to $+60$ °C (-5 to $+140$ °F)
- Operating temperature at hazardous locations: -20 to $+40$ °C (-5 to $+105$ °F)
- Storage temperature:
 - -20 to $+45$ °C (-5 to $+115$ °F) for less than one month
 - -20 to $+35$ °C (-5 to $+95$ °F) for less than six months
- Humidity: 95% non-condensing
- Dallas one wire temperature measurement: -40 to $+85$ °C (-40 to $+185$ °F)
- RTD magnet temperature measurement: -40 to $+150$ °C (-40 to $+300$ °F)

Physical

- Case: Water and dust resistant (IP 65)
- Drop test: 1,8 m (6 ft.) to concrete
- Dimensions: 76,2 × 76,2 × 76,2 mm (3.0 × 3.0 × 3.0 in.)
- Weight: 283 g (10 oz.)

Hazardous area ratings

- Non-incendive
- Class I, Division 2, Groups A, B, C, D and T6

Approvals

- CE mark and FCC

Kit contents

The CMVL 8000-K Wireless Machine Condition Detector kit contains:

- CMVL 8000: Wireless Machine Condition Detector
- CMAC 8001: Wall- or desk-mounted charging dock with international AC/DC power supply
- CMAC 8003: Belt clip
- CMAC 8004: Power supply with international plugs
- CMAC 3610: Temperature magnet probe tip (RTD)





CMVL 8000 WMCD



CMAC 8001 charging station



CMAC 8003 belt clip



CMAC 3610 temperature magnet probe tip



CMAC 8004 power supply

Optional accessories



CMSS 2600 series MQC stud



CMAC 3630 probe tip replacement kit (for CMAC 3610 temperature magnet probe tip)

Ordering information

- **CMVL 8000-K** Wireless Machine Condition Detector kit, includes WMCD, belt clip, temperature magnet (RTD) and charging dock.

Optional accessories

- **CMAC 3610:** Temperature magnet probe tip
- **CMAC 3630:** Probe tip replacement kit
- **CMAC 8001:** Charging station with international DC power supply
- **CMAC 8003:** Belt clip
- **CMAC 8004:** Replacement international DC power supply for use with charging station
- SKF MARLIN QuickConnect (MQC) studs:
 - **CMSS 2600-3:** Mechanical M8 × 1,25 mounting thread, three studs per package
 - **CMSS 2610-3:** Mechanical 1/4-28 mounting thread, three studs per package

Machine Condition Detector Pro IS

CMVL 3600-IS

The SKF Machine Condition Detector Pro IS (MCD Pro IS) is a rugged, handheld analysis tool that captures and displays temperature, velocity and enveloped acceleration (vibration) and alarms.

The MCD Pro IS is certified Intrinsically Safe (IS) for use in hazardous environments that require either a Zone I or Class I, Division I rating.

The MCD Pro IS collects and displays velocity, acceleration enveloping and temperature data with general alarm capabilities.

Features

- Extremely rugged design
- Easy to use
- Stand alone use or as part of a system
- Six alarm settings
- Color alarm displays

Go / No-go machine monitoring

The MCD Pro IS is designed to provide a straightforward approach to machinery monitoring. The instrument's sensor affixes to a machine point via a SKF MARLIN QuickConnect (MQC) stud or magnetic base for automatic collection of vibration and temperature data. Green, yellow and red LEDs provide easy to interpret indications of machine status, so operations or maintenance personnel can quickly identify the need for more in-depth analysis on a particular machine.

Multi-parameter monitoring capabilities

The MCD Pro IS operates as a stand-alone device or as an integral component of the complete SKF Microlog Inspector / SKF MARLIN System.

By pairing the MCD Pro IS with the SKF Microlog Inspector / SKF MARLIN handheld device, important machinery and process information may be stored for trending review. Data can also be transferred with the SKF system from the MCD Pro IS to @ptitude Inspector software for further detailed analysis.



S-Pro Models

- CMDM 5360
- CMDM 5460
- CMDM 5660
- CMDM 5700
- CMDM 5860

I-Pro Models

- CMDM 6200
- CMDM 6400
- CMDM 6500
- CMDM 6600
- CMDM 6700

Vibration monitoring

When performing measurements, the MCD Pro IS's sensor input signal is processed to produce two vibration measurements for each measurement POINT. Velocity vibration identifies phenomena that are observable in the low to mid frequency range and indicates such structural problems as misalignment, unbalance, mechanical looseness and more. Events that occur in the higher frequency ranges, such as bearing and gear problems, can also be detected by the MCD Pro IS with its "acceleration enveloping" capability, a signal processing technique that focuses on enhancing the repetitious vibration signals that characterize such problems.

Temperature

Temperature measurements enhance the "early warning" benefit of the instrument by offering a useful indication of mechanical condition or the load applied to a specific component, since as a bearing or its lubrication fails, friction causes its temperature to rise.

General alarm capabilities

When used as a stand-alone tool, the MCD Pro IS may be easily programmed for six alarm settings, which include the "alert" and "danger" levels for each of the three measurements.

When measurements are taken, current measured values are automatically compared to six user-defined settings, and the MCD Pro IS's alarm indicator and LEDs react appropriately. An "alert" condition provides the user with an early warning of impending problems for which immediate in-depth analysis should be performed. A "danger" alarm indicates that a problem has escalated to a point where actions must be made quickly to avoid a serious failure.

When used with the SKF Microlog Inspector / SKF MARLIN, data is logged for trending and percent change from last measurement and baseline data.

SKF MARLIN QuickConnect (MQC) studs for quality, repeatable data collection

Specially designed mechanical and computerized studs enable users to collect consistent, accurate and repeatable data from each measurement point. Engineered to work exclusively with the MCD Pro IS, the MQC mechanical and computerized studs provide for a fast, quarter-turn connection that temporarily fastens the probe to a measurement point. This reduces the possibility of errors and inconsistencies often resulting from data collected by using varying methodologies.

Specifications

Measurements

- Vibration pickup: Integrated piezoelectric acceleration (ceramic, shear type)
- Measurement range:
 - Velocity: 0,3 to 55,0 mm/s (RMS) (0.02 to 3.00 in./s (Eq. Peak)), meets ISO Standard 10861-1
 - Enveloped acceleration: 0,3 to 20,0 gE
 - Temperature: 0 to 100 °C (30 to 210 °F)
- Frequency range:
 - Overall velocity: 10 Hz to 1 kHz (tolerances measured within the frequency range are in accordance with ISO 3945)
 - Acceleration enveloping band 3: 500 Hz to 10 kHz

Power

- Main power: Two 1,5 V alkaline AA batteries
- Battery lifetime: 30 hours
- Backup battery: One 3 V BR1225 Lithium-ion battery
- Auto off: Two minute countdown on last operation

Environmental

- Operating temperature:
 - Ordinary locations: -20 to +60 °C (-5 to +140 °F)
 - Hazardous locations: -20 to +40 °C (-5 to +105 °F)
- Storage temperature: -35 to +70 °C (-30 to +160 °F)
- Humidity: 5 to 95% non-condensing

Physical

- Case: Water and dust resistant (IP 65)
- Drop test: 1,8 m (6 ft.) on multiple axes
- Dimensions: 190,5 × 43,2 × 41,4 mm (7.50 × 1.70 × 1.63 in.)
- Weight: 431 g (0.95 lb.) with battery, 635 g (1.4 lb.) with temperature magnet probe tip
- Display viewing area: 54,99 × 17,78 mm (2.165 × 0.700 in.)
- Communications port type: Micro D RS-232
- QuickConnect interface
 - Receptacle: Quarter-turn 5/8-24 two-lead thread with contact
 - Accessories to fit:
 - CMSS 26xx: MQC QuickConnect stud series
 - Temperature magnet
 - CMSS 60139-04: 10 cm (4 in.) stinger

Hazardous area ratings

- Intrinsic Safety (IS):
 - ATEX: II1G EEx ia IIC T4 (T_a = -20 to +40 °C (-5 to +105 °F))
Class I, Division 1, Groups A, B, C, D, T3A (USA, Canada)

Kit contents

Each CMVL 3600-IS-K-01-C MCD Pro IS kit consists of the following items:

- CMVL 3600-IS: MCD Pro IS probe
- CMAC 3610: Temperature magnet probe tip
- CMAC 3620: MCD Pro IS setup key
- CMAC 3625: Carrying case
- CMAC 3640 Protective cover
- Two AA alkaline batteries
- CMVL 3600M-SL: User Manual
- CMVL 3600-QS: Quick Start card
- Vibration severity card

CMVL 3600-IS MCD Pro IS probe



CMAC 3625 carrying case





CMAC 3610 temperature magnet probe tip



CMAC 3620 setup key



CMAC 3640 Protective cover

Envelope Severity of Peak-to-Peak	Shaft Diameter and Speed		
	Diameter Between 200 and 300 mm and Speed <math>< 1000 \text{ rpm}</math>	Diameter Between 50 and 300 mm and Speed Between 100 and 1000 rpm	Diameter Between 20 and 150 mm and Speed Between 100 and 1000 rpm
0.1	Unacceptable (Danger)	Unacceptable (Danger)	Unacceptable (Alert)
0.2	Unacceptable (Alert)	Unacceptable (Alert)	Satisfactory
0.3	Satisfactory	Satisfactory	Satisfactory
0.4	Good	Good	Good

Velocity Severity ISO 50816-3 inches per Peak	mm/sec RMS	Machinery Group 2 (Medium Machines) Rated Power: 15 kW to 300 kW Electrical Machines with Shaft Height 160 to 315 mm (6.30 to 12.40 in.)	Machinery Group 1 (Large Machines) Rated Power: >300 kW Electrical Machines with Shaft Height >315 mm (>12.40 in.)	
		Unacceptable (Danger)	Unacceptable (Alert)	Unacceptable (Alert)
0.01	0.01	Unacceptable (Danger)	Unacceptable (Alert)	Unacceptable (Alert)
0.02	0.02	Unacceptable (Alert)	Unacceptable (Alert)	Satisfactory
0.03	0.03	Satisfactory	Satisfactory	Satisfactory
0.04	0.04	Satisfactory	Satisfactory	Satisfactory
0.05	0.05	Satisfactory	Satisfactory	Satisfactory
0.06	0.06	Good	Good	Good
0.07	0.07	Good	Good	Good
0.08	0.08	Good	Good	Good
0.09	0.09	Good	Good	Good
0.10	0.10	Good	Good	Good

Vibration severity card (front and back)

Optional accessories

Note: When the CMAC 6109 cable and CMAC 6115 adapter are used with the MCD Pro IS, the complete system is not ATEX or IECEx certified and may only be used in **non-hazardous areas**.



CMAC 6109 cable (for CMDM 5660 / CMDM 5460 S-Pro kits – requires CMAC 6115 adapter)



CMAC 6115 snap-on adapter (for CMDM 5660 / CMDM 5460 S-Pro kits)



CMAC 3611 magnetic tip



CMAC 6141 cable (for CMDM 6600 / CMDM 6500 I-Pro kits – requires CMAC 6142 adapter) (for CMDM 6700 I-Pro kits – requires CMAC 6159 adapter)



CMAC 6142 snap-on adapter (for CMDM 6600 / CMDM 6500 I-Pro kits)



CMAC 6159 snap-on adapter (for CMDM 6700 I-Pro kits)



CMSS 2600 series MQC stud



CMAC 9600 series tools

CMSS 60139 series stinger



CMAC 6107 cable (for CMDM 6200 / CMDM 6400 I-Pro kits)



Ordering information

- CMVL 3600-IS-K-01-C Machine Condition Detector (MCD) Pro IS kit.

Optional accessories

- CMAC 3610: Temperature magnet probe tip
- CMAC 3611: Magnetic tip
- CMAC 3620: MCD Pro IS setup key
- CMAC 3630: Probe tip replacement kit for CMAC 3610 temperature magnet probe tip
- CMAC 3640: Protective cover (package of 10)
- CMAC 6107: Cable, SKF MARLIN I-Pro to MCD Pro IS
- CMAC 6109: Cable, SKF MARLIN S-Pro to MCD Pro IS (requires CMAC 6115 snap-on adapter)
- CMAC 6115: Snap-on adapter, SKF MARLIN S-Pro to CMAC 6109 cable
- CMAC 6141: Cable, SKF MARLIN I-Pro to MCD Pro IS (requires CMAC 6142 snap-on adapter for CMDM 6600 / CMDM 6500 I-Pro kits or CMAC 6159 snap-on adapter for CMDM 6700 I-Pro kit)
- CMAC 6142: Snap-on adapter, SKF MARLIN I-Pro to CMAC 6141 cable
- CMAC 6159: Snap-on adapter, RS 232, SKF MARLIN I-Pro CMDM 6700 to CMAC 6141 cable
- CMSS 60139-04: Stinger, 10,2 cm (4 in.), 1/4-28 mounting (requires CMSS 2610-3 SKF MARLIN QuickConnect)
- CMSS 60139-06: Stinger, 15,2 cm (6 in.), 1/4-28 mounting (requires CMSS 2610-3 SKF MARLIN QuickConnect)
- CMSS 60139-12: Stinger, 30,5 cm (12 in.), 1/4-28 mounting (requires CMSS 2610-3 SKF MARLIN QuickConnect)

SKF MARLIN QuickConnect (MQC) and mounting accessories

- CMSS 2600-3: MQC mechanical, M8 × 1,25 mounting thread, three studs per package
- CMSS 2610-3: MQC mechanical, 1/4-28 mounting thread, three studs per package
- CMSS 2601-3: MQC computerized, M8 × 1,25 mounting thread, three studs per package
- CMSS 2611-3: MQC computerized, 1/4-28 mounting thread, three studs per package
- CMAC 9600-01: Toolkit for spot face 1/4-28
- CMAC 9600-02: Toolkit for spot face M8 × 1,25
- CMAC 9600-03: Drill bit for 1/4-28 kit
- CMAC 9600-04: Tap for 1/4-28 kit
- CMAC 9600-05: Pilot for 1/4-28 kit
- CMAC 9600-06: Drill bit for M8 × 1,25 kit
- CMAC 9600-07: Tap for M8 × 1,25 kit
- CMAC 9600-08: Pilot for M8 × 1,25 kit
- CMAC 9600-09: End mill or counter bore for either kit
- CMAC 9600-10: Toolkit for spot face M6 × 1,25



CMAC 3630 probe tip replacement kit (for CMAC 3610 temperature magnet probe tip)

SKF MARLIN QuickConnect (MQC) Stud

CMSS 2600 series

Overview

The SKF MARLIN QuickConnect (MQC) stud ensures accurate and dependable data collection, and in its “smart” version provides measurement point identification and point-specific alarm control for the Machine Condition Detector (MCD) probe. The MQC stud is also used with the Wireless Machine Condition Detector (WMCD) for point identification.

The MQC is a small, stud-like device that mounts permanently to a machine measurement point, typically a bearing cap. The WMCD/MCD probe connects quickly and securely to the installed MQC stud by a simple quarter turn (hence the name, QuickConnect). When collecting data, this mounting method helps ensure proper probe location and orientation and provides for repeatable and accurate measurements, especially for higher frequency rolling element bearing defect and gear vibration signals.

Computerized stud

In addition to providing a secure mechanical interface between the WMCD/MCD probe and the measured machine, the patented MQC computerized stud houses a memory chip and a temperature sensor. The chip has an ample 256 bits of memory and is programmable for point ID information (for automatic point identification). When used with the MCD, the MQC studs store six alarms specific to the monitored point, i.e., an alert and a danger setpoint for each of three MCD measurements performed at the point (velocity vibration, enveloped acceleration vibration and temperature). The chip also stores the last measurement reading with a date/timestamp for instant, in-the-field trending.

The MQC stud temperature indication range is 0 to 85 °C (30 to 185 °F) and it provides a trendable indication of temperature.

When monitoring different types of machines, mount computerized studs on machine bearings and other points of interest, and use the SKF Microlog Inspector / SKF MARLIN handheld device to set each POINT's measurement alarm points in the MQC's memory.



SKF MARLIN QuickConnect (MQC) stud and SKF Machine Condition Detector (MCD)



Installed SKF MARLIN QuickConnect (MQC) stud with protective cap

Mechanical stud

The MQC mechanical stud does not house a programmable memory. It is a mechanical interface only, used to help ensure proper probe location and orientation, and to attain the best possible measurement quality for periodic monitoring purposes.

Data collection

During data collection, when the MCD probe is connected and measurements performed:

- The MQC computerized stud's six alarm setpoints and the values with date/timestamp of the previous reading are temporarily uploaded into the MCD's memory.
- In the MCD, the POINT's current measurement values are compared to the POINT's alarm setpoints, and MCD alarm lights (green/yellow/red LED) and LCD indicators react appropriately. For comparison/trending, the previous readings can be displayed with the MCD Mode button.

Installation

Detailed installation instructions are provided with each MQC package.

- 1 Prepare surface.** Within a 50 mm (2 in.) square area, prepare a flat surface and clean with a hand tool.
- 2 Drilling.** Drill a pilot hole with a 6,7 mm drill bit for the M8 × 1,25 thread or a #3 drill for the 1/4-28 thread, then enlarge the pilot hole with the drill bit (M8 × 1,25 or 1/4-28).
- 3 Insert pilot.** Insert the pilot (M8 × 1,25 or 1/4-28) into the counter bore.
- 4 Spot face mounting area.** Using the piloted counter bore, spot face the surface until smooth and approximately 25 mm (1 in.) in diameter.
- 5 Tap hole.** Use the tap (M8 × 1,25 or 1/4-28) to hand tap the hole to the desired thread depth.
- 6 Mount MQC stud.** Mount and tighten the MQC stud to 2,0 Nm (24 in. lb.); Loctite or equivalent is recommended.



Dimensions

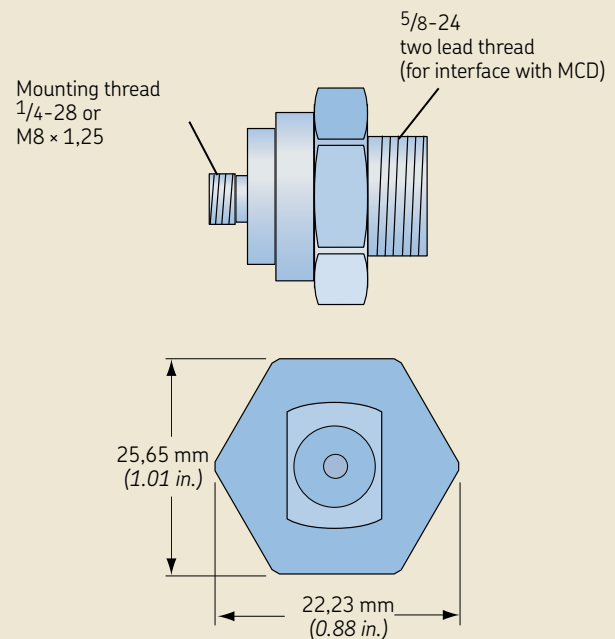

Kit contents

The mechanical and computerized MQC studs are available in both Imperial and Metric mounting thread configurations and are sold three to a package. Each kit includes:

- Three SKF MARLIN QuickConnect studs
- Three molded protection caps
- Installation instruction sheet

The maximum storage temperature for the smart MQC is 120 °C (250 °F). Toolkits for spot facing, drilling and tapping are also available in two configurations (for 1/4-28 mounting or M8 × 1,25 mounting). Additional drill bits, end mills and taps are also available.



CMSS 2600 series MQC



Protection cap

Optional accessories



CMAC 9600 series toolkit

Ordering information

Mechanical studs:

- CMSS 2600-3 SKF MARLIN QuickConnect mechanical stud, M8 × 1,25 mounting thread (package of three)
- CMSS 2610-3 SKF MARLIN QuickConnect mechanical stud, 1/4-28 mounting thread (package of three)

Computerized studs:

- CMSS 2601-3 SKF MARLIN QuickConnect computerized stud, M8 × 1,25 mounting thread (package of three)
- CMSS 2611-3 SKF MARLIN QuickConnect computerized stud, 1/4-28 mounting thread (package of three)

Optional accessories

- CMAC 9600-01: Toolkit for spot face 1/4-28
- CMAC 9600-02: Toolkit for spot face M8 × 1,25
- CMAC 9600-03: Drill bit for 1/4-28 kit
- CMAC 9600-04: Tap for 1/4-28 kit
- CMAC 9600-05: Pilot for 1/4-28 kit
- CMAC 9600-06: Drill bit for M8 × 1,25 kit
- CMAC 9600-07: Tap for M8 × 1,25 kit
- CMAC 9600-08: Pilot for M8 × 1,25 kit
- CMAC 9600-09: End mill or counter bore for either kit
- CMAC 9600-10: Toolkit for spot face M6 × 1,25

Infrared Thermometer

CMAC 4200-K-SL

The SKF CMAC 4200-K-SL infrared thermometer with laser sighting is a rugged, easy to use, portable, non-contact thermometer. Ideal for a broad range of maintenance tasks, the CMAC 4200-K-SL may be connected directly to the SKF Microlog Inspector / SKF MARLIN for quick, accurate recording of surface temperatures. It is one of a variety of accessories offered by SKF to help enhance the overall effectiveness of a predictive maintenance program.

The CMAC 4200-K-SL measures the amount of infrared energy emitted by an object and converts it to a display of the object's surface temperature.



S-Pro Models

- CMDM 5360
- CMDM 5460
- CMDM 5660
- CMDM 5700
- CMDM 5860

I-Pro Models

- CMDM 6200
- CMDM 6400
- CMDM 6500
- CMDM 6600
- CMDM 6700

Features

- Designed for physically challenging environments
- Easy to use
- Adjustable emissivity with on-board table
- Fast response time
- Accuracy $\pm 1\%$ of reading
- Wide temperature range

Graphic display

View more information at a glance. The CMAC 4200-K-SL infrared thermometer automatically creates a graphic display of the last 10 temperature points measured using the maximum and minimum temperature values to establish the range.

Graphic display

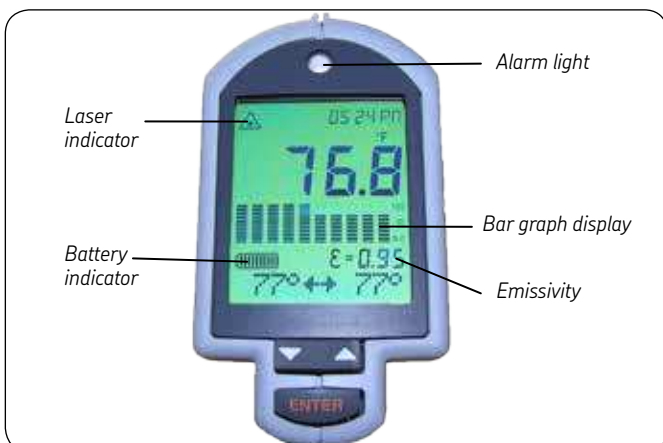

Specifications

- Temperature range: -30 to $+900$ °C (-25 to $+1600$ °F)
- Display resolution: $0,1$ °C (0.2 °F)
- Accuracy:
 - $\pm 1\%$ of reading, or ± 1 °C (± 2 °F), whichever is greater at 23 °C (73 °F)
 - ± 2 °C (± 4 °F) for targets below 0 °C (32 °F)
- Repeatability: $\pm 0,5\%$ of reading, or ± 1 °C (± 2 °F)
- Response time (95%): 250 ms
- Spectral response: 8 to 14 μm
- Optical resolution: 60:1
- Ambient operating range: 0 to 50 °C (30 to 120 °F); Laser maximum 45 °C (115 °F)
- Relative humidity: 10 to 95%, non-condensing at up to 30 °C (85 °F)
- Storage temperature: -20 to $+50$ °C (-5 to $+120$ °F) without battery
- Analog output: 1 mV/°C ($mV/°F$)
- Power: Two 1,5 volt alkaline AA batteries
- Tripod mount: $1/4$ -20 UNC
- Dimensions: $200 \times 170 \times 50$ mm ($7.9 \times 6.7 \times 2.0$ in.)
- Weight: 480 g (22 oz.)

Kit contents

- CMAC 4200: Infrared thermometer
- Nylon belt holster
- Hard carrying case
- Operator's guide



CMAC 4200 infrared thermometer



Nylon belt holster

Optional accessories



CMAC 6148 temperature gun interface cable (for CMDM 6600 / CMDM 6500 I-Pro kits – requires CMAC 6142 adapter) (for CMDM 6700 I-Pro kits – requires CMAC 6159 adapter)



CMAC 6142 snap-on adapter (for CMDM 6600 / CMDM 6500 I-Pro kits)



CMAC 6159 snap-on adapter (for CMDM 6700 I-Pro kits)



CMAC 6108 temperature gun interface cable (for CMDM 6200 and CMDM 6400 I-Pro kits)

Ordering information

- **CMAC 4200-K-SL** Infrared thermometer with adapter, operator's guide, nylon holster and hard carrying case.

Optional accessories

- **CMAC 6108** Temperature gun interface cable, to CMDM 6200 / CMDM 6400
- **CMAC 6148** Temperature gun interface cable to CMDM 6500 / CMDM 6600 / CMDM 6700 (CMDM 6500 / CMDM 6600 I-Pro kits require CMAC 6142 adapter; CMDM 6700 I-Pro kit requires CMAC 6159 adapter)
- **CMAC 6142** Snap-on adapter for CMDM 6500 / CMDM 6600 I-Pro kit
- **CMAC 6159** Snap-on adapter, RS 232, for CMDM 6700 I-Pro kit

Handheld RFID Reader

CMRF 6500 / CMRF 6700 series



The SKF CMRF 6500 and CMRF 6700 series of handheld RFID readers are cost-effective, compact solutions for adding mobile RFID capability to SKF's latest generation of mobile computers. These RFID readers bring the power of RFID to your company's asset tracking and Operator Driven Reliability (ODR) programs. When combined with SKF's powerful mobile computers, the CMRF 6500 / CMRF 6700 RFID reader provides the user exceptional point identification capabilities with pinpoint location accuracy for critical asset tracking.

Features

- Easy snap-on installation
- Lightweight, ergonomic design with Bluetooth connection
- Non-incendive (NI) model for use in hazardous areas
- Both RFID and barcode tag identification may be combined

The combination of the RFID reader and the mobile computer offer RFID and barcode reading that out dates simple "either/or" coexistence with a complementary solution that uses both identification methods. The CMRF 6500 / CMRF 6700 delivers the needed flexibility to not only read RFID, but also barcodes from virtually any angle, near or far, within the same SKF Microlog Inspector application.

When harsh, hazardous environments make RFID the preferred asset identification method, and non-incendive (NI) certification is required, the CMRF 6520 / CMRF 6700, combined with the SKF Microlog Inspector CMDM 6620, provides a certified system for reading RFID tags.

Specifications

The SKF CMRF 6510 and CMRF 6520 series RFID readers are compatible with SKF Microlog Inspector models CMDM 6610 and CMDM 6620, as well as SKF MARLIN models CMDM 6510, CMDM 6520 and CMDM 6521 and SKF MARLIN firmware version 4.5.

The CMRF 6700 series RFID readers are compatible with the CMDM 6700 series SKF Microlog Inspector.

* The CMDM 6700 series SKF Microlog Inspector is also available with an integrated RFID reader.

S-Pro Models

CMDM 5360
CMDM 5460
CMDM 5660
CMDM 5700
CMDM 5860

I-Pro Models

CMDM 6200
CMDM 6400
● CMDM 6500
● CMDM 6600
● CMDM 6700

Measurements

- Field
 - 70° cone (approximate) measured from nose of device
 - Typical read range (tag dependent):
6,1 to 304,8 cm (0.2 to 10,0 ft.)
 - Output power:
 - USA: 1 W (4 W EIRP)
 - Europe: 0,5 W
- Indicator LEDs:
 - Five indicator LEDs: SmartSystems – Power / Ready to work, Data transfer to host, RF on, Tag read and Battery status

Power

- Removable Lithium-ion battery pack

Environmental

- Operating temperature: 0 to 50 °C (30 to 120 °F)
- Storage temperature: -30 to +70 °C (-20 to +160 °F)
- Humidity: 10 to 95% (non-condensing)
- Enclosure: IP 64 compliant
- Shock: 30 G, 11 ms, half sine pulse (operating)
- Vibration: Quasi random vibration 17,5 G RMS for two hours, each of three axis
- Drop survival: Withstands 1,3 m (4 ft.) drop, 26 times to concrete
- Hazardous locations:
 - Non-incendive (NI) option (model CMRF 6520 and CMRF 6700 series):
 - Class I, Division 2, Groups A, B, C, D
 - Class II, Division 2, Groups F, G
 - Class III, Division 2
 - T4 (model CMRF 6500 series); T6 (model CMRF 6700 series)
- CE rated (model CMRF 6510)

Physical

- Weight without handheld SKF MARLIN: 430 g (15.4 oz.) with battery
- Weight with SKF Microlog Inspector / SKF MARLIN CDM 6500 portable computer: 860 g (1.9 lbs.) with battery

Tag air interfaces

- EPC global UHF Gen 2
- ISO 18000-6b
- ISO 18000-6c

RFID tags

SKF offers rigid, reusable RFID tags that are compatible with the CDM 6700 SKF Microlog Inspector with integrated RFID reader and the CMRF 6500 / CMRF 6700 series of RFID readers. These tags provide superior performance on a variety of surfaces and have an impressive range with a rugged encapsulation, yet compact design, which is suitable for harsh industrial applications. The tags utilize Gen 2 silicon supporting 512 bits of user memory and have an IP rating of IP67. They have rugged multi-mounting options for ease of installation.

SKF offers a large global radio tag (CMAC 6181) and two different low profile tags, one tuned for FCC regions (CMAC 6182) and one tuned for ETSI regions (CMAC 6183). See **page 66** for details.

CMAC 6181

CMAC 6181 is designed to provide both edge and normal reading performance for enhanced portal and forklift RFID applications. With a range of up to 6 m (20 ft.), CMAC 6181 is suitable for harsh environments and meets global standards.

- CMAC 6181: Large, rugged, long range, global radio, RFID tag, 94,5 × 72,4 mm (3.72 × 2.85 in.)

CMAC 6182 and CMAC 6183

CMAC 6182 and CMAC 6183 are low profile tags within a small, durable form factor. They are suitable for tracking a wide variety of assets and are optimized specifically for metal surfaces such as metal pallets, unit load devices and other metal assets.

CMAC 6182 is tuned for FCC regions, while CMAC 6183 is tuned for ETSI regions (Europe).

- CMAC 6182: Low profile, rugged, FCC radio, RFID tag, 111,5 × 21,8 mm (4.39 × 0.86 in.)
- CMAC 6183: Low profile, rugged, global ETSI radio, RFID tag, 111,5 × 21,8 mm (4.39 × 0.86 in.)

CMAC 6147 universal power supply



CMVL 3351 power cord



CMAC 6145 two-bay charger



Kit contents

The CMRF 6510-B3002, CMRF 6520-B6004, CMRF 6530-xxxxx, CMRF 6710-BA002, CMRF 6720-BA004 and CMRF 6730-BA0xx kits contain:

- RFID reader
- CMAC 6147: Universal power supply
- CMVL 3351: Power cord
- CMAC 6145: Two-bay charger
- Battery
- User manual



CMRF 6500 / CMRF 6700 series RFID reader

Optional accessories



CMAC 6143 battery (for use in CMRF 6510, CMRF 6710, CMRF 6530 and CMRF 6730 only)



CMAC 6144 NI battery (for use in the CMRF 6520 and CMRF 6720 only)



CMAC 6181 large, rugged, long range RFID tag



CMAC 6182 low profile, rugged RFID tag (FCC radio)



CMAC 6183 low profile, rugged RFID tag (ETSI radio)

Ordering information

For use with CDM 6600 series SKF Microlog Inspector:

- **CMRF 6510-B3002** Handheld RFID reader, CE certified.
- **CMRF 6520-B6004** Handheld RFID reader, Class I, Division 2, Groups A, B, C, D; Class I, Division 2, Groups F, G; Class III, Division 2, T4 certified.
- **CMRF 6530-xxxxx** Handheld RFID reader, requires country specific Radio Code; contact your local SKF Representative for complete model number for your area. No CE mark, not Class I, Division 2.

For use with CDM 6700 series SKF Microlog Inspector:

- **CMRF 6710-BA002** Handheld RFID reader, CE certified.
- **CMRF 6720-BA004** Handheld RFID reader, Class I, Division 2 certified.
- **CMRF 6730-BA0xx** Handheld RFID reader, requires country specific Radio Code; contact your local SKF Representative for complete model number for your area. Specify radio code (xx); radio options are available for North America, Hong Kong, China, Taiwan, Australia, Thailand, New Zealand, Brazil, Malaysia, Singapore, Philippines and Israel.

- **CMAC 6181-10** Large, rugged, long range, global radio RFID tag (package of 10 tags).
- **CMAC 6181-250** Large, rugged, long range, global radio RFID tag (package of 250 tags).
- **CMAC 6182-10** Low profile, rugged, FCC radio RFID tag (package of 10 tags).
- **CMAC 6182-250** Low profile, rugged, FCC radio RFID tag (package of 250 tags).
- **CMAC 6183-10** Low profile, rugged, global ETSI radio RFID tag (package of 10 tags).
- **CMAC 6183-250** Low profile, rugged, global ETSI radio RFID tag (package of 250 tags).

Optional accessories

- **CMVL 3351:** Power cord
- **CMAC 6143:** Spare battery for use in CMRF 6510 and CMRF 6530 only
- **CMAC 6144:** Spare NI battery for use in CMRF 6520 only
- **CMAC 6145:** Two-bay charger
- **CMAC 6147:** Universal power supply

Cables



Cable recommendations and compatibility	26
BNC cable, VibPak to accelerometer, CMAC 3714	27
Cable, SKF I-Pro to VibPak, CMAC 3725	27
USB communication cable, docking station to PC, CMAC 6104	28
USB communication cable, docking station to PC, CMAC 6163	28
Cable, SKF I-Pro to MCD Pro IS, CMAC 6107	29
Cable, SKF I-Pro to infrared thermometer gun, CMAC 6108	29
Cable, SKF S-Pro to MCD Pro IS, CMAC 6109	30
Snap-on adapter, SKF S-Pro to CMAC 6109 cable, CMAC 6115	30
Cable, SKF I-Pro to MCD Pro IS or VibPak, CMAC 6141	31
Snap-on adapter, SKF I-Pro to CMAC 6141 cable, CMAC 6142	31
Snap-on adapter, SKF I-Pro CMDM 6700 to CMAC 6141 cable, CMAC 6159	32
Cable, SKF I-Pro to infrared thermometer gun, CMAC 6148	32

Cable recommendations and compatibility

The following tables show which cables are recommended for the various accessories found in this catalog and the cables that are compatible with the different models of the SKF Microlog Inspector and SKF MARLIN systems. The pages that follow describe each of the cables listed below.

Cables recommended for SKF Microlog Inspector / SKF MARLIN accessories

Accessory model number	Accessory description	CMAC 3714	CMAC 3725	CMAC 6107	CMAC 6108	CMAC 6109	CMAC 6141	CMAC 6148
CMAC 4200	Infrared thermometer kit (with CMDM 6200 and CMDM 6400 series)				●			
CMAC 4200	Infrared thermometer kit (with CMDM 6500 and CMDM 6600 series)							●
CMVL 3600-IS	MCD Pro IS (with CMDM 5360, CMDM 5460, CMDM 5660 and CMDM 5860)					●		
CMVL 3600-IS	MCD Pro IS (with CMDM 6200 and CMDM 6400 series)			●				
CMVL 3600-IS	MCD Pro IS (with CMDM 6500 and CMDM 6600 series)						●	
CMVL 3700	VibPak (with CMDM 6200 and CMDM 6400 series)	●	●					
CMVL 3700	VibPak (with CMDM 6500 and CMDM 6600 series)	●					●	

Cables compatible with SKF Microlog Inspector and SKF MARLIN systems

SKF Microlog Inspector and SKF MARLIN system model numbers	CMAC 3714	CMAC 3725	CMAC 6104	CMAC 6107	CMAC 6108	CMAC 6109	CMAC 6141	CMAC 6148	CMAC 6163
S-Pro Models									
CMDM 5360 series			●			●			
CMDM 5460 series			●			●			
CMDM 5660 series			●			●			
CMDM 5700 series									●
CMDM 5860 series			●			●			
I-Pro Models									
CMDM 6200 series	●	●	●	●	●				
CMDM 6400 series	●	●	●	●	●				
CMDM 6500 series	●		●				●	●	
CMDM 6600 series	●		●				●	●	
CMDM 6700 series							●	●	●

CMAC 3714

BNC cable, VibPak to accelerometer

The CMAC 3714 BNC cable is used to connect the VibPak (CMVL 3700) to the accelerometer (CMSS 2200).

Specifications

- Connectors: BNC to two pin MIL
- Length: 76,2 cm (30 in.) coiled

S-Pro Models

CMDM 5360
CMDM 5460
CMDM 5660
CMDM 5700
CMDM 5860

I-Pro Models

- CMDM 6200
- CMDM 6400
- CMDM 6500
- CMDM 6600
- CMDM 6700



Ordering information

- **CMAC 3714** BNC cable, VibPak to accelerometer.

CMAC 3725

Cable, SKF I-Pro to VibPak

The CMAC 3725 cable is used to connect the CMDM 6200 and CMDM 6400 series SKF I-Pro to the VibPak (CMVL 3700).

Specifications

- Connectors: Micro D RS-232 to mini-serial nine pin male
- Length: 16,5 cm (6.5 in.)

S-Pro Models

CMDM 5360
CMDM 5460
CMDM 5660
CMDM 5700
CMDM 5860

I-Pro Models

- CMDM 6200
- CMDM 6400
- CMDM 6500
- CMDM 6600
- CMDM 6700



Ordering information

- **CMAC 3725** Cable, SKF MARLIN (CMDM 6200 / CMDM 6400 series) to VibPak.

CMAC 6104

USB communication cable, docking station to PC

The CMAC 6104 cable is used to connect the docking station to the PC.

Specifications

- Connectors: USB Type A to USB Type B
- Length: 1,8 m (6 ft.) straight

S-Pro Models

- CMDM 5360
- CMDM 5460
- CMDM 5660
- CMDM 5700
- CMDM 5860

I-Pro Models

- CMDM 6200
- CMDM 6400
- CMDM 6500
- CMDM 6600
- CMDM 6700



Ordering information

- **CMAC 6104** USB communication cable, SKF MARLIN docking station to PC.

CMAC 6163

USB communication cable, docking station to PC

The CMAC 6163 cable is used to connect the CMAC 6160 docking station to the host PC.

Specifications

- Connectors: USB Type A to Micro USB Type B
- Length: 1,8 m (6 ft.) straight

S-Pro Models

- CMDM 5360
- CMDM 5460
- CMDM 5660
- CMDM 5700
- CMDM 5860

I-Pro Models

- CMDM 6200
- CMDM 6400
- CMDM 6500
- CMDM 6600
- CMDM 6700



Ordering information

- **CMAC 6163** USB communication cable, CMAC 6160 or CMAC 6169 docking station to PC.

CMAC 6107

Cable, SKF I-Pro to MCD Pro IS

The CMAC 6107 cable is used to connect the CMDM 6200 and CMDM 6400 series SKF I-Pro to the MCD Pro IS (CMVL 3600-IS).

Specifications

- Connectors: Micro D RS-232 to mini-serial nine pin male
- Length: 61,0 cm (2 ft.) coiled

S-Pro Models

CMDM 5360
CMDM 5460
CMDM 5660
CMDM 5700
CMDM 5860

I-Pro Models

- CMDM 6200
 - CMDM 6400
- CMDM 6500
CMDM 6600
CMDM 6700

CMAC 6108

Cable, SKF I-Pro to infrared thermometer gun

The CMAC 6108 cable is used to connect the CMDM 6200 and CMDM 6400 series SKF I-Pro to the wired infrared thermometer gun (CMAC 4200).

Specifications

- Connectors: Micro D RS-232 to output adapter
- Length: 61,0 cm (2 ft.) coiled

S-Pro Models

CMDM 5360
CMDM 5460
CMDM 5660
CMDM 5700
CMDM 5860

I-Pro Models

- CMDM 6200
 - CMDM 6400
- CMDM 6500
CMDM 6600
CMDM 6700



Ordering information

- **CMAC 6107** Cable, SKF MARLIN (CMDM 6200 / CMDM 6400 series) to MCD Pro IS.



Ordering information

- **CMAC 6108** Cable, SKF MARLIN (CMDM 6200 / CMDM 6400 series) to infrared thermometer gun.

CMAC 6109

Cable, SKF S-Pro to MCD Pro IS

The CMAC 6109 cable is used to connect the SKF S-Pro to the MCD Pro IS (CMVL 3600-IS).

Note: This cable requires the CMAC 6115 snap-on adapter.

Specifications

- Connectors: Serial 15 pin male to mini-serial nine pin male
- Length: 76,2 cm (30 in.) coiled

Note: When hardware accessories (Machine Condition Detector [MCD] and cable) are connected to the SKF Microlog Inspector/ SKF MARLIN S-Pro IS CMDM 5360, CMDM 5460 or CMDM 5660, the complete **system** is not ATEX or IECEx certified and may only be used in non-hazardous areas.



Ordering information

- **CMAC 6109** Cable, SKF S-Pro (CMDM 5360 / CMDM 5460 / CMDM 5660 series) to MCD Pro IS.

CMAC 6115

Snap-on adapter, SKF S-Pro to CMAC 6109 cable

The CMAC 6115 snap-on adapter is used to connect the CMAC 6109 cable from the MCD Pro IS (CMVL 3600-IS) to the SKF S-Pro.

Specifications

- Connectors: Serial 15 pin female connector and AC input jack

Note: When hardware accessories (Machine Condition Detector [MCD] and cable) are connected to the SKF Microlog Inspector/ SKF MARLIN S-Pro IS CMDM 5360, CMDM 5460 or CMDM 5660, the complete **system** is not ATEX or IECEx certified and may only be used in non-hazardous areas.



Ordering information

- **CMAC 6115** Snap-on adapter, SKF S-Pro (CMDM 5360, CMDM 5460 or CMDM 5660 series) to CMAC 6109 cable.

S-Pro Models

- CMDM 5360
- CMDM 5460
- CMDM 5660
- CMDM 5700
- CMDM 5860

I-Pro Models

- CMDM 6200
- CMDM 6400
- CMDM 6500
- CMDM 6600
- CMDM 6700

S-Pro Models

- CMDM 5360
- CMDM 5460
- CMDM 5660
- CMDM 5700
- CMDM 5860

I-Pro Models

- CMDM 6200
- CMDM 6400
- CMDM 6500
- CMDM 6600
- CMDM 6700

CMAC 6141

Cable, SKF I-Pro to MCD Pro IS or VibPak

The CMAC 6141 cable is used to connect the CMDM 6500, CMDM 6600 or CMDM 6700 series SKF I-Pro to the MCD Pro IS (CMVL 3600-IS) or the VibPak (CMVL 3700).

Note: When using the CMDM 6500 or CMDM 6600 I-Pro device, this cable requires the CMAC 6142 snap-on adapter. When using the CMDM 6700 series I-Pro device, this cable requires the CMAC 6159 snap-on adapter.

Specifications

- Connectors: Serial nine pin female to mini-serial nine pin male
- Length: 76,2 cm (30 in.) coiled



Ordering information

- **CMAC 6141** Cable, SKF I-Pro (CMDM 6500, CMDM 6600 or CMDM 6700 series) to MCD Pro IS or VibPak.

S-Pro Models

CMDM 5360
CMDM 5460
CMDM 5660
CMDM 5700
CMDM 5860

I-Pro Models

CMDM 6200
CMDM 6400
● CMDM 6500
● CMDM 6600
● CMDM 6700

CMAC 6142

Snap-on adapter, SKF I-Pro to CMAC 6141 cable

The CMAC 6142 snap-on adapter is used to connect the CMAC 6141 cable from either the VibPak (CMVL 3700) or MCD Pro IS (CMVL 3600-IS) to the CMDM 6500 / CMDM 6600 series SKF I-Pro.

Specifications

- Connectors: Serial nine pin male

S-Pro Models

CMDM 5360
CMDM 5460
CMDM 5660
CMDM 5700
CMDM 5860

I-Pro Models

CMDM 6200
CMDM 6400
● CMDM 6500
● CMDM 6600
CMDM 6700



Ordering information

- **CMAC 6142** Snap-on adapter, SKF I-Pro (CMDM 6500 / CMDM 6600 series) to CMAC 6141 cable.

CMAC 6159

Snap-on adapter, SKF I-Pro CDM 6700 to CMAC 6141 cable

The CMAC 6159 snap-on adapter is used to connect the CMAC 6141 cable to the CDM 6700 series SKF I-Pro.

Specifications

- Connectors: RS 232 nine pin male and BNC three pin male



Ordering information

- **CMAC 6159** Snap-on adapter, SKF I-Pro (CMDM 6700) to CMAC 6141 cable.

S-Pro Models

CMDM 5360
CMDM 5460
CMDM 5660
CMDM 5700
CMDM 5860

I-Pro Models

- CMDM 6200
- CMDM 6400
- CMDM 6500
- CMDM 6600
- CMDM 6700

CMAC 6148

Cable, SKF I-Pro to infrared thermometer gun

The CMAC 6148 cable is used to connect the CDM 6500, CDM 6600 or CDM 6700 series SKF I-Pro to the wired infrared thermometer gun (CMAC 4200).

Note: When using the CDM 6500 or CDM 6600 I-Pro device, this cable requires the CMAC 6142 snap-on adapter. When using the CDM 6700 series I-Pro device, this cable requires the CMAC 6159 snap-on adapter.

Specifications

- Connectors: Input adapter to serial nine pin female
- Length: 76,2 cm (30 in.) coiled



Ordering information

- **CMAC 6148** Cable, SKF I-Pro (CMDM 6500, CMDM 6600 or CMDM 6700 series) to infrared thermometer gun.

S-Pro Models

CMDM 5360
CMDM 5460
CMDM 5660
CMDM 5700
CMDM 5860

I-Pro Models

- CMDM 6200
- CMDM 6400
- CMDM 6500
- CMDM 6600
- CMDM 6700

Batteries and power accessories



Compatibility	35
Battery, CMAC 6111.	36
Battery, CMAC 6117.	36
Battery, non-NI, CMAC 6134	37
Battery, CMAC 6164.	37
Battery, NI, CMAC 6155	38
Battery, CMAC 6177.	38
Battery, non-NI, CMAC 6143	39
Battery, NI, CMAC 6144	39
Docking station, CMAC 6110.	40
Multi-dock station, CMAC 6135	40
Quad Ethernet docking station, CMAC 6135-E.	41
Docking station, CMAC 6136.	41
Docking station, CMAC 6160.	42
Quad Ethernet docking station, CMAC 6166-E.	42
Docking station, CMAC 6169.	43
Quad charging station, CMAC 6172.	43
Ethernet adapter, CMAC 6156.	44
Ethernet adapter, CMAC 6173.	44

Two-bay charger, CMAC 6145	45
Universal power adapter, CMAC 6157	45
Universal power supply, CMAC 6147	46
Power supply, CMAC 8004	46
Charging station, CMAC 8001	47
Power cord, UL, 110, US, CMVL 3351	47

Compatibility

The following table shows which power accessories (batteries, docking stations, etc.) are compatible with the different models of the SKF Microlog Inspector and MARLIN systems. The pages that follow describe each of the power accessories listed below.

Power accessory		SKF Microlog Inspector and SKF MARLIN system models									
		CMDM 5360	CMDM 5460	CMDM 5660	CMDM 5760	CMDM 5860	CMDM 6200	CMDM 6400	CMDM 6500	CMDM 6600	CMDM 6700
model number	Power accessory description										
CMAC 6110	Docking station	●	●	●		●					
CMAC 6111	Battery						●	●			
CMAC 6117	Battery	●	●	●		●					
CMAC 6134	Battery, non-NI							●	●		
CMAC 6135	Multi-dock station							●	●		
CMAC 6135-E	Quad Ethernet docking station								●		
CMAC 6136	Docking station							●	●		
CMAC 6155	Battery, NI							●	●		
CMAC 6157	Universal power adapter	●	●	●	●	●	●	●	●	●	
CMAC 6160	Docking station									●	
CMAC 6164	Battery									●	
CMAC 6166-E	Quad Ethernet docking station									●	
CMAC 6169	Docking station				●						
CMAC 6172	Quad charging station				●						
CMAC 6173	Ethernet adapter				●						
CMAC 6177	Battery				●						
CMVL 3351	Power cord, UL, 110, US	●	●	●	●	●	●	●	●	●	

CMAC 6111

Battery

The CMAC 6111 battery is used for the CMDM 6200 and CMDM 6400 series SKF I-Pro devices only.

Specifications

- Type: Lithium-ion
- Maximum output: 7,2 V
- Capacity: 17,3 Wh

S-Pro Models

- CMDM 5360
- CMDM 5460
- CMDM 5660
- CMDM 5700
- CMDM 5860

I-Pro Models

- CMDM 6200
- CMDM 6400
- CMDM 6500
- CMDM 6600
- CMDM 6700



CMAC 6117

Battery

The CMAC 6117 battery is used for SKF S-Pro devices only.

Specifications

- Type: Lithium-ion
- Maximum output: 7,4 V
- Capacity: 2 200 mAh

S-Pro Models

- CMDM 5360
- CMDM 5460
- CMDM 5660
- CMDM 5700
- CMDM 5860

I-Pro Models

- CMDM 6200
- CMDM 6400
- CMDM 6500
- CMDM 6600
- CMDM 6700



Ordering information

- **CMAC 6111** Battery for SKF I-Pro CMDM 6200 and CMDM 6400 series only.

Ordering information

- **CMAC 6117** Battery for SKF S-Pro devices only.

CMAC 6134

Battery, non-Ni

The CMAC 6134 battery is used for the non-Ni CMDM 6510 and CMDM 6610 series I-Pro only.

Specifications

- Type: Lithium-ion
- Dimensions: 70 × 79 × 17 mm (2.8 × 3.1 × 0.7 in.)
- Weight: 113 g (4.0 oz.)
- Maximum output: 4,2 V
- Mean output: 3,7 V
- Capacity: 4 000 mAh (14,8 Wh)
- Operating temperature: -10 to +50 °C (15 to 125 °F)
- Charging temperature: 0 to 40 °C (30 to 105 °F)
- Storage temperature:
 - For up to one year: -20 to +35 °C (-5 to +95 °F)
 - Recommended: 25 °C (75 °F)
 - For 3 to 12 months: -20 to +25 °C (-5 to +80 °F)
- Relative humidity: 5 to 95% non-condensing
- Charge time, fully discharged: 6 hours

S-Pro Models

CMDM 5360
CMDM 5460
CMDM 5660
CMDM 5700
CMDM 5860

I-Pro Models

CMDM 6200
CMDM 6400
● CMDM 6500
● CMDM 6600
CMDM 6700

CMAC 6164

Battery

The CMAC 6164 battery is used for the CMDM 6700 series I-Pro only.

Specifications

- Type: Lithium-ion
- Dimensions: 77,3 × 60,7 × 17,0 mm (3.0 × 2.4 × 0.7 in.)
- Weight: 104 g (3.7 oz.)
- Maximum output: 4,2 V
- Nominal output: 3,7 V
- Capacity: 4 000 mAh (14,8 Wh)
- Operating temperature: -20 to +60 °C (-5 to +140 °F)
- Charging temperature: 0 to 45 °C (30 to 115 °F)
- Storage temperature:
 - For up to one year: -20 to +25 °C (-5 to +75 °F)
 - For up to one month: -20 to +60 °C (-5 to +140 °F)
- Relative humidity: 5 to 95% non-condensing
- Charge time, fully discharged: 6 hours

S-Pro Models

CMDM 5360
CMDM 5460
CMDM 5660
CMDM 5700
CMDM 5860

I-Pro Models

CMDM 6200
CMDM 6400
CMDM 6500
CMDM 6600
● CMDM 6700



Ordering information

- **CMAC 6134** Battery for non-Ni SKF I-Pro CMDM 6510 and CMDM 6610 series only.



Ordering information

- **CMAC 6164** Battery for SKF I-Pro CMDM 6700 series only.

CMAC 6155

Battery, NI

The CMAC 6155 battery is used for the NI CDM 6520, CDM 6521, CDM 6620 and CDM 6621 series I-Pro only.

Specifications

- Type: Lithium-ion
- Dimensions: 70 × 79 × 17 mm (2.8 × 3.1 × 0.7 in.)
- Weight: 113 g (4.0 oz.)
- Maximum output: 4,2 V
- Mean output: 3,7 V
- Capacity: 4 000 mAh (14,8 Wh)
- Operating temperature: -10 to +50 °C (15 to 120 °F)
- Charging temperature: 0 to 40 °C (30 to 105 °F)
- Storage temperature:
 - For up to one year: -20 to +35 °C (-5 to +95 °F)
 - Recommended: 25 °C (75 °F)
 - For 3 to 12 months: -20 to +25 °C (-5 to +75 °F)
- Relative humidity: 5 to 95% non-condensing
- Charge time, fully discharged: 6 hours



Ordering information

- **CMAC 6155** Battery for NI SKF I-Pro CDM 6520, CDM 6620, CDM 6521 and CDM 6621 series only.

CMAC 6177

Battery

The CMAC 6177 battery is used for the CDM 5700 series S-Pro only.

Specifications

- Type: Lithium-ion
- Mean output: 3,7 V
- Capacity: 4 000 mAh (14,8 Wh)



Ordering information

- **CMAC 6177** Battery for SKF S-Pro CDM 5700 series only.

S-Pro Models

- CMDM 5360
- CMDM 5460
- CMDM 5660
- CMDM 5700
- CMDM 5860

I-Pro Models

- CMDM 6200
- CMDM 6400
- CMDM 6500
- CMDM 6600
- CMDM 6700

S-Pro Models

- CMDM 5360
- CMDM 5460
- CMDM 5660
- CMDM 5700
- CMDM 5860

I-Pro Models

- CMDM 6200
- CMDM 6400
- CMDM 6500
- CMDM 6600
- CMDM 6700

CMAC 6143

Battery, non-NI

The CMAC 6143 battery is for use in non-NI handheld RFID readers CMRF 6510, CMRF 6530, CMRF 6710 and CMRF 6730 only.

Specifications

- Type: Lithium-ion
- Dimensions: 11,68 × 3,43 cm (4.60 × 1.35 in.)
- Weight: 96,39 g (3.4 oz.)
- Maximum output: 4,2 V
- Mean output: 3,7 V
- Capacity: 2 400 mAh (8,9 Wh)
- Operating temperature: -20 to +60 °C (-5 to +140 °F)
- Charging temperature for desktop / wall mount one-bay charger: 0 to 35 °C (30 to 95 °F)
- Charging temperature for two-bay, four-bay and eight-bay chargers: 0 to 45 °C (30 to 115 °F)
- Storage temperature: -20 to +60 °C (-5 to +140 °F), 20 °C (70 °F) recommended
- Relative humidity: 0 to 95% non-condensing
- Charge time, fully discharged: 3 to 4 hours



Ordering information

- **CMAC 6143** Battery for handheld RFID readers CMRF 6510, CMRF 6530, CMRF 6710 and CMRF 6730 only.

CMAC 6144

Battery, NI

The CMAC 6144 battery is for use in the handheld NI RFID reader CMRF 6520 and CMRF 6720 only.

Specifications

- Type: Lithium-ion
- Dimensions: 11,68 × 3,43 cm (4.60 × 1.35 in.)
- Weight: 96,39 g (3.4 oz.)
- Maximum output: 4,2 V
- Mean output: 3,7 V
- Capacity: 2 400 mAh (8,9 Wh)
- Operating temperature: -20 to +60 °C (-5 to +140 °F)
- Charging temperature for desktop / wall mount one-bay charger: 0 to 35 °C (30 to 95 °F)
- Charging temperature for two-bay, four-bay and eight-bay chargers: 0 to 45 °C (30 to 115 °F)
- Storage temperature: -20 to +60 °C (-5 to +140 °F), 20 °C (70 °F) recommended
- Relative humidity: 0 to 95% non-condensing
- Charge time, fully discharged: 3 to 4 hours



Ordering information

- **CMAC 6144** Battery for handheld NI RFID reader CMRF 6520 and CMRF 6720 only.

CMAC 6110

Docking station

The CMAC 6110 docking station, with AC adapter and power cable, is used to dock the SKF S-Pro device for charging and communication. The CMAC 6104 USB communication cable is also supplied with this docking station in order to connect the docking station to the PC.

S-Pro Models

- CMDM 5360
- CMDM 5460
- CMDM 5660
- CMDM 5700
- CMDM 5860

I-Pro Models

- CMDM 6200
- CMDM 6400
- CMDM 6500
- CMDM 6600
- CMDM 6700



Ordering information

- **CMAC 6110** Docking station for SKF MARLIN S-Pro models.

CMAC 6135

Multi-dock station

The CMAC 6135 docking station is used to dock up to four SKF I-Pro devices for charging only.

S-Pro Models

- CMDM 5360
- CMDM 5460
- CMDM 5660
- CMDM 5700
- CMDM 5860

I-Pro Models

- CMDM 6200
- CMDM 6400
- CMDM 6500
- CMDM 6600
- CMDM 6700



Ordering information

- **CMAC 6135** Multi-dock station for SKF I-Pro CMDM 6500 and CMDM 6600 series.

CMAC 6135-E

Quad Ethernet docking station

The CMAC 6135-E quad Ethernet docking station with power supply is used for docking and charging up to four CMDM 6600 series SKF I-Pro devices and for host and client connectivity.

The CMAC 6135-E includes two RJ45 Ethernet ports for upstream connections and downstream "daisy-chain" connections of up to 10 docks.

The CMAC 6135-E typically charges the I-Pro devices in less than four hours (up to six hours for fully discharged batteries).

Note: CMAC 6135-E includes US power cord and power supply.



S-Pro Models

- CMDM 5360
- CMDM 5460
- CMDM 5660
- CMDM 5700
- CMDM 5860

I-Pro Models

- CMDM 6200
- CMDM 6400
- CMDM 6500
- CMDM 6600
- CMDM 6700

CMAC 6136

Docking station

The CMAC 6136 docking station with power adapter is used to dock the CMDM 6500 and CMDM 6600 series SKF I-Pro device for charging and communication.

Note: CMAC 6136 includes US power cord.

S-Pro Models

- CMDM 5360
- CMDM 5460
- CMDM 5660
- CMDM 5700
- CMDM 5860

I-Pro Models

- CMDM 6200
- CMDM 6400
- CMDM 6500
- CMDM 6600
- CMDM 6700



Ordering information

- **CMAC 6135-E** Quad Ethernet docking station for SKF I-Pro CMDM 6600 series.

Ordering information

- **CMAC 6136** Docking station for SKF I-Pro CMDM 6500 and CMDM 6600 series.

CMAC 6160

Docking station

The CMAC 6160 desktop docking station with power supply is used for docking and charging the CMDM 6700 series SKF I-Pro device and for USB host and client connectivity.

The CMAC 6160 includes one mobile computer cup and one auxiliary pack charge cup and is capable of supporting two battery packs.

Note: CMAC 6160 includes US power cord and CMAC 6157 universal power adapter.

S-Pro Models

- CMDM 5360
- CMDM 5460
- CMDM 5660
- CMDM 5700
- CMDM 5860

I-Pro Models

- CMDM 6200
- CMDM 6400
- CMDM 6500
- CMDM 6600
- CMDM 6700



CMAC 6166-E

Quad Ethernet docking station

The CMAC 6166-E quad Ethernet docking station with power supply is used for docking and charging up to four CMDM 6700 series SKF I-Pro devices and for host and client connectivity.

The CMAC 6166-E includes two RJ45 Ethernet ports for upstream connections and downstream "daisy-chain" connections of up to 10 docks.

The CMAC 6166-E typically charges the I-Pro devices in less than four hours (up to six hours for fully discharged batteries).

Note: CMAC 6166-E includes US power cord and power supply.

S-Pro Models

- CMDM 5360
- CMDM 5460
- CMDM 5660
- CMDM 5700
- CMDM 5860

I-Pro Models

- CMDM 6200
- CMDM 6400
- CMDM 6500
- CMDM 6600
- CMDM 6700



Ordering information

- **CMAC 6160** Docking station for SKF I-Pro CMDM 6700 series.

Ordering information

- **CMAC 6166-E** Quad Ethernet docking station for SKF I-Pro CMDM 6700 series.

CMAC 6169

Docking station

The CMAC 6169 docking station with power adapter is used to dock the CMDM 5700 series SKF S-Pro device for charging and communication.

Note: CMAC 6169 includes US power cord.

S-Pro Models

- CMDM 5360
- CMDM 5460
- CMDM 5660
- CMDM 5700
- CMDM 5860

I-Pro Models

- CMDM 6200
- CMDM 6400
- CMDM 6500
- CMDM 6600
- CMDM 6700



CMAC 6172

Quad charging station

The CMAC 6172 charging station with power adapter is used to dock up to four CMDM 5700 series SKF S-Pro devices for charging only.

S-Pro Models

- CMDM 5360
- CMDM 5460
- CMDM 5660
- CMDM 5700
- CMDM 5860

I-Pro Models

- CMDM 6200
- CMDM 6400
- CMDM 6500
- CMDM 6600
- CMDM 6700



Ordering information

- **CMAC 6169** Docking station for SKF S-Pro CMDM 5700 series.

Ordering information

- **CMAC 6172** Quad charging station for SKF S-Pro CMDM 5700 series.

CMAC 6156

Ethernet adapter

The CMAC 6156 adapter is used to connect an Ethernet cable directly to the CMAC 6136 or CMAC 6160 docking station (used with the CMDM 6700, CMDM 6610 or CMDM 6620 I-Pro devices). The adapter connects to the side of the docking station via the built-in USB connector.



S-Pro Models

CMDM 5360
 CMDM 5460
 CMDM 5660
 CMDM 5700
 CMDM 5860

I-Pro Models

CMDM 6200
 CMDM 6400
 CMDM 6500
 ● CMDM 6600
 ● CMDM 6700

CMAC 6173

Ethernet adapter

The CMAC 6173 adapter is used to connect an Ethernet cable directly to the CMAC 6169 docking station (used with the CMDM 5700 S-Pro device). The adapter connects to the back of the docking station via the built-in USB mini-A connector.

CMAC 6173 includes the Ethernet adapter, universal power supply, USB connector cable and 12 V power adapter cable.

* Requires special drivers that are include on the SKF Microlog Inspector product CD or available on www.skf.com/cm/updates.

S-Pro Models

CMDM 5360
 CMDM 5460
 CMDM 5660
 ● CMDM 5700
 CMDM 5860

I-Pro Models

CMDM 6200
 CMDM 6400
 CMDM 6500
 CMDM 6600
 CMDM 6700



Ordering information

- **CMAC 6156** Ethernet adapter.

Ordering information

- **CMAC 6173** Ethernet adapter with power supply and USB cable for CMAC 6169 docking station.

CMAC 6145

Two-bay charger

The CMAC 6145 two-bay charger is used to charge the batteries of the CMRF 6500 / CMRF 6700 series of handheld RFID readers. This charger can charge two RFID batteries simultaneously.



Ordering information

- **CMAC 6145** Two-bay charger for batteries for the CMRF 6500 / CMRF 6700 series handheld RFID reader.

CMAC 6157

Universal power adapter

The CMAC 6157 universal power adapter is used to connect the plug of a power cord to an international plug socket. With three individual plug adapters and adjustable blade, it adapts the following types of plugs: US, Japan, Australia, China, United Kingdom and European.

The CMAC 6157 universal power adapter is included with the SKF Microlog Inspector I-Pro kits with international radio codes and SKF Microlog Inspector S-Pro CDM 5660 kits, as well as the CMAC 6160 docking station.

Specifications

- Weight: 95 g (3.2 oz.)
- Dimensions: 60 × 53 × 43 mm (2.4 × 2.1 × 1.7 in.)
- Operating voltage: 110 to 250 VAC, 10 A
- Insulation resistance: ≥ 5 mΩ
- Voltage strength test: 2 000 V AC for one minute
- Accepts non-grounded or grounded plug-in format
- CE certified



Ordering information

- **CMAC 6157** Universal power adapter.

S-Pro Models

- CDM 5360
- CDM 5460
- CDM 5660
- CDM 5700
- CDM 5860

I-Pro Models

- CDM 6200
- CDM 6400
- CDM 6500
- CDM 6600
- CDM 6700

CMAC 6147

Universal power supply

The CMAC 6147 universal power supply is used to supply power to the CMRF 6500 / CMRF 6700 series of handheld RFID readers.

Note: The CMAC 6147 universal power supply requires the CMVL 3351 for North America or other country specific power cord.



CMAC 8004

Power supply

The CMAC 8004 international DC power supply is for use with the CMAC 8001 charging station (which is used with the CMVL 8000 WMCD). The CMAC 8004 also contains four international adapter plugs:

- US
- United Kingdom
- European
- Australian



Ordering information

- **CMAC 6147** Universal power supply for the CMRF 6500 / CMRF 6700 series of handheld RFID readers.

Ordering information

- **CMAC 8004** Power supply for use with the CMAC 8001 charging station.

CMAC 8001

Charging station

The CMAC 8001 charging station (with the CMAC 8004 international DC power supply) is used to charge the CMVL 8000 Wireless Machine Condition Detector (WMCD). The interchangeable plugs adapt for the following socket types:

- US
- United Kingdom
- European
- Australian



Ordering information

- **CMAC 8001** Charging station for CMVL 8000 WMCD.

CMVL 3351

Power cord, UL, 110, US

The CMVL 3351 power cord is used to connect a power supply to the SKF Microlog Inspector and SKF MARLIN devices and for the CMRF 6500 / CMRF 6700 series of handheld RFID readers.

Additional power cords that are available include:

- CMAC 4222-AU (Australian)
- CMAC 4222-EUR (European)
- CMAC 4222-UK (United Kingdom)



S-Pro Models

- CMDM 5360
- CMDM 5460
- CMDM 5660
- CMDM 5700
- CMDM 5860

I-Pro Models

- CMDM 6200
- CMDM 6400
- CMDM 6500
- CMDM 6600
- CMDM 6700

Ordering information

- **CMVL 3351** Power cord.

Miscellaneous accessories



Temperature magnet probe tip, CMAC 3610	51
Magnetic probe tip, CMAC 3611	51
Probe tip replacement kit, CMAC 3630	52
Medium duty magnetic base, CMSS 908-MD	52
Stylus with tether, CMAC 6105	53
Stylus with tether, CMAC 6138	53
Stylus with tether, CMAC 6162	54
Stylus with tether, CMAC 6170	54
Screen protector, CMAC 6114	55
Screen protector, CMAC 6139	55
Screen protector, CMAC 6174	56
Holster, CMAC 6140	56
Leather holster, CMAC 6153	57
Leather case, CMAC 6152	57
Leather carrying case, CMAC 6175	58
Connection cover, CMAC 6154	58
Connection cover, CMAC 6161	59
Nylon belt holster	59
Belt clip, CMAC 8003	60

Micro Secure Digital (SD) memory card, CMAC 6137	60
Micro Secure Digital (SD) memory card, CMAC 6165	61
Micro Secure Digital (SD) memory card, CMAC 6176	61
Stinger probe, CMSS 60139 series	62
Toolkits, CMAC 9600 series.	62
Hand strap, CMAC 6158	63
Hand strap, CMAC 6171	63
General purpose, low profile, side exit industrial accelerometer for use with VibPak, CMSS 2200	64
Leak tags for compressed air systems, CMAC 8600-LEAK TAG-50.	65
SKF barcode tags, CMAC 6178 / CMAC 6179	65
Large, rugged RFID tag, CMAC 6181	66
Low profile, rugged RFID tag, CMAC 6182 / CMAC 6183	66

CMAC 3610

Temperature magnet probe tip

The CMAC 3610 temperature magnet is used with the CMVL 8000 WMCD and the CMVL 3600-IS MCD Pro IS.

Specifications

- Temperature range: 0 to 100 °C (30 to 210 °F)
- Tolerance: $\pm 2^\circ$ (on clean, flat, smooth surface)



Ordering information

- **CMAC 3610** Temperature magnet probe tip.

CMAC 3611

Magnetic probe tip

The CMAC 3611 magnetic probe tip is used with the CMVL 3600-IS MCD Pro IS.

Specifications

- 38,1 mm (1.50 in.) diameter
- 34,9 mm (1.38 in.) height



Ordering information

- **CMAC 3611** Magnetic probe tip.

CMAC 3630

Probe tip replacement kit

The CMAC 3630 is a probe tip replacement kit for the temperature magnet probe tip (CMAC 3610). The kit contains a probe tip and an 18 mm shop cone wrench.



Ordering information

- CMAC 3630 Probe tip replacement kit.

CMSS 908-MD

Medium duty magnetic base

The CMSS 908-MD is a multi-purpose magnetic base designed for industrial vibration monitoring applications. The low profile magnet has a 1/4-28 mounting hole to allow compatibility with SKF accelerometers and provides a solid mechanical connection to the machine. This magnetic base is used with the CMVL 3700 VibPak.

Specifications

- Diameter: 35 mm (1.40 in.)
- Height: 19 mm (0.75 in.)
- Pull strength: 23 kg (50 lbs.)
- Mounting hole: 1/4-28



Ordering information

- CMSS 908-MD Medium duty magnetic base.

CMAC 6105

Stylus with tether

The CMAC 6105 stylus is used with the CMDM 6200 and CMDM 6400 series SKF I-Pro devices. The stylus is supplied with a tether to connect to the device.

S-Pro Models

CMDM 5360
CMDM 5460
CMDM 5660
CMDM 5700
CMDM 5860

I-Pro Models

● CMDM 6200
● CMDM 6400
CMDM 6500
CMDM 6600
CMDM 6700



Ordering information

- **CMAC 6105** Stylus with tether (package of five).

CMAC 6138

Stylus with tether

The CMAC 6138 stylus is used with the CMDM 6500 and CMDM 6600 SKF I-Pro devices. The stylus is supplied with a tether to connect to the device.

S-Pro Models

CMDM 5360
CMDM 5460
CMDM 5660
CMDM 5700
CMDM 5860

I-Pro Models

CMDM 6200
CMDM 6400
● CMDM 6500
● CMDM 6600
CMDM 6700



Ordering information

- **CMAC 6138** Stylus with tether (package of five).

CMAC 6162

Stylus with tether

The CMAC 6162 stylus is used with the CMDM 6700 SKF I-Pro devices. The stylus is supplied with a tether to connect to the device.

S-Pro Models

CMDM 5360
CMDM 5460
CMDM 5660
CMDM 5700
CMDM 5860

I-Pro Models

CMDM 6200
CMDM 6400
CMDM 6500
CMDM 6600
● CMDM 6700



Ordering information

- **CMAC 6162** Stylus with tether (package of five).

CMAC 6170

Stylus with tether

The CMAC 6170 stylus is used with the CMDM 5700 SKF S-Pro devices. The stylus is supplied with a tether to connect to the device.

S-Pro Models

CMDM 5360
CMDM 5460
CMDM 5660
● CMDM 5700
CMDM 5860

I-Pro Models

CMDM 6200
CMDM 6400
CMDM 6500
CMDM 6600
CMDM 6700



Ordering information

- **CMAC 6170** Stylus with tether.

CMAC 6114

Screen protector

The CMAC 6114 screen protector helps keep the LCD plastic cover of the CMDM 6200 and CMDM 6400 SKF I-Pro device from scratching. CMAC 6114 includes a set of 25 self-adhesive screen protectors.



S-Pro Models

CMDM 5360
CMDM 5460
CMDM 5660
CMDM 5700
CMDM 5860

I-Pro Models

- CMDM 6200
- CMDM 6400
- CMDM 6500
- CMDM 6600
- CMDM 6700

CMAC 6139

Screen protector

The CMAC 6139 screen protector helps keep the LCD plastic cover of the CMDM 6500, CMDM 6600 and CMDM 6700 SKF I-Pro device from scratching. CMAC 6139 includes a set of five self-adhesive screen protectors.



S-Pro Models

CMDM 5360
CMDM 5460
CMDM 5660
CMDM 5700
CMDM 5860

I-Pro Models

- CMDM 6200
- CMDM 6400
- CMDM 6500
- CMDM 6600
- CMDM 6700

Ordering information

- **CMAC 6114** Screen protector (package of 25).

Ordering information

- **CMAC 6139** Screen protector (package of five).

CMAC 6174

Screen protector

The CMAC 6174 screen protector helps keep the LCD plastic cover of the CMDM 5700 SKF S-Pro device from scratching. CMAC 6174 includes a set of 10 self-adhesive screen protectors.

S-Pro Models

- CMDM 5360
- CMDM 5460
- CMDM 5660
- CMDM 5700
- CMDM 5860

I-Pro Models

- CMDM 6200
- CMDM 6400
- CMDM 6500
- CMDM 6600
- CMDM 6700



CMAC 6140

Holster

The CMAC 6140 holster is designed to provide protection to the SKF I-Pro when not in use. The holster contains a belt loop with snaps that allows the holster to hang from a belt. The holster also has three pockets, one for the device and two smaller side pockets to keep smaller accessories.

S-Pro Models

- CMDM 5360
- CMDM 5460
- CMDM 5660
- CMDM 5700
- CMDM 5860

I-Pro Models

- CMDM 6200
- CMDM 6400
- CMDM 6500
- CMDM 6600
- CMDM 6700



Ordering information

- **CMAC 6174** Screen protector (package of 10).

Ordering information

- **CMAC 6140** Holster.

CMAC 6153

Leather holster

The CMAC 6153 leather holster is used to provide protection to the SKF S-Pro device. The holster includes an elastic band that snaps to each side to cover the top of the device.

S-Pro Models

- CDM 5360
- CDM 5460
- CDM 5660
- CDM 5700
- CDM 5860

I-Pro Models

- CDM 6200
- CDM 6400
- CDM 6500
- CDM 6600
- CDM 6700



Ordering information

- CMAC 6153 Leather holster.

CMAC 6152

Leather case

The CMAC 6152 leather case is used to provide protection to the CMAC 4230 wireless infrared thermometer gun.



Ordering information

- CMAC 6152 Leather case.

CMAC 6175

Leather carrying case

The CMAC 6175 leather carrying case is used to provide protection to the CDM 5700 series SKF S-Pro device. The carrying case has a cover that can snap into two different positions and an adjustable hand strap. It also includes a tethered stylus and adjustable shoulder strap.



Ordering information

- **CMAC 6175** Leather carrying case with tethered stylus and shoulder strap.

CMAC 6154

Connection cover

The CMAC 6154 connection cover attaches to the bottom of the CDM 6500 and CDM 6600 series SKF I-Pro device to protect the docking station connectors in harsh environments.



Ordering information

- **CMAC 6154** Connection cover.

S-Pro Models

- CMDM 5360
- CMDM 5460
- CMDM 5660
- CMDM 5700
- CMDM 5860

I-Pro Models

- CMDM 6200
- CMDM 6400
- CMDM 6500
- CMDM 6600
- CMDM 6700

S-Pro Models

- CMDM 5360
- CMDM 5460
- CMDM 5660
- CMDM 5700
- CMDM 5860

I-Pro Models

- CMDM 6200
- CMDM 6400
- CMDM 6500
- CMDM 6600
- CMDM 6700

CMAC 6161

Connection cover

The CMAC 6161 connection cover attaches to the bottom of the CMDM 6700 series SKF I-Pro device to protect the docking station connectors in harsh environments.



S-Pro Models

CMDM 5360
CMDM 5460
CMDM 5660
CMDM 5700
CMDM 5860

I-Pro Models

CMDM 6200
CMDM 6400
CMDM 6500
CMDM 6600
● CMDM 6700

31784200

Nylon belt holster

This nylon belt holster is used with the CMAC 4200 infrared thermometer gun. It provides protection to the thermometer gun when not in use and contains a loop on the back that allows the holster to hang from a belt for easy carrying.



Ordering information

- **CMAC 6161** Connection cover.

Ordering information

- **31784200** Nylon belt holster.

CMAC 8003

Belt clip

The CMAC 8003 belt clip is used with the CMVL 8000 Wireless Machine Condition Detector (WMCD). The belt clip attaches to the WMCD so that it can be carried around safely until needed.



Ordering information

- **CMAC 8003** Belt clip.

CMAC 6137

Micro Secure Digital (SD) memory card

The CMAC 6137 micro SD memory card (2 GB) is available for use in the CDM 6500 and CDM 6600 SKF I-Pro devices.



Ordering information

- **CMAC 6137** Micro Secure Digital (SD) memory card, 2 GB.

S-Pro Models

CMDM 5360
CMDM 5460
CMDM 5660
CMDM 5700
CMDM 5860

I-Pro Models

CMDM 6200
CMDM 6400
● CMDM 6500
● CMDM 6600
CMDM 6700

CMAC 6165

Micro Secure Digital (SD) memory card

The CMAC 6165 micro SD memory card (4 GB) is available for use in the CMDM 6700 series SKF I-Pro devices.



S-Pro Models

CMDM 5360
CMDM 5460
CMDM 5660
CMDM 5700
CMDM 5860

I-Pro Models

CMDM 6200
CMDM 6400
CMDM 6500
CMDM 6600
● CMDM 6700

CMAC 6176

Micro Secure Digital (SD) memory card

The CMAC 6176 industrial grade micro SD memory card (2 GB) is available for use in the CMDM 5700 series SKF S-Pro devices. The memory card is water-proof, dust-proof, shock-proof and ESD (electrostatic discharge) proof.



S-Pro Models

CMDM 5360
CMDM 5460
CMDM 5660
● CMDM 5700
CMDM 5860

I-Pro Models

CMDM 6200
CMDM 6400
CMDM 6500
CMDM 6600
CMDM 6700

Ordering information

- **CMAC 6165** Micro Secure Digital (SD) memory card, 4 GB.

Ordering information

- **CMAC 6176** Micro Secure Digital (SD) memory card, 2 GB.

CMSS 60139 series

Stinger probe

The CMSS 60139 series “stinger” probe is used with the CMVL 3600-IS MCD Pro IS. The probe is available in three lengths:

- 10,2 cm (4 in.)
- 15,2 cm (6 in.)
- 30,5 cm (12 in.)



Ordering information

- **CMSS 60139-04** Stinger probe, 10,2 cm (4 in.).
- **CMSS 60139-06** Stinger probe, 15,2 cm (6 in.).
- **CMSS 60139-12** Stinger probe, 30,5 cm (12 in.).

CMAC 9600 series

Toolkits

The CMAC 9600 series of toolkits contain the necessary tools when working with the SKF MARLIN QuickConnect (MQC) studs. The toolkits are available in 1/4-28 or M8 × 1,25 versions. Each toolkit contains a drill bit, tap and pilot, or each tool can be purchased separately.



Ordering information

- **CMAC 9600-01:** Toolkit for spot face 1/4-28
- **CMAC 9600-02:** Toolkit for spot face M8 × 1,25
- **CMAC 9600-03:** Drill bit for 1/4-28 kit
- **CMAC 9600-04:** Tap for 1/4-28 kit
- **CMAC 9600-05:** Pilot for 1/4-28 kit
- **CMAC 9600-06:** Drill bit for M8 × 1,25 kit
- **CMAC 9600-07:** Tap for M8 × 1,25 kit
- **CMAC 9600-08:** Pilot for M8 × 1,25 kit
- **CMAC 9600-09:** End mill or counter bore for either kit
- **CMAC 9600-10:** Toolkit for spot face M6 × 1,25

CMAC 6158

Hand strap

The CMAC 6158 replacement hand strap attaches to the CMDM 6500 and CMDM 6600 series SKF I-Pro devices to help hold and carry the device. Five hand straps are included in each order.

S-Pro Models

CMDM 5360
CMDM 5460
CMDM 5660
CMDM 5700
CMDM 5860

I-Pro Models

CMDM 6200
CMDM 6400
● CMDM 6500
● CMDM 6600
CMDM 6700



Ordering information

- **CMAC 6158** Hand strap (package of five).

CMAC 6171

Hand strap

The CMAC 6171 replacement hand strap attaches to the CMDM 5700 series SKF S-Pro devices to help hold and carry the device.

S-Pro Models

CMDM 5360
CMDM 5460
CMDM 5660
● CMDM 5700
CMDM 5860

I-Pro Models

CMDM 6200
CMDM 6400
CMDM 6500
CMDM 6600
CMDM 6700



Ordering information

- **CMAC 6171** Hand strap.

CMSS 2200

General purpose, low profile, side exit industrial accelerometer for use with VibPak

This 100 mV/g industrial accelerometer, with its side exit and two pin connector, offers a low profile for machinery with limited clearance. The sensor mounts in any orientation. This rugged, economical and all around general purpose sensor is compatible with the CMVL 3700 VibPak.

Use this accelerometer with the VibPak to collect vibration velocity and enveloped acceleration data from machinery in remote or hard-to-reach locations. The collected data can then be trended with the SKF Microlog Inspector application.

Features

- Rugged, economical and all around general purpose sensor
- 100 mV/g sensitivity to optimize use in multiple applications
- Exceptional bias voltage (BV) stability at elevated temperatures
- Designed for exceptional low noise level for low frequencies at elevated temperatures
- Meets stringent CE, EMC requirements
- Low profile with captive mounting bolts (1/4–28, M6 × 1,00 or M8 × 1,25) provided
- Corrosion resistant and hermetically sealed
- Reverse polarity wiring protection

Specifications

Dynamic

- Sensitivity: 100 mV/g
- Sensitivity precision: ±10% at 25 °C (75 °F)
- Acceleration range: 80 g peak
- Amplitude linearity: 1%
- Frequency range:
 - ±10%: 1,0 to 5 000 Hz
 - ±3 dB: 0,7 to 10 000 Hz
- Resonance frequency, mounted, minimum: 22 kHz
- Transverse sensitivity: ≤ 5% of axial

Environmental

- Temperature range: –50 to +120 °C (–60 to +250 °F), operating temperature
- Vibration limit: 500 g peak
- Shock limit: 5 000 g peak
- Electromagnetic sensitivity, equivalent g, maximum: 70 µg/gauss
- Sealing: Hermetic
- Base strain sensitivity: 200 µg/µstrain
- CE: According to the generic immunity standard for Industrial Environment EN50082-2
 - Acceptance criteria: The generated “false equivalent g level” under the above test conditions should be less than 2 mg peak to peak



Electrical

- Power requirements:
 - Voltage source: 18 to 30 V DC
 - Constant current diode: 2 to 10 mA, recommended 4 mA
- Electrical noise: 2,0 Hz; 20 µg/√Hz
- Output impedance: < 100 Ω
- Bias output voltage: 12 V DC
- Grounding: Case isolated, internally shielded

Physical

- Dimensions: 53 × 25 × 40 mm (2.1 × 1.0 × 1.6 in.)
- Weight: 145 g (5.1 oz.)
- Case material: 316L stainless steel
- Mounting: See ordering information
- Mounting torque: 3,4 Nm (30 in. lbs.)
- Pin A connector: Signal/Power
- Pin B connector: Common
- Mating connector: CMSS 3106F-10SL-4S or equivalent
- Recommended cable: Two conductor shielded, fluorine based polymer jacket, 100 pF/m (30 pF/ft.) – CMAC 5209, CMAC 5209-06S or CMAC 5209-10
- Recommended magnetic base: CMSS 908-MD

Note: Specifications conform to ISA-RP-37.2 (1 to 64) and are typical values referenced at 25 °C (75 °F), 24 V DC supply, 4 mA constant current and 100 Hz.

Note: This accelerometer is not recommended for use in hazardous environments.

Ordering information

- **CMSS 2200** General purpose, low profile, side exit industrial accelerometer for use with VibPak, with MIL-C-5015 two pin connector. 1/4–28 and M6 mounting studs provided. Calibration sensitivity and nominal sensitivity are provided for each accelerometer package.
- **CMSS 2200-M8** General purpose, low profile, side exit industrial accelerometer for use with VibPak, with MIL-C-5015 two pin connector. M8 mounting studs provided. Calibration sensitivity and nominal sensitivity are provided for each accelerometer package.

CMAC 8600-LEAK TAG-50

Leak tags for compressed air systems

The CMAC 8600-LEAK TAG-50 is used for labeling leaks when identified during air system leak inspections. The leak tags, which measure 8,9 × 20,3 cm (3.5 × 8 in.), feature necessary information about the equipment and the leak. The top half of the perforated tag stays close to the leak and the bottom half is used for tracking the repair.

Additionally, a package of these tags is included in the CMAK 450-ML energy monitoring kit for compressed air systems and is also available as a separate purchase for customers who have a CMIN 400-K SKF Inspector 400 ultrasonic probe.

SKF Reliability Systems 5271 Viewridge Court San Diego, CA 92123 USA Telephone: +1 858-696-3400 Web site: www.skf.com/cm		
<h1>LEAK TAG</h1>		
Tag number:	Inspection date:	
Equipment ID:		
Location:	Identified by:	
	Gas type:	
	Pressure:	
Leak size (dB) / Sensitivity:		
Leak cost (\$):	<input type="checkbox"/> Small <input type="checkbox"/> Medium <input type="checkbox"/> Large <input type="checkbox"/> Extra Large	

Tag number:	Inspection date:	
Equipment ID:		
Location:	Identified by:	
	Gas type:	
	Pressure:	
Leak size (dB) / Sensitivity:		
Leak cost (\$):	<input type="checkbox"/> Small <input type="checkbox"/> Medium <input type="checkbox"/> Large <input type="checkbox"/> Extra Large	
Repaired by:	Repair date:	
Part number 32214300 • Revision A • November 2010		

Ordering information

- **CMAC 8600-LEAK TAG-50** Leak tags for compressed air systems (package of 50).

CMAC 6178 / CMAC 6179

SKF barcode tags

The barcode tags are used for labeling equipment that is monitored by SKF devices. The tags, which measure 3,2 × 5,1 cm (1.25 × 2 in.), are available in two different materials: anodized aluminum or plastic. The tags are sold in bundles of 200 with preset numbers (1 to 200 and 201 to 400).

The aluminum barcode tags (CMAC 6178) are printed directly on the metal plate and are incredibly durable. Its adhesive sticks to most every surface, including both plastics and metal assets.

The plastic barcode tags (CMAC 6179), while not as durable as the aluminum tags, are protected with a matte polyester top layer and are resistant from weather, chemicals and abrasion. The plastic barcode tags use an acrylic adhesive that bonds to metal and most plastic surfaces.



Ordering information

- **CMAC 6178-1/200** Aluminum SKF barcode tags with preset numbers 1 to 200 (package of 200).
- **CMAC 6178-201/400** Aluminum SKF barcode tags with preset numbers 201 to 400 (package of 200).
- **CMAC 6179-1/200** Plastic SKF barcode tags with preset numbers 1 to 200 (package of 200).
- **CMAC 6179-201/400** Plastic SKF barcode tags with preset numbers 201 to 400 (package of 200).

CMAC 6181

Large, rugged RFID tag

The CMAC 6181 reusable RFID tag is compatible with the CMDM 6700 SKF Microlog Inspector with integrated RFID reader and the CMRF 6500 / CMRF 6700 series of RFID readers. The CMAC 6181 RFID tag is designed to provide both edge and normal reading performance.

With a long range global performance, it is suitable for harsh environments and meets global standards. This passive tag meets Gen 2 / 18000-6C requirements. Typical applications include automotive containers, large metal containers, postal roll cages, metal drums, etc. The CMAC 6181 can be attached using screws, rivets, double-sided adhesive strips or a variety of other methods.

Specifications

- Dimensions:
 - Length × Width: 94,5 × 72,4 mm (3.72 × 2.85 in.)
 - Thickness: 9,9 mm (0.39 in.)
- Memory size: 512 bit user memory
- Data retention: EEPROM 2 years minimum (10 000 cycles)
- Temperature range:
 - Storage: –40 to +85 °C (–40 to +185 °F)
 - Operating: –40 to +65 °C (–40 to +150 °F)
- Vibration: 5 g RMS, 1,6 to 2 000 Hz flat spectrum
- IP rating: IP67
- Frequency: 860 to 960 MHz
- Typical read range:
 - Front: 6 m (20 ft.)
 - Lateral: 4 m (13 ft.)
- Compliance: RoHS and WEE



Ordering information

- **CMAC 6181-10** Large, rugged, global radio RFID tag (package of 10 tags).
- **CMAC 6181-250** Large, rugged, global radio RFID tag (package of 250 tags).

CMAC 6182 / CMAC 6183

Low profile, rugged RFID tag

The CMAC 6182 and CMAC 6183 reusable RFID tags are compatible with the CMDM 6700 SKF Microlog Inspector with integrated RFID reader and the CMRF 6500 / CMRF 6700 series of RFID readers. The tags are designed to provide superior performance on a variety of surfaces.

Suitable for harsh environments, these passive tags meet Gen 2 / 18000-6C requirements. Utilizing the latest generation of Gen 2 silicon within a small, durable form factor, these tags are suitable for tracking a wide variety of assets. These tags are optimized for metal surfaces such as metal containers, cages, and pallets, conveyance assets (containers and trailers), unit load devices, and other metal assets. The durable tags can be attached using screws, rivets, double-sided adhesive strips or a variety of other methods.

CMAC 6182 is tuned for FCC regions, while CMAC 6183 is tuned for ETSI regions (Europe).

Specifications

- Dimensions:
 - Length × Width: 111,5 × 21,8 mm (4.39 × 0.86 in.)
 - Thickness: 5,1 mm (0.20 in.)
- Memory size: 512 bit user memory
- Data retention: EEPROM 2 years minimum (10 000 cycles)
- Temperature range:
 - Storage: –40 to +93 °C (–40 to +200 °F)
 - Operating: –40 to +82 °C (–40 to +180 °F)
- Vibration: 5 g RMS, 1,5 to 2 000 Hz flat spectrum
- IP rating: IP67
- Frequency:
 - CMAC 6182: 902 to 928 MHz
 - CMAC 6183: 865 to 868 MHz
- Typical read range:
 - CMAC 6182: 4 m (13 ft.)
 - CMAC 6183: 5 m (16 ft.)



Ordering information

- **CMAC 6182-10** Low profile, rugged, FCC radio RFID tag (package of 10 tags).
- **CMAC 6182-250** Low profile, rugged, FCC radio RFID tag (package of 250 tags).
- **CMAC 6183-10** Low profile, rugged, ETSI radio RFID tag (package of 10 tags).
- **CMAC 6183-250** Low profile, rugged, ETSI radio RFID tag (package of 250 tags).

SKF Microlog Inspector systems

Easy-to-use technology designed to increase productivity, safety and efficiency

Automated inspections for data accuracy

The SKF Microlog Inspector application is the latest, most advanced system developed by SKF for recording inspection data. Previously, the SKF MARLIN system was used by operators as a replacement for verbal or paper inspection trails to document their observations with accurate, consistent and actionable information. This technology prompted corrective action when observed conditions deviated from established parameters, often preventing a more serious problem.

SKF Microlog Inspector takes the inspection process a step further

By becoming a truly independent application, which can be installed on many Windows Mobile portable computers, the SKF Microlog Inspector brings unmatched flexibility that allows customers to respond to their changing business needs. Customers can install the SKF Microlog Inspector application on multiple devices used throughout their organization and download specific inspection rounds directly to the operator. If a portable computer is broken, a spare can easily be deployed. No longer dependent on just USB transfer, a key advantage of SKF Microlog Inspector is the ability to transfer data over LAN or WiFi.

Key features

- Hardware independence across most current Windows Mobile portable devices
- Intuitive interface prompts for corrective actions when alarm levels are met
- Simplified user interface; screens and workflow designed by customers who use the product every day
- Inspection data documented for compliance reporting and audits
- Configurable screen size fonts
- Standardized notes can be used to document machinery and process conditions
- Capable of collecting velocity, acceleration, temperature and FFT data with a wireless sensor
- Dynamic filter view displays only points that need to be collected
- Barcode imager:
 - I-Pro system: Supports omnidirectional 1D, 2D, composite and postal decode capabilities plus signature capture
 - S-Pro system: SE 950:1D-Standard Range Scan Engine; reading range: 10 cm to 12 m (4 in. to 39 ft.)
- Integrated RFID reader (CMDM 6700 series)

Flexible technology to meet every inspection need

This powerful inspection system is ideally suited for operational efficiency, process and quality inspections, environmental, safety and regulatory compliance inspections, as well as predictive and preventive maintenance inspections, asset basic care and total productive maintenance inspection. When used with the Wireless Machine Condition Detector (WMCD), a portable Bluetooth enabled sensor, acceleration, velocity, temperature and FFT data can be collected. The vibration data that is collected will enable problem detection at low, mid and high frequency ranges. Routine collection of vibration data during inspection rounds makes critical machine data available on a regular basis, eliminating unnecessary inspection trips and freeing up maintenance personnel to focus on scheduled repairs.

Based on data collected, the system will guide the user through corrective actions. If required, the user will be guided to collect additional data to identify root cause, and then prompted for corrective actions. SKF Microlog Inspector allows you to create your own formulas to calculate performance efficiencies and losses.

Work notifications

Clear, easy to use screens allow operators to create work notifications that can seamlessly interface with your organization's Computerized Maintenance Management System (CMMS).

Feature rich software completes the system

SKF @ptitude Inspector software completes the system, allowing for more in-depth analysis and the communication of machine condition data between operations, maintenance, engineering and plant management. SKF @ptitude Inspector incorporates an easy-to-use interface to speed up system implementation. Users can create and modify routes in a hierarchical form, define data collection points, types and schedules, define security levels and include specific instructions for operators. This data transfers to the device the minute the operator logs in.

SKF @ptitude Inspector Scheduler enables you to automatically schedule a specific action, such as generating a report to identify any missed or overdue collection points, or data that is out of compliance parameters. Reports and other actions can be scheduled to run upon completion of a data collection upload or another convenient time to allow you to focus on other pressing issues. Text or SMS messages keep you informed of any changes in machine condition.

System requirements for SKF Microlog Inspector mobile application

- Windows Mobile 2003 (Second Edition) Professional Operating System or newer (Windows Phone 7 is not supported)
- 128 MB of RAM minimum
- Minimum 15 MB of free RAM after installation
- QVGA screen resolution 240 × 320 pixels; full VGA screen resolution (480 × 640 pixels at 192 dpi supported)
- Microsoft .NET Compact Framework v3.5 (deployed with application)
- Microsoft SQL Compact Edition v3.5 (deployed with application)
- For Wireless Machine Condition Detector (WMCD) support, one of the following Bluetooth stacks are required:
 - Microsoft
 - Broadcom (Widcomm)
 - Bluetopia^{1,2})
- SKF @ptitude Analyst 2010 Edition or newer is required
- USB, LAN or 802.11 (WiFi)

System requirements for SKF Microlog Inspector Installer desktop application

- Microsoft Windows XP (limited support for Windows 7 32-bit, administrative privileges required)
- Microsoft .NET 2.0
- 25 MB free memory
- Microsoft ActiveSync 4.5 or Windows Mobile Device Center

¹) Only supported on Symbol/Motorola industrial hardware
²) Requires Windows Mobile 5.0 (or above)

SKF Microlog Inspector is available for purchase as a bundled system with a portable computer or as an application only for installation on customers' Windows Mobile devices. SKF @ptitude Analyst 2012 Edition software is required. Additional SKF Microlog Inspector licenses may be added at any time.

Specifications

Specifications	CMDM 6700 series I-Pro	CMDM 5860 series S-Pro
Physical characteristics		
Dimensions: L x W x D (length x width x depth)	195 x 80 x 34 mm (7.66 x 3.15 x 1.34 in.)	231 x 91 x 59 mm (9.1 x 3.6 x 2.3 in.)
Weight	491 g (17 oz.)	980 g (31 oz.)
Environmental		
Operating temperature range	-20 to +60 °C (-4 to +140 °F)	-20 to +40 °C (-4 to +104 °F)
Storage temperature range	-30 to +70 °C (-22 to +158 °F)	-40 to +70 °C (-40 to +158 °F)
Relative humidity	5 to 95%, non-condensing	5 to 95%, non-condensing
Environment sealing / rain and dust resistance	IP 67 compliant	IP 54 compliant
Drop specification	2,4 m (8 ft.) to concrete per MIL-STD 810G	1,8 m (6 ft.) to concrete
Power		
Battery type	Lithium ion, 3,7 V (4 000 mAh cells), customer replaceable	Lithium ion, 7,4 V (2 200 mAh cells), customer replaceable
Battery capacity	14,8 Wh	15,3 Wh
Communications		
Standard communication	USB, LAN, WiFi, Bluetooth	USB, WiFi, Bluetooth version 2.1 with BT Explorer
Camera		
Camera	Integrated 5 megapixel auto focus color camera with LED flash	Not available
Performance characteristics		
Operating system	Microsoft Windows embedded handheld 6.5.3	Microsoft Windows embedded handheld 6.5.3
Microprocessor	Texas Instrument 1 GHz OMAP3 multi-engine processor	TI OMAP 4430 dual-core processor, 1 GHz

Specifications (continued)

Specifications	CMDM 6700 series I-Pro	CMDM 5860 series S-Pro
Memory and storage		
RAM memory	512 MB	1 GB/2 GB flash RAM/ROM with the option of expansion with SD card up to 32 GB
Internal slots	Customer accessible micro-SD slot for removable memory card up to 32 GB	Secure Digital (SD), Flash card
Display	Transmissive VGA 89 mm (3.5 in.), 640 × 480 pixels, 16 bit color, high durability touch screen, LED backlight, ambient light sensor	94 mm (3.7 in.) VGA color display with touchscreen, 480 × 640 pixels
Keypad options		
Numeric	Large numeric keypad with backlit shifted plane legends	Large numeric keypad
QWERTY numeric	QWERTY numeric	Not available
Scanner / barcode imager / RFID Reader		
	EA30 high performance motion tolerant 2D imager; white LED illumination; red laser aimer optimized for all lighting conditions; 35 degree downward scan angle; capable of scanning all common 1D and 2D barcodes; 1D as small as 5 mil; PDF as small as 6,6 mil; data matrix as small as 7,5 mil; standard UPC codes from distances up to 33 cm (13 in.).	SE 950:1D standard range scan engine. Reading range: 10 cm to 12 m (3.9 in. to 39.3 ft.).
RFID Reader	Integrated or hand held RFID Reader	Not available
Regulatory approvals and compliance		
Electrical safety	1000CP01, 1000CP01U, 1000CP01C Safety: cULus Listed, DEMKO, BSMI EMC: Class B FCC/ICES EN, GOST-R Radio: FCC with HAC, Industry Canada, CE 0981, A-tick (AU), C-tick (NZ), NCC, OFTA, IDA, ICASA, POSTEL, NTC, ETA, SIRIM, ANATEL, 61 countries in total Environmental: EU Directives-WEEE; RoHS; batteries and accumulators, packaging and waste packaging	Certified to UL60950, CSA C 22.2 No. 60950, EN60950/IEC 950
Hazardous area ratings		
Hazardous area ratings	<i>Models CMDM 6710 and CMDM 6711:</i> Non-NI <i>Models CMDM 6720 and CMDM 6721:</i> cULus listing, ISA/ANSI 12.12.01 Class I, Division 2, Groups A, B, C and D Class II, Division 2, Groups F and G Class III, Division 2	<ul style="list-style-type: none"> • ATEX <ul style="list-style-type: none"> - II 2G Ex q (ib) IIC T4 Gb - PTB 13 ATEX 2019 X • IECEx <ul style="list-style-type: none"> - Ex q (ib) IIC T4 Gb - IECEx PTB13.0043X

SKF Microlog Inspector I-Pro system

Flexible, enabling technology to meet every inspection need

The handheld SKF Microlog Inspector devices offer advanced technology and ergonomic design that enhance effectiveness while easing the process of routine inspections.

The SKF Microlog Inspector data managers allow users to quickly and easily collect, store and analyze overall machine vibration, process and inspection data. Intuitive screens provide clear problem description and define and prioritize corrections according to preset parameters. Instructions are available at the push of a button to guide the user on the most appropriate response to take for changes in machine conditions.

A dynamic "to-be-collected" route filter constantly refreshes as data is collected, displaying only points that have not been collected.

SKF Microlog Inspector I-Pro key features

- Drop tested, dust-tight and water resistant, the SKF Microlog Inspector I-Pro is designed to withstand the most hostile industrial environments
- Barcode identification, radio frequency identification (RFID), Bluetooth and radio 802.11 b/g enabled functionality
- Models are available for use in hazardous areas requiring NI Class 1, Division 2 certification
- Easy to recognize displays and touch screen or keypad data entry enhances proficiency with minimal training

The SKF Microlog Inspector I-Pro system is available in the following configurations:

- CMDM 6700 series:
 - CMDM 6710: SKF Microlog Inspector I-Pro, non-NI kit, numeric keypad
 - CMDM 6710RF: SKF Microlog Inspector I-Pro, non-NI kit, numeric keypad, integrated RFID
 - CMDM 6711: SKF Microlog Inspector I-Pro, non-NI kit, QWERTY numeric keypad
 - CMDM 6712RF: SKF Microlog Inspector I-Pro, non-NI CE certified, numeric keypad, integrated RFID
 - CMDM 6713RF: SKF Microlog Inspector I-Pro, non-NI kit, numeric keypad, integrated RFID – Australia radio
 - CMDM 6714RF: SKF Microlog Inspector I-Pro, non-NI kit, numeric keypad, integrated RFID – New Zealand radio
 - CMDM 6720: SKF Microlog Inspector I-Pro, NI Class I, Division 2 certified, numeric keypad
 - CMDM 6720RF: SKF Microlog Inspector I-Pro, NI Class I, Division 2 certified, numeric keypad, integrated RFID
 - CMDM 6721: SKF Microlog Inspector I-Pro, NI Class I, Division 2 certified, QWERTY numeric keypad

Multi-language support

SKF Microlog Inspector includes the following languages installed:

- English
- Spanish
- Portuguese
- French
- German
- Swedish
- Finnish
- Korean
- Italian
- Bulgarian
- Traditional Chinese
- Simplified Chinese

Bundled systems that include SKF @ptitude Inspector software and the Wireless Machine Condition Detector (WMCD) or the wired Machine Condition Detector (MCD) are also available.



SKF Microlog Inspector CMDM 6700 series I-Pro system

CMDM 6700 series kit contents

The SKF Microlog Inspector I-Pro system contains the following accessories. Note that certain products will differ based on the model purchased. The kit contents listed below are applicable to the CMDM 6710, CMDM 6711, CMDM 6720 or CMDM 6721 SKF Microlog Inspector systems. Each kit contains:

- CMDM 6710, CMDM 6711, CMDM 6720 or CMDM 6721 SKF I-Pro handheld computer device
- Microlog Inspector application installed (single device license)
- CMAC 6160: Communication/Recharging dock, power adapter and power cable
- CMAC 6164 Lithium ion battery
- CMAC 6163: Micro-USB communication cable (dock to PC), 1,8 m (6 ft.)
- CMAC 6140: Belt holster
- CMAC 6162: Tethered stylus
- CMAC 6165: Memory card (4 GB)
- CMAC 6139: Screen protector
- CMAC 6161: Connection cover
- Built-in color camera
- User manual
- Universal power adapter (for non-US kits)

Note: Use of a LAN requires the CMAC 6156 Ethernet adapter, which is sold separately.



CMAC 6163 USB communication cable (dock to PC)



CMAC 6165 memory card (4 GB)



CMAC 6140 belt holster



CMAC 6161 connection cover



CMAC 6139 screen protector



CMAC 6160 docking station



CMAC 6160 power adapter



CMAC 6164 battery



CMAC 6162 stylus

Ordering information

- **CMDM 6710** SKF Microlog Inspector I-Pro, non-NI kit, numeric keypad with SKF Microlog Inspector application installed (single device license)
- **CMDM 6710RF** SKF Microlog Inspector I-Pro, non-NI kit, numeric keypad, integrated RFID with SKF Microlog Inspector application installed (single device license)
- **CMDM 6711** SKF Microlog Inspector I-Pro, non-NI kit, QWERTY numeric keypad with SKF Microlog Inspector application installed (single device license)
- **CMDM 6712RF** SKF Microlog Inspector I-Pro, non-NI CE certified, numeric keypad, integrated RFID with SKF Microlog Inspector application installed (single device license)
- **CMDM 6713RF** SKF Microlog Inspector I-Pro, non-NI kit, numeric keypad, integrated RFID – Australia radio, with SKF Microlog Inspector application installed (single device license)
- **CMDM 6714RF** SKF Microlog Inspector I-Pro, non-NI kit, numeric keypad, integrated RFID – New Zealand radio, with SKF Microlog Inspector application installed (single device license)
- **CMDM 6720** SKF Microlog Inspector I-Pro, NI Class I, Division 2 certified, numeric keypad with SKF Microlog Inspector application installed (single device license)
- **CMDM 6720RF** SKF Microlog Inspector I-Pro, NI Class I, Division 2 certified, numeric keypad, integrated RFID with SKF Microlog Inspector application installed (single device license)
- **CMDM 6721** SKF Microlog Inspector I-Pro, NI Class I, Division 2 certified, QWERTY numeric keypad with SKF Microlog Inspector application installed (single device license)

Optional accessories for the CMDM 6700 series

- **CMAC 6139:** Screen protector (package of five)
- **CMAC 6140:** Belt holster
- **CMAC 6160:** Communication/Recharging dock
- **CMAC 6161:** Connection cover
- **CMAC 6162:** Stylus with tether (package of five)
- **CMAC 6163:** USB cable, docking station to PC
- **CMAC 6164:** Lithium-ion battery
- **CMAC 6165:** Mini secure digital card (4 GB)

SKF Microlog Inspector S-Pro system

Rugged design and superior performance

The SKF Microlog Inspector S-Pro is an exceptionally reliable, rugged, mobile computer that is designed to capture your company's mission-critical machinery, inspection and process data. The SKF Microlog Inspector S-Pro, with ATEX Zone 1, IECEx, and Class I, Division 1 certification, meets your company's stringent safety requirements for use around flammable gasses, vapors, liquids, dusts or fibers. The CMDM 5860 has an IP 54 rating.

A dynamic "to-be-collected" route filter is included that constantly refreshes as data is collected, displaying only points that have not been collected.

Multi-language support

SKF Microlog Inspector includes the following languages installed:

- English
- Spanish
- Portuguese
- French
- German
- Swedish
- Finnish
- Italian
- Bulgarian
- Korean (CMDM 5600 series only)
- Traditional Chinese (CMDM 5600 series only)
- Simplified Chinese



SKF Microlog Inspector CMDM 5860 S-Pro

CMDM 5860 kit contents

Each SKF Microlog Inspector CMDM 5860 S-Pro kit contains the following items:

- CMDM 5860 SKF S-Pro data manager device
- SKF Microlog Inspector application installed (single device license)
- CMAC 6110: Communication/Recharging dock with power supply
- CMAC 6104: USB communication cable (dock to PC), 1,8 m (6 ft.)
- CMAC 6117: Lithium-ion battery
- CMAC 6157: Power adapter
- User manual

Note: LAN data transfer is not available; however, WiFi is.

Note: When hardware accessories (Machine Condition Detector [MCD] and cable) are connected to the SKF Microlog Inspector S-Pro CMDM 5860, the complete **system** is not ATEX or IECEx certified and may only be used in non-hazardous areas.



CMAC 6110 docking station



CMAC 6104 USB communication cable (dock to PC)



CMAC 6117 battery



CMAC 6157 universal power adapter

Optional accessories



CMAC 6153 leather holster

Ordering information

- **CMDM 5860** SKF Microlog Inspector S-Pro, ATEX Zone 1 certified bundle with SKF Microlog Inspector application installed (single device license)

Optional accessories for the CMDM 5800 series

- **CMAC 6104:** USB communication cable, dock to PC
- **CMAC 6110:** Docking station with power supply
- **CMAC 6117:** Battery
- **CMAC 6153:** Leather holster
- **CMAC 6157:** Universal power adapter

Software to support SKF Microlog Inspector

SKF @ptitude Analyst / SKF @ptitude Inspector

SKF @ptitude Analyst is a comprehensive software solution with powerful diagnostic and analytical capabilities. SKF @ptitude Analyst provides fast, efficient and reliable storage, analysis and retrieval of complex asset information and makes the information accessible throughout your organization. SKF @ptitude Analyst easily scales to your specific needs, whether it is operator inspection rounds, condition monitoring data collection or in-depth vibration analysis and expert advice.

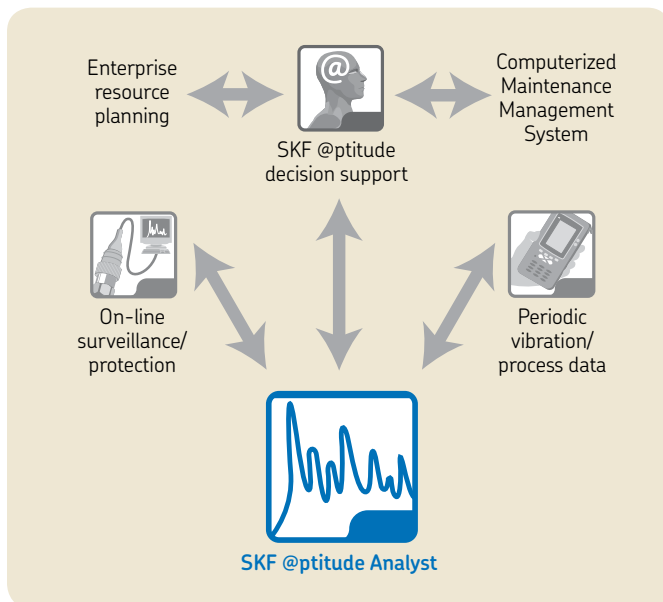

Features

- One software program to manage asset condition data from portable and on-line devices
- Easy for novice or experienced users to learn and use
- Interconnectivity with multiple enterprise-wide software programs and systems
- Scalable and flexible to meet your unique needs
 - Start with one of three base models and expand functionality according to your needs
 - Easy personalization for individual users
 - Application add-ons extend core functionality
 - User access control to support functional roles and department needs
 - User programmable functions compute your company's KPIs (Key Performance Indicators)
- Supports Oracle and Microsoft SQL Server database managers
- Compliance reporting and scheduling direct tasks and workforce
- Built-in Human Machine Interface (HMI)
- Email and SMS support

SKF @ptitude Analyst allows your operations, maintenance and reliability staff to view data from different sources using the same application, and communicate information to other departments in a customizable format.

SKF @ptitude Analyst integrates the SKF Microlog Analyzer, SKF Microlog Inspector and SKF Multilog data collection device ranges into one enterprise-wide software platform.

It can also incorporate data from other sources, such as OPC servers, and seamlessly interface with your organization's Computerized Maintenance Management System (CMMS), Enterprise Resource Planning (ERP) or other information management systems. In this way, SKF @ptitude Analyst's integrated platform forms the hub to share information, foster teamwork and facilitate consistent and reliable decision-making across functional departments.

S-Pro Models

- CMDM 5360
- CMDM 5460
- CMDM 5660
- CMDM 5700
- CMDM 5860

I-Pro Models

- CMDM 6200
- CMDM 6400
- CMDM 6500
- CMDM 6600
- CMDM 6700



Software tailored to the needs of the SKF Microlog Inspector

SKF @ptitude Inspector incorporates a simple user interface to speed up system implementation.

- Easily create and modify databases in a hierarchical form, define data collection points and types, create routes and then automatically sync with the SKF Microlog Inspector.
- Compliance reporting and scheduling allows a range of collection schedules that vary from day, week, month, day of year and multiple or repeat collections per time period. Reports identify missed or overdue collection points or data collection that is out of compliance parameters.

- SMS and text messages can be set up to keep you informed individually or as a group
- A variety of user-specified views includes multi-pane plots, window sizes and positions, a customizable toolbar and more to help optimize user productivity and efficiency.
- Standardized notes can be used to document observed machinery and process conditions, then combined with machine data and images to create a variety of reports.
- Data collected with the SKF Microlog Inspector and Wireless Machine Condition Detector is uploaded for analysis by your maintenance engineers. Events that occur in the higher frequency ranges, such as bearing and gear problems, can be detected by the WMCD with its "enveloped acceleration" capability, a signal processing technique that focuses on enhancing repetitive vibration signals that characterize such problems.

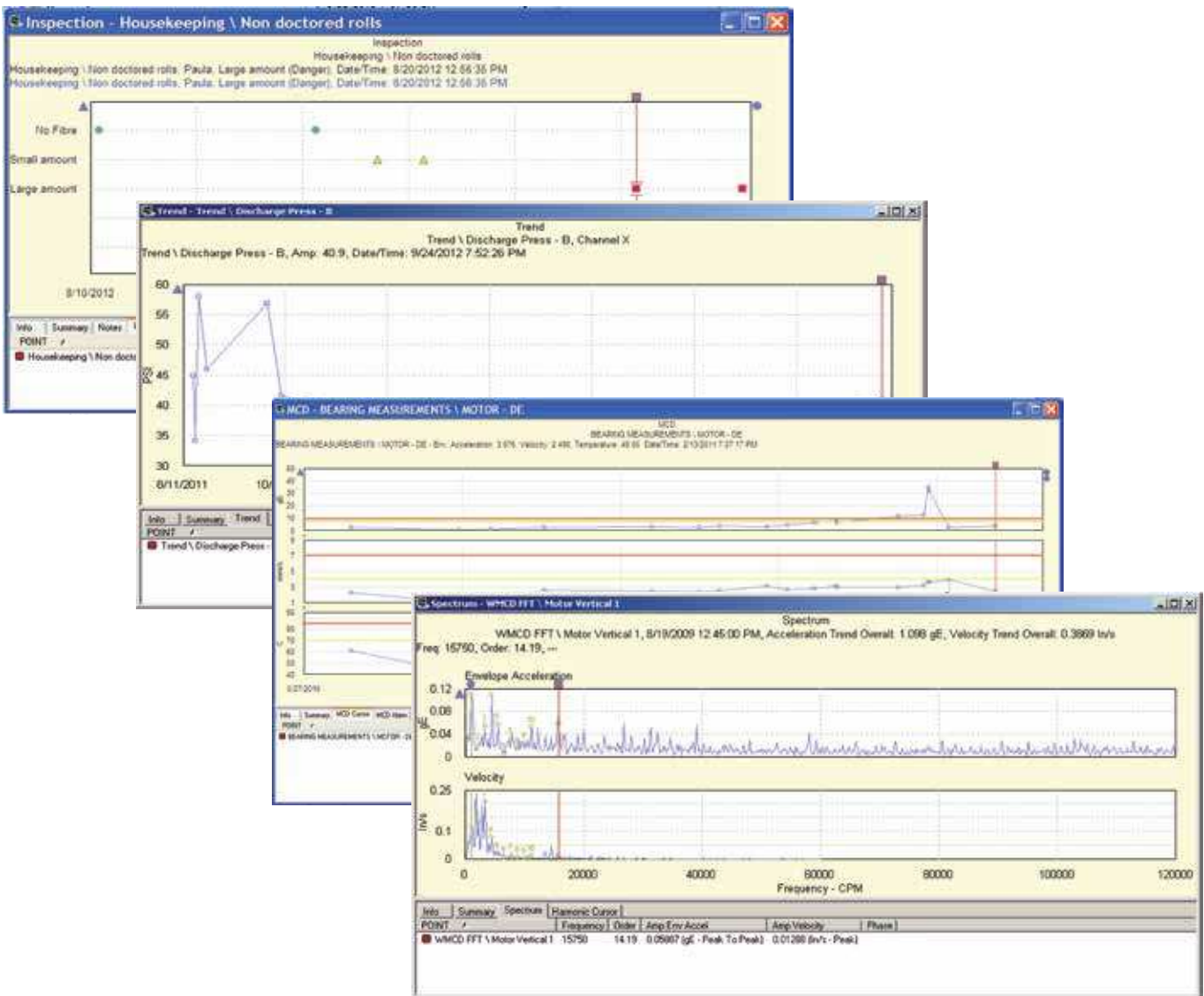

Examples of SKF @ptitude Inspector analysis.

SKF Machine Condition Detector

SKF @ptitude Inspector fully supports the SKF Microlog Inspector, SKF MARLIN, Machine Condition Detector (MCD) and the Wireless Machine Condition Detector (WMCD) POINT type (velocity, acceleration enveloping and temperature). All process data types are supported, including pressure, flow, r/min, temperature and AC or DC current. Instantly access points in alarm or view alarm status for a specific machine.

An Alarm Wizard helps calculate alarms for plant machinery, making this complex task almost effortless for the user.

- The Wireless Machine Condition Detector supports acquisition of Fast Fourier Transfer (FFT) data for the acceleration enveloping (gE) and velocity measurements. SKF @ptitude Inspector uploads and displays these dynamic data types effortlessly.

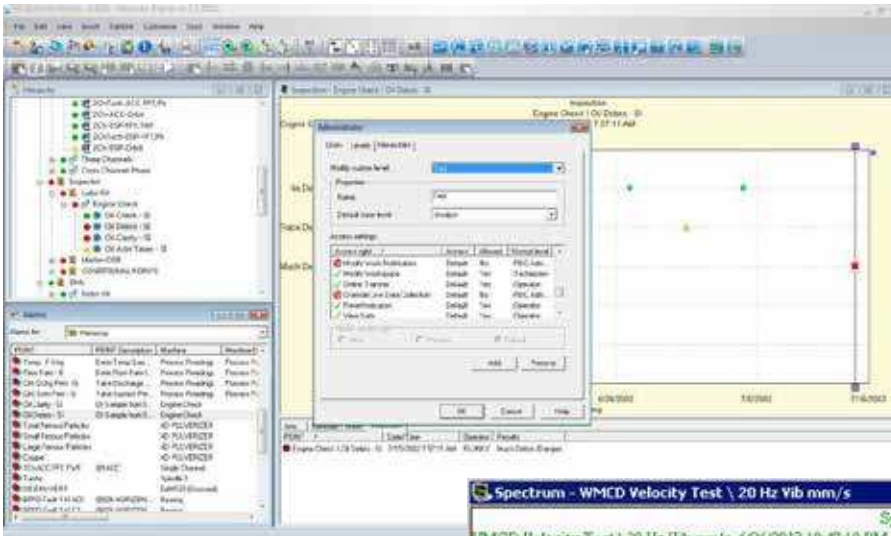

Examples of SKF @ptitude Analyst screens.

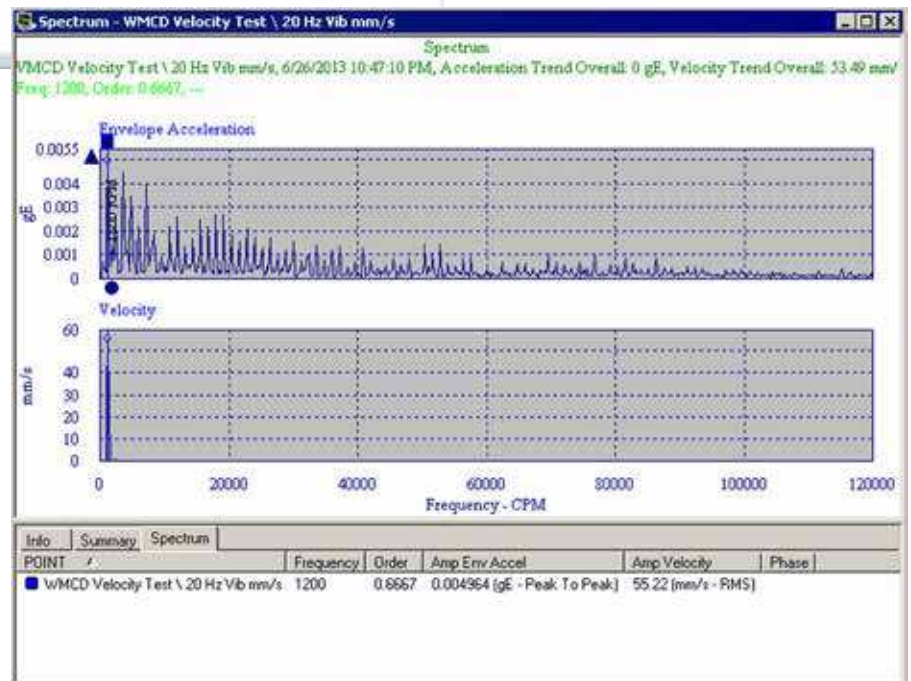

Features and capabilities

The following features and capabilities are available with the SKF @ptitude Inspector (CMSW 7200):

Device support

- SKF Microlog Inspector with Wireless Machine Condition Detector (WMCD)

Alarms

- View alarm status indicators directly at the hierarchy
- Alarm window:
 - Acknowledge alarms and enter comments or recommendations
 - Quickly find and identify all points in alarm within the hierarchy, group, route, workspace or machine
- Alarm details: Provides a summary of the type of alarms and status
- User defined alarm levels:
 - Public alarms that can be shared with other users
 - Private alarms that can only be used by specific users
 - Unlimited number of alarms that can be configured
- Overall alarm levels:
 - Danger high, alert high, alert low, danger low
 - Level alarm, out of window, in window

Alarm types

- Overall forecast
- Overall percent change
- Overall
- Inspection
- Machine condition detector
- Statistical alarm calculation with outlier removal

Graph displays

- Trend
- Spectrum
- Inspection
- Multiple hierarchy support

Graph display overlays

- Trend:
 - Single cursor
 - Notes indicators
 - Exponential curve line
 - Curve fit
- Spectrum:
 - Single cursor
 - Harmonic cursor with Set Speed function

Display tools

- Graph linking:
 - Display information area
 - On-screen text annotation
 - Percent of full scale setting
 - Auto scaling
 - Spectrum cursor micro-manipulation
 - Date range setting

Storage, file formats and networking

- Oracle support
- Microsoft SQL Server support
- Binary importing and exporting (.MAB)
- CSV (Excel) exporting
- Supports for LAN and WAN
- Support for Thin Client (Terminal) environments
- Operates with Citrix, Terminal Server and Microsoft Windows 2008 application server
- Unlimited number of:
 - Hierarchies
 - Collection points
 - Measurements
 - Workspaces

General

- Email and SMS support for:
 - Scheduled events, e.g., a scheduled report is generated
 - Unscheduled events, e.g., an alarm condition change
- Multiple languages available
 - Standard languages:
 - English
 - French
 - German
 - Portuguese
 - Spanish
 - Swedish
 - Non-standard languages:
 - Russian
 - Simplified Chinese
- True multi-processing operating environment allowing simultaneous background and foreground processing
- Consistent with Microsoft Windows functions:
 - “Right-click” functionality
 - Drag and drop
 - Cut, copy and paste
 - Context sensitive help
- Allows for complete integration of third party applications
- User preferences allow customization
- Complete user and installation manuals on installation DVD
- Product Support Plans (PSP) available
- Optional interfaces available:
 - OPC Client
 - CMMS (contact an SKF Sales Representative for details)
- Measurement archiving

Measurement types

- Acceleration enveloping (gE)
- Machine Condition Detector (MCD) velocity, acceleration enveloping and temperature
- Flow (GPM, LPM)
- Inspection (user definable)
- Operating hours
- Pressure (PSI and Bars)
- Machine speed

Measurement attributes

- Conditional POINTs (SKF Microlog Inspector and SKF MARLIN only)
- Imperial or Metric units
- Derived POINT: User definable mathematical formula to calculate values from data collected on one or more POINTs
- Display and storage of non-collection events
 - SKF Multilog IMx
 - SKF Microlog Inspector

Reporting

- Preserved reports: Enables you to maintain a history of reports
- Shared reports: Allows you to share and preconfigure reports for selected users
- Emailing of reports with PDF attachment: Send reports to individuals or groups of contacts
- Send reports to screen, HTML file, printer
- HTML file can be posted to internet, intranet, emailed
- HTML files can be opened and modified further using Microsoft Office products, such as Word, Excel or PowerPoint
- Customizable report content
- Data plots, supplemental information and digital images can be included in reports
- Report template types:
 - Blank
 - Last measurement
 - Exception
 - Overdue/Non-compliant
 - Pending overdue/non-compliant
 - Collection status
 - Route history / route statistics
 - Set statistics
 - Upload statistics
 - History
 - Inspection
 - Work notification
 - User defined
 - Compliance
- Report templates allow quick and easy report configuration for use and reuse
- Alarm acknowledgment comments/notes

Security and stability

- Supports definition of user profiles/roles
- Unlimited number of user profiles/roles
- Fully configurable user rights that allow you to read, view and have full access
- Access rights can be restricted to specific hierarchy or allow multiple hierarchy access
- Point setup change log:
 - Maintains a log of what was changed by whom and when
 - Preference setting determines if a reason message is required before allowed to make setup changes
- Communication with on-line devices is supported by Windows services
 - Multiple services may be used to provide a high degree of security
 - Service requires no user login
- Communication services are auto-restarted in case of failures
- DAD services system – email alerts

Templates and wizards

- Statistical alarm wizards with outlier removal use historical data to help refine overall alarms
- Hierarchy template wizard allows for rapid hierarchy creation and machine templates for reuse
- Report template allows for the custom configuration of reports and report templates for reuse and sharing
- Scheduler wizard helps configure and preset recurring activities such as report generation, data archival and task reminders

Installation and training

Installation and training are available through your local SKF Supplier or Representative.

Ordering information

- **CMSW 7400** SKF @ptitude Analyst software for SKF Microlog Analyzer, SKF Microlog Inspector, SKF MARLIN and SKF Multilog Systems (DMx, WMx, IMx, TMU, CMU)
- **CMSW 7200** SKF @ptitude Inspector

All models are available in single and multi-client configurations. Please contact your local SKF representative for multi-client model information.

Hardware requirements

Stand alone configuration

- Running SKF @ptitude Analyst / SKF @ptitude Inspector
- Running Oracle or Microsoft SQL Server database management system
- Storing data

Configuration	Minimum requirements	Recommended requirements
Operating system¹⁾	Windows 7 OR Windows XP Professional with Service Pack 2+	Windows
Processor²⁾	Intel 1.0 GHz, 32- or 64-bit, or better	Intel Core 2 Duo, 2.0 GHz, 32- or 64-bit, or better
RAM	4 GB	8 GB or more
Disk space available for standalone computer³⁾	1.2 GB	1.2 GB or more
DVD drive	One required	One required
Oracle / Microsoft SQL Server⁵⁾	Version 11g / SQL Server 2008 R2	Version 11g / SQL Server 2008 R2

USB port for SKF Microlog Analyzer / SKF Microlog Inspector / SKF MARLIN transfer and serial port for SKF Multilog IMx configuration.

Network configuration – Network Client

- Running SKF @ptitude Analyst / SKF @ptitude Inspector
- Running database client software

Network configuration for up to 35 Clients and one database. Installations of 50 Clients or greater will require an on-site assessment by our Field Service Engineers.

Configuration	Minimum requirements	Recommended requirements
Operating system¹⁾	Windows 7 OR Windows XP Professional with Service Pack 2+	Windows 7
Processor²⁾	Intel 1.0 GHz, 32- or 64-bit, or better	Intel Core 2 Duo, 2.0 GHz, 32- or 64-bit, or better
RAM	2.0 GB	4.0 GB or more
Disk space available for each network client	1.0 GB	1.0 GB or more
DVD drive	One required	One required
Oracle / Microsoft SQL Client⁵⁾	Version 10g, 11g / SQL Server 2008 R2, 2008	Version 11g / SQL Server 2008 R2

USB port for SKF Microlog Analyzer / SKF Microlog Inspector / SKF MARLIN transfer and serial port for SKF Multilog IMx configuration.

Network configuration – Database Server

- Running Oracle or Microsoft SQL Server database management system
- Storing data

Network configuration for up to 35 Clients and one database. Installations of 50 Clients or greater will require an on-site assessment by our Field Service Engineers.

Configuration	Minimum requirements	Recommended requirements
Operating system	Windows 2008 Server	Windows 2008 Server
Processor²⁾	Intel 2.0 GHz, 32- or 64-bit, or better	Intel Core 2 Duo, 3.0 GHz, 32- or 64-bit, or better
RAM	4 GB	8 GB or more
Quantity of hard drives⁴⁾	3	5
Disk space available³⁾	1.2 GB	1.2 GB or more
DVD drive	One required	One required
Oracle / Microsoft SQL Server⁵⁾	Version 10g, 11g / SQL Server 2008 R2, 2008	Version 11g / SQL Server 2008 R2

Network configuration – Application Server

- Running SKF @ptitude Analyst / SKF @ptitude Inspector

Network configuration for up to 35 Clients and one database. Installations of 50 Clients or greater will require an on-site assessment by our Field Service Engineers.

Configuration	Minimum requirements	Recommended requirements
Operating system¹⁾	Windows 7 OR Windows 2008 Server	Windows 7 OR Windows 2008 Server
Processor	Intel 1.0 GHz, 32- or 64-bit, or better	Intel Core 2 Duo, 3.0 GHz, 32- or 64-bit, or better
RAM	4 GB	8 GB or more
Disk space available	1.2 GB	1.2 GB or more
DVD drive	One required	One required

³⁾ These requirements ONLY apply to SKF @ptitude Analyst complete with database management system. Additional storage disk space is required for data.

⁴⁾ The major benefits of spreading Oracle across three or more hard disks at the server is the improved speed and improved recoverability of a previously archived database. The recommended five disk configuration provides the optimal protection for backup, recovery, indexing and speed. Disk/File configuration should ONLY be handled by an SKF Field Service Technician certified on SKF @ptitude Analyst. If using RAID, the combination of RAID 0 and RAID 1 is recommended over RAID 5.

⁵⁾ Oracle 10g Express Edition is supported under Windows XP 32-bit only. In a Network Client configuration, you must install Oracle 32-bit Client Software. If using Windows 7 (32- or 64-bit), then Oracle 11g must be installed.

Notice

If running other system configurations, please contact your local SKF Representative to inquire about compatibility.

¹⁾ Windows 7 (32- or 64-bit) Professional or Ultimate Editions (please visit the Windows 7 and UAC compatibility matrix in skf.com/cm), Microsoft.NET Framework 3.5, 4.0, Windows 4.5 Installer and Windows Mobile Device Center 6.1.

²⁾ These requirements apply to SKF @ptitude Analyst complete with database management system. Other applications running simultaneously may degrade performance. Hyper-threading should be disabled in some systems.

Product index

Model number	Product	CMDM 5360	CMDM 5460	CMDM 5660	CMDM 5700	CMDM 5860	CMDM 6200	CMDM 6400	CMDM 6500	CMDM 6600	CMDM 6700	Page
CMAC 3610	Temperature magnet probe tip											51
CMAC 3611	Magnetic probe tip											51
CMAC 3630	Probe tip replacement kit											52
CMAC 3714	BNC cable, VibPak to accelerometer						●	●	●	●		27
CMAC 3725	Cable, SKF I-Pro to VibPak						●	●				27
CMAC 4200-K-SL	Infrared thermometer						●	●	●	●	●	20
CMAC 6104	USB communication cable, docking station to PC	●	●	●		●	●	●	●	●		28
CMAC 6105	Stylus with tether						●	●				53
CMAC 6107	Cable, SKF I-Pro to MCD Pro IS						●	●				29
CMAC 6108	Cable, SKF I-Pro to infrared thermometer gun						●	●				29
CMAC 6109	Cable, SKF S-Pro to MCD Pro IS	●	●	●		●						30
CMAC 6110	Docking station	●	●	●		●						40
CMAC 6111	Battery						●	●				36
CMAC 6114	Screen protector						●	●				55
CMAC 6115	Snap-on adapter, SKF S-Pro to CMAC 6109 cable	●	●	●		●						30
CMAC 6117	Battery	●	●	●		●						36
CMAC 6134	Battery, non-NI								●	●		37
CMAC 6135	Multi-dock station								●	●		40
CMAC 6135-E	Quad Ethernet docking station									●		41
CMAC 6136	Docking station								●	●		41
CMAC 6137	Micro Secure Digital (SD) memory card								●	●		60
CMAC 6138	Stylus with tether								●	●		53
CMAC 6139	Screen protector								●	●	●	55
CMAC 6140	Holster								●	●	●	56
CMAC 6141	Cable, SKF S-Pro to MCD Pro IS or VibPak								●	●	●	31
CMAC 6142	Snap-on adapter, SKF I-Pro to CMAC 6141 cable								●	●		31
CMAC 6143	Battery, non-NI, for CMRF 6510/6530/6710/6730 RFID readers											39
CMAC 6144	Battery, NI, for CMRF 6520/6720 RFID reader											39
CMAC 6145	Two-bay charger for CMRF 6500 series RFID reader											45
CMAC 6147	Universal power supply for CMRF 6500 series RFID reader											46
CMAC 6148	Cable, SKF I-Pro to infrared thermometer gun								●	●	●	32
CMAC 6152	Leather case											57
CMAC 6153	Leather holster	●	●	●		●						57
CMAC 6154	Connection cover								●	●		58
CMAC 6155	Battery, NI								●	●		38
CMAC 6156	Ethernet adapter								●	●		44
CMAC 6157	Universal power adapter	●	●	●	●	●	●	●	●	●	●	45
CMAC 6158	Hand strap								●	●		63
CMAC 6159	Snap-on adapter, SKF I-Pro CMDM 6700 to CMAC 6141 cable										●	32
CMAC 6160	Docking station										●	42
CMAC 6161	Connection cover										●	59
CMAC 6162	Stylus with tether										●	54
CMAC 6163	USB communication cable, docking station to PC				●						●	28
CMAC 6164	Battery										●	37

Product index (continued)

Model number	Product	CMDM 5360	CMDM 5460	CMDM 5660	CMDM 5700	CMDM 5860	CMDM 6200	CMDM 6400	CMDM 6500	CMDM 6600	CMDM 6700	Page
CMAC 6165	Micro Secure Digital (SD) memory card										●	61
CMAC 6166-E	Quad Ethernet docking station										●	42
CMAC 6169	Docking station				●							43
CMAC 6170	Stylus with tether				●							54
CMAC 6171	Hand strap				●							63
CMAC 6172	Quad charging station				●							43
CMAC 6173	Ethernet adapter				●							44
CMAC 6174	Screen protector				●							56
CMAC 6175	Leather carrying case				●							58
CMAC 6176	Micro Secure Digital (SD) memory card				●							61
CMAC 6177	Battery				●							38
CMAC 6178	Aluminum SKF barcode tags											65
CMAC 6179	Plastic SKF barcode tags											65
CMAC 6181	Large, rugged RFID tag											66
CMAC 6182	Low profile, rugged RFID tag (FCC regions)											66
CMAC 6183	Low profile, rugged RFID tag (ETSI regions)											66
CMAC 8001	Charging station for CMVL 8000 WMCD											47
CMAC 8003	Belt clip											60
CMAC 8004	Power supply for CMAC 8001 charging station											46
CMAC 8600-LEAK-TAG-50	Leak tags for compressed air systems											65
CMAC 9600 series	Toolkits				●							62
CMDM 5860 series	SKF Microlog Inspector S-Pro system					●						73
CMDM 6700 series	SKF Microlog Inspector I-Pro system										●	70
CMRF 6500/CMRF 6700 series	Handheld RFID reader								●	●	●	22
CMSS 908-MD	Medium duty magnetic base											52
CMSS 2200	General purpose, low profile, side exit industrial accelerometer											64
CMSS 2600 series	SKF MARLIN QuickConnect (MQC) stud	●	●	●		●	●	●	●	●	●	17
CMSS 60139 series	Stinger probe											62
CMVL 3351	Power cord, UL, 110, US	●	●	●		●	●	●	●	●	●	47
CMVL 3600-IS	Machine Condition Detector (MCD) Pro IS	●	●	●		●	●	●	●	●	●	13
CMVL 8000 31784200	Wireless Machine Condition Detector (WMCD) Nylon belt holster		●	●	●	●	●	●	●	●	●	10 59

Please contact:

SKF USA Inc.

Condition Monitoring Center – San Diego

5271 Viewridge Court • San Diego, California 92123 USA

Tel: +1 858-496-3400 • Fax: +1 858-496-3531

Web: www.skf.com/cm

© SKF, @PTITUDE, MARLIN, MICROLOG and MULTIOLOG, are registered trademarks of the SKF Group.

Microsoft, Windows, Word, Excel, PowerPoint, SQL Server and ActiveSync are either registered trademarks or trademarks of Microsoft Corporation in the United States and/or other countries.

Citrix is a registered trademark of Citrix Systems, Inc.

Loctite is a registered trademark of Henkel Corporation.

Oracle is a registered trademark of Oracle Corporation.

All other trademarks are the property of their respective owners.

© SKF Group 2015

The contents of this publication are the copyright of the publisher and may not be reproduced (even extracts) unless prior written permission is granted. Every care has been taken to ensure the accuracy of the information contained in this publication but no liability can be accepted for any loss or damage whether direct, indirect or consequential arising out of the use of the information contained herein. SKF reserves the right to alter any part of this publication without prior notice.

Patents: US 4,768,380 · US 5,633,811 · US 5,679,900 · US 5,845,230 · US 5,852,351 · US 5,854,553 · US 5,854,994 · US 5,870,699 · US 5,907,491 · US 5,992,237 · US 6,006,164 · US 6,124,692 · US 6,138,078 · US 6,199,422 · US 6,202,491 · US 6,275,781 · US 6,301,514 · US 6,437,692 · US 6,489,884 · US 6,513,386 · US 6,633,822 · US 6,789,025 · US 6,792,360 · US 7,103,511 · US 7,697,492 · WO/2003/048714

PUB CM/P1 11644/12 EN · April 2015

Certain image(s) used under license from Shutterstock.com

