

Large induction heater with a 300 kg bearing heating capacity

TIH 220m

The large induction heater TIH 220m is a reliable and robust induction heater from the TIH...m range suitable for heating bearings up to a maximum weight of 300 kg (660 lb) and solid components up to a maximum weight of 150 kg (330 lb). Advanced design of the power electronics including current and overheating control, combined with user friendly features such as sliding arms and remote control are standard to the TIH...m range.

- Capable of heating a 220 kg (480 lb) bearing in just 20 minutes.
- Supplied standard with two yokes, allowing bearings with a bore diameter from 60 mm (2.3 in.) up to a maximum weight of 300 kg (660 lb) to be heated.
- Sliding arm for large size yoke.
- Available in two versions: 230 V/50–60 Hz and 400–460 V/50–60 Hz.



- A** Induction coil located outside the heater's housing enables a shorter heating time and lower energy consumption.
- B** Foldable bearing support arms allow larger diameter bearings to be heated, and reduce the risk of the bearing toppling during heating.
- C** Magnetic temperature probe, combined with a temperature mode pre-set at 110 °C (230 °F), helps prevent bearing overheating.
- D** Unique SKF remote control, with operating display and control panel, makes the heater easy and safe to use.
- E** Internal yoke storage, for smaller yoke(s), reduces the risk of yoke damage or loss.
- F** Integrated carrying handles allow for easy movement of the heater in the workshop.
- G** Sliding or swivel arm allows for easy and quick bearing replacement, reducing operator fatigue.

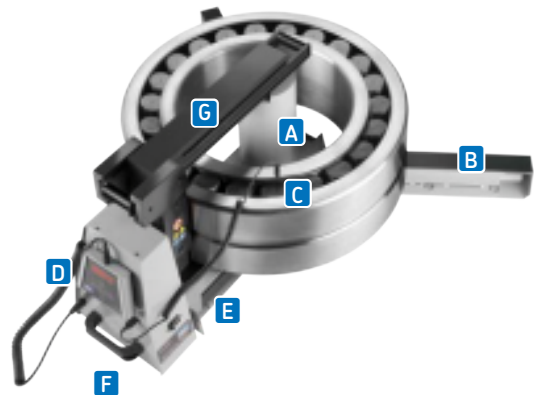

Technical data

Designation	TIH 220m
Max. bearing weight	300 kg (662 lb)
Bore diameter range	60–600 mm (2.3–23.6 in.)
Operating area (w × h)	250 × 255 mm (9.8 × 10 in.)
Coil diameter	140 mm (5.5 in.)
Standard yokes (included) to suit bearing/workpiece minimum bore diameter	100 mm (3.9 in.) 60 mm (2.3 in.)
SKF m ₂₀ performance	220 kg (480 lb)
Max. power consumption	10,0–11,5 kVA (400–460 V)
Voltage ¹⁾	
200–240 V/50–60 Hz	TIH 220m/LV
400–460 V/50–60 Hz	TIH 220m/MV
Temperature control	20 to 250 °C (68 to 482 °F)

Time control (minutes)	0–60
Demagnetisation according to SKF norms	<2 A/cm
Max. heating temperature ²⁾	250 °C (482 °F)
Dimensions (w × d × h)	750 × 290 × 440 mm (29.5 × 11.4 × 17.3 in.)
Total weight (incl. yokes)	86 kg (189 lb)

SKF induction heater range

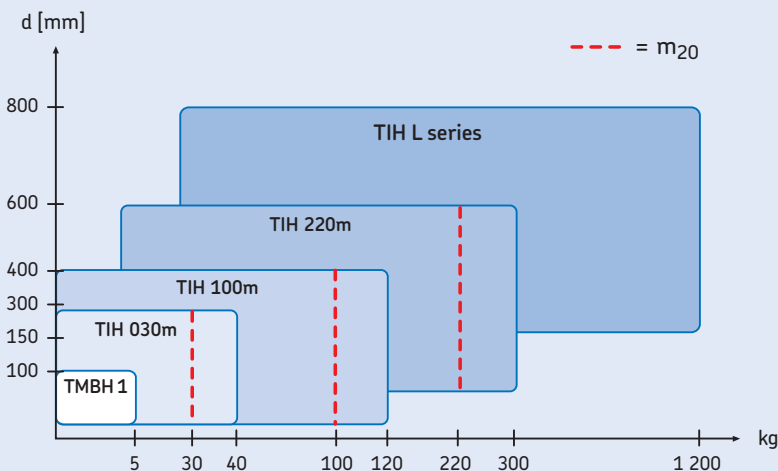

The comprehensive range of SKF induction heaters is suitable for most bearing heating applications. The chart gives general information on choosing an induction heater for bearing heating applications.³⁾

The SKF m₂₀ concept represents the weight (kg) of the heaviest SKF spherical roller bearing of series 231 which can be heated from 20 to 110 °C (68 to 230 °F) in 20 minutes. This defines the heater's power output instead of its power consumption. Unlike other bearing heaters, there is a clear indication of how long it takes to heat a bearing, rather than just the maximum bearing weight possible.

¹⁾ Some special voltage versions (e.g. 575V, 60Hz CSA ready) are available for specific countries. For additional information, please contact your local SKF authorised distributor.

²⁾ Depending on bearing or work piece weight. For higher temperatures, please contact SKF.

³⁾ For heating components other than bearings, SKF recommends consideration of a TIH L MB series heater. Contact SKF to help you select a suitable induction heater for your application.