

SKF TLMP series 1008/ 1018

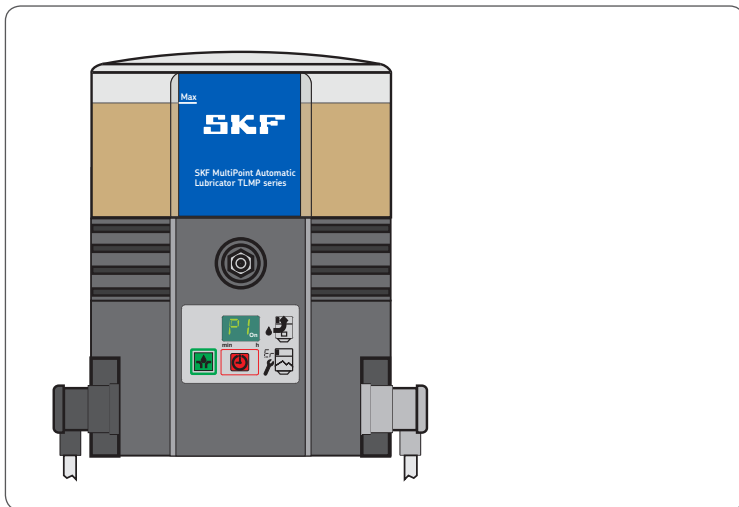

MP5460EN
951-171-030-EN
2017/01/02
Version 02



EC Declaration of incorporation following machinery directive 2006/42/EC, annex II, part 1 B

The manufacturer, SKF Maintenance Products, Kelvinbaan 16, 3439 MT Nieuwegein, The Netherlands, hereby declares that the partly completed machinery

Designation: Pump to supply lubricant during intermittent operation within a centralized lubrication system
 Type: TLMP 1008/TLMP 1018
 Part number: TLMP 1008/24DC, TLMP 1018/24DC, TLMP 1008/120V, TLMP 1018/120V, TLMP 1008/230V, TLMP 1018/230V
 Year of construction: See type identification plate

complies with the following basic safety and health requirements of the EC machinery directive 2006/42/EC at the time when first being launched in the market.

1.1.2, 1.1.3, 1.3.2, 1.3.4, 1.5.1, 1.5.6, 1.5.8, 1.5.9, 1.6.1, 1.7.1, 1.7.3, 1.7.4

The special technical documents were prepared following Annex VII part B of this directive. Upon justifiable request, these special technical documents can be forwarded electronically to the respective national authorities. The person empowered to assemble the technical documentation on behalf of the manufacturer is the head of standardization, See manufacturer's address.

Furthermore, the following directives and harmonized standards were applied in the respective applicable areas:

2011/65/EU	RoHS II
2014/30/EU	Electromagnetic compatibility Industry
2006/28/EC	Electromagnetic compatibility Automotive

Standard	Edition	Standard	Edition	Standard	Edition	Standard	Edition
DIN EN ISO 12100	2011	DIN EN 60947-5-1	2010	DIN EN 61000-6-2	2006	DIN EN 61000-6-4	2011
DIN EN ISO 809	2012	DIN EN 61131-2	2008	Amendment	2011	DIN EN 60947-5-1	2010
DIN EN 60204-1	2007	Amendment	2009	DIN EN 61000-6-3	2011		
Amendment	2010	DIN EN 60034-1	2011	Amendment	2012		
DIN EN ISO 50581	2013	DIN EN 61000-6-1	2007				

The partly completed machinery must not be put into service until the final machinery into which it is to be incorporated has been declared in conformity with the provisions of machinery directive 2006/42/EC and any other applicable directives.
 Nieuwegein, 2017/01/02

Sébastien David
 Manager Product Development and Quality
 Nieuwegein, The Netherlands
 SKF Maintenance Products



Legal disclosure

Manufacturer

SKF Maintenance Products
Kelvinbaan 16
3439 MT Nieuwegein
The Netherlands
www.mapro.skf.com
www.skf.com/lubrication

Training courses

In order to provide a maximum of safety and economic viability, SKF carries out detailed training courses. It is recommended that the training courses are attended. For more information please contact the respective SKF Service address.

Copyright

© Copyright SKF.
All rights reserved.

Warranty

The instructions do not contain any information on the warranty. This can be found in our general terms and conditions.

Disclaimer

The manufacturer shall not be held responsible for damages caused by:

- non appropriate use
faulty assembly, operation, setting, maintenance, repair, negligence or accidents
- use of inappropriate lubricants
- improper or late response to malfunctions
- unauthorized modifications of the product
- the use of non-original
SKF spare parts

Liability for loss or damage resulting from the use of our products is limited to the maximum purchase price. Liability for consequential damages of whatever kind is excluded.

























Table of contents



EC Declaration of incorporation following machinery directive 2006/42/EC	2
Explanation of symbols, signs and abbreviations.....	6
1. Safety instructions	8
1.1 General safety instructions	8
1.2 General behaviour when handling the product	8
1.3 Intended use	9
1.4 Foreseeable misuse	9
1.5 Painting of plastic parts.....	9
1.6 Modifications of the product	10
1.7 Prohibition of certain activities	10
1.8 Inspections prior to delivery	10
1.9 Other applicable documents.....	10
1.10 Markings on the product	11
1.11 Notes related to the type identification plate	11
1.12 Notes related to the CE marking	11
1.13 Persons authorized to operate the pump	12
1.14 Briefing of external technicians.....	12
1.16 Transport, installation, maintenance, malfunctions, repair, shutdown, disposal.....	13
1.17 Initial commissioning, daily start-up	14
1.18 Cleaning	14
1.19 Residual risks.....	15
2. Lubricants	17
2.1 General information	17
2.2 Selection of lubricants	17
2.3 Material compatibility	17
2.4 Temperature characteristics.....	17
2.5 Ageing of lubricants	18
2.6 Recommended temperature range for SKF lubricants	19
3. Overview, functional description	20
3.1 Changing the output volume of the SSV metering devices.....	22
3.2 Return of unneeded lubricant to the pump	23
3.3 Membrane keypad.....	24
3.4 Displays in the display mode	25
3.5 Displays in the programming mode	25
4. Technical data.....	28
4.1 General technical data	28
4.2 Electrics.....	29
4.3 Factory settings of pumps.....	30
4.4 Tightening torques.....	31
4.5 Necessary lubricant consistencies in case of intermittent low level signal....	31
4.6 Useable reservoir volume	32
4.7 Lubricant requirement for priming of an empty pump	32
5. Delivery, returns, and storage.....	33
5.1 Delivery	33
5.2 Returns	33
5.3 Storage.....	33
6. Assembly	34
6.1 General information	34
6.2 Attachment.....	34

6.3	Minimum assembly dimensions	35	11.4	Tubing and connectors	47
6.4	Connecting dimensions.....	36	11.5	Membrane keypad	48
6.5	Electrical connection.....	37	11.6	Pump element.....	48
6.6	Priming of pumps	38	11.7	Adapter M22 x 1.5	48
6.7	Programming	39	11.8	Indicator pin fitting.....	48
7.	Start-up	40	11.9	Reservoir.....	49
7.1	General information	40	11.10	Housing cover replacement kit.....	49
7.2	Triggering an additional lubrication cycle.....	40	11.11	V DC motors.....	50
8.	Operation, shutdown and disposal	41	11.12	motor connections VDC.....	50
8.1	General information	41	11.13	Electrical connections.....	50
8.2	Filling the reservoir during operation.....	41	11.14	Control printed circuit board replacement kit.....	50
8.3	Temporary shutdown	41	12.	Circuit diagrams	51
8.4	Shutdown and disposal	41	12.1	Legend	51
9.	Maintenance, cleaning and repair	42	12.2	Core assignment of the connection plugs	52
9.1	General information	42	12.3	Circuit diagram 24 V DC, with square plug	53
9.2	Maintenance.....	42	12.4	Circuit diagram 120 V AC, with square plug.....	54
9.3	Cleaning	42	12.5	Circuit diagram 230 V AC, with square plug.....	55
9.4	Replacement of the membrane keypad	42			
10.	Troubleshooting	43			
11.	Spare parts	47			
11.1	SSV metering devices.....	47			
11.2	Kit of seals.....	47			
11.3	Foam filter.....	47			

Explanation of symbols, signs and abbreviations

The following abbreviations may be used within these instructions. Symbols within safety notes mark the kind and source of the hazard.

	General warning		Dangerous electrical voltage		Risk of falling		Hot surfaces
	Unintentional intake		Crushing hazard		Pressure injection		Suspended load
	Electrostatically sensitive components		Risk of explosion		Explosion-protected component		
	Wear personal protective equipment (goggles)		Wear personal protective equipment (face shield)		Wear personal protective equipment (gloves)		Wear personal protective equipment (protective clothes)
	Wear personal protective equipment (safety shoes)		Release the product.		General obligation		
	Keep unauthorized persons away		Protective earth		Safety extra-low voltage (SELV)		Safe galvanic isolation (SELV)
	CE marking		Disposal, recycling		Disposal of waste electrical and electronic equipment		

	Warning level	Consequence	Probability	Symbol	Meaning
	DANGER	Death, serious injury	imminent	●	Chronological guidelines
	WARNING	Serious injury	possible	○	Lists
	CAUTION	Minor injury	possible	☞	Refers to other facts, causes, or consequences
	NOTICE	Property damage	possible		

Abbreviations and conversion factors					
re.	regarding	°C	degrees Celsius	°F	degrees Fahrenheit
approx.	approximately	K	Kelvin	Oz.	Ounce
i.e.	that is	N	Newton	fl. oz.	fluid ounce
etc.	et cetera	h	hour	in.	inch
poss.	possibly	s	second	psi	pounds per square inch
if appl.	if applicable	d	day	sq.in.	square inch
a.a.r.	as a rule	Nm	Newtonmeter	cu. in.	cubic inch
incl.	including	ml	millilitre	mph	miles per hour
min.	minimum	ml/d	millilitre per day	rpm	revolutions per minute
max.	maximum	cc	cubic centimetre	gal.	gallon
min.	minute	mm	millimetre	lb.	pound
etc.	et cetera	l	litre	hp	horse power
e.g.	for example	dB (A)	Sound pressure level	kp	kilopound
kW	kilowatt	>	greater than	fpsec	feet per second
U	Voltage	<	less than	Conversion factors	
R	resistance	±	plus/minus	Length	1 mm = 0.03937 in.
I	current	∅	diameter	Area	1 cm ² = 0.155 sq.in
V	volt	kg	kilogram	Volume	1 ml = 0.0352 fl.oz.
W	watt	rh	relative humidity		1 l = 2.11416 pints (US)
AC	alternating current	≈	about	Mass	1 kg = 2.205 lbs
DC	direct current	=	equal to		1 g = 0.03527 oz.
A	ampere	%	per cent	Density	1 kg/cc = 8.3454 lb./gal(US)
Ah	Ampere hour	‰	per mille		1 kg/cc = 0.03613 lb./cu.in.
Hz	Frequency [Hertz]	≥	greater than	Force	1 N = 0.10197 kp
nc	normally closed	≤	less than	Pressure	1 bar = 14.5 psi
no	normally open contact	mm ²	square millimetre	Temperature	°C = (°F-32) x 5/9
OR	logical OR	rpm	revolutions per minute	Output	1 kW = 1.34109 hp
&	logical AND			Acceleration	1 m/s ² = 3.28084 ft./s ²
				Speed	1 m/s = 3.28084 fpsec.
					1 m/s = 2.23694 mph

1. Safety instructions

1.1 General safety instructions

- The owner must ensure that safety information has been read by any persons entrusted with works on the product or by those persons who supervise or instruct the before-mentioned group of persons. In addition, the owner must also ensure that the relevant personnel are fully familiar with and have understood the contents of the Instructions. It is prohibited to commission or operate the product prior to reading the Instructions.
- These Instructions must be kept for further use.
- The described products were manufactured according to the state of the art. Risks may, however, arise from a usage not according to the intended purpose and may result in harm to persons or damage to material assets.
- Any malfunctions which may affect safety must be remedied immediately. In addition to these Instructions, general statutory regulations for accident prevention and environmental protection must be observed.

1.2 General behaviour when handling the product

- The product may only be used in awareness of the potential dangers, in proper technical condition, and according to the information in these instructions.
- Familiarize yourself with the functions and operation of the product. The specified assembly and operating steps and their sequences must be observed.
- Any unclear points regarding proper condition or correct assembly/ operation must be clarified. Operation is prohibited until issues have been clarified.
- Unauthorized persons must be kept away.
- Precautionary operational measures and instructions for the respective work must be observed.
- Responsibilities for different activities must be clearly defined and observed. Uncertainty seriously endangers safety.
- Safety-related protective and emergency devices must not be removed, modified or affected otherwise in their function and are to be checked at regular intervals for completeness and function.
- If protective and safety equipment has to be dismantled, it must be reassembled immediately after finishing the work, and then checked for correct function.
- Remedy occurring faults in the frame of responsibilities. Immediately inform your superior in the case of faults beyond your competence.
- Wear personal protective equipment.
- Never use parts of the centralized lubrication system or of the machine as standing or climbing aids.

1. Safety instructions

1.3 Intended use

Supply of lubricants within a centralized lubrication system following the specifications, technical data and limits stated in these Instructions:

Usage is allowed exclusively for professional users in the frame of commercial and economic activities.

1.4 Foreseeable misuse

Any usage differing from the one stated in these Instructions is strictly prohibited. It is expressly forbidden:

- outside the indicated operating temperature range
- with non-specified means of operation
- without adequate pressure relief valve
- in continuous operation
- In areas with aggressive or corrosive materials (e.g. high ozone pollution). These may affect seals and painting.
- in areas with harmful radiation (e. g. ionising radiation)

- to supply, transport, or store hazardous substances and mixtures in accordance with annex I part 2-5 of the CLP regulation (EG 1272/2008) and marked with GHS01 - GHS06 and GHS08 hazard pictograms.
- Use to feed, forward, or store gases, liquefied gases, dissolved gases, vapours, or fluids whose vapour pressure exceeds normal atmospheric pressure (1013 mbar) by more than 0.5 bar at the maximum permissible operating temperature.

1.5 Painting of plastic parts

Painting of any plastic parts or seals of the described products is expressly prohibited. Remove pump or completely tape plastic parts of pump before painting the superior machine

1.6 Modifications of the product

Unauthorized conversions or modifications may result in unforeseeable impacts on safety. Therefore, any unauthorized conversions or modifications are expressly prohibited.

1.7 Prohibition of certain activities

Due to potential sources of faults that may not be visible or due to legal regulations the following activities may be carried out by manufacturer specialists or authorized persons only:

- Repairs or changes to the drive
- Replacement of or changes on the pistons of the pump elements

1.8 Inspections prior to delivery

The following inspections were carried out prior to delivery:

- Safety and functional tests
- Electrical inspections following DIN EN 60204-1:2007 / VDE 0113-1:2007.

1.9 Other applicable documents

In addition to these instructions, the following documents must be observed by the respective target group:

- Operational instructions and approval rules
 - Safety data sheet of the lubricant used
- Where appropriate:
- Project planning documents
 - Any documents of other components required to set up the centralized lubrication system

1. Safety instructions

1.10 Markings on the product



Warning of dangerous electrical voltage, AC pumps only



Rotational direction of the pump

1.11 Notes related to the type identification plate

The type identification plate states important characteristics such as type designation, order number, and regulatory characteristics. To ensure that the loss of data due to an illegible type identification plate is avoided, the characteristics should be entered in the Instructions.

Model: _____

P. No. _____

S. No. _____

Year of construction _____

24 VDC

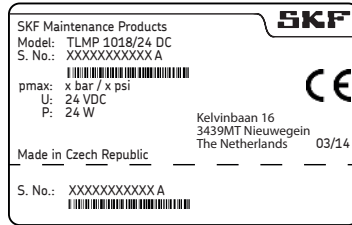

120 VAC

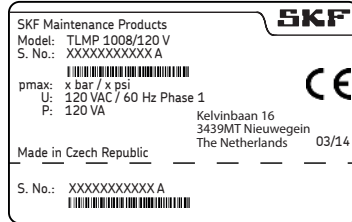

240 VAC

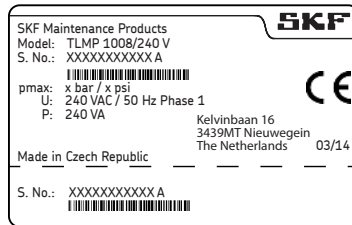

1.12 Notes related to the CE marking

CE marking is effected following the requirements of the applied directives:

- 2014/30/EU Electromagnetic compatibility
- 2011/65/EU (RoHS II) Directive on the restriction of the use of certain hazardous substances in electrical and electronic equipment

Reference on Low Voltage Directive 2014/35/EU

The protective regulations of Low Voltage Directive 2014/35/EU are fulfilled according to annex I (1.5.1) of Machinery Directive 2006/42/EC.

Reference on Pressure Equipment Directive 2014/68/EU

Because of its performance data the product does not achieve the limit values defined in Article 4 (1) (a) (i) and is therefore excluded from the scope of application of Pressure Equipment Directive 2014/68/EU following Article 4 (3).

1.13 Persons authorized to operate the pump

1.13.1 Operator

A person who is qualified by training, knowledge and experience to carry out the functions and activities related to normal operation. This includes avoiding possible hazards that may arise during operation.

1.13.2 Specialist in mechanics

Person with appropriate professional education, knowledge and experience to detect and avoid the hazards that may arise during transport, installation, start-up, operation, maintenance, repair and disassembly.

1.13.3 Specialist in electrics

Person with appropriate professional education, knowledge and experience to detect and avoid the hazards that may arise from electricity.

1.14 Briefing of external technicians

Prior to commencing the activities, external technicians must be informed by the operator of the company safety provisions, the applicable accident prevention regulations to be maintained, and the functions of the superordinate machine and its protective devices.

1.15 Provision of personal protective equipment

The operator must provide suitable personal protective equipment for the respective location of operation and the purpose of operation. For work in potentially explosive atmospheres this also includes ESD clothing and ESD tools.

1. Safety instructions

1.16 Transport, installation, maintenance, malfunctions, repair, shutdown, disposal.

- All relevant persons must be informed of the activity prior to starting any work. Observe the precautionary operational measures and work instructions.
- Carry out transport using suitable transport and hoisting equipment on suitable ways only.
- Maintenance and repair work can be subject to restrictions in low or high temperatures (e.g. changed flow properties of the lubricant). Therefore, where possible, try to carry out maintenance and repair work at room temperature.
- Prior to performing work, the product and the machine, into which the product will be integrated, must be depressurized and secured against unauthorized activation.
- Ensure through suitable measures that movable or detached parts are immobilized during the work and that no limbs can be caught in between by inadvertent movements.
- Assemble the product only outside of the operating range of moving parts, at an adequate distance from sources of heat or cold. Other units of the machine or vehicle must not be damaged or impaired in their function by the installation.
- Dry or cover wet, slippery surfaces accordingly.
- Cover hot or cold surfaces accordingly.
- Work on electrical components must be carried out by electrical specialists only. Observe any waiting periods for discharging, if necessary. Carry out works on electrical components only while the system is depressurized and use voltage isolated tools suitable for electrical works only.
- Carry out electrical connections only according to the information in the valid wiring diagram and taking the relevant regulations and the local connection conditions into account.
- Do not touch cables or electrical components with wet or damp hands.
- Fuses must not be bypassed. Replace defective fuses always by fuses of the same type.
- Ensure proper grounding of the product.
- Ensure proper connection of the protective conductor.
- Undertake drilling at non-critical, non-load bearing parts only. Use any available boreholes. Do not damage lines and cables when drilling.
- Observe possible abrasion points. Protect the parts accordingly.

- All components used must be designed for:
 - maximum operating pressure
 - maximum / minimum ambient temperature
 - the lubricant to be supplied
 - the ATEX zone required
 - the operating / ambient conditions at the place of usage.
- No parts of the centralized lubrication system may be subjected to torsion, shear, or bending.
- Check all parts prior to their usage for contamination and clean, if necessary.
- Lubricant lines should be primed with lubricant prior to installation. This makes the subsequent ventilation of the system easier.
- Observe the specified tightening torques. When tightening, use a calibrated torque wrench.
- When working with heavy parts use suitable lifting tools.
- Avoid mixing up or wrong assembly of dismantled parts. Mark these parts accordingly.

1.17 Initial commissioning, daily start-up

Ensure that:

- All safety devices are completely available and functional
- All connections are correctly connected
- All parts are correctly installed
- All warning labels on the product are present completely, highly visible and undamaged
- Illegible or missing warning labels are to be replaced without delay

1.18 Cleaning

- Risk of fire and explosion when using inflammable cleaning agents. Only use non-flammable cleaning agents suitable for the purpose.
- Do not use aggressive cleaning agents.
- Thoroughly remove residues of cleaning agents from the product.
- Do not use steam jet and high pressure cleaners. Electrical components may be damaged. Observe the IP type of protection of the pump.
- Cleaning work may not be carried out on energized components.
- Mark damp areas accordingly.

1.19 Residual risks

Residual risk	Possible in life cycle											Prevention/ remedy
Personal injury/ material damage due to falling of raised parts	A	B	C				G	H	K			Keep unauthorized persons away. No people may remain under suspended loads. Lift parts with adequate lifting devices.
Personal injury/ material damage due to tilting or falling of the product because of non-observance of the stated tightening torques		B	C				G					Observe the specified tightening torques. Fix the product only to components with sufficient load capacity. If no tightening torques are stated, apply tightening torques according to the screw size characteristics for 8.8 screws.
Personal injury/ material damage due to electric shock in case of damage to the connection cable		B	C	D	E	F	G	H			Check the connection cable with regard to damages before the first usage and then at regular intervals. Do not mount cable to moving parts or friction points. If this cannot be avoided, use spring coils respectively protective conduits.	
Personal injury/ damage to material due to spilled or leaked lubricant		B	C	D		F	G	H	K			Be careful when filling the reservoir and when connecting or disconnecting lubricant feed lines. Always use suitable hydraulic screw connections and lubrication lines for the stated pressures. Do not mount lubrication lines to moving parts or friction points. If this cannot be avoided, use spring coils respectively protective conduits.
Life cycles: A = transport, B = installation, C = initial start-up, D = operation, E = cleaning, F = maintenance, G = fault, repair, H = shutdown, K = disposal												

Residual risk	Possible in life cycle							Prevention/ remedy	
Bursting reservoir if filled by a high-performance pump			C	D				Monitor the filling procedure and stop it when reaching the max marking of the reservoir	
Contact with stirring paddle during "test operation" without reservoir after repair.							G	Operate pump with reservoir always	
Contamination of the environment with lubricant and wetted parts			C	D		F	G	K	Dispose of the parts following the relevant legal/ operational regulations
Strong heating of the motor due to a blockade			C	D					Switch pump off, let parts cool down, eliminate cause.
Damage of the control pcb due to electrostatic discharge when replacing a defective membrane keypad							G		Avoid electrostatic charge. Use ESD tools and ESD protective clothes, wear a grounding bracelet
Loss of electrical protective functions due to fault assembly of the control pcb due to faulty assembly of the control pcb							G		After the installation carry out a safety check following DIN EN 60204-1 (conduct and scope of test, see Service instructions 951-151-000)
Life cycles: A = transport, B = installation, C = initial start-up, D = operation, E = cleaning, F = maintenance, G = fault, repair, H = shutdown, K = disposal									

2. Lubricants

2.1 General information

Lubricants are used specifically for certain application purposes. In order to fulfil their tasks, lubricants must fulfil various requirements to varying extents.

The most important requirements for lubricants are:

- reduction of abrasion and wear
- Corrosion protection
- noise minimisation
- protection against contamination or penetration of foreign objects
- cooling (primarily with oils)
- longevity (physical/ chemical stability)
- economic and ecological aspects

2.2 Selection of lubricants

SKF considers lubricants to be an element of system design. A suitable lubricant is selected already when designing the machine and forms the basis for the planning of a centralized lubrication system.

The selection is made by the manufacturer or operator of the machine, preferably together with the lubricant supplier based on the requirement profile defined.

Should you have little or no experience with the selection of lubricants for centralized lubrication systems, please contact SKF.

If required we will be glad to support customers to select suitable components for feeding the selected lubricant and to plan and design their centralized lubrication system.

You will avoid possible downtimes through damage to your machine or system or damage to the centralized lubrication system.

2.3 Material compatibility

Lubricants must generally be compatible with the following materials:

- steel, grey iron, brass, copper, aluminium
- NBR, FPM, ABS, PA, PU

2.4 Temperature characteristics

The lubricant used must be suitable for the specific operating temperature of the product. The viscosity required for proper operation of the product must be adhered to and must not be exceeded in case of low temperatures nor fall below specification in case of high temperatures. Specified viscosities, see chapter Technical data.

2.5 Ageing of lubricants

After a prolonged downtime of the machine, the lubricant must be inspected prior to re-commissioning as to whether it is still suitable for use due to chemical or physical ageing. We recommend that you undertake this inspection already after a machine downtime of 1 week.

If doubts arise as to a further suitability of the lubricant, please replace it prior to re-commissioning and, if necessary, undertake initial lubrication manually.

It is possible for lubricants to be tested in the company's laboratory for their suitability for being pumped in centralized lubrication systems (e.g. "bleeding").

Please contact SKF if you have further questions regarding lubricants.

You may request an overview of the lubricants tested by SKF.

Only lubricants specified for the product may be used. Unsuitable lubricants may lead to a failure of the product.

Do not mix lubricants. This may have unforeseeable effects on the usability and therefore on the function of the centralized lubrication system.

When handling lubricants the relevant safety data sheets and hazard designations, if any, on the packaging have to be observed.



Due to the multitude of possible additives, individual lubricants, which according to the manufacturer's data sheets fulfil the necessary specification, may not, in fact, be suitable for use in centralized lubrication systems (e. g. incompatibility between synthetic lubricants and materials). In order to avoid this, always use lubricants tested by SKF.

2.6 Recommended temperature range for SKF lubricants

Approved SKF lubricants TLMP series	Temperature	
	Minimum	Maximum
LGHB 2	0 °C	70 °C
LGGB 2	-25 °C	50 °C
LGMT 2	-10 °C	40 °C
LGMT 3	-10 °C	50 °C
LGWA 2	-10 °C	50 °C
LGWM 1	-10 °C	25 °C
LGWM 2	-25 °C	70 °C
LGEV 2	10 °C	70 °C
LGHP 2	-10 °C	70 °C
LGEP 2	-10 °C	30 °C
LGEM 2	-10 °C	50 °C
LGFP 2	-10 °C	70 °C
LGFP 2	-10 °C	70 °C
LGFP 2	-10 °C	70 °C
LGFP 2	-10 °C	70 °C
LGFP 2	-10 °C	70 °C
LGFP 2	-10 °C	70 °C
LGFP 2	-10 °C	70 °C

3. Overview, functional description

1 reservoir

The lubricant is stored in the reservoir.

2 Filler fitting

The filler fitting serves to fill the reservoir with lubricant.

3 Membrane keypad

The membrane keypad serves to display operation and fault messages and to change parameters (programming) in the case of pumps with controller.

4 Pump housing

The housing comprises the motor and control printed circuit boards and connection options (plugs).

Overview Fig. 1

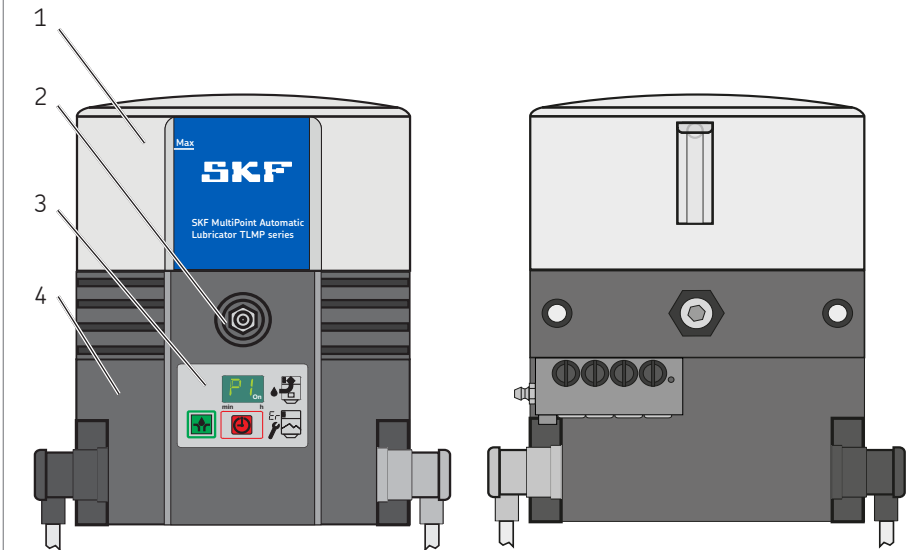

5 Power supply

Serves to connect the pump to an external power supply.

6 Signal line

Serves to connect the pump to an external control or signal device.

7 Metering devices

Serve to meter and distribute lubricant as well as to switch off the pump by means of an indicator pin and proximity switch after reaching the preset number of operating cycles.

8 Reservoir venting device

Serves to vent the reservoir when filling it with lubricant or to vent the reservoir during operation.

13 Emergency lubrication fitting

Serves to provide the connected lubrication points with lubricant, e.g. in case of a defect of the pump.

Overview Fig. 2

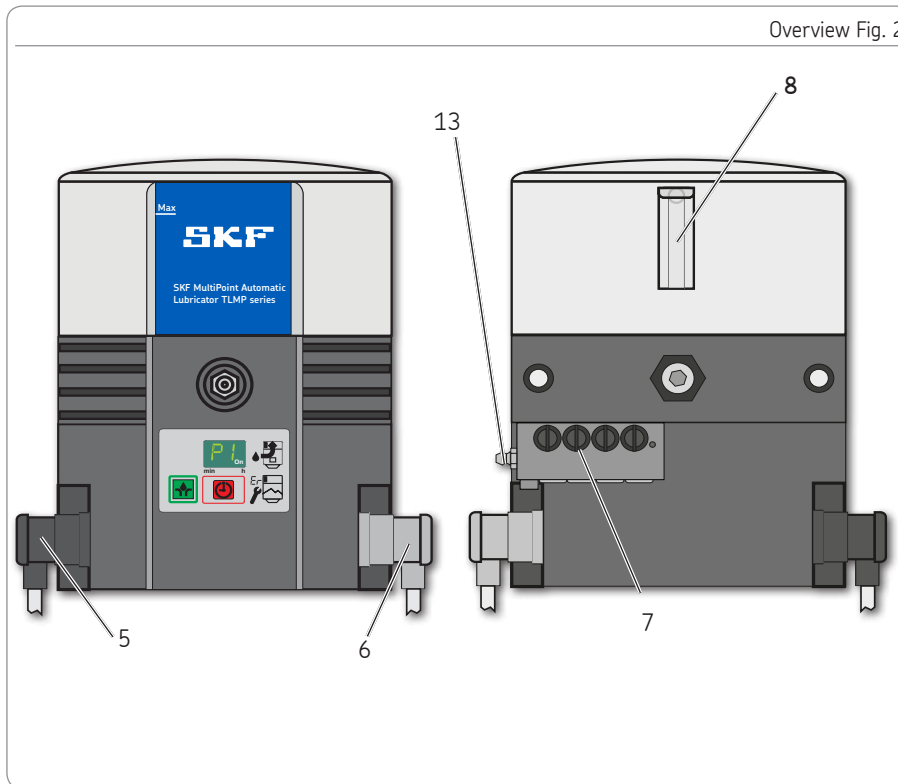

3.1 Changing the output volume of the SSV metering devices

About 0.2 cc of lubricant are supplied per stroke and outlet. Closing unneeded outlets with closure screws (7.2) increases the output of the next lower open outlet on the same side by the lubricant volume of the upper closed outlets. Maximum number of outlets that can be crossported internally is 4 with the TLMP 1008 and 9 with the TLMP 1018.

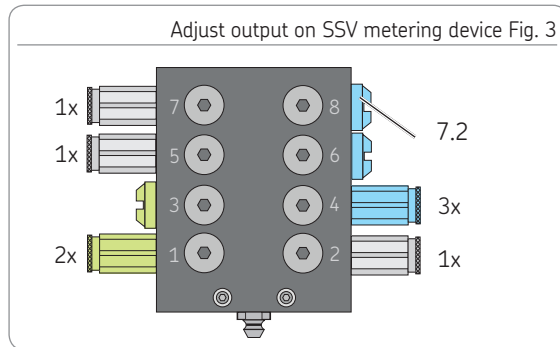

3.2 Return of unneeded lubricant to the pump

Return is realized internally:

for even numbers of outlets

- by closing outlet 2

for odd numbers of outlets

- by closing outlets 2 and 1

Feed lines are connected to the outlets with the highest numbers. The outlets with the lowest numbers are used for returning the lubricant.

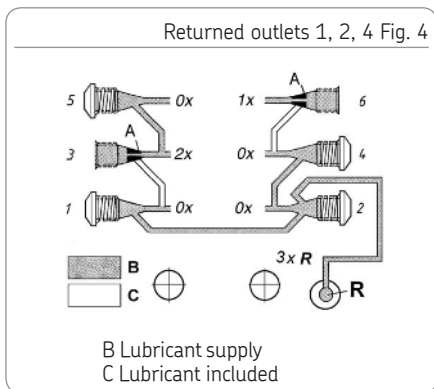

3.3 Membrane keypad

The membrane keypad (3) with display serves to:

- display operation states and error codes
- trigger an additional lubrication
- display and change parameters (programming)

All functions - except from the display of error codes - are available during the pump's pause time only.

Pump adjustments are made via the green adjustment key (3.3) and the red switch key (3.2) and are shown on the display (3.1).

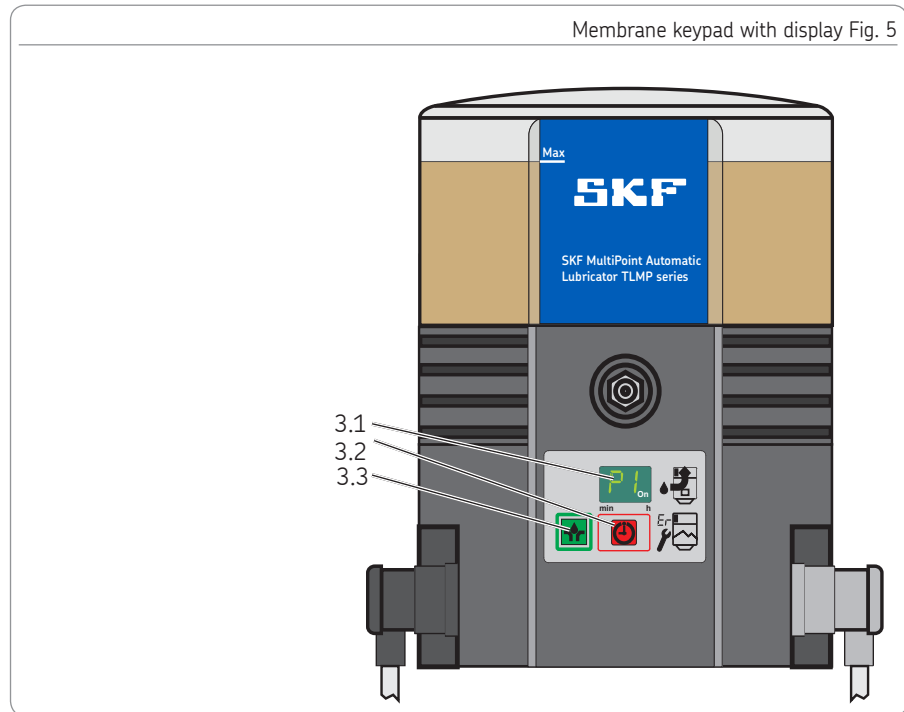

3.4 Displays in the display mode

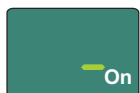

min h

Ready for operation

The pump is in the pause mode. There are no fault indications pending.



min h

Pump is on

The pump is in the operating mode. There are no fault indications pending.

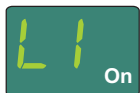

min h

Pre-low-level signal

The pump is in the operating mode. There is little lubricant available. The display alternates with "pump is on".

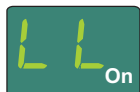

min h

Low level indication

Lubricant lacks. The pump terminates the current lubrication cycle. It can be restarted only after refilling the reservoir.



min h

Fault signal Er

An unspecified error is pending.



min h

Fault signal EP

A fault of the membrane keypad or the display is pending.

3.5 Displays in the programming mode



min h

Programming step P1

In this step the hourly data of the pause time is set..



min h

Programming step P2

In this step the minute value of the pause time is set.

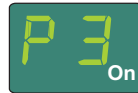

min h

Programming step P3

In this step the number of metering device cycles per operating cycle is set.



min h

Programming step P4

In this step the type of output signal is set.
nc = normally closed contact
no = normally open contact

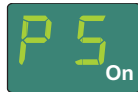

min h

Programming step P5

In this step it is determined whether a differentiation is made between a fault signal or a low-level signal.

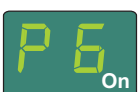

min h

Programming step P6

In this step it is set how the pump will start when being switched on.
SP = Start with pause time
SO = Start with lubrication time



End of programming
Programming has been completed. To adopt the values set the programming has to be confirmed with the green key 3.3 (see Fig. 13) within 30 seconds.



Normally closed contact
Output signal is preset as normally closed contact. Programming step P4



Normally open contact
Output signal is preset as normally open contact. Programming step P4



Fault - low-level signal
No differentiation between fault and low-level signal. Programming step P5



Output signal programmed as normally open contact
Intermittent low-level signal, functional faults as permanent signal (ON). Programming step P5

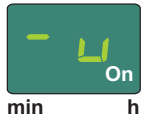

Output signal programmed as normally closed contact
Intermittent low-level signal, functional faults as permanent signal (OFF). Programming step P5

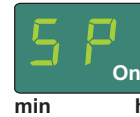

Start stage SP
When being switched on the pump starts with a pause time. Programming step P6

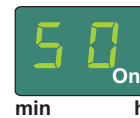

Start stage S0
When being switched on the pump starts with the lubrication time. Programming step P6



Remaining pause time
Consists of 3 consecutive displays that change in a two second interval.
Display 1

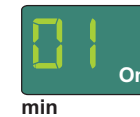

Display 2
Shows the remaining pause time in hours.



Display 3
Shows the remaining pause time in minutes.

Example: 0110. Remaining pause time
1 hour and 10 minutes.



min h

AC
Shows the number of automatically triggered operating cycles. Counter value 0-9999 (continuous). The display consists of 3 subsequent displays alternating in a two second interval.

Display 1



min h

Display 2
Shows the values in thousands and hundreds.



min h

Display 3
Shows the values in tens and units.

Example: 0625 = 625 automatically triggered operating cycles.



min h

UC
Shows the number of manually triggered additional lubrication cycles. Counter value 0-9999 (continuous). The display consists of 3 subsequent displays alternating in a two second interval.

Display 1



min h

Display 2
Shows the values in thousands and hundreds.



min h

Display 3
Shows the values in tens and units.

Example: 0110 = 110 manually triggered additional lubrication cycles.

4. Technical data

4.1 General technical data

Pump variant	24 V DC	120 V AC 60 Hz	230 V AC 50 Hz
Admissible operating temperature	-25 °C to 70 °C		
Operating pressure	120 bar max.		
Installation position	vertical (max. deviation ± 5 °)		
Lubrication points	max. 18		
sound pressure level	< 70 dB (A)		
Reservoir size	1 litre		
Filling	via hydraulic lubrication fitting R 1/4		
Weight of empty pump	approx. 6 kg		
Lubricants ²⁾	Lubricating greases NLGI II and NLGI III ¹⁾ / fluid greases NLGI 00, 000		
Output of pump element ²⁾	approx. 0.2 ccm (per stroke)	approx. 1.0 ccm (per minute)	
Output of metering device	approx. 0.2 ccm (per cycle)		
Maximum pump run time	30 minutes		

¹⁾ NLGI III lubricants may be supplied under certain operating conditions only. Therefore the lubricant's supply characteristics has to be clarified with SKF in advance.

²⁾ Observe the references given in chapter 4.6 and 4.7.

	Temperature [°C]:	-25 °C	-20 °C	+25 °C
024 V DC	Speed [rpm]	5.3 - 6.0	6.2 - 7.3	7.3 - 8.3
120 V AC	Speed [rpm]	5.9-6,9	8.3	8.5 - 9.0
230 V AC	Speed [rpm]	2.5 - 5, 6	6.5 - 6.8	6.9 - 7.1

The indicated rotational speeds depend on counterpressure and temperature. In principle the following applies:
The higher the counterpressure and the lower the temperature, the lower is the rotational speed.

4.2 Electrics

Pump variant	24 V DC	120 V AC 60 Hz	230 V AC 50 Hz
Power supply with square plug (left side)	yes	yes	yes
Tolerance of input voltage	-20 / + 30 %	±10 %	±10 %
Current input (maximum)	≤ 1 A	≤ 1 A	≤ 0.5 A
Types of protection	PELV		
Inputs	protected against reverse polarity, short circuit proof, non-isolated		
Fault signals with square plug (right side)	yes	yes	yes
Protective and disconnecting device required for isolation	yes	yes	yes
Switching voltage	48 V AC / DC	48 V AC / DC	48 V AC / DC
IP protection class of bayonet plug	65	65	65
AC fault relay for low level signal and fault signals	230 V AC	230 V AC	230 V AC
maximum switched current	5 A	5 A	5 A
DC fault relay for low level signal and fault signals	24 V DC	24 V DC	24 V DC
maximum switched current	5 A	5 A	5 A
Residual ripple (DIN 41755)	±5 %	±5 %	±5 %
# IP 67 only for square plugs with prefabricated cable			

4.3 Factory settings of pumps

Programming step/ value	Factory setting	Setting range
P1 Pause time in hours	6 hours	0-59 hours
P2 Pause time in minutes	0 minutes	0-59 minutes
P3 Metering device cycles per operating cycle	1 cycle	V DC pumps 1-5 cycles V AC pumps 1-3 cycles#
P4 Signal output fault relay	no	NO contact / NC contact
P5 Differentiation of low-level signal and fault signal	--	-- (no differentiation) -U (output signal as nc contact) -Π (output signal as no contact)
P6 Start stage	SP	[SP] Pump starts with pause time [SO] Pump starts with lubrication time
Maximum runtime	30 minutes	not modifiable
Maximum adjustable pause time = 59 hours 59 minutes Minimum adjustable pause time V DC pump = 4 minutes Minimum adjustable pause time V AC pump = 20 minutes # For the AC versions adhere to the following value in order to avoid pump failure due to exceeding the max. runtime: maximum of 3 cycles		

4.4 Tightening torques

Adhere to the following tightening torques when installing or repairing the pump.

Pump with base plate, machine, or vehicle	18 Nm ± 1 Nm
Metering device with QLS pump	9 Nm ± 1 Nm
Pump element with pump housing	25 Nm ± 2 Nm
Outlet fitting on metering device	
screw-in type	17 Nm ± 1 Nm
plug-in type	12 Nm ± 1 Nm
Indicator pin fitting	18 Nm ± 1 Nm
Closure screw (outlet)	15 Nm ± 1 Nm
Closure screw (piston)	18 Nm ± 1 Nm
Coupling nut on outlet fitting	
Plastic tube	10 Nm ± 1 Nm
Steel tube	11 Nm ± 1 Nm
Cover of pump housing	1.6 Nm + 0.8 Nm
Reservoir with pump housing	7 Nm + 1 Nm

4.5 Necessary lubricant consistencies in case of intermittent low level signal

The following lubricant consistencies have to be complied with in order to ensure correct functioning of the intermittent low level indication.

NLGI class	Temperature	NLGI class	Temperature
0.5	≤ + 20 °C	1.5	≤ + 50 °C
1.0	≤ + 40 °C	2.0	≤ + 70 °C

* maximum admissible pump operating temperature



The intermittent low-level indication is not suitable for lubricants ≤ NLGI class 0.

4.6 Useable reservoir volume

The useable reservoir volume mainly depends on the NLGI consistency class and the operating temperature of the lubricant to be used. In case of high consistency and low operating temperature normally more lubricant sticks to the inner surfaces of the reservoir/ pump and is thus no more available for being dispensed.

Useable reservoir volume
1-litre reservoir with low level indication (XL)

Lubricants with relatively high consistency ⁴⁾ approx. 0.5 to 0.8 litres

Lubricants with relatively low consistency ⁵⁾ approx. 0.6 to 0.9 litres

⁴⁾ Lubricant consistencies of NLGI 2 lubricants at + 20 °C up to the maximum admissible lubricant consistency.

⁵⁾ Lubricant consistencies of NLGI-000 lubricants at + 70 °C up to lubricant consistencies of NLGI-1.5 lubricants at + 20 °C.

4.7 Lubricant requirement for priming of an empty pump

To prime an empty pump up to the MAX marking of the reservoir, the following lubricant quantities are required.

Reservoir size	Quantity	
1 litre	1.75 litres ± 0.15	When using lubricants of a relatively low consistency in pumps subjected to strong vibrations or tilting motions (e.g. construction and agricultural machinery), make sure to maintain a level that is about 25 mm below the MAX marking of the reservoir. This prevents lubricant from entering the reservoir vent. In case of very strong vibrations this value must be increased, for low vibrations it can be reduced. Changing the filling level by 10 mm corresponds to a volume change of about 0.2 litres.

5. Delivery, returns, and storage

5.1 Delivery

After receipt of the shipment, check the shipment for damage and completeness according to the shipping documents. Immediately report any transport damages to the forwarding agent.

Keep the packaging material until any discrepancies are resolved. During in-house transport ensure safe handling.

5.2 Returns

Clean all parts and pack them properly (i.e. following the regulations of the recipient country) before returning them.

Protect the product against mechanical influences such as impacts. There are no restrictions for land, sea or air transport. Mark returns on the packaging as follows.



5.3 Storage



Before application inspect the products with regard to possible damages occurred during their storage. This particularly applies for parts made out of plastic and rubber (embrittlement) as well as for components primed with lubricant (ageing).

SKF products are subject to the following storage conditions:

- the admissible storage temperature range corresponds to that of the operating temperature (see Technical data)
- dry, dust- and vibration-free in closed premises
- no corrosive, aggressive materials at the place of storage (e. g. UV rays, ozone)
- protected against pests and animals
- in the original product packaging
- shielded from nearby sources of heat and coldness

- in case of high temperature fluctuations or high humidity take adequate measures (e. g. heater) to prevent the formation of condensation water.

6. Assembly

6.1 General information

Only qualified technical personnel may install, operate, maintain, and repair the products described in these Instructions. Qualified technical personnel are persons who have been trained, assigned, and instructed by the operator of the final product, into which the described product shall be integrated.

Such persons are familiar with the relevant standards, rules, accident prevention regulations, and operating conditions as a result of their training, experience, and instruction. They are qualified to carry out the required activities and in doing so recognize and avoid any potential hazards.

Before assembling the product, the packaging material as well as possible transport locking devices must be removed. Keep the packaging material until any discrepancies are resolved.



NOTE

Technical data (see chapter 4).

6.2 Attachment

Protect the product against humidity and vibration and install it in an easily accessible position to ensure all other installations can be carried out without any problem. For indications on the maximum admissible ambient temperature see the technical data. During assembly and particularly during any drilling work always pay attention to the following:

- Other units must not be damaged by the assembly.
- The product must not be installed within the range of moving parts.
- The product must be installed at an adequate distance from sources of heat and coldness.
- Adhere to safety distances and legal prescriptions on assembly and prevention of accidents.

		CAUTION
	<p>Electric shock Make sure to disconnect the product from the power supply before carrying out works on any part of it. Connection of the 24 V DC pump must be provided by a safe galvanic isolation (PELV) always.</p>	

6.3 Minimum assembly dimensions

Ensure sufficient space for maintenance work or for a possible disassembly of the product by leaving a free space of at least 50 mm into each direction in addition to the stated dimensions.

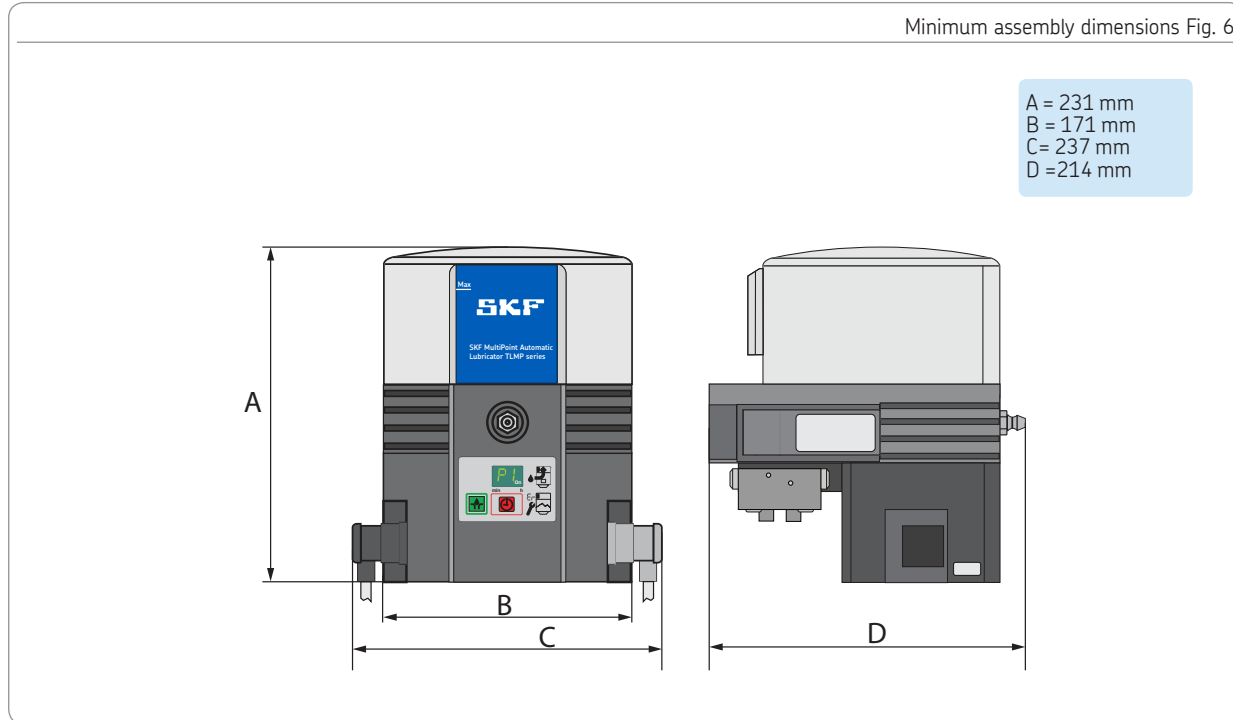

6.4 Connecting dimensions

The pump is fastened on the two mounting bores. Fastening is done by means of the fastening material included in the scope of delivery.

2 x M8 screw

2 x M8 nut (self-locking)

2 x washer

Tightening torque = 18 Nm

Connecting dimensions Fig. 7

Connection dimensions

E = hole distance 146 mm

F = height 110 mm

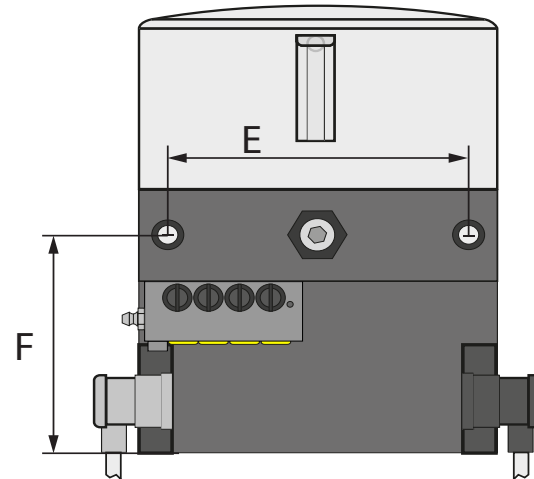

6.5 Electrical connection

Electrical connections must be done in such way that no forces are transferred to the product (tension-free connection). For electrical connection proceed as follows:

Square plug

- Use adequate cable to configure square plug without cable. For connection of the cable, see wiring diagram on square plug or corresponding wiring diagram in these Instructions (see chapter 12).
- Remove protective caps from the electrical connections of the pump.
- Place plugs with sealing onto connections and fasten them by means of a screw.

NOTE

Observe the electrical characteristics (see chapter 4).

6.6 Priming of pumps

To prime the pump proceed as follows:

- Position bin below the pump to collect leaking lubricant.
- Screw out the yellow transport locks (7.1) from the metering device outlets.
- Close unneeded outlets of the metering device with closure screws.
- Place filling connection of grease gun or transfer pump onto filler fitting (2).
- Fill reservoir with lubricant until the MAX marking (Fig. 19). To do so, observe the notes contained in chapter 4.8.
- Press key (3.1) to let the pump run until lubricant leaks from the open outlets of the metering device.
- Switch the pump off.
- Mount the primed lubricant lines to the open outlets of the metering device and then connect them to the lubrication points.

- Remove lubricant collecting bin and dispose of leaked lubricant in an ecologically sound manner.

The pump is now ready for operation with the factory settings or can be adapted accordingly by changing the relevant parameters (programming).

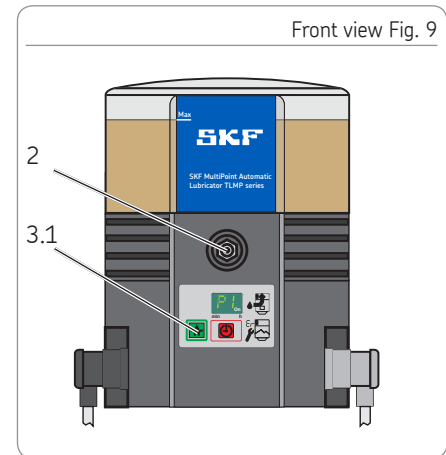
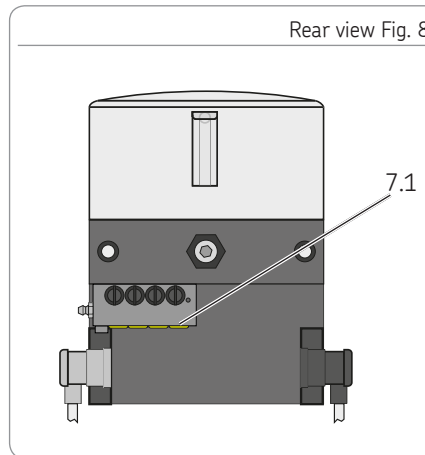

6.7 Programming

To program TLMP 1008 pumps proceed according to the following programming scheme.

Simultaneously press key 3.2 and key 3.3 for about 4 seconds to access the first programming step P1. After releasing the keys the adjusted value will be displayed. Change the value of the programming step by pressing key 3.3.

Confirm adjusted value within 30 seconds by pressing key 3.2. Otherwise the value will be lost.

Programming is continued with programming step P2. After confirming the last step P6 the programming is completed.

Programming steps

P1 Setting of the pause time in hours

P2 Setting of the pause time in minutes

P3 Setting of the metering device cycles

P4 Setting of the output signal on the monitoring relay

P5 Setting of the differentiation between fault and low-level signal.

P6 Setting of the start stage

A = Programming step

B = Possible value

C = Change value by pressing the key

D = Possible new value

E = Confirm adjusted value within 30 seconds by pressing key 3.2 and continue with the next programming step. Confirm and finish the programming by pressing key 3.3 after the last programming step.

Notes related to the programming

Settings can be done in one direction only (+)
Fast forward by holding down key 3.3.

Programming scheme Fig. 10

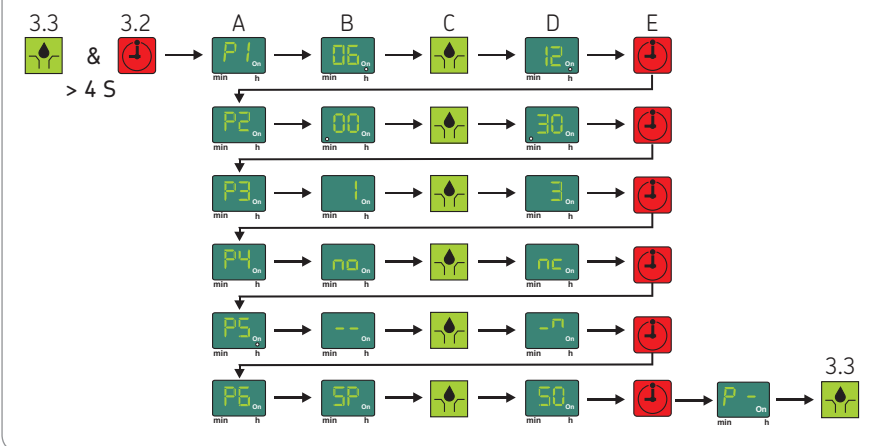

7. Start-up

7.1 General information

Start-up of the fully and correctly mounted TLMP pump is effected via the machine contact or the driving switch. If "EP", "Er" is displayed after switching the pump on, a fault is pending.

NOTE

If the power supply is interrupted within 1 minute from switching the pump on, after switching the pump on again the pause time starts from the beginning.

If the power supply is interrupted after 1 minute from switching the pump on, after switching the pump on again the pause time will continue from where it had been interrupted.

7.2 Triggering an additional lubrication cycle

To trigger an additional lubrication cycle proceed as follows:

- Press the reset key (3.3) for > 2 seconds.
- The pump starts a lubrication cycle. At the same time the pause time already lapsed is reset.
- In the display there appears the symbol "Pump on".

NOTE

The duration of the additional lubrication corresponds to the preset number of metering device cycles per lubrication cycle.

Trigger an additional lubrication Fig. 11

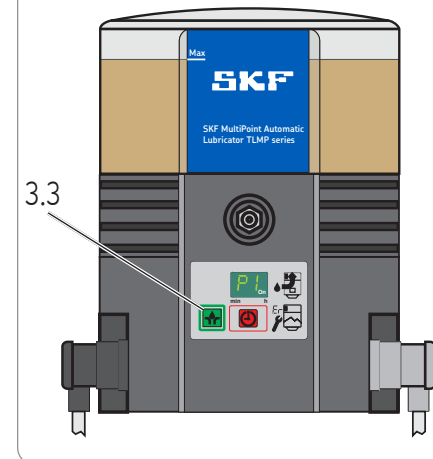

8. Operation, shutdown and disposal

8.1 General information

After correct electrical connection and filling with lubricant the pump is ready for operation.

Start-up respectively shutdown is effected by switching the superior machine or vehicle on or off.

NOTICE

Damage to the pump

Make sure that no dirt enters the reservoir during the filling procedure.

Overfilling of the reservoir

Consider lubricant expansion by increased temperature.

8.2 Filling the reservoir during operation

Filling via filler fitting

- Connect the filling adapter to the filler fitting (5) and fill reservoir with lubricant until shortly below MAX marking. To do so, observe the notes contained in chapter 4.8.

8.3 Temporary shutdown

Temporarily shut the system down by disconnecting it from the power supply.

8.4 Shutdown and disposal

In case of final shutdown follow the applicable rules and regulations on disposal. The product can also be returned to the manufacturer for proper disposal, in which case the customer is responsible for reimbursing the costs incurred. The parts are recyclable.

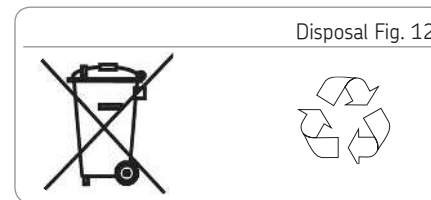

9. Maintenance, cleaning and repair

9.1 General information

Liability is excluded for any damage or faults arising from inappropriate maintenance, repair or cleaning.

9.2 Maintenance

- There are no parts to be maintained by the customer.

9.3 Cleaning

- Thorough cleaning of all outer surfaces. Do not use aggressive cleaning agents. Interior cleaning is required only in case of accidental use of contaminated lubricant.

9.4 Replacement of the membrane keypad

To replace the membrane keypad proceed as follows:

- Switch the pump off and disconnect it from the electrical grid. Loosen fitting (5.1) on plug (A1) and remove plug.
- Unscrew the cover of the pump housing on the four screws (11) and carefully remove the cover downwards.

- Carefully lift the control printed circuit board (10) from bottom to top out of the bracket in the cover until the blue plug (10.1) of the control printed circuit board is easily accessible.
 - Remove blue plug from the control printed circuit board.
 - Carefully loosen the adhesive membrane keypad from the housing and remove it together with the connection cable.
 - Guide the connection cable of the new membrane keypad from the front through the opening for the membrane keypad in the housing and plug it onto the corresponding port of the control printed circuit board. Ensure that the plug is oriented correctly.
 - Carefully insert control printed circuit board in the bracket.
 - Stick new membrane keypad onto housing.
 - Mount cover of pump housing with four new microencapsulated screws (11).
- Tightening torque = 1.6 Nm + 0.8 Nm.**
- Remount plug A1 to connect the pump to the power grid.

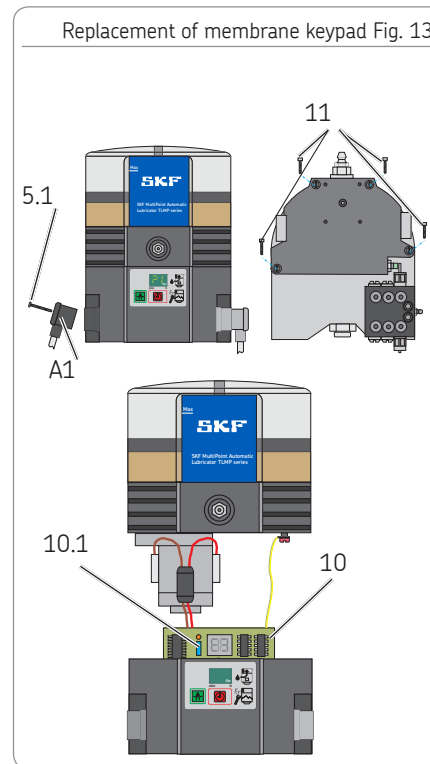

10. Troubleshooting

Fault messages

Fault message on the display	Meaning	Remedy
Fault signal LI	<ul style="list-style-type: none"> Pre-warning empty There is little lubricant available. The display alternates with "pump is on". 	<ul style="list-style-type: none"> Fill reservoir
Fault signal LL	<ul style="list-style-type: none"> Low-level indication No lubricant available anymore. The pump still completes the current lubrication cycle. A restart can take place only after refilling the reservoir. 	<ul style="list-style-type: none"> Fill reservoir
Fault signal EP	<ul style="list-style-type: none"> Fault of the membrane keypad or fault of the display 	<ul style="list-style-type: none"> Replace membrane keypad Replace control printed circuit board
Fault signal Er	<ul style="list-style-type: none"> An unspecified error is pending. 	<ul style="list-style-type: none"> Replace the control printed circuit board. If necessary, replace the entire pump.

If the fault cannot be determined and remedied, please contact our Customer Service.

Mechanical faults on pumps

Fault	Possible cause/ recognizability of fault	Remedy
Air pockets in the lubricant or lubrication system	<ul style="list-style-type: none"> Visual check for bubbles in the lubricant 	<ul style="list-style-type: none"> Vent lubricant (if required, trigger several additional lubrication cycles)
Reservoir vent is clogged	<ul style="list-style-type: none"> Visually check whether there is lubricant in the reservoir vent. 	<ul style="list-style-type: none"> Remove lubricant from the reservoir venting device
Suction bore of pump element is clogged.	<ul style="list-style-type: none"> After disassembling the pump element 	<ul style="list-style-type: none"> Disassemble and clean the pump elements.
Piston of pump element is worn Defective check valve in the pump element	<ul style="list-style-type: none"> Too low pressurization 	<ul style="list-style-type: none"> Replace pump element.
Defective pressure relief valve Blockade on a lubrication point or in the SSV metering device	<ul style="list-style-type: none"> Lubricant leaking from the pressure reducing valve 	<ul style="list-style-type: none"> Replace pressure relief valve. Check the lubrication point and the SSV metering device and remedy fault, if necessary.

If the fault cannot be determined and remedied, please contact our Customer Service.

Mechanical faults on pumps

Fault	Possible cause/ recognizability of fault	Remedy
Lubricant volume on one or more lubrication points deviates from projected values	<ul style="list-style-type: none"> ○ Wrong setting of pause time or number of metering device cycles ○ Wrong cross-porting of outlets on the SSV metering device 	<ul style="list-style-type: none"> ○ Check and, if necessary, correct pause time settings and metering device cycles ○ Check and, if necessary, correct cross-porting of outlets
Pump is permanently on/ Pump does not switch off	<ul style="list-style-type: none"> ○ Indicator pin on metering device does not move within switching distance of proximity switch or indicator pin is not positioned centrally in front of proximity switch 	<ul style="list-style-type: none"> ○ Check position and distance of indicator pin (distance < 0.5 mm) and correct, if necessary

If the fault cannot be determined and remedied, please contact our Customer Service.

Electrical faults

Fault	Possible cause/ recognizability of fault	Remedy
Power supply to pump interrupted	<ul style="list-style-type: none"> ○ Recognizable - pump display is off. Fault in the superior machine/vehicle. ○ External fuse defective ○ Plug (A1) of power supply not mounted to pump correctly 	<ul style="list-style-type: none"> ○ See documentation of the superior machine or vehicle ○ Check the external fuse and replace, if necessary. ○ Check correct fastening of plug (A1) and correct, if necessary.
Power supply interrupted from control pcb to motor	<ul style="list-style-type: none"> ○ Pump display is off 	<ul style="list-style-type: none"> ○ Check power supply from the control pcb to the motor and correct, if necessary.
Motor does not run despite circulating segmented display	<ul style="list-style-type: none"> ○ Defective motor connection 	<ul style="list-style-type: none"> ○ Check motor connection following the corresponding circuit diagram.
Defective motor	<ul style="list-style-type: none"> ○ After triggering an additional lubrication pump does not run despite external power supply and control pcb 	<ul style="list-style-type: none"> ○ Replace pump

If the fault cannot be determined and remedied, please contact our Customer Service.

11. Spare parts

The spare parts may be used exclusively for replacement of identical defective parts.
Modifications (except from metering screws) with spare parts on existing products are not allowed.

11.1 SSV metering devices

Designation	Qty.	Part number
SSV metering device 8 K rear-mounted	1	TLMP 1-D8
SSV metering device 18 K rear-mounted	1	TLMP 1-D18

11.2 Kit of seals

Designation	Qty.	Part number
Kit of seals		TLMP 1-S

11.3 Foam filter

Designation	Qty.	Part number
Foam filter	1	TLMP 1-F

11.4 Tubing and connectors

Designation	Qty.	Part number
20 meter tubing	1	TLMP 1-T
Connection kit (20 m tubing, 7 closure plugs, 8 tube fittings, 8 lubricant outlets)	1	TLMP 1-TC

11.5 Membrane keypad

Designation	Qty.	Part number
Adhesive membrane keypad	1	TLMP 1-K

Fig. 11.1

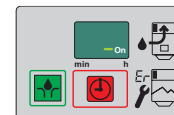

11.6 Pump element

Designation	Qty.	Part number
Pump element D6	1	TLMP 1-P

Fig. 11.2

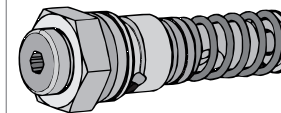

11.7 Adapter M22 x 1.5

Designation	Qty.	Part number
Adapter M22 x 1.5	1	TLMP 1-A

Fig. 11.3

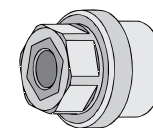

11.8 Indicator pin fitting

Designation	Qty.	Part number
Closure screw for indicator pin	1	TLMP 1-I

Fig. 11.4



11.9 Reservoir

Designation	Qty.	Part number
Transparent 1-l reservoir with sealing and labels	1	TLMP 1-R

11.10 Housing cover replacement kit

Designation	Qty.	Part number
Housing cover replacement kit	1	TLMP 1-H

A replacement kit consists of: Housing cover including membrane, membrane keypad, housing sealing, plug for feed line including protective cap, corresponding number of microencapsulated housing screws and required adhesive labels.

Fig. 11.5

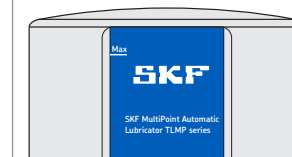
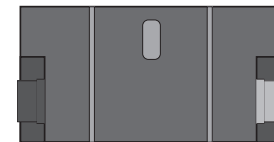

Fig. 11.6



11.11 V DC motors

Designation	Qty.	Part number
Pump motor 24 V DC	1	TLMP 1-M24

11.12 motor connections VDC

Designation	Qty.	Part number
Motor connection V DC	1	TLMP 1-W

11.13 Electrical connections

Designation	Qty.	Part number
Square plug with connection socket (black) with 10 m cable	1	TLMP 1-S

11.14 Control printed circuit board replacement kit

	Voltage		Jumper	Qty.	Part number
	120	VAC	NO	1	TLMP 1-C120
	230	VAC	NO	1	TLMP 1-C230
	24	VDC	NO	1	TLMP 1-C24

A replacement kit consists of: Control printed circuit board, housing sealing, corresponding number of microencapsulated housing screws and service instructions for replacement of control printed circuit board,

Fig. 11.7

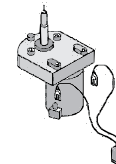

Fig. 11.8

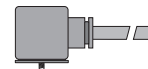
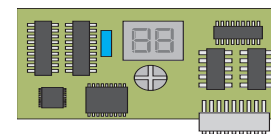

Fig. 11.9



12. Circuit diagrams

12.1 Legend

Cable colours following IEC60757							
Abbreviation	Colour	Abbreviation	Colour	Abbreviation	Colour	Abbreviation	Colour
BK	black	GN	green	WH	white	PK	pink
BN	brown	YE	yellow	OG	orange	TQ	turquoise
BU	blue	RD	red	VT	violet		

Components			
Abbreviation	Meaning	Abbreviation	Meaning
X1	Plug for connection A1	LL	Low level indication
X2	Plug for connection A2	LLV	Low level indication with pre-warning
X6	Plug for connection of low level indication	PCB	Control pcb
X9	Plug for connection of external SSV metering device	mP	Microprocessor
CS	Cycle switch	mKP	Display
L	Suppressor throttle	MC	Machine contact
FE	Ferrite core	IS	Drive switch/ ignition
PE	Protective earth	M	Motor
F1 F2	External fuse		

12.2 Core assignment of the connection plugs

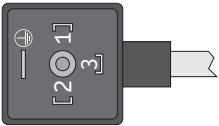
Core assignment of connection A1 / X1			
Pin 1	Pin 2	Pin 3	PE
Y	Y	Y	Y
RD	BN	BK	GN/YE
Square plug EN 175301-803 / DIN 43650 / A			
			

12.3 Circuit diagram 24 V DC, with square plug

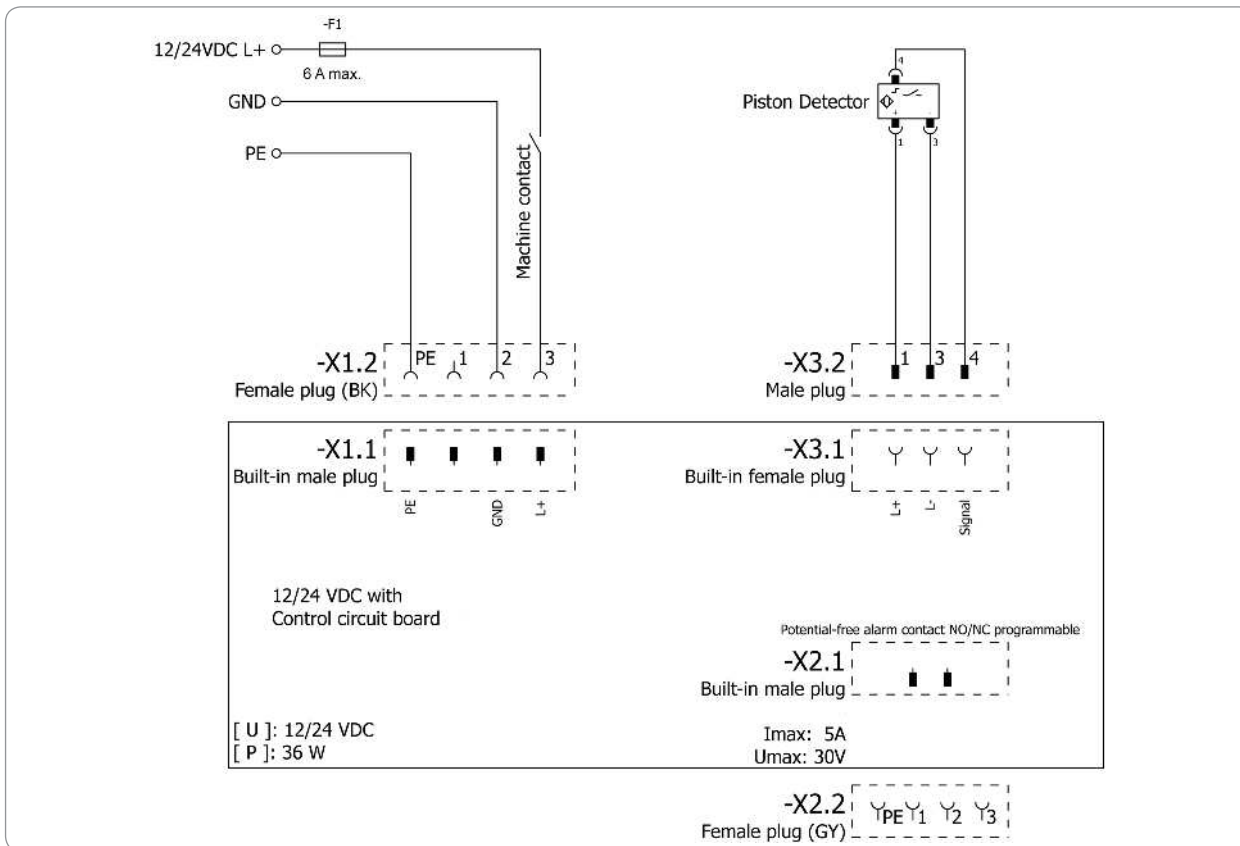

12.4 Circuit diagram 120 V AC, with square plug

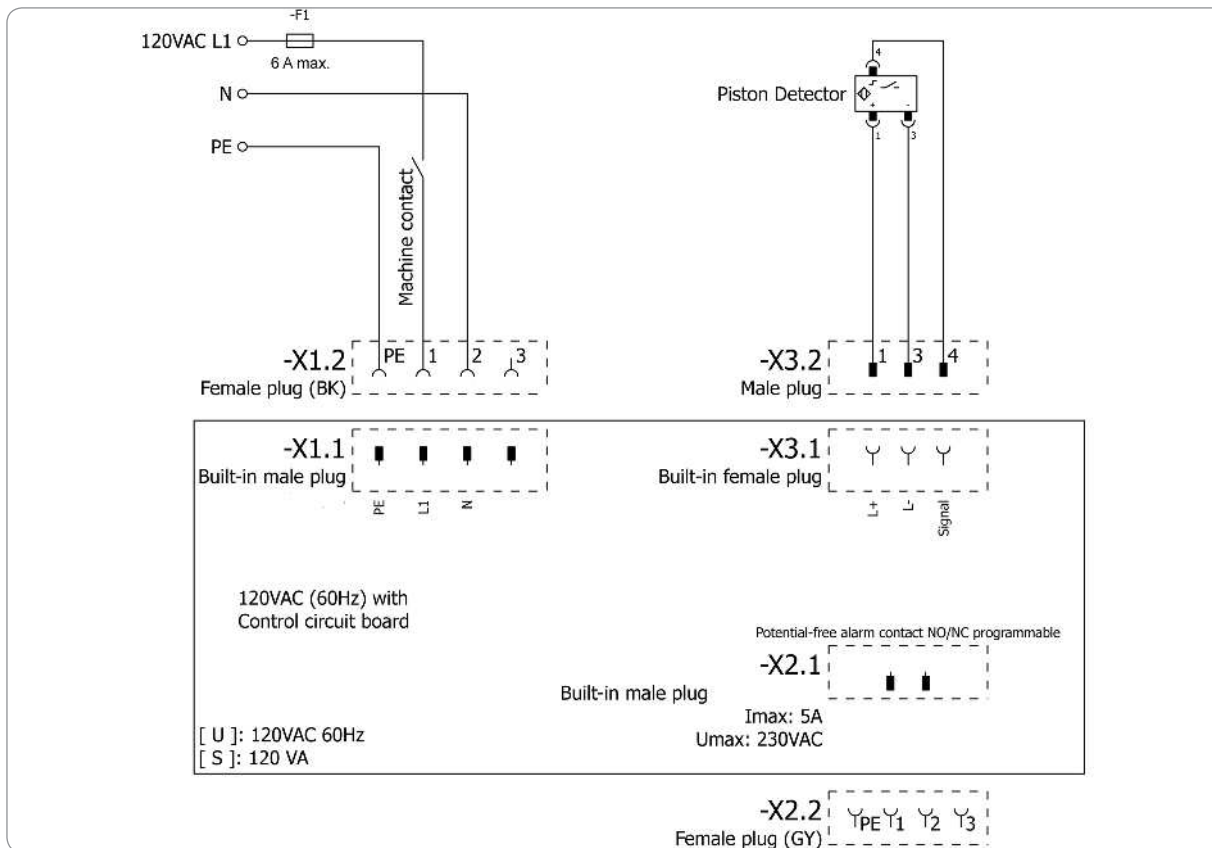

12.5 Circuit diagram 230 V AC, with square plug

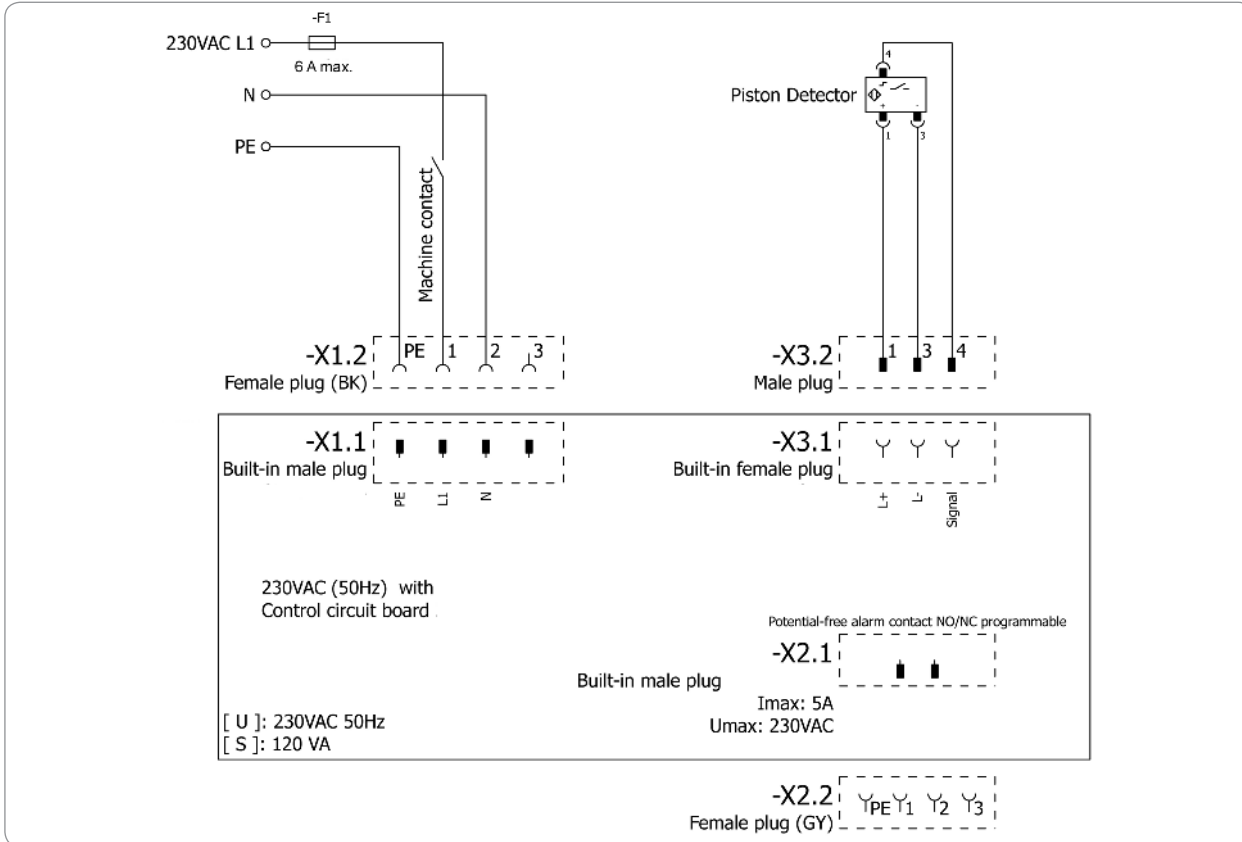

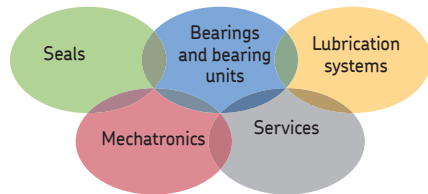

The Power of Knowledge Engineering

Drawing on five areas of competence and application-specific expertise amassed over more than 100 years, SKF brings innovative solutions to OEMs and production facilities in every major industry worldwide.

These five areas of competence include bearings and bearing units, seals, lubrication systems, mechatronics (combining mechanics and electronics into intelligent systems), and a wide range of services, from 3-D computer modelling to advanced condition monitoring and reliability and assessment management systems. A global presence provides SKF customers uniform quality standards and worldwide product availability.

SKF Maintenance Products
Kelvinbaan 16
3439 MT Nieuwegein
The Netherlands
www.mapro.skf.com

MP5460EN
951-171-030-EN
Version 02
2017/01/02

Important information on product usage

All products from SKF may be used only for their intended purpose as described in this brochure and any instructions.

Not all lubricants are suitable for use in centralized lubrication systems. SKF does offer an inspection service to test customer supplied lubricant to determine if it can be used in a centralized lubrication system.

SKF lubrication systems or their components are not approved for use with gases, liquefied gases, pressurized gases in solution and fluids with a vapor pressure exceeding normal atmospheric pressure (1013 mbar) by more than 0.5 bar at their maximum permissible temperature.

