

# INSTALLATION INSTRUCTIONS

## SLB-024 and SLM-024 Interface Brackets

SLB and SLM series Interface brackets are designed for use with Chief RPA, RPM, and Smart-Lift series projector mounts. See the specific installation instructions provided with the mount for additional installation information.

Unpack carton and verify kit contents. If any listed parts are missing, immediately contact a Chief Customer Service representative by calling 1-800-582-6480.



**WARNING: IMPROPER INSTALLATION CAN LEAD TO EQUIPMENT FALLING CAUSING SERIOUS PERSONAL INJURY AND DAMAGE TO EQUIPMENT! DO NOT substitute hardware. Use only hardware supplied by manufacturer!**

- |                             |  |
|-----------------------------|--|
| (1) Interface Bracket       | (4) Screw, Philips Pan Head, Machine, M4 x 20mm **** |
| (4) 10-24 Thumb Nuts **     | (4) Washer, Flat, M4                                 |
| (1) All-Points Security Kit | (4) 1/2" x .194" x 1/2" Round Spacer ****            |

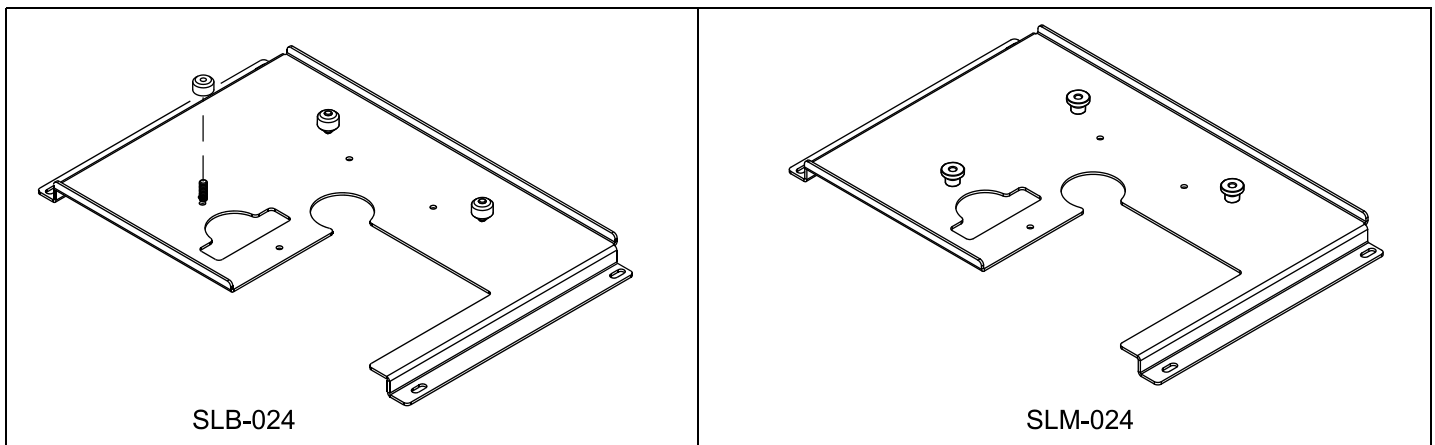

\*\*Only used when installing SLB Interface brackets.

\*\*\*\*Used when mounting surface of projector is recessed.

### Installation:



**WARNING: OVERTIGHTENING OF SCREWS CAN DAMAGE PARTS AND LEAD TO SERIOUS PERSONAL INJURY AND DAMAGE TO EQUIPMENT! DO NOT over tighten screws when installing Interface bracket.**

**NOTE:** Step 1 is only required when installing an SLB Interface bracket. If an SLM bracket is being installed proceed to step 2.

1. Screw four thumb screws onto four 10-24 x 5/8" Philips pan head screws. DO NOT fully tighten thumb screws at this time.
2. Turn projector upside down.
3. Place the four 1/2" spacers on the bottom of the projector over the four threaded mounting inserts.
4. Place the interface bracket onto the four spacers on the bottom of the projector, lining up the four threaded inserts in the bottom of the projector with the four mounting holes in the bracket.
5. Using the four M4 x 20mm mounting screws and washers, start them into the mounting holes by hand and secure all four fasteners at this time.

**NOTE:** Security screws can be substituted when mounting Interface bracket to projector by using the parts and installation instructions in the All-Points Security Kit.

CSAV, Inc., and its affiliated corporations and subsidiaries (collectively, "CSAV"), intend to make this manual accurate and complete. However, CSAV makes no claim that the information contained herein covers all details, conditions or variations, nor does it provide for every possible contingency in connection with the installation or use of this product. The information contained in this document is subject to change without notice or obligation of any kind. CSAV makes no representation of warranty, expressed or implied, regarding the information contained herein. CSAV assumes no responsibility for accuracy, completeness or sufficiency of the information contained in this document.

