

SMART Electric Height-Adjustable Floor Stand

FSE-410 (Model S410-1) and FSE-420 (Model S420-1)

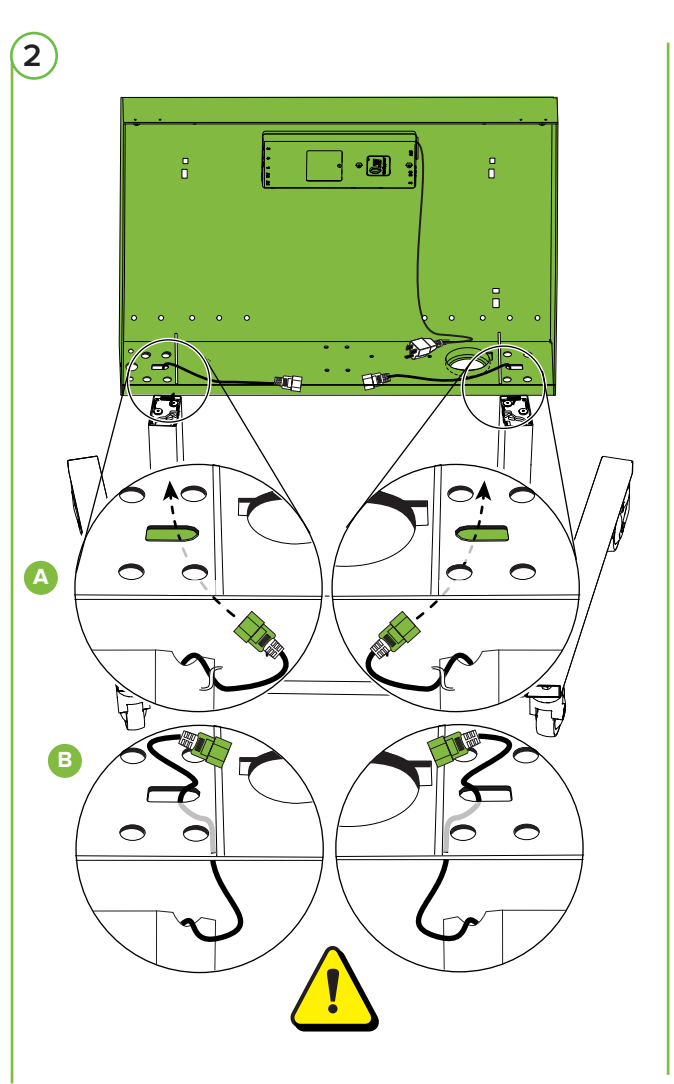

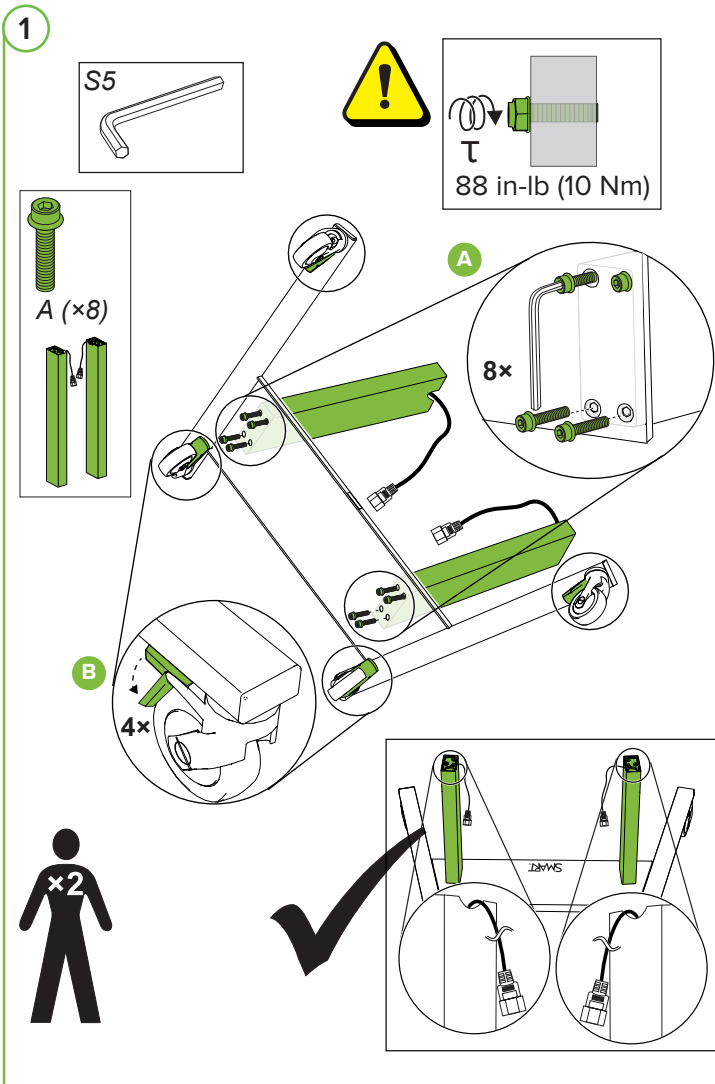
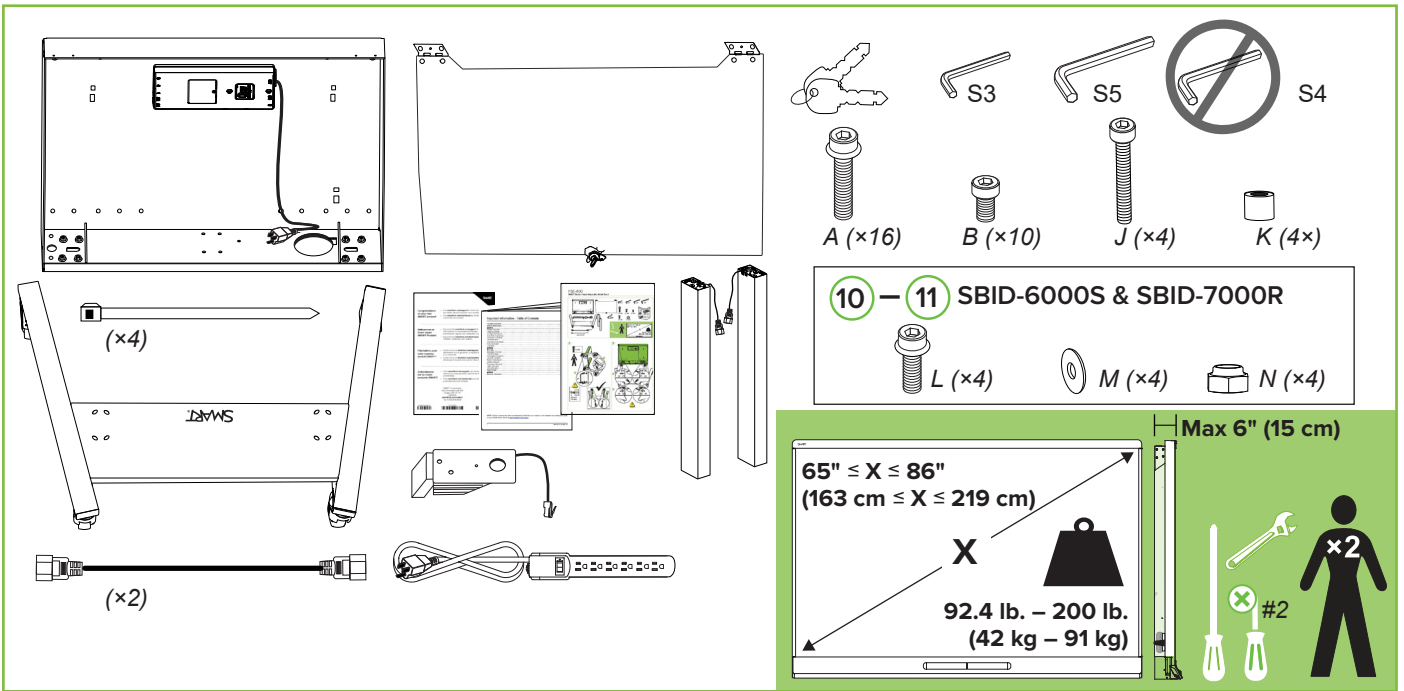
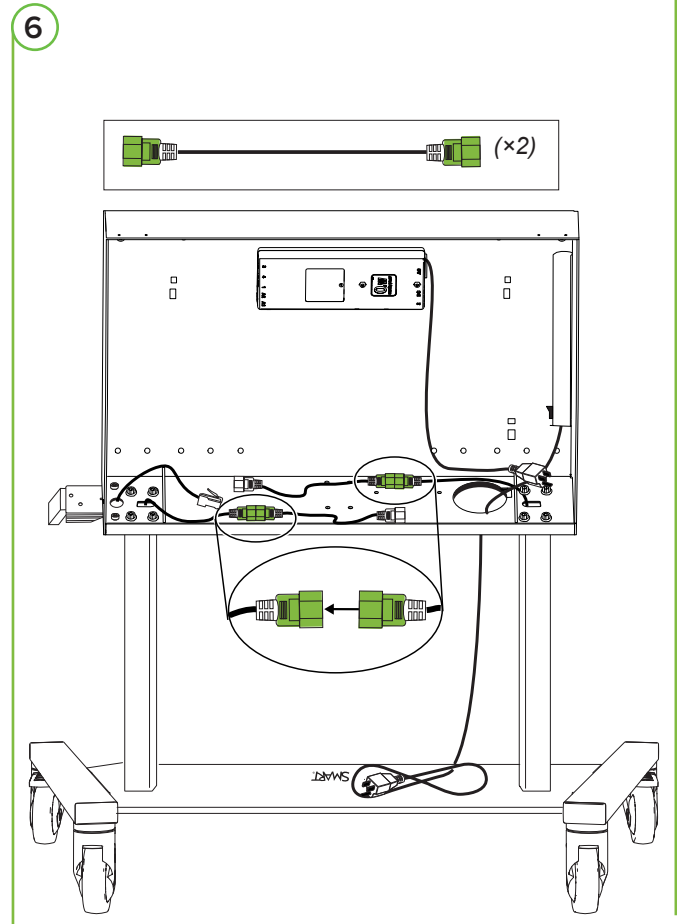
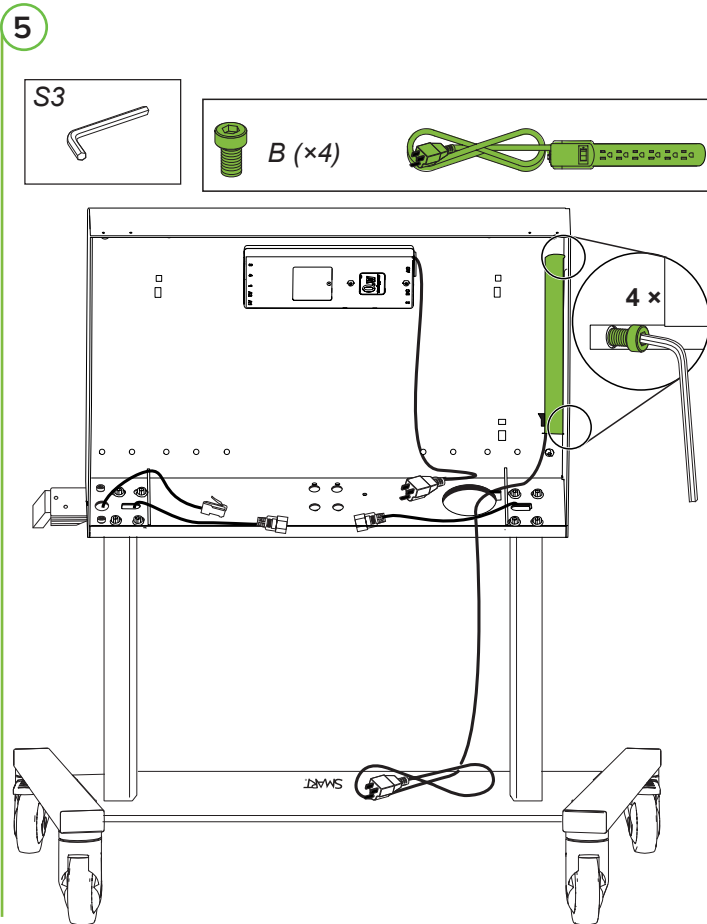
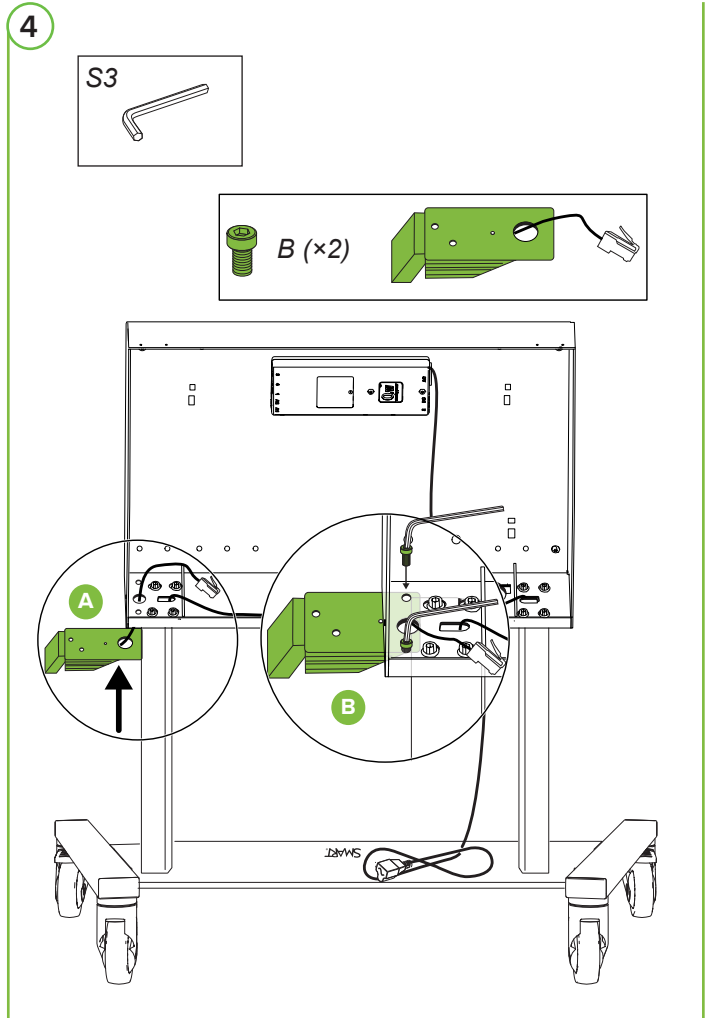
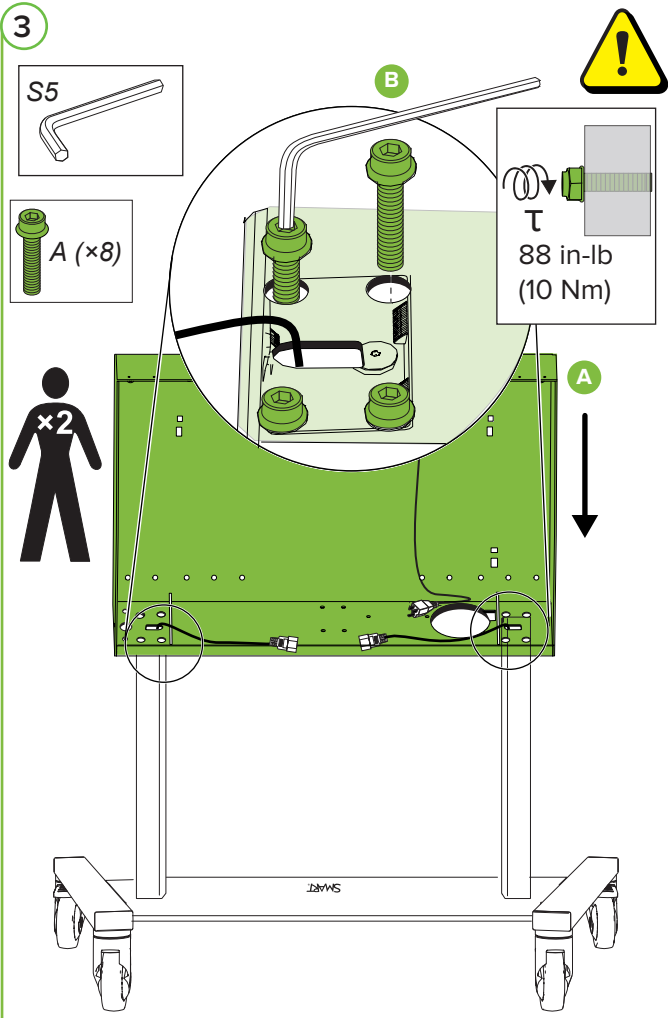

7

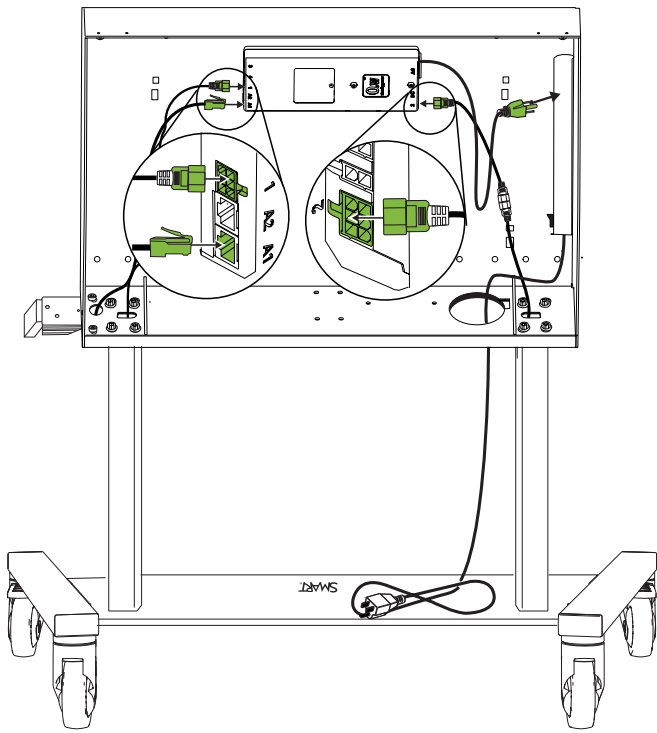

8

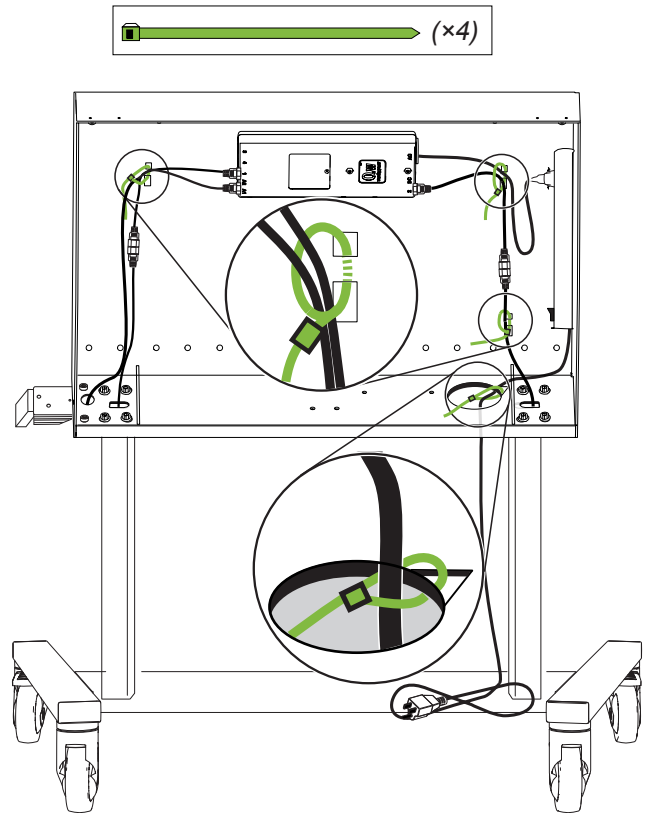

9

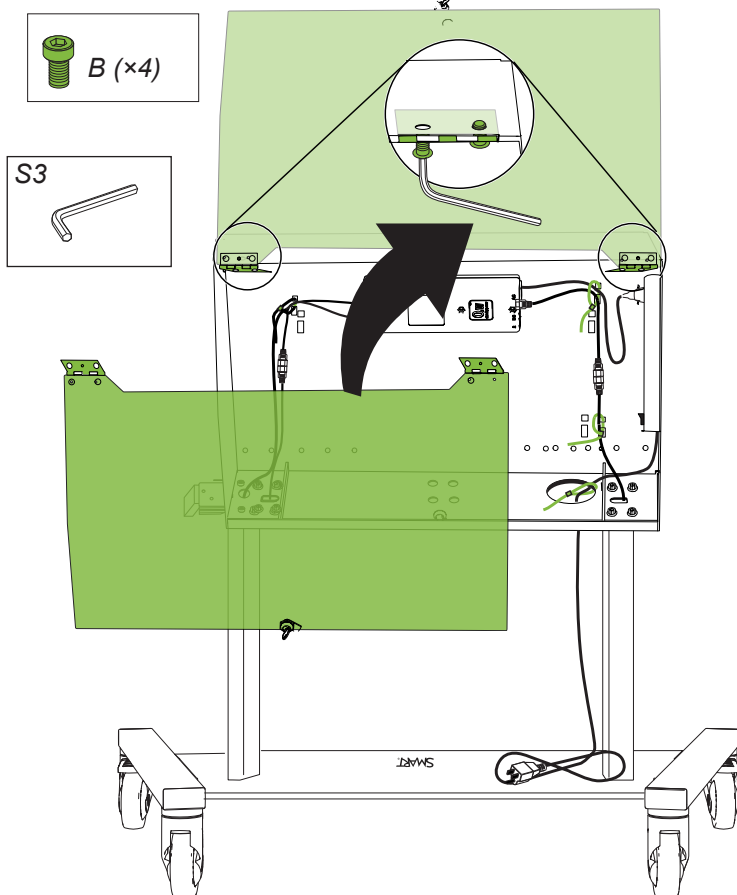

SBID-6000S → **10** — **13**
SBID-7000R

SBID-XXXX → **14** — **16**

10 SBID-6000S & SBID-7000R

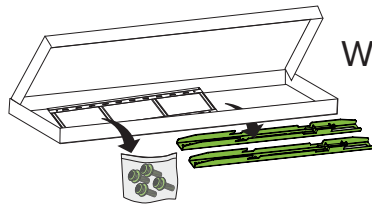

WM-SBID-200

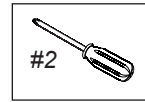

SBID-6000S

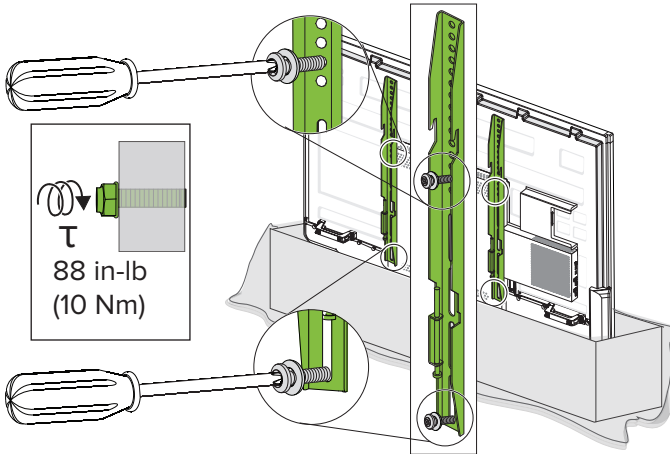

SBID-7000R

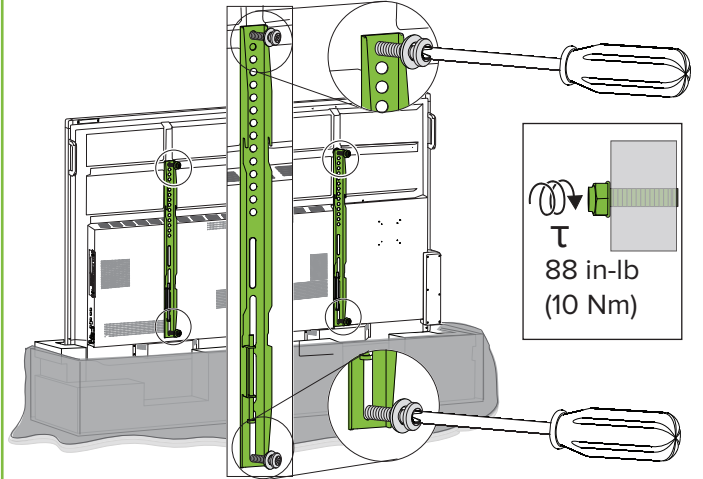

11

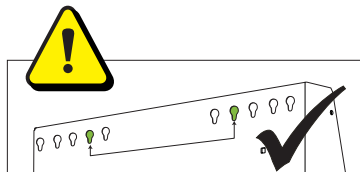
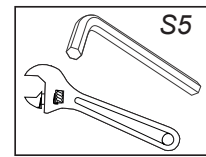
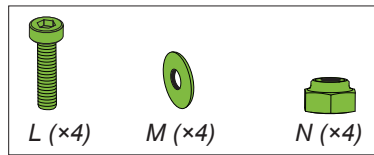
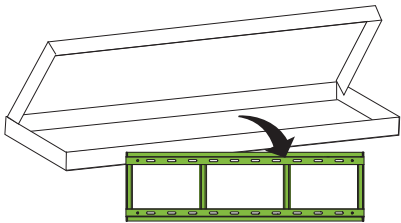

Use corresponding holes as shown.
Utilisez les trous correspondants
comme indiqué.

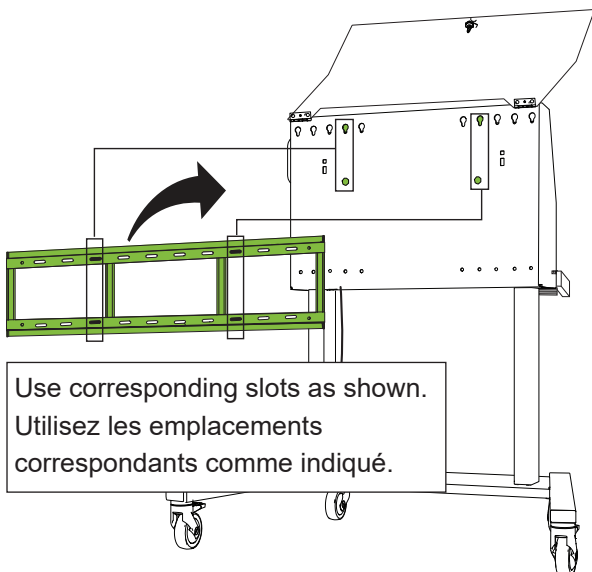

Use corresponding slots as shown.
Utilisez les emplacements
correspondants comme indiqué.

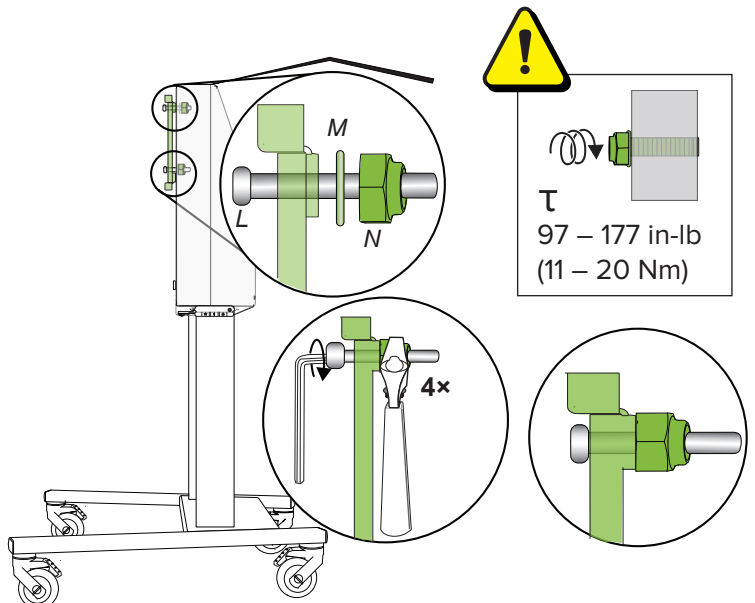

τ
97 - 177 in-lb
(11 - 20 Nm)

12

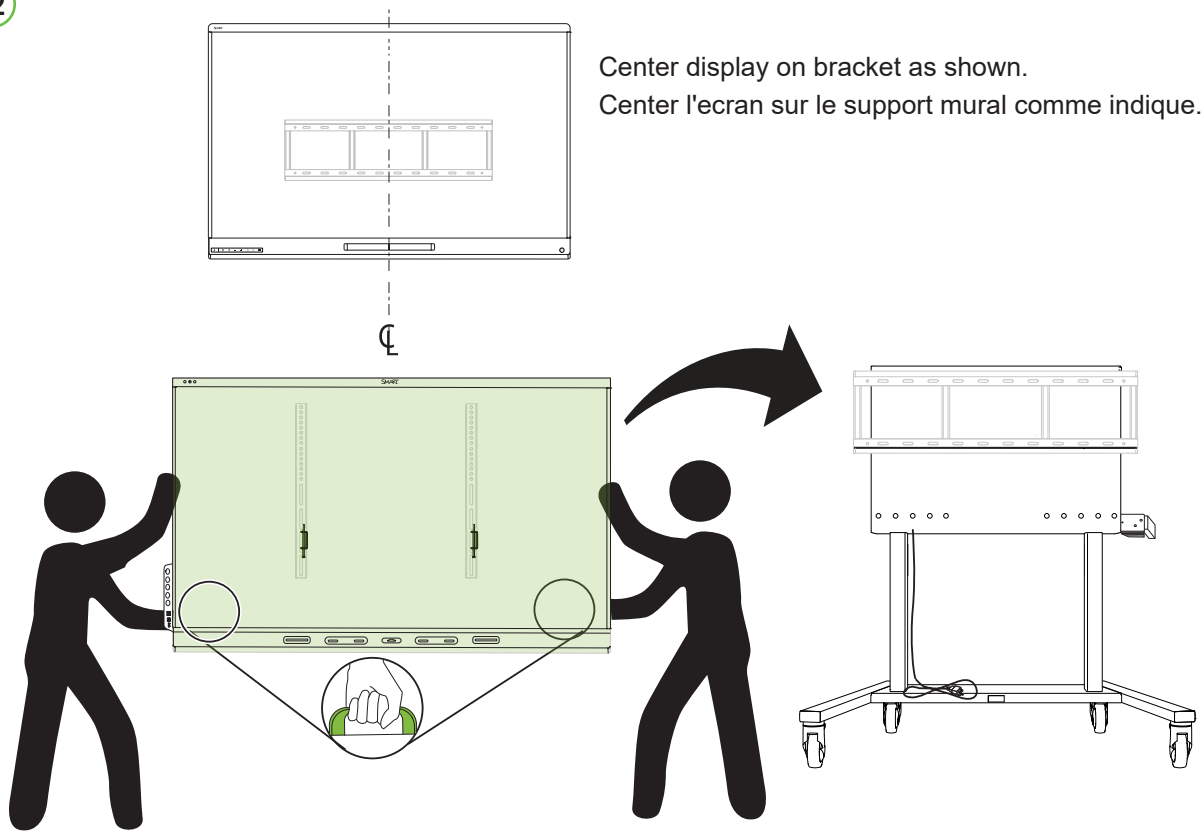

Center display on bracket as shown.
Center l'écran sur le support mural comme indiqué.

13

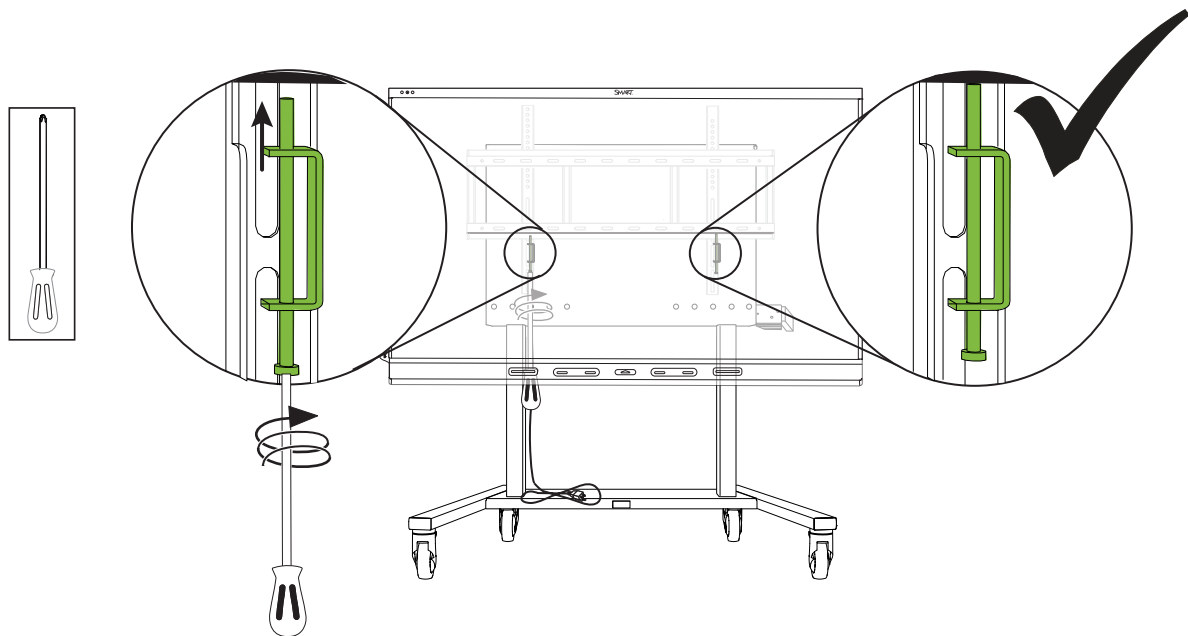

Secure the display to the wall plate by tightening the locking screws with a Phillips No. 2 screw driver until the screws contact the wall plate.

Fixez l'écran à la plaque murale en serrant les vis de verrouillage à l'aide d'un tournevis Phillips No. 2 jusqu'à ce que les vis touchent la plaque murale.

14

SBID-XXXX

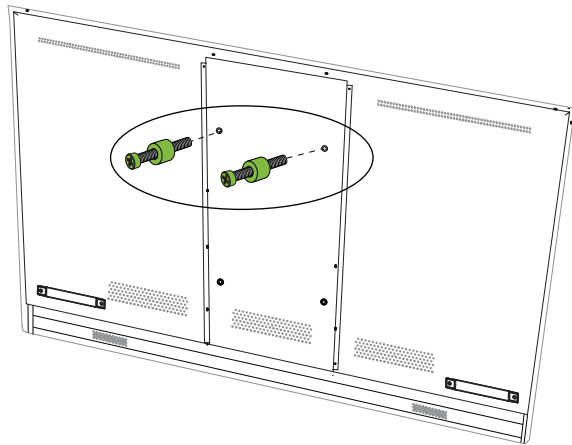
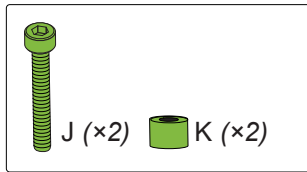
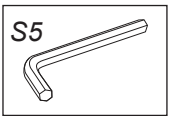

15

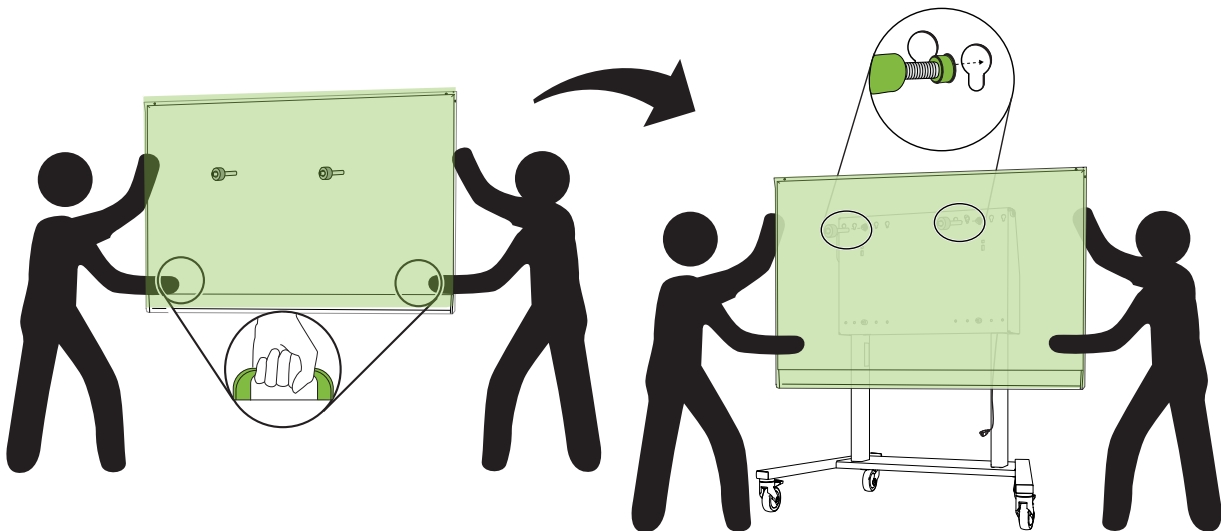
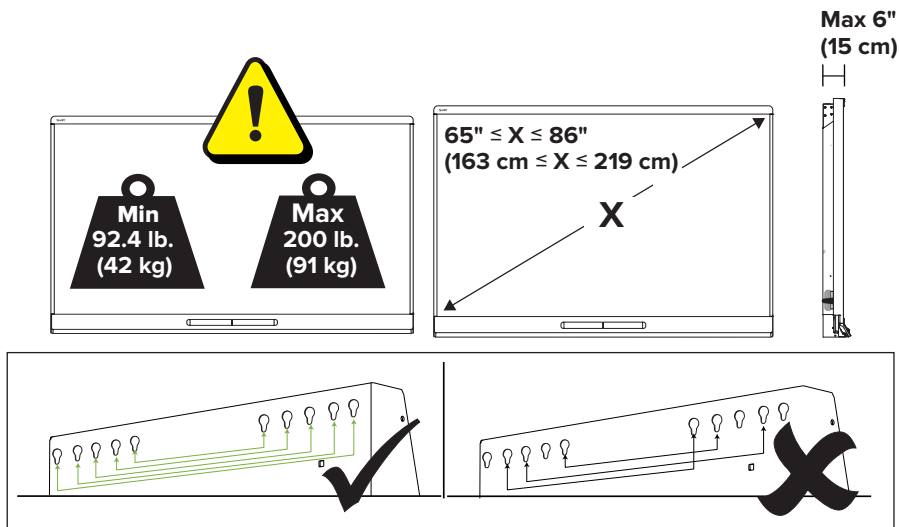

16

A

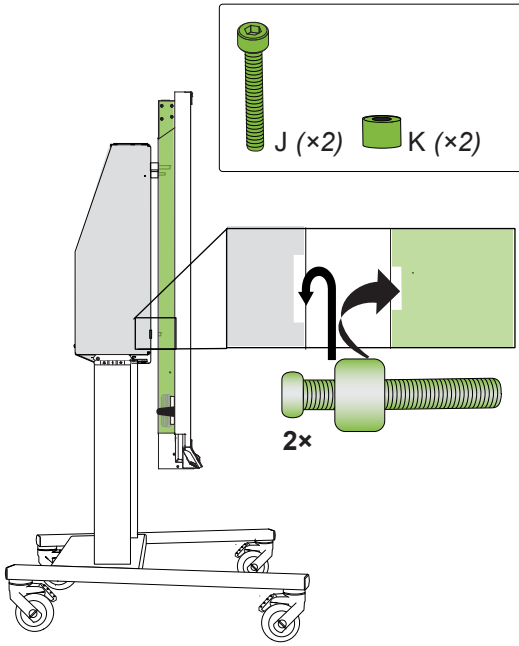

B

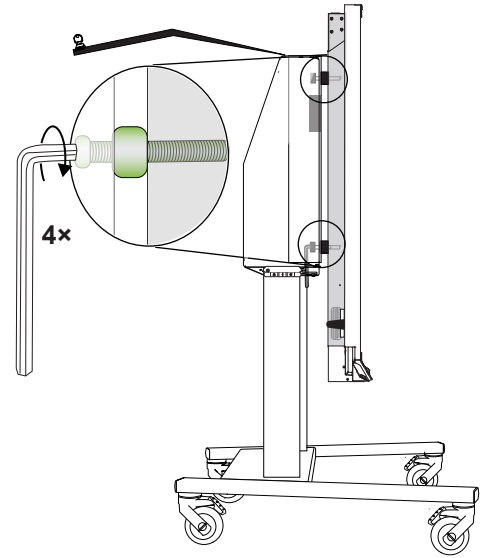
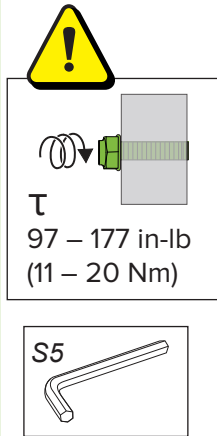

17

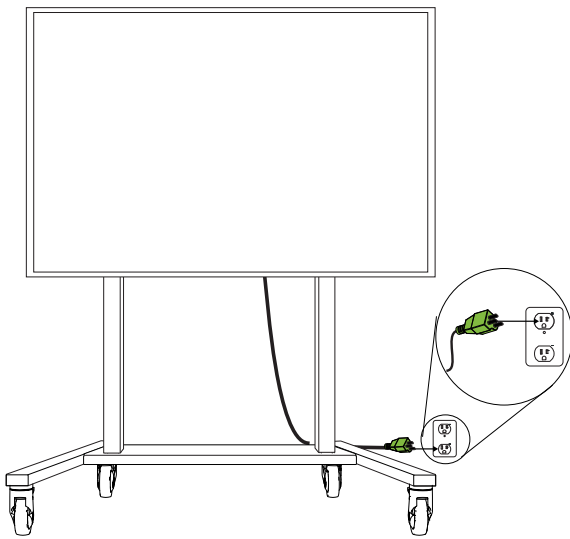

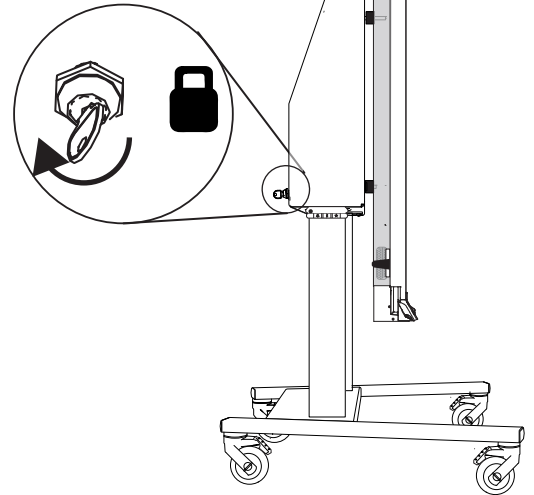
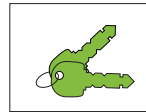

18

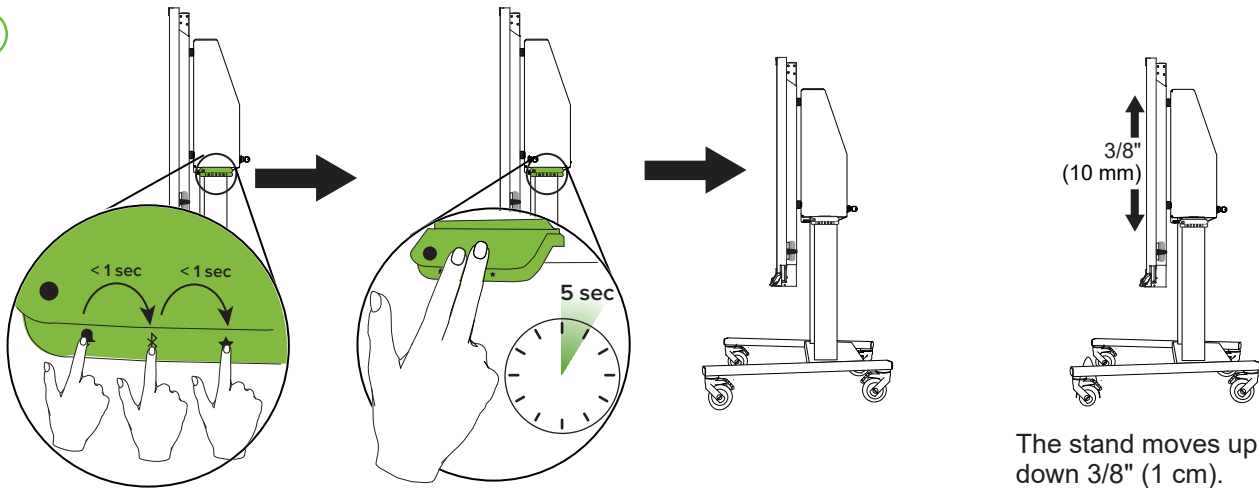

19



Press the , , and  buttons in sequence

Press and hold the control switch for 5 seconds.

The stand moves up and down 3/8" (10 mm).

The stand is ready for use or has been reset.



smarttech.com/fse400troubleshoot

Was this document helpful? smarttech.com/docfeedback/171620

WARNING

Risk of Electric Shock, Fire and Injury. Review the Assembly Instructions to confirm that the appropriate critical components and accessories are being used with this stand.

The power bar is a critical component: the supplied power bar must be a 6 outlet power bar, identified as Model TPL615B. This model number is molded into the cover on the bottom of the power bar. This is the only approved power bar for this unit.

The wall bracket, WM-SBID-200 (Model W200-1), is a critical component. It is required for use with the SBID-6000S and SBID-7000R series displays. This is the only approved mounting bracket for use with this unit.

AVERTISSEMENT

Risque de choc électrique, d'incendie et de blessure. Consultez les instructions de assemblage pour confirmer que les composants et accessoires critiques appropriés sont utilisés avec ce stand.

La barre d'alimentation est un composant critique: la barre d'alimentation fournie doit être une barre d'alimentation à 6 prises, identifiée comme le modèle TPL615B. Ce numéro de modèle est moulé dans le couvercle au bas de la barre d'alimentation. Il s'agit de la seule barre d'alimentation approuvée pour cet unité.

Le support mural WM-SBID-200 (modèle W200-1) est un composant critique. Il est nécessaire pour une utilisation avec les écrans des séries SBID-6000S et SBID-7000R. Il s'agit du seul support de montage approuvé à utiliser avec cet unité.

FCC

Suppliers Declaration of Conformity 47 CFR § 2.1077 Compliance Information • Unique Identifier: S410-1 or S420-1

Responsible Party – U.S. Contact Information: **SMART Technologies Inc.** 2401 Fourth Ave., Suite 300, Seattle, WA 98121 • Mail to: compliance@smarttech.com

FCC Compliance statement

This device complies with part 15 of the FCC Rules. Operation is subject to the following two conditions: (1) This device may not cause harmful interference, and (2) this device must accept any interference received, including interference that may cause undesired operation.

Innovation, Science and Economic Development Canada (ISED)

This device complies with ICES-003 of the ISED rules. Operation is subject to the following two conditions:

- (1) This device may not cause harmful interference, and
- (2) this device must accept any interference received, including interference that may cause undesired operation.

Cet appareil est conforme à la norme ISED NBM-003 pour les appareils radio agréés. Son fonctionnement est sujet aux deux conditions suivantes:

- (1) le dispositif ne doit pas produire de brouillage préjudiciable, et
- (2) ce dispositif doit accepter tout brouillage reçu, y compris un brouillage susceptible de provoquer un fonctionnement indésirable.



support.smarttech.com/support
support.smarttech.com/contact-support

SMART[®]