



Primary injection testing system

User's Guide



Raptor

Reference: KAXVMV02

Published: 11 April 2016

Version: 3

Quality is the core of the business activity of EuroSMC, S.A., aimed at fully satisfying customer needs and expectations.

LIMITATION OF LIABILITY

EuroSMC, S.A. does not recognise any contractual link derived from the information set forth in this document, including the product features and technical data. The user is solely liable for the consequences of applying the product referenced in this document. EuroSMC, S.A. explicitly declines any liability for accidents or undesired results that could be derived directly or indirectly from the incorrect or incomplete drafting of this document. The partial or total reproduction of this document is not permitted without the prior written authorisation of EuroSMC, S.A., which reserves the right to modify this document and the products hereof without prior notice.

LIMITED WARRANTY

This product is guaranteed against material and manufacturing defects of the product itself for a period of 12 months as from the registration date of the product. If this registration does not occur after 30 days as from the shipping date, the shipping date will be considered the start of the warranty period.

Our commitment is limited to the substitution and/or replacement of those materials and components that are proved to be defective during the warranty period.

This warranty does not cover defects caused by the operator outside the product specifications established in this Instruction Manual.

EuroSMC, S.A. may not be held liable for any direct or indirect damage accidentally caused by the product.

TRANSPORT CONDITIONS

This warranty covers transport expenses, exclusively according to the following conditions and the indicated limitations:

1. If the equipment shows a failure that requires transport to the factory during the period of TWO MONTHS after the entry into force of the Warranty, the transport expenses will be covered entirely by EuroSMC S.A.
2. If the equipment shows a failure that requires transport to the factory as from TWO MONTHS and up to the end of the first year, the equipment will be sent to the factory at the customer's cost, and the return transport will be paid for by EuroSMC S.A.
3. The customer may not, in any event, send the equipment to the factory without a Service Ticket issued by EuroSMC S.A. Otherwise, EuroSMC S.A. will not pay for any cost referring to transport.
4. If the failure shown by the equipment (after being diagnosed at the factory) is not covered under the terms of the Warranty, EuroSMC S.A. will not pay for any cost referring to transport.

HOW TO ACTIVATE THIS WARRANTY

It is essential that you register your product at our web site as soon as possible. This registration is absolutely necessary so that your warranty enters into force appropriately.

Therefore, visit our web site (www.smcint.com), select the Support option and click on the Register Product button displayed there. Answer the questions in the Product Registration questionnaire and click on Send.

If the product is not registered, EuroSMC S.A. reserves the right whether or not to grant the warranty during the period of one year.

¿NECESITA REPARAR O CALIBRAR?

NEED SERVICE OR CALIBRATION?



¡NO ENVÍE SU EQUIPO SIN SERVICE TICKET!

REQUEST A SERVICE TICKET FROM US FIRST!

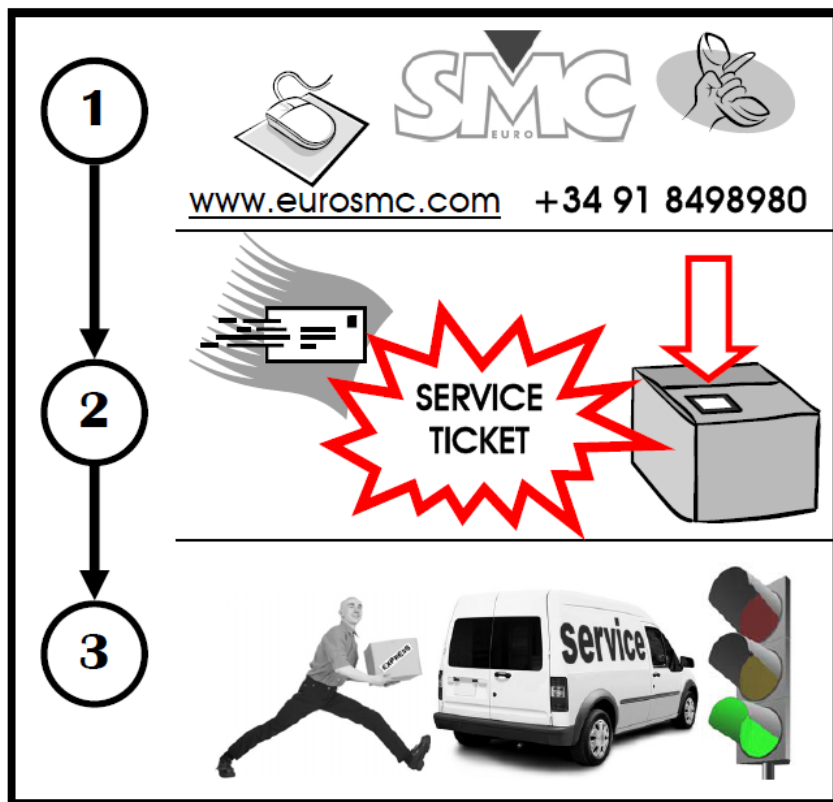

TABLE OF CONTENTS

LIMITED WARRANTY	3
TRANSPORT CONDITIONS	3
HOW TO ACTIVATE THIS WARRANTY	3
TABLE OF CONTENTS	5
DECLARATION OF CONFORMITY	9
Manufacturer	9
Declaration of Conformity	9
Standards applied	9
Standards applied to Raptor HV	10
ELEMENTS COMPRISED IN THE SYSTEM	11
SAFE USE OF THE EQUIPMENT	13
Symbols used	13
Dangerous Situations	13
Hazardous situations for the Raptor system	14
INTRODUCTION	15
LOCATION OF ELEMENTS	17
Raptor MS (Control panel)	19
Raptor MS (Expansion panel)	20
Raptor SL (Control panel)	21
Raptor HH	22
Raptor HV (Control panel)	23
HOW TO CONNECT THE SYSTEM	24
Positioning of the equipment	24
Make the connections	25
TURNING ON THE SYSTEM	27
AN INITIAL VIEW OF THE CONSOLE	29
The status LEDs	29
Main touch screen	30
Help and alarms scroll bar	30

Measurements zone.....	31
Injection zone.....	33
MAKING THE FIRST INJECTION.....	35
AVAILABLE MEASUREMENTS.....	41
Internal measurements.....	41
Hardware measurements.....	42
Calculated Measurements.....	45
Functions related to measurement.....	46
OBTAINING THE TEST REPORTS.....	47
Concept of Report and Test.....	47
How to use the Reports and Tests.....	47
Using the RaptorSync programme (for PC with Windows).....	48
Windows XP operating systems.....	48
Windows Vista, Windows 7 and Windows 8 operating systems.....	51
Information and reports of the device.....	52
Local database.....	53
OTHER POSSIBLE INJECTIONS.....	55
ANTICIPATING THE CURRENT THAT WILL BE OBTAINED.....	56
Data entry.....	56
The results of the calculation.....	58
MANAGEMENT OF THE PRE-DESIGNED TEMPLATES.....	59
Template management.....	59
Description of Factory templates.....	60
General.....	60
Circuit breaker.....	61
Overcurrent relay.....	62
Current Transformer (CT).....	63
Rogowski CT.....	66
Low Power CT.....	68
AC Resistance.....	68
Ground grid.....	70
CT Burden.....	72
Voltage-based CT.....	74
Volt. Transformer (VT).....	76
VT Burden.....	78
Short-circuited PT.....	80
PT ratio.....	83

Polarity test	85
Dielectric strength with HV.....	86
Voltage transformer with HV.....	88
No-load PT with HV	89
PT short circuit with HV	91
SPECIAL FUNCTIONS	93
Recloser.....	93
CT Magnetisation.....	95
Pulse train	98
Pulse ramp.	99
HV Magnetisation.....	100
Step and touch voltage.	101
NEED MORE CURRENT, VOLTAGE OR POWER.....	107
Maximum output voltage of the system.....	107
The power supply.....	107
Number of turns.....	108
Number of Raptor SL units	108
Minimum load impedance.....	108
Distance to burden.....	108
Parasitic inductance.....	109
CONFIGURATION AND MAINTENANCE	111
Configuration	111
Change language.....	111
Change date and time of the system	111
Adjust Internet connection properties (TCP/IP)	111
VNC Server	112
Safety adjustment in Raptor HVunit	114
Keep the system up-to-date.....	114
Update control program of the Raptor HH/M.	115
Update firmware of the Raptor MS/Raptor HV units.	116
Consult the Firmware versions of the Raptor SL unit.	116
Consult serial numbers of the units that make up the system.	116
Adjust the Hardware meters	116
Adjust the Raptor HV Hardware meters.....	118
Factory settings	119
PROBLEMS THAT MIGHT ARISE	120
SPECIFICATIONS.....	121
Raptor MS.....	121

Raptor SL.....	123
Raptor HH	124
Raptor HV.....	125
Ordering Information.....	127
APPENDICES	129
RAPTOR PT ACCESSORY.....	129
General description.....	129
Applications.....	129
Usage.....	129
Setting up the Raptor PT accessory.....	131
Technical specifications	132
RAPTOR HV (ACCESSORIES)	133
Emergency pushbutton.....	133
Emergency light.	133
External shielded Cable for measurements.....	134
External Cable for injection.....	134
Electrodes.	134
V2in to V1in switch.....	134

DECLARATION OF CONFORMITY

For the Raptor system. Applicable to all elements comprised in the system.

Raptor MS / Raptor SL / Raptor HV / Raptor HH.

Manufacturer

EuroSMC, S.A.

Pol. Industrial P-29 C/Buril, 69

28400 Collado Villalba

Madrid – Spain

Declaration of Conformity

Based on the results of the testing conducted according to adequate standards, the product complies with the following:

- Directive 2004/108/CE relating to Electromagnetic Compatibility.
- Directive 2006/95/CE relating to Low Voltage.

Standards applied

Generic Standards

EN 61010.1 (2010)

Safety requirements for electrical equipment for measurement, control and laboratory use.

EN 61000-6-1 (2007)

Electromagnetic compatibility (EMC). Immunity for residential, commercial and light-industrial environments.

EN 61000-6-2 (2005)

Electromagnetic compatibility (EMC) .Immunity for industrial environments.

EN 61000-6-3 (2007)

Electromagnetic compatibility (EMC). Emission standard for residential, commercial and light-industrial environments.

EN 61000-6-4 (2007)

Electromagnetic compatibility (EMC).Emission standard for industrial environments.

Basic Standards

IEC 61000-3-2 (2006)	Electromagnetic compatibility (EMC). Limits. Limits for harmonic current emissions.
IEC 61000-3-3 (2009)	Electromagnetic compatibility (EMC). Limits. Limitation of voltage changes, voltage fluctuations and flicker.
IEC 61000-4-2/3/4/5/8/11	Electromagnetic compatibility (EMC). Testing and measurement techniques.





Testing has been conducted with a typical configuration. This conformity is indicated by the CE symbol, which means 'European Conformity'.

Standards applied to Raptor HV

IEC 61936-1:2010	Power installations exceeding 1 kV a.c.—Part 1: Common rules.
EN 50522:2012	Earthing of power installations exceeding 1 kV a.c.

ELEMENTS COMPRISED IN THE SYSTEM

Depending on the system that has been acquired, the following units will be included:

Raptor C-05	1 Raptor MS Master Unit 1 Raptor HH Control Console	
Raptor C-15	1 Raptor MS Master Unit 1 Raptor SL Slave Unit 1 Raptor HH Control Console	
Raptor C-25	1 Raptor MS Master Unit 2 Raptor SL Slave Units 1 Raptor HH Control Console	
Raptor C-35	1 Raptor MS Master Unit 3 Raptor SL Slave Units 1 Raptor HH Control Console	
Raptor CV-X5	1 Raptor MS Master Unit 1 Raptor HV Unit X x Raptor SL Slave Units 1 Raptor HH Control Console	

The following is included with each unit:

Raptor HH	1 Raptor HH Unit
	1 Ethernet cable, 2-m long
	1 USB connection cable, 2-m long
	1 universal power supply (100-240 VAC), with a5Vdc output
	1 stylus for touch screen
	1 cable for connecting the Raptor HH to the Raptor MS, 3-m long
	1 nylon protective cover

Raptor MS

1 Raptor MS Unit

1 power supply cable, 3-m long

1 cable for low-level measurement, 2-m long

2 pairs of connection cables (red-black), 2-m long

1 set of clips (red-black), medium, alligator type

1 set of 3 small clips, alligator type

2 spare fuses for the power supply

2 spare fuses for the auxiliary output

1 nylon protective cover

1 Calibration Certificate

Raptor SL

1 Raptor SL Unit

1 power supply cable, 3m long

2 spare fuses for the power supply

1 nylon protective cover

Raptor HV

1 Raptor HV Unit

1 Interconnection cable from Raptor MS to Raptor HV

2 bipolar clamps for 4 wires resistance measure

2 High voltage cable, 6m long

1 nylon protective cover

SAFE USE OF THE EQUIPMENT

Before using the equipment, you must carefully read this manual, especially this section, which refers to the safety precautions that must be observed.

Symbols used

Danger – It identifies actions and situations that represent risks to the user.



Caution – It identifies actions and situations that could cause damage to the equipment.



Important – It identifies actions and situations in which special attention must be paid to correctly conduct a test or take a measurement.

Dangerous Situations

Danger – Before changing the power connections or the power supply, be sure that the system is turned off (by deactivating the power switch of each unit).



Danger – After injecting high current, the cables and connections could be very hot and could cause burns.



Danger – Do not manually open a circuit through which current is flowing, given that high voltages could be generated.



Danger – Never connect the power supply cables to a line before connecting to the equipment.



Danger – When conducting resistance tests, be sure that the circuit is earthed to some point. If it is a switch, one of the sides must be connected to earth and the switch must be closed.



Danger – Before injecting current on the primary of a current transformer, be sure that its secondary is closed. Otherwise, high voltages may appear.



Danger – Never operate with the system if you observe severe damage to it or humidity on it.



Danger – Only handle the expansion hose connections when the system is off (deactivating the on/off switch of the Raptor MS unit).



Danger – Only handle the connections that intervene in a Raptor HV circuit when the system is off (deactivating the on/off switch of the Raptor MS unit).

Hazardous situations for the Raptor system



Caution – In systems with Raptor SL units, when preparing to conduct injections by pass-through turns, be sure that all the units are powered. This is necessary so that the thermal protection systems work correctly.



Caution – Do not inject using the pass-through turn simultaneously with the auxiliary output.



Caution – Do not try to lift the equipment using the fold-down handle. Instead, use the top handle.

INTRODUCTION

The Raptor marks the difference with respect to any primary injection testing equipment that currently exists. Its innovative design and cutting-edge technology allow substation commissioning and maintenance tasks to be carried out more efficiently, given that the concept of manageability is taken to extremes that were previously never possible to reach.

With the Raptor, SMC opens the door to a new generation of testing equipment based on the formula of innovation, designed with and for the user and endorsed by more than 25 years of experience developing practical, affordable and long-lasting solutions for its customers around the world.

As high-current injection equipment, the Raptor's design fulfils three fundamental objectives: 1) being able to bring equipment as close as possible to the device under test, 2) controlling current automatically and 3) only requiring one person.

The basic system (C-05) or 'master unit with console' is extraordinarily compact and manageable equipment, with a touch-screen console that allows making precise electrical measurements and conducting multiple types of testing, including high-current testing, for which it uses an elegant implementation of the secondary pass-through technique. A single conductor passes through the equipment from one side to the other in order to transmit the current to the object being tested, connected at its two ends. This saves preparation time and eliminates power losses. The wave shape, of variable frequency, is generated digitally and is extracted through a 3-kVA power amplifier with extreme precision and control, insensitive to the variations that might occur in the load and even in the power supply voltage.

The Raptor slave units, externally identical to the master unit, allow increasing the injection power in 5-kVA steps just by aligning them with the master and passing the injection conductor through the entire assembly. A sophisticated power management system, supported by a robust infrared communications channel, allows managing up to five Raptor units as if they were a single unit and without having to connect them to each other, thereby reaching an injection power of over 18 kVA and a current of up to 15,000 amperes. In addition to all this configuration flexibility, there is the possibility of increasing the applied voltage simply by looping the conductor around the equipment several times.

The Raptor HV, or high voltage unit, is an optional product that increases the Raptor system applications in order to include tests that require using AC high voltage, up to 2kV. This product operates together with the Raptor MS master unit and it looks very similar to it.

The Raptor HV is connected to the main unit pass-through the expansion port, from where it also takes the necessary power. The Raptor HV thus taps into the great advantages of the Master, such as electronic power regulation, DSP-based intelligence to control the tests, and a communication tuner system, and the robust device. The control of the high voltage unit is fully integrated into the HH console, and is just as user-friendly as the other tests.

The voltage generated by the master pass-through the expansion port is amplified by the HV unit up to two ranges that can be selected by the user, 1 kV and 2 kV. This high voltage power output incorporates voltage, current and phase angle meters on the inside, providing the appropriate injection control for all operations. The voltage and current measurements are high precision, permitting an ample variety of applications.

In compliance with international safety requirements, the Raptor HV unit includes a buzzer that indicates if the high voltage output has been activated, as well as two connectors for a rotating warning light and an emergency knob type switch, both of which are optional. The internal buzzer can be deactivated from the Raptor console.

The Raptor is managed using a small touch screen, which attaches magnetically to steel surfaces for greater convenience. Updateable by a direct connection to Internet, this powerful, multilingual controller also stores testing templates pre-configured at the factory, in addition to those defined by the user, as well as the testing results. Its software includes an assistant to determine the Raptor configuration and the necessary cable characteristics for conducting a specific test, even before leaving the office.

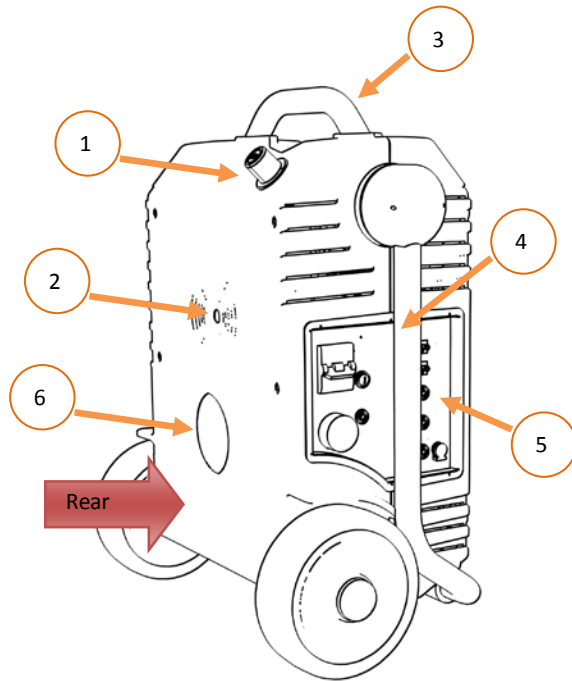
LOCATION OF ELEMENTS

1	Fold-down handle lock control.
2	Infrared communications port (not used in Raptor HV)
3	Top structural handle
4	Fold-down transport handle
5	Control panel
6	Hole for pass-through turn (not used in Raptor HV)
Rear	Rear part of the equipment

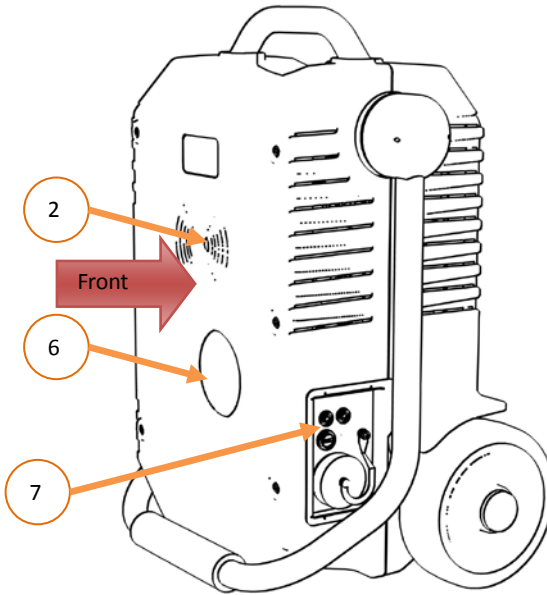

2 Infrared communications port (not used in Raptor HV)

6 Hole for pass-through turn (not used in Raptor HV)

7 Expansion panel

Front Front part of the equipment Phase reference for the pass-through turn.

Raptor MS (Control panel)



- | | |
|---|----------------------------------|
| 1 | Power supply control |
| 2 | Console and expansion connectors |
| 3 | Status indicators |
| 4 | Measurement inputs |

Raptor MS (Expansion panel)



- | | |
|---|--------------------------------------|
| 1 | Voltage and current auxiliary output |
| 2 | Expansion connector |

Raptor SL (Control panel)



- | | |
|---|----------------------|
| 1 | Power supply control |
| 2 | Status indicators |

Raptor HH

1 Top connection panel with USB, Ethernet
and power input

2 Touch panel

3 Status LEDs

4 Rotary and push button control

5 Bottom panel for connecting to Raptor MS
and stylus slot

Raptor HV (Control panel)

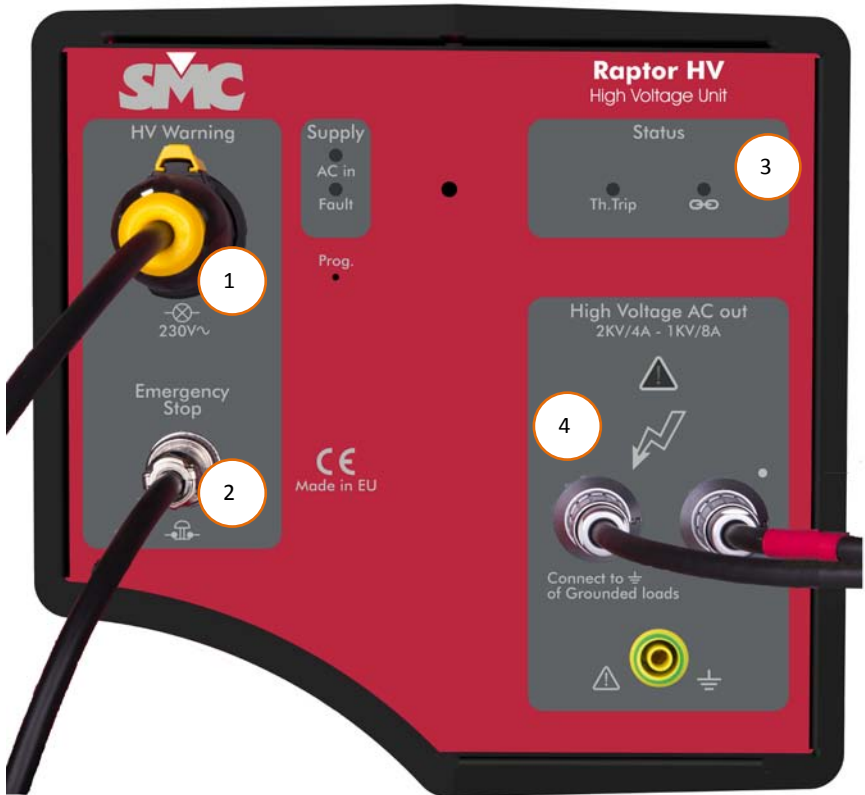

- | | |
|---|-------------------------------------|
| 1 | High Voltage warning lamp connector |
| 2 | Emergency stop button connector |
| 3 | Status indicators |
| 4 | High Voltage output |

HOW TO CONNECT THE SYSTEM

The Raptor system will be composed of at least one Console (Raptor HH) and one Master unit (Raptor MS). Depending on the configuration that you have acquired, you can also align up to 4 slave units (Raptor SL) and/or one Raptor HV unit.

To connect the system, you must first set up a power supply line with sufficient power/ cross-section to cover the power that your load requires, plus the losses of the generator. Even though this is difficult to know in advance, you can take into account the maximum admissible consumption per unit:

Raptor MS: 18 A permanently, 36 A for 3 minutes and 72 A for 3 seconds.

Raptor SL: 26 A permanently, 52 A for 3 minutes and 104 A for 3 seconds.

Raptor HV: No line power leads. It is powered from the Raptor MS unit.

You must keep in mind that the Raptor gives maximum power when fed at 240 VAC, measured at the start of the supplied power supply cable. To the extent that this voltage is less or drops during the test, the maximum current or maximum voltage will also drop.

Positioning of the equipment

When preparing to inject current using the 'pass-through turn', you must align the Master case with the Slaves units.



This makes it easier to pass the cable through the hole of each unit and allows the infrared communications channel of the Raptor units to work correctly (this communication, in both sides of units, is designed for being viewed directly and at a distance of less than 1 meter).



If the auxiliary Voltage / Current output is going to be used, make sure that no pass-through turn is closed.

And finally, in case of using the high voltage output of Raptor HV, connect it with the Raptor MS using the expansion cable.

Make the connections

Before continuing, be sure that the main switches of each unit are in the Disconnected position.

Connect the Console (Raptor HH) to the Master case using the cable provided.

Make the necessary connections, both injection and measurement. These connections will vary according to the nature of the test, which in some cases will be detailed later in this manual.



Connect the earth cables present in the supply hoses of the Raptor MS and Raptor SL units together and to an adequate earth connection

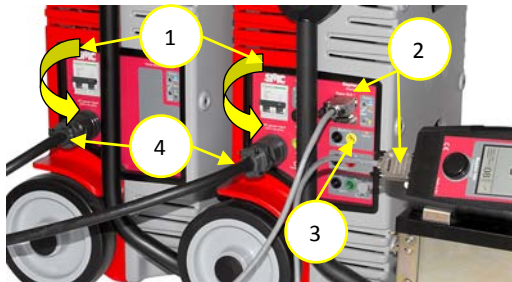

Now connect the Raptor MS and Raptor SL units to the power supply. Do not make this connection permanent, due to the fact that if several units are combined, the system requires that all the units be connected **with the same polarity**. There is no need to be concerned, because if the polarity is not the same, the system will detect it and will indicate on which ones the polarity must be changed.

The polarity is the position of the line and the neutral on all the units. The polarity of reference will be given by the polarity of the Raptor MS unit.



You will not be able to work with the equipment until all the units are connected with the same polarity.

If you are working with Raptor HV unit, connect the expansion cable between the Raptor MS and Raptor HV unit and its safety accessories.



- 1.- Expansion cable connector of Raptor MS.
- 2.- Expansion cable connector of Raptor HV.
- 3.- Expansion cable.

TURNING ON THE SYSTEM

Raise the main switches of each one of the units forming your Raptor system. The correct polarity and power supply status can be checked through the indicators on the control panel of each unit.



AC in green LED must remain On from the moment you power up the unit with the circuit breaker. Otherwise should check the line power, breaker, fuses etc.

Fault yellow indicator, when remain On, indicating a fault in one of the machine's internal supplies or line level too low for proper operation of the unit.

After turning on the system, it begins with system identification by the Raptor HH unit. The identification screen graphically shows how the system is connected. If any unit has been connected erroneously, with the polarity of the line inverted or the polarity of the unit inverted, this will be shown in the system's detection window. This error is also indicated by flashing of the **Fault** indicator on the case where the polarity is inverted with respect to the master case. The connectivity errors only can appear in Raptor SL units. Any connectivity error will not allow working with the system until the correct connection is made.

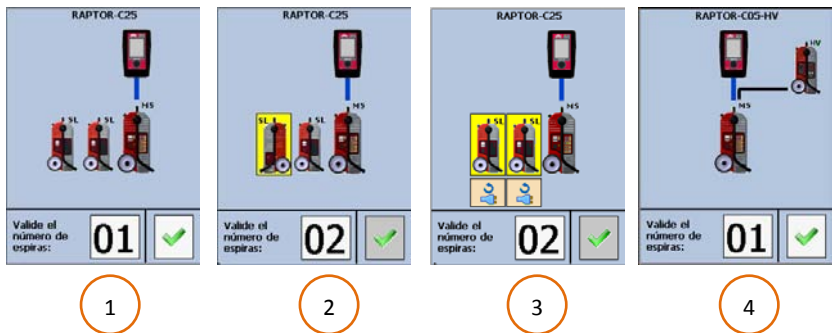

- | | |
|---|--|
| 1 | Units connected correctly. |
| 2 | Orientation error of a unit. |
| 3 | Polarity error in the power supply of two units. |



With the system detected as stable, all the units comprised in the same display their connectivity indicators (blue indicator) as permanently illuminated, thereby indicating that they were detected and recognised by the system. If this were not so, the unit would be flashing and would not be recognised by the system.

Siby indicator red, indicating that the unit is in a state of maximum protection. In this state remain at power, before any alarm (thermal, communications, power supplies, overhead, etc..) And at a reset.

Trip Ovd yellow indicator, (only present in the unit Raptor MS) indicates an overload on the output, this can be due to various causes such as load value too high etc.. This indicator will be deleted when activating power and in case of persistent overload it will activate again.

Trip Th yellow indicator, indicates thermal overload in the unit. While this indicator stays On will not be possible to power up the output. When the unit returns to the proper working temperature it will deactivate.

In Raptor MS unit, there are two **OUT** red indicators, one on the main panel and one on the expansion panel. The first is general and indicates that the power is on, regardless of the mode of generation selected. The one in the expansion panel indicates that the auxiliary output is active.

In Raptor SL unit, there are two but in this case indicate which of the two internal transformers are active.

With the system stable, the identification window reports the detected system according to the number of units comprised in the system (Raptor-C05, Raptor-C15, Raptor CV-05, etc.).

The only part of the system that cannot be detected is the number of turns that form the pass-through winding. Using the system detection window, you will have to enter the number of pass-through turns with which you will work. If you do not yet know or are going to work with the auxiliary output, validate the existing number. You can change it later. Press the dial to accept.

AN INITIAL VIEW OF THE CONSOLE

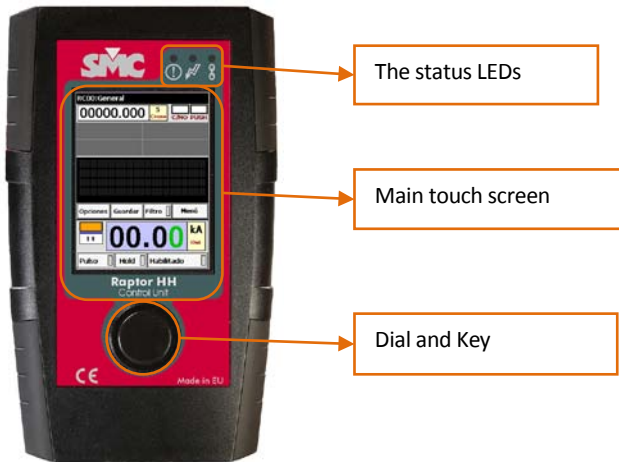

The status LEDs



The alarm LED (yellow) will indicate the presence of an alarm in the system. There are two types of alarms: critical alarms and non-critical alarms. Critical alarms are those for which the system prevents power from being supplied, such as an overload of the output, a thermal overload, etc. When such an alarm occurs, the LED will remain illuminated permanently. Non-critical alarms are those that are not destructive, and it is possible to continue working with the equipment, such as range saturation of the external meters. When this type of alarm occurs, the LED will remain flashing. Activation of either type of alarm will be accompanied by three beeps.

The power LED (red) will indicate the activity status of the output power.

The connectivity LED (blue) indicates that the Raptor system has been detected and is stable when it is illuminated permanently. When this LED is flashing, it indicates that the Raptor system is not stable with respect to connectivity.

Main touch screen

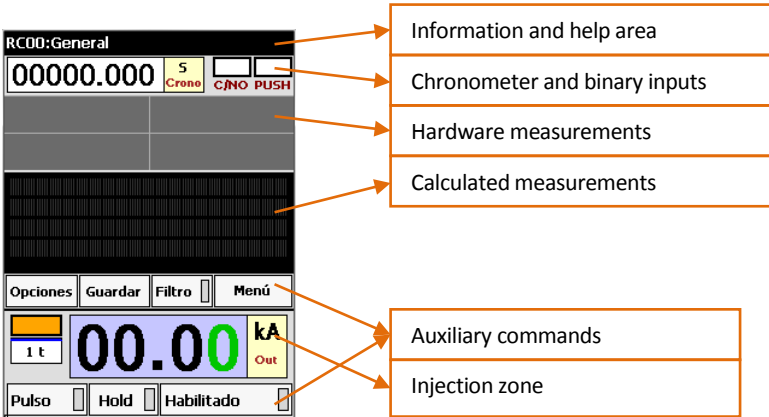

The main screen is divided into three main zones according to their functionality: Help and alarms scroll bar, measurements and injection.

Help and alarms scroll bar

This zone has a dual functionality: showing a help text for some parts of the screen and showing the alarm indicators.

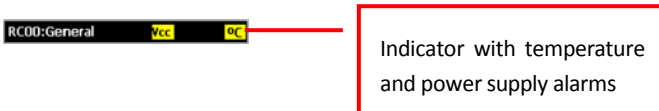

Alarms. The alarm indicators are displayed in this zone. There is an indicator for power supply failure (**VDC**), Temperature (**° C**), line voltage (**Vln**) and overload (**Ovl**)¹. The indicators are highlighted with a yellow background. The preceding image shows some indicators.

Stop Help texts. When tapping on certain controls of the screen, an indicative text of their function is shown.

¹Ovl. The system also uses this alarm to indicate that the “Emergency Pushbutton” is activated, as long as is activated.

Measurements zone.

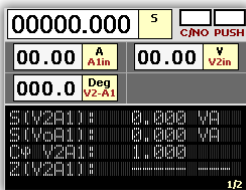

The controls that show the measurements taken by the equipment are located here. They can be **hardware** measurements (made by the Raptor circuitry) or **calculated** measurements (processed based on hardware meters). You can modify the meters you want to be displayed at any time and its configuration.

Meters configuration.

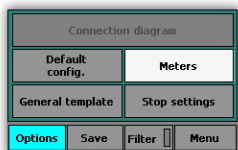

To add or remove meters, tap on the **options** button and then **meters**. A screen will be displayed where you can select the hardware and calculated meters. Many of the meters also have a button on their right-hand side to access the meter's settings. A maximum of four **hardware** meters can be displayed.

Time meter. Binary input indicator. Stop indicator



The first shows the time elapsed from start of power generation, until the Stop Condition is detected, or until the power is switched off again. To show the time from the start

of injection in three formats:

- Seconds, default value, with 1 millisecond resolution.
- Cycles, where each cycle is the equivalent to 20 ms in 50 Hz frequencies.
- hh:mm:ss.

Accuracy is 1ms, 0.01 cycle and 1s respectively. The maximum measurable time is 1 day, depending on the chosen format, it will displayed as 86400,000 seconds, 4.32 million cycles (at 50Hz frequency) or 23:59:59.

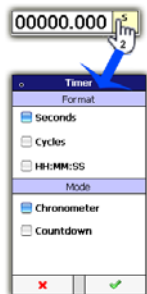

The timer always starts up when the on/off button is pressed. It can be switched off by a) pressing the on/off button, or b) stop condition.

It can work as a chronometer (ascending) or countdown (descending). In the latter case, when it reaches zero, the injection goes off.

To enter the system to configure the timer, this must be pressed twice.

The second indicator shows the status of the binary input. This indicator will be red when active.

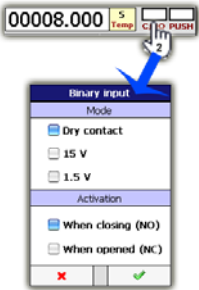

To configure the binary input indicator, tap twice on the control.

In mode section, **Dry contact** or **Voltage** can be selected. There is a choice of 2 activation thresholds in the voltage mode. The maximum voltage applicable to the input is 250 Vac. On the contrary, when the configuration is in **Dry contact** mode and the voltage applied to the binary input is more than 20V, the input protects itself by changing automatically to 15V Voltage mode. In this case, the binary input indicator flashes on and off. To restore this warning situation, enter the binary input configuration window and validate the configuration again.

The third one indicates that the stop condition configured has been fulfilled. The indicator will be on green in this situation. When the stop condition is activated, the other meters go to the **Hold** status.



To configure the stop condition, tap twice on the indicator or select the **options** button and then the **Stop Conf.** button. It can be not allowed configurations depending of the Raptor system working mode.



To erase the stop condition press over the indicator.

Hardware meters

A maximum of four meters can be displayed.



To configure them, press the meter control twice, or access Options and then Meters. When the digits of a meter are blue, this meter is working with automatic configuration. When hyphens are shown instead of digits, the meter is saturated.

Calculated meters



Press the panel of the measurements calculated to view the next pages.



The configuration of any meter can not be modified while HOLD is active or the power injection is enabled.

Injection zone.



This is where the controls and indicators related to power generation are located.

Generation level

This control is used to assign the level to be generated. To be able to modify the value, the control must be selected. To do so, tap on the control. The background will change to blue, and a digit will be displayed in green, thereby indicating that this is the digit that is going to be modified. To change the active digit, simply tap on the new digit.



To modify the power generation configuration, press the level control twice.



It is not possible to modify the power generation configuration whilst the injection is enabled.

Pre-injection indicator



This indicates that the next injection will start with a small level for a brief period of time (100 ms), to determine the load connected. The system works like that when it does not know the load; it carries out this pre-injection to detect it and be able to inject with precision and without excessive transients. It works like that when the indicator is orange.

Pre-injection is activated automatically in the following conditions:

- When the system is initiated.
- When changing the configuration or the generation mode.
- After an alarm.
- When 5 minutes elapse without having generated power.
- Manually, pressing twice over the indicator.



Making an accurate test: make a brief pre-injection (2 seconds) with pre-injection indicator active (sometimes you have to activate it manually) and with the system configuration and load as close as possible. Then, with pre-injection indicator off, make a normal test.

Generation enabling

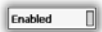

It indicates whether or not power generation is permitted.



If the power generation is enabled it will not be possible to modify the other system configurations.

Pulse



With this injection mode activated, the generation only turns on while you keep pressing the power push-button.

MAKING THE FIRST INJECTION

Injecting current.



Caution – If injection is going to take place through the auxiliary output, it is essential to leave the pass-through winding in an open circuit.



After making the connection sequence as explained in the chapter on “How to connect the System”, now the load must be connected.

The minimum required Raptor System adapts to each load-environment situation when it injects on its pass-through winding. While the number of Raptor units used, the number of pass-through turns, the length and cross-

section of the pass-through cables and the injection range can vary, there is an optimum combination for a minimum Raptor System. The majority of the application’s controls open up a window, thereby allowing the controls to be configured by tapping twice on them.



Important – The most powerful configuration (NOT the optimum configuration) for a desired current is obtained:

1. By using the greatest possible number of units.
2. By increasing the number of turns to the maximum, as long as the maximum selectable current on the Raptor HH continues to be greater than or equal to the desired current.
3. By maximising the cable cross-section, thereby attempting to occupy the largest possible space of the pass-through hole.
4. By minimising the cable length and the intermediate connections to the load.
5. By braiding the cable both to and from the load.



Important – The “Current calculator” is a utility included in the Raptor HH (also available for a PC), which helps to estimate an optimum Raptor System for each case.

Steps to follow



Important – The power injection must be disabled and the measurements must NOT be suspended to be able to access all the configurations.

1. Select the pass-through turns.

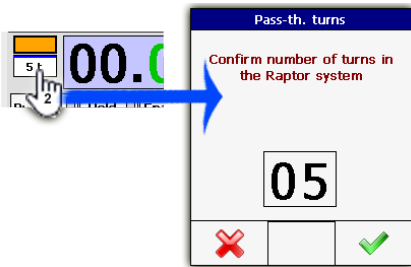

After clicking twice on the pass-through turn indicator, the system must be informed of how many turns have been wound in the hole. (If this indicator does not appear, go on to step 2 and then start again).

2. Select the injection mode and the measurement range.

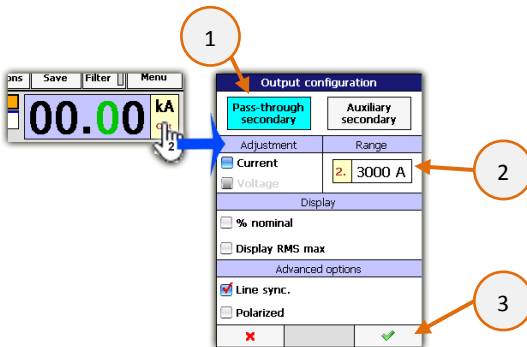

Select injection mode via pass-through secondary and the desired injection range. The possible current ranges drop when the turns configured in 1 are increased, unlike the voltages generated, which increase.

3. Chronometer configuration, stop condition and binary

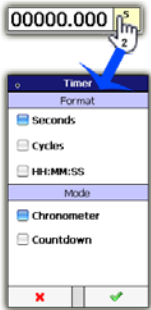

If you are going to take measure times, configure the chronometer. Decide if it will operate as Chronometer (ascending count) or countdown (descending count). If you choose Countdown, select the value.



Decide how to stop the test and the chronometer, and the meters will be suspended (pressing the rotating button, binary input, when opening the current circuit).



If you need to use it, configure the working mode of the binary input.

4. *Selecting the value.*



By tapping on the digit you would like to change and using the dial, select the current value that you want to inject.

5. *Enabling injection.*

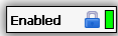

Tap on the button to enable injection. This function prevents the dial from being accidentally pressed.



Important – With injection disabled, the Raptor System will not generate through its outputs.

6. *Inyectar.*



Press the dial to start the injection. Current injection may end early due to:

- Press again the dial.
- Achieve the stop condition
- Having configured the chronometer in the 'Count-down' mode and the count has reached zero.
- Any alarm produced in the system.



Caution – Never leave the equipment injecting without direct supervision.

Injecting voltage with the Raptor HV unit.



When a Raptor system is used with a HV unit, it is not necessary to open the pass-through winding, or disconnect any existing slave cases in the system.

After carrying out the connection sequence as explained in chapter “How to connect the system), the load must be connected. The voltage generation by Raptor HV is not influenced by the number of turns in the pass-through winding, nor by the number of slave cases connected in the system. The voltage is generated only by Raptor MS and Raptor HV units, connected through the expansion cable.

Steps to follow

1. Select injection by Raptor HV.

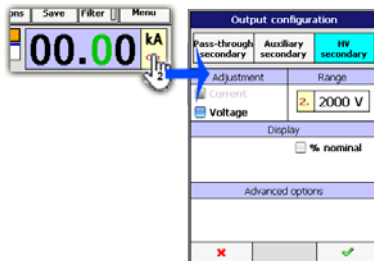

After clicking twice on the power control, select the injection mode by *HV Secondary* and the desired injection range. Possible ranges are 1 kV and 2kV.

2. Configuration of chronometer, stop condition and binary.

This configuration process is similar to that carried out with the generation by current. Consult section *Configuration of the chronometer, stop condition and binary* when generating by current. In this case, the *Ahv overcurrent* stop condition will be activated.

3. Select level.

This configuration process is similar to that carried out with the generation by current. Consult section *Select level* when generating by current.

4. *Enable injection.*



pressed.

As with injection by current, press the button to enable injection. The green indicator tells you if it is active. This function prevents the rotating control from being accidentally



Caution – Never leave the equipment injecting without direct supervision.

AVAILABLE MEASUREMENTS

The Raptor system has broad measurement capacity. On the one hand, it has the capacity to measure times, and on the other, various electrical magnitudes. This second group has been divided into three types. The first type are measurements called Internal Measurements, used by the system to adjust injection. The second type are 'Hardware' measurements, which are those obtained through specific electronic circuits included in the Raptor MS or Raptor HV cases. The third type, 'Calculated' measurements, is obtained through calculations based on the Internal and Hardware measurements, to get more complex magnitudes.

Internal measurements

These measurements are related directly to the injected magnitude, and they are not directly visible, given that they are those that the processor uses to adjust the injected magnitude selected by you.

The main current meter is a Rogowsky type of sensor included in the Raptor MS case, which surrounds the hole where the pass-through turns are inserted. Due to the characteristics of this sensor, it measures the total current flow passing through the hole. This is why, when using injection by pass-through turns, you must be sure that the number of turns specified on the console is the actual number. Even though this type of measurement is very precise, to improve the measurement the system has 2 ranges, which you must select. You can access this configuration as described in step 2 of the chapter, "Making the first current injection".

When you use injection through the auxiliary Voltage or Current outputs located on the expansion panel of the Raptor MS unit, there is also an internal measurement of these magnitudes. This is a low-accuracy measurement. If you require greater precision, it is advisable to simultaneously use the external meters to compare the real injected value.

If the HV output of a CV-X5 system is used, the Raptor HV unit has an internal voltage meter, not directly visible, used to adjust the voltage level at output to the value selected by you.

Hardware measurements



In addition to the binary input, the main panel of the Raptor MS unit has three measurement inputs, two for voltage and one for current.

These inputs are connected to level sensors on one side and are taken by pairs (including the internal measurements) to phase sensors.

The *A1in* current input shares circuitry with the *V1in* low-voltage input, and they both cannot be used at the same time. An orange zone on the selector indicates which one is active (even though it has not been configured for display).

The 'Hardware' measurements are obtained based on these

sensors.

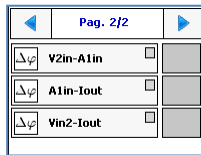

Eight 'Hardware' measurements are available:

- High level external voltage measurement. (*V2in*)
- External current measurement (*A1in*).
- Low level external voltage measurement (*V1in*).
- Phase measurement between *V2in* and *A1in*.
- Phase measurement between *V2in* and *V1in*.
- Phase measurement between *V2in* and *Iout* (output current).
- Phase measurement between *A1in* and *Iout*.
- Phase measurement between *V1in* and *Iout*.

Given that *A1in* and *V1in* cannot be used simultaneously, only 6 of them can be selected for display in each case.

The following image shows the *A1in* and *V2in* meters:

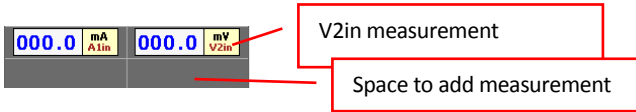

The 'Hardware' measurements zone has four display cells. Therefore, there are a maximum of four 'Hardware' measurements that can be viewed on screen at the same time. The cell occupied by each added measurement doesn't always have to be the same; it depends on which and how many meters you may have added.

A measurement of this type shows three different data:

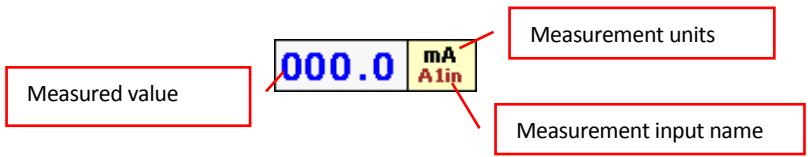

If the value of the measurement is in **blue**, it indicates the automatic range setting.

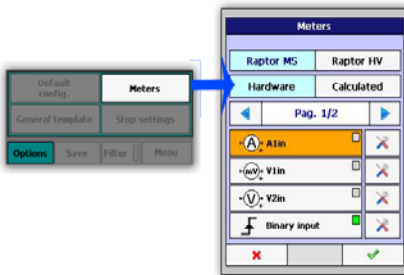

To select the 'Hardware' measurements, proceed as indicated in the figure.

It can be seen in the image, that the 'Hardware' measurements are selected. The 'Calculated' measurements are described in the next section. There are two selection pages.

The green/grey LED of each meter indicates if the measurement is selected for display.

To access the measurement setting, tap on



The A1in, V1in and V2in measurements are configured as follows:

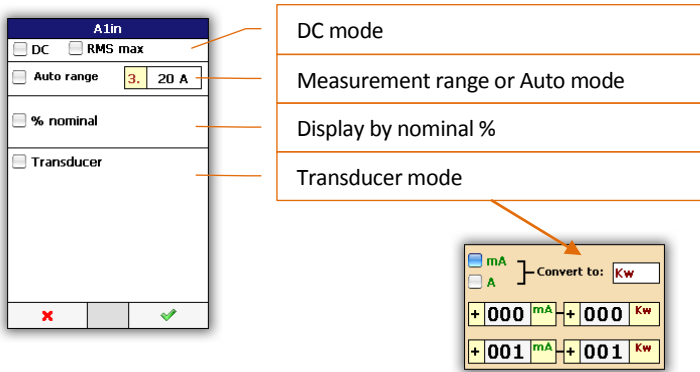

The transducer mode allows you to adjust the magnitude shown on screen to the transducer's conversion characteristics, thereby allowing the units, scale and offset to be changed.

Phase measurements have no configuration.

If you have a CV-X5 system, the Raptor HV case does not have measurement inputs. The hardware meters of this case show internal magnitudes of the system. If you use the injection via voltage output, you can select between the following meters:

- Current measurement (A_{hv}). It has configuration.
- Phase measurement between A_{hv} and V_{hv} . It has no configuration.
- Phase measurement between $V2in$ and V_{hv} . It has no configuration.

Calculated Measurements

```

S(V2Io): 0.000 VA
S(V1Io): 0.000 VA
Q(V2Io): 0.000 VAR
P(V1Io): 0.000 W
    
```





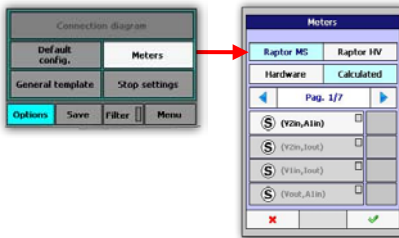



Based on the aforementioned Internal and Hardware measurements, the calculated measurements are obtained through calculations.

Up to 4 measurements are shown on each page. The number of pages of Calculated measurements will depend on how many have been selected. The current and total pages are shown in the lower right-hand corner. To move from one to another, tap on any part of the black zone.



To select the 'Calculated' measurements, proceed as indicated in the figure.

There are 8 possible types of measurements:

-  Apparent power
-  Reactive power
-  Total power
-  Power factor
-  Impedance
-  Reactance
-  Resistance
-  Transformation ratio

Only the ratio measurements have configuration available. Tap on

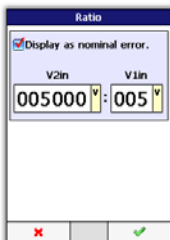

If you activate the option, 'Show as a nominal error', the screen will show the ratio error with respect to the ideal that you must configure in the table that will be displayed.

Functions related to measurement

 **Hold** button. After tapping on it, the values of the measurements are maintained, both 'Hardware' and 'Calculated' measurements, in addition to the values shown on the chronometer and the binary input. If it were already activated, by tapping on it, the meters would be released and the currently measured values would be shown. This mode is activated automatically when injection is stopped due to the Stop condition having been selected. With a new injection, this mode is deactivated automatically.

 **Filter** button. It allows activating the average of measurements, thereby allowing them to be stabilised in noisy environments. Measurement averaging is for 5 seconds. However, this cycle re-starts as soon as the variation of the measurement exceeds a certain threshold. Thus, even though this function may be active, tracking in the event of changes is quick.

OBTAINING THE TEST REPORTS

The Raptor system is equipped with the capacity to save the results of tests for subsequent review or for printing the test reports through the RaptorSync programme (for a PC).

Concept of Report and Test.

A test encompasses all the testing performed, including: the measurements that may be configured for display on screen, the measured time, the injected level and, in general, all adjustments and alarms.

The report is a grouping of the tests under a common name and comment.

How to use the Reports and Tests.



To activate the capacity to save the results of a test, you must have previously a report open. You can know if you already have a report open by the status of the **Save** button. If it is disabled, it indicates that no Report is already open.

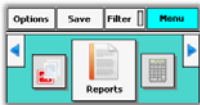

To open a report:

Tap on **Menu** and then browse to the **Reports** icon, either using the arrows and tapping on the icon or using the dial and then pressing it.

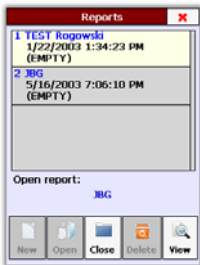

If the **Close** button is active, it means that a report is already open, whose name will be displayed at the bottom. To create a new one or open an existing one, you must first close the current one. The report is kept open even if the system is turned off.

If you decide to create a new one by tapping on the **New** button, you will be asked to enter the name and a brief

description to facilitate subsequent identification.

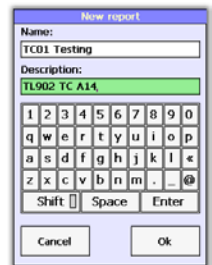

From the Reports screen, you can also open a report for review by tapping on **View**, or you can delete it by tapping on **Delete**. When a report is deleted, the tests contained in the same are also deleted.

With a report open, you can save the Tests simply by tapping on the **Save** button of the main screen.



In the submenu, you can save the results of a test without specifying anything else by using the **Save test** button, or you can specify a comment using the **Save test with comments** button.

You also have a button available for deleting saved tests in reverse order. **Be careful when using this last button, given that it will not ask you for confirmation.**

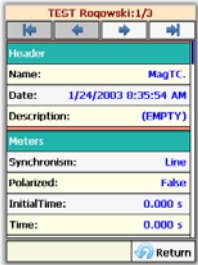

When View button is tapped with a Report previously selected, a new window will open up, where you can review each of the saved tests. There you have a scroll bar for going from one to the next. Using the dial, you can move up and down through the Test.

Using the RaptorSync programme (for PC with Windows)

With your Raptor system, you will have received the RaptorSync application, an auxiliary feeder cable for the Raptor HH console and a USB cable. This is all you need to view, import and print reports from a PC with the Windows operating system.

If you do not have the programme, you can download it from:

64-bit operating systems.

<http://eurosmc.com/downloads/RaptorSyncInstaller64.msi>

32-bit operating systems.

<http://eurosmc.com/downloads/RaptorSyncInstaller32.msi>

Install it, but **do not run it yet.**

Windows XP operating systems

Before being able to use the RaptorSync programme, you must install the ActiveSync communications utility, Ver. 4.5 or later supplied for free from Microsoft.

Installation of Microsoft's ActiveSync.

If it has never been installed, proceed according to the instructions provided by Microsoft for installation, and restart your computer when asked to do so.

After restarting, you'll see an icon such as the following on the tool bar of your desktop:



By double-clicking on the icon, the ActiveSync programme will open.

Preparing communication



Once the ActiveSync programme is open, a screen similar to the following will open. (the screen may vary according to the installed version)

From the File menu, select Connection Settings...



The following settings screen will be displayed:

Since you are going to connect using a USB cable, it is not necessary to mark those settings that refer to the COM serial port.

Click on OK.



Establishing communications

Now connect the console to the PC using the USB cable. Power it using the auxiliary power supply provided.

If this is not the first time you perform this operation, go directly to the next step.

If it is the first time, a screen such as the following will be displayed:

Select 'Yes' and click on the 'Next' button.

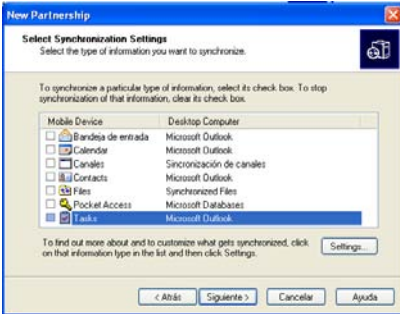

At this screen, select 'Files' and click on 'Next'.



A message will be displayed, warning that a folder is going to be created on your desktop. Accept it.



This screen, with the green icon to the right, indicates that you have successfully finished the connection process.

Windows Vista, Windows 7 and Windows 8 operating systems

The first time you connect the console to a PC, you must have an operational Internet connection. When the Raptor HH console is detected, the necessary Microsoft software for establishing communications will be downloaded automatically to your PC.

After installation and restarting your PC, if required, upon connecting the Raptor HH, you'll see the following screen:



You can close it.

Running the RaptorSync programme



Be sure that you have connected the Raptor HH console, and click on the icon that will have appeared on the desktop.

This screen will be displayed.

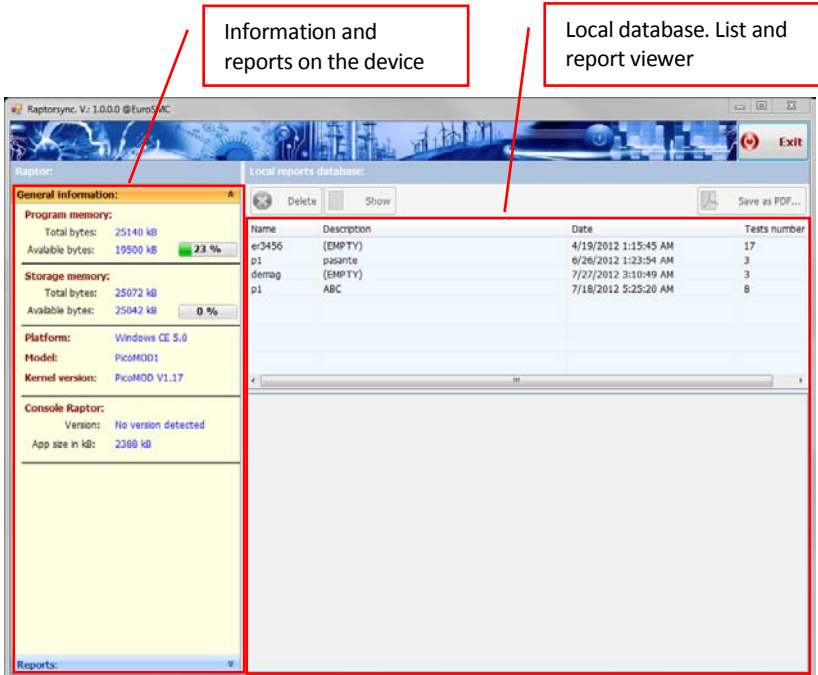

Information and reports of the device.

Two panels can be distinguished:

Information panel: it shows both hardware information (available and total memory, available and total storage, hardware version, etc.) and software information (software version of the hand-held unit). To access this information panel, click on the arrow at the header of the information:





Reports panel: it shows the list of reports that exist on the device. To display this panel, click on the arrows in the reports header:

Three types of actions can be taken with the reports list:

- **Import.** It imports the database from the device to a local database. It does not require confirmation to perform the action.
- **Delete.** It deletes the report directly from the device. Once deleted, it cannot be recovered. It requires confirmation to perform the action.
- **Show.** It shows the report directly from the device.
- **Update list.** It updates the reports list from the device.

Local database.

It is formed by two panels:

Reports panel. It shows the list of reports that exist in the local database. This database is always visible.

Name	Description	Date	Number of tests
SET UNI	(EMPTY)	11/7/2014 11:11:04 PM	0
cd 1	(EMPTY)	3/21/2013 11:40:44 AM	4
elob	demo	4/4/2013 11:02:46 AM	2
fu1h7	(EMPTY)	1/7/2003 9:32:51 AM	2
piu	60hz	9/21/2012 2:15:22 AM	1
smc	(EMPTY)	3/25/2013 2:00:26 PM	1
ttg7ue	hu7d	1/6/2003 8:48:50 AM	1

Three types of actions can be taken with the reports list:

- **Delete.** It deletes the selected report from the database. Once deleted, it cannot be recovered. It requires confirmation to perform the action.
- **Show.** It shows the report selected in the bottom panel.
- **Export...** It allows to select the file format to export the report displayed. The options are PDF, HTML or Excel file.

Report display panel.

It displays the report selected in the list of the local database. A Vc Magnetisation test and its graph can be seen in the following image.

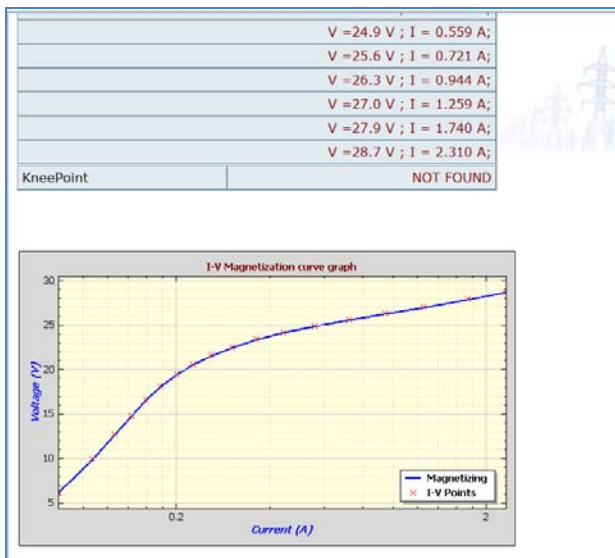

OTHER POSSIBLE INJECTIONS



The Raptor MS unit has auxiliary outputs to be able to inject small currents or high voltages that are essential in certain tests.

If working with predefined templates (see chapter "Management of predefined templates"), this selection will be made automatically.

To select the injection mode by auxiliary outputs:

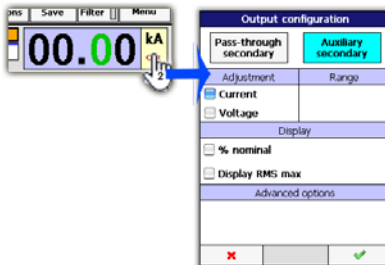

Press *Auxiliary secondary*.

Then decide if you want the output to be controlled in Voltage or Current.

Injection ranges cannot be selected in this mode.

This model will be indicated in the injection control area.



If you have a CV-X5 system, the high voltage output can be selected. Press **HV secondary**. After that, select the output level range.

It can only be controlled by Voltage.

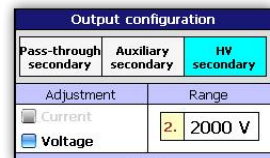

A screen may appear if the mode selection controls are disabled. This is due to the fact that you are using a predefined template and this template is already establishing the type of injection.

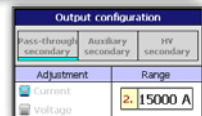

To permit the configuration in this case:

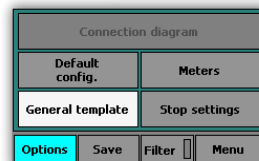



It is not possible to modify either the configuration/mode or the generation or the pre-injection when power generation is enabled.



Caution – If injection is going to be carried out through the auxiliary output it is essential to leave the pass-through winding in open circuit.

ANTICIPATING THE CURRENT THAT WILL BE OBTAINED

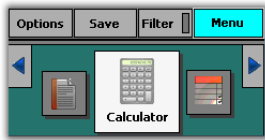

A large number of variables normally intervene in the generation of currents. Some are common to any injection system, such as, for instance: length and cross-sectional area of the connection cables; load impedance or the system power supply voltage and others are unique to the Raptor system, such as: the number of slave units; the number of turns wound in the pass-through hole; etc.

To make it easier to give a prior estimation of the current it will obtain, the Raptor system incorporates a powerful calculator as part of the Raptor HH console control application. Thanks to this system, a lot of trial and error time, or using an over- or under-dimensioned configuration will be avoided. This calculator is also available as a standalone application executable in PC with Windows O.S.

This has been designed in simulator format, in other words, you enter the data of the components available or which may be available and the calculator will inform you, at all times, of the current you will obtain with a considerable degree of accuracy. You can vary any parameter at any time and the results area (on the second screen) will vary accordingly.

You can carry out the calculations, only using the console, without the need for other units, before moving to the test place.

Data entry

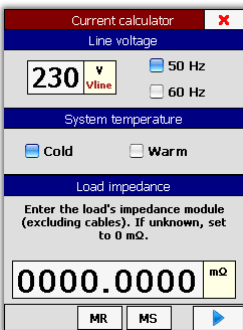

The screenshot shows a software window titled "Current calculator" with a red title bar and a close button. It is divided into three sections:

- Line voltage:** A large digital display shows "230". To its right are radio buttons for "50 Hz" (selected) and "60 Hz". A small "Vline" label is next to the display.
- System temperature:** Radio buttons for "Cold" (selected) and "Warm".
- Load impedance:** A digital display shows "0000.0000" with a "mΩ" unit selector to its right. Below the display is the text: "Enter the load's impedance module (excluding cables). If unknown, set to 0 mΩ." At the bottom are three buttons: "MR", "MS", and a right-pointing arrow.

The calculator has two screens:

The system supply voltage and the frequency must be entered in the first screen.

As the resistivity of copper changes considerably, you are given the chance to choose the system temperature, so that the results are more accurate. If you are considering carrying out spaced tests, choose **Cold**; otherwise, if you are going to carry out long-lasting or very repetitive tests, choose **Hot**.

If you know the approximate load impedance, enter it. If not, set to 0. The maximum current in this type of test normally depends on the actual system, more than on the load, which is usually very low.



You may also save the data entered **MS** and recover them **MR** in three memory positions.

When you have finished, go to the next screen. You can move freely back and forth between the two without losing data.

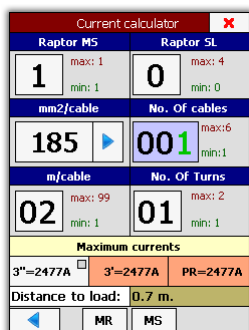

The selections are made as normal on the console; tap on the table you wish to change and use the dial. In some cases, when a number is highlighted in green, it will be possible to change it just by tapping on the one you desire.

On the right of five of the parameter selectors, you will see that the system indicates the maximum and minimum you can select. The system can automatically rectify the values entered when you change any of those that these depend upon, to set them within the limits.

At the top, you must configure the number of Raptor SL units you wish to use. For the moment, the number of Master units is fixed.

The **cross-section selector** of the cables **mm2/cable** permits, when by pressing the blue triangle, shifting between the standard in mm2 and the American standard AWG. The cross-section you must enter is the cross section of each one of the cables, not the total in case you are going to use several in parallel.

The **No. of cables** selector enables you to define how many of them you will use in parallel. You will see that the maximum indicated varies depending on the cross-section. If you use the ultra-flexible type of cable that can be supplied as an option with the Raptor system, you must reduce this maximum by 10% as it is thicker than normal.



The **m/cable** selector must be used to indicate the length of the cables to be used. The system uses this information to determine how many turns it can carry out and also the distance to load, apart from calculating the current. The configuration of Raptor SL units is taken into account to determine the length consumed in turns.

The results of the calculation.

Maximum currents		
3"=2477A <input type="checkbox"/>	3'=2477A	PR=2477A
Distance to load: 0.7 m.		

Maximum currents. This shows the result in maximum currents in three work regimes: 3 seconds, 3 minutes and permanent regime.

The maximum current indicator fields supply another type of information, apart from the current value.

	White background	No cable cross-section warning
	Orange background	Warning that for the selected cross-section, the current density may exceed the recommended maximum. These maximums depend on the work regime.
	Indicator ON	The current will be limited by the system

When the indicator is ON or the background is orange, a description of the problem or warning will appear when the rectangle is pressed. The description will disappear when the rectangle is pressed again.

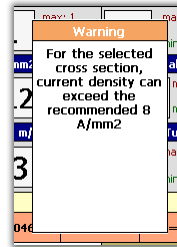

Distance to load: This shows the distance at which the load can be situated from the system. For the calculation, it considers the unit composition, the number of turns and the cable length.

MANAGEMENT OF THE PRE-DESIGNED TEMPLATES

The Raptor system can carry out a lot of tests thanks to its measurement inputs, on the one hand, and to its injection capacities, on the other hand. However, for these tests to be able to be carried out comfortably, quickly and error-free, there must be a basic method that is very easy for the operator to understand and apply.

That is what the Test Templates are. They allow the operator immediate access both to the control and to the necessary measurements for each one of the tests proposed. The system is automatically configured when a template is selected. The injection mode will also be selected.

There are two types of Template:

 **Factory templates:** Already created by default and available at all times. They can be used as they are or be edited by you.

 **User templates:** These are Templates that the user can create and save with his own name to be used at any time. They can be created based on the Factory Templates or directly.

Template management

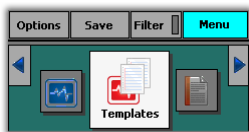

Access the template menu.

The management screen will appear. You can move up and down the list using the dial or by tapping on the screen

and dragging.

You can choose: to create a new template; copy one of the existing ones or use (load) one of the existing ones.

If you press **New** or **Copy**, you must enter a name and after pressing accept, it will appear on the list. A new template will be created in both cases, the difference being that if you select "New" it will start with the basics, to start from zero, and in the case of "Copy", it will inherit the configuration of the template selected to copy. Templates generated in this way are totally configurable. Templates created by you can be deleted; the Factory ones, on the contrary, cannot.

As a general rule, the Factory templates are associated with an injection mode and this cannot be changed. The only exception is the template called **General** (or basic).

RC00:VTburden

Select a template and press **Load**. You will always see the name of the current template at the top of the screen.

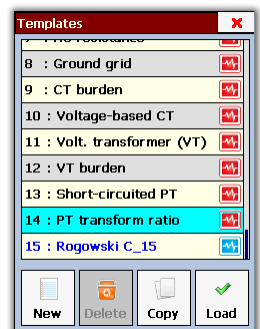

When you make changes to a template, the change will be saved, without requiring any additional action, even if you switch off the equipment or change screens.



If you are using a Factory template, you may always return to the default configuration (without changes). This button is not enabled on user templates.

If you have chosen the “use factory template” (just by loading it) and if you want to save it after modifying it without the danger of anyone returning it to its “default” state, go to the template management menu and create a copy. Copies are executed taking the modified templates and not the original ones as origin.

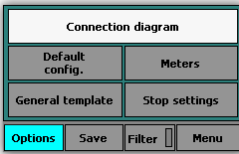

Most templates include a *connections diagram* to help the user with the cabling for a particular test type.

After loading a template that includes a connections diagram, the **Connection diagram** button in the **Options** menu will be enabled. Press this button to view the diagram and press the diagram to exit to the template’s

test layout.



There are templates that can only be used for Raptor CV-X5 systems (with Raptor HV case). Should you not have this system, when attempting to load these templates, a message appears indicating the impossibility of doing so. If you worked with one of these templates available for a CV-X5 system and you turn the system on again without a Raptor HV, you will be requested to select an appropriate template for your system.

Description of Factory templates



General

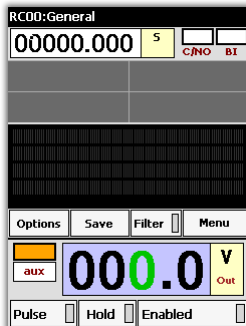

The GENERAL templates permits selecting and controlling any output value, in any of the generators that the Raptor system possesses. This is the basic control mode of the equipment. This can be selected directly by pressing on the **Options** button.

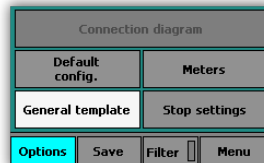

Furthermore, it is the minimum template on which an operator can develop his own test templates. To use it, simply select the generator you wish to use (Pass-through turn or Auxiliary Output), enter the desired value and activate the output.

Circuit breaker 

Circuit breaker

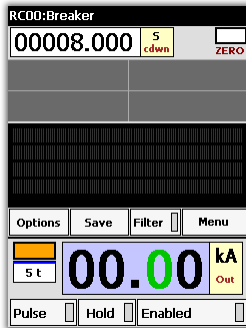

One of the more classical applications of a high current injection equipment, is the trip time test of thermo-magnetic circuit breakers (generally low voltage) directly connected to the mains, in their different construction forms:

MCB, corresponds to Small Automatic Circuit Breakers (generally up to 125 A nominal current)

MCCB, corresponds to Automatic Moulded Case Circuit Breakers (they can reach up to 4000 A nominal current)

The test consists of measuring the trip time of the circuit breaker at different current values, so that, when compared with its nominal trip curve, the correct or incorrect behaviour of the circuit breaker can be verified under test conditions, both in terms of its thermal element and its magnetic or instantaneous element.

Template configuration:

The template is configured as follows:

- Generator: pass-through turn
- Time display: As chronometer in seconds.
- Chronometer start: ON output
- Chronometer stop: Due to lack of current

Connections:

Connect the output of the pass-through turn to each side of one pole of the circuit-breaker tested. The circuit breaker must be closed.

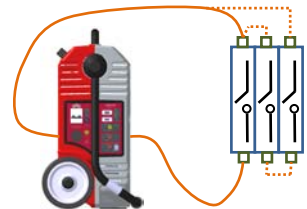

If you want the current to pass through all the poles of the circuit breaker, you must connect them all in series. However, you must make sure that this connection between poles is carried out with minimum possible impedance as your Raptor configuration may be able to inject to one pole but not to all of them.

Test:

Select and inject the desired current. The chronometer will start up. When the circuit breaker trips, it will stop, indicating the trip time. If you wish to test another point of the curve, repeat the process at another current value.



Caution – the trip times of a thermal element may be relatively high, even reaching many minutes. It is necessary to guarantee that the cross-section of your connection cable can support the current during the necessary time. (see Calculator)

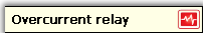

Overcurrent relay

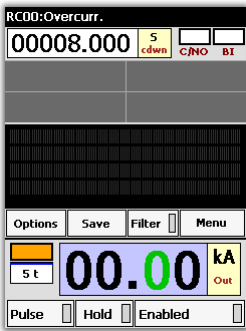

This test, also very frequent, consists of injecting a fault current through the primary of the CT and verifying the correct operation of the associated protection in secondary of this CT and the effective trip of the MV/HV circuit breaker, which must control this. It is a very good way of verifying that the Primary/Secondary/Primary chain works perfectly.

The primary of the CT must be injected with currents above the nominal current to simulate a fault current. In this case, it is especially important for the impedance of the connection between the equipment and the CT to be as low as possible. This is achieved with adequate cable sizes, correct geometric layout of the cable in its path, in order to reduce the turn area that is created to a minimum, and above all, to keep the shortest possible distance to the CT. In many cases it is highly recommendable to move the Raptor equipment close to the CT, using the people elevator buckets.

Although the relay trip time is verified, the primary aim of this test is not to verify it as such, which is assumed to be tested in secondary, but to verify the aforementioned chain.

Template configuration:

The template is configured as followed:

- Generator: Pass-through turn
- Time display: As chronometer in seconds
- Chronometer start-up: ON output
- Chronometer stop: By dry contact N.O.

current, in Impedance (Z) and the power factor of the burden $\cos(\phi)$. The ratio must always be measured at a burden that must be known, as it varies with this.

Template configuration:

The template is configured as follows:

- Generator: pass-through turn
- Time display: As a timer in seconds (8 s, maximum duration of high current injection)
- Secondary current meter input A1 in in Amps. Auto mode (current in CT secondary)
- Voltage meter in secondary input V2in in Volts. Auto mode (Voltage drop in CT bushings)
- Phase angle meter between currents A1in and Io. (Polarity and angle error of transformer)
- Phase angle meter between voltage measured in V2in and current measured inA1in (phase angle of burden connected to CT)
- Apparent Power (S) Meter (V2A1) using inputs V2in and A1in, in VA.- (Apparent power in burden connected to CT)
- $\cos(\phi)$ power factor meter (V2A1). (Power factor of the burden connected to CT)
- Impedance (Z) meter (V2A1) in ohms. (Total impedance Z of burden connected to CT)
- I0/A1 ratio meter. It presents the reading in terms of Current in Primary/Current in Secondary. If the theoretic ratio of the CT has been entered during the configuration of this meter, in terms of nominal primary current and nominal secondary current, this meter will present the primary current nominal value entered and the corrected value via the measurement of the respective nominal secondary current, regardless of what were the injected and measured currents, thus indicating the ratio error.

Connections:

Connect the output of the pass-through turn to each side of the CT Primary. The two bushings of the primary may be indicated as P1, P2, or in some cases as H1, H2. S1 and S2 correspond to this primary indication in the first case, and X1 and X2 in the second case. As a general rule, when you connect the primary to the pass-through turn and the secondary to be measured at the measurement input this must be done as

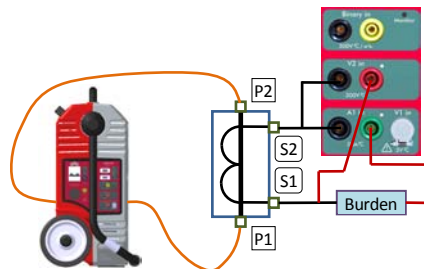

shown in the diagram.

With this connection, the phase angle between primary and secondary must be zero or very close to this value, indicating correct polarity. It is important to connect the voltage measurement directly to the CT secondary output bushings to include the entire burden of the CT, and not just part of it, in that measurement. (See diagram)



DANGER – Make sure that the CT secondary is properly connected to its receivers. Injecting current into the primary with an open secondary is very risky both for the CT and for the operator, as the CT may even explode.

Test:

Select and inject the desired current. The timer will start up. When the countdown reaches zero, the injection will stop.

If you wish to test another point of the CT, repeat the process at another current value.

When testing a CT, it is usually advisable to test the ratio error and phase angle at different primary currents, above all if this is a measurement CT. It is advisable to do this at 120%, 100%, 50% and 20% of its nominal current. If it is a Protection CT it is more important to test the ratio at the highest possible points permitted by your RAPTOR system, apart from at 100%.

If you observe that the measurements are unstable, and the values are continuously changing, use the *Filter* option to see the most stable values.



If you find the default measurement time established on the Template (8 s) short and you wish to increase it, do so, but bear in mind the cable cross-section used (the cable may overheat) and above all, the overcurrent values and the maximum time supported by the CT being tested without a risk of damage.

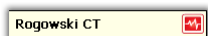

Rogowski CT

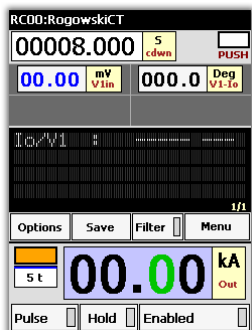

Current Sensors or Transducers, based on the so-called Rogowski coil principle, are being used more and more frequently today. They are combined with electronics that condition their output, thus presenting a greater advantage over the traditional induction CT, in terms of the total absence of saturation, as they have no magnetic core.

Furthermore, they have secondary voltage, presenting a ratio that is generally defined as xxx A/ yyy mV or it can also be frequently seen as xxx mV per Ampere.

The measurement inputs of the devices that use this technology have high impedance as what they have to measure is voltage, and their burden is irrelevant. Thus, in general terms, there is no need to measure it.

Otherwise, it behaves exactly the same as an induction CT, insofar as its ratio precision and polarity are concerned, and these are the two most important parameters to be measured, which is what the template does.

Template configuration:

The template is configured as follows:

- Generator: Pass-through turn
- Time display: As timer in seconds (8 s, maximum length of high current injection)
- V1 in input secondary voltage meter in Volts. Auto Mode (voltage in secondary of Sensor).
- Phase angle meter between voltage V1 in and primary current Io. (Polarity and angle error of Sensor).

Connections:

Connect the output of the pass-through turn to each side of the Primary of the Rogowski sensor (or pass the cable through the center space, where appropriate). The indication of the direction of the polarity is inconsistent, but it is often similar to the classic CTs. In general, when you connect the primary to the pass-through turn and the secondary to be measured in the

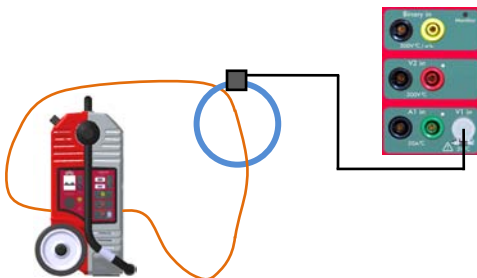

voltage measurement input V1 of the equipment, follow the steps below:

1. Connect the GREY coloured side of the RAPTOR to the input indicated as "Incoming current" of the Sensor.
2. Connect the RED coloured side of the RAPTOR to the input indicated as "Outgoing current" of the Sensor.
3. Connect the RED bushing of measurement input V1* to the secondary output of the Sensor, indicated as V.
4. Connect the BLACK bushing of measurement input V1* to the secondary output of the Sensor, indicated as 0.

**The level of the measurement input V1 is very low so a cable with a special connector is used (supplied with the equipment) to shield the measurements well from possible electromagnetic noise. In ambients where there is loud noise, the tip of the YELLOW cable (Earth) must be connected to the earth of the system, or at least to the BLACK tip of the measurement cable.*

With this connection, the phase angle between primary and secondary must be zero or very close to this value, indicating correct polarity. If the device tested is a direct Rogowski sensor, not electronically compensated, the standard correct value is 90°.

Test:

Select and inject the desired current. The timer will start up. When the countdown reaches zero, the injection will stop and the HOLD key will be activated, blocking all the measurements and ending the test.

If you wish to test another point of the Sensor, repeat the process at another current value.

When a Sensor is tested, it is usually advisable to test the ratio error and phase angle at different primary currents to verify linearity.

If the measurements are seen to be unstable, and their values are continuously changing, use the FILTER option to see the most stable values.



If you find the default measurement time on the Template (8 s) short and you wish to increase it, do so, but bear in mind the cable cross-section used (the cable may overheat).

Low power CT 

Low Power CT



This template is identical to the one described above, so we refer to that for its use.

Indeed, different systems have appeared on the market to carry out the same function as a classic CT, but with advantages over it (economic, size, lack of saturation, etc.) for certain applications, especially in low voltage.

Different systems are used but, for our application, we are only interested in knowing what converts the primary current into a low level voltage, proportional to this current, and consequently they are tested the same.

However, the linearity and angle acceptance criteria between primary and secondary may vary depending on the different types of sensor.

AC resistance 

AC Resistance



The contact resistance of circuit breaker poles, sectionalizers, busbar connection points, and cables, etc. must be verified during any start-up or maintenance of primary equipment. This resistance is characterised by its low value, around tenths of micro-ohms. The only way to measure them is via the 4-wire measurement, which consists of injecting a current of sufficient value so as to generate sufficient voltage drop to be measured with certain accuracy.

Dividing the voltage value obtained by the current value injected, we obtain the impedance (Z) of the cross-section between the two points where the voltage measurement

cables are connected.

However, for practical purposes, we are only interested in the real part (resistance R) of the total impedance, which is the result that we obtain from measuring in Alternating Current.

To obtain this real part, we must also measure the phase angle. This is the aim of the test template.

Template configuration:

The template is configured as follows:

- Generator: Pass-through turn

- Time display; As timer in seconds (8 s, maximum length of high current injection)
- V1 in input secondary voltage meter in Volts. Auto Mode (voltage drop between the points selected).
- Phase angle meter between voltage V1 in and primary current I_o.
- Power factor meter ($\cos(\varphi)$) between V1 and I_o.
- Impedance (Z) meter between the selected points.
- Real part (R) meter between the selected points.

Connections:

Connect the output of the pass-through turn to each side of the point selected to be measured.

Connect the tips of the test cable of input V1*, always between the previous current ones, never outside. The polarity does not matter.

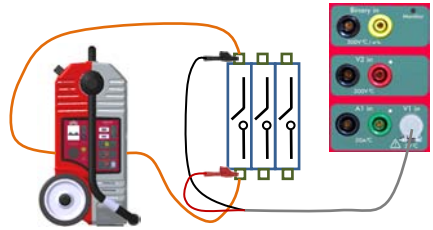

*The level of the measurement input V1 is very low so a cable with a special connector is used (supplied with the equipment) to shield the measurements well from possible electromagnetic noise. In ambients where there is loud noise, the tip of the YELLOW cable (Earth) must be connected to the earth of the system, or at least to the BLACK tip of the measurement cable.

Test:

Select and inject an adequate current value for the test*.

*In general, talking about contact resistances of circuit breakers and sectionalizers or busbar connection points, currents of around 500 A should be more than safe. In any case, and whenever possible, try to inject the maximum current that can be obtained from the system, without overloading the capacity of the point tested. The minimum current to carry out this test must be over 100 A to be able to obtain reliable results.

The timer will start up. When the countdown reaches zero, the injection will stop and the HOLD key will be activated, blocking all the measurements and ending the test.



If you find the default measurement time on the Template (8 s) short and you wish to increase it, do so, but bear in mind the cable cross-section used (the cable may overheat).

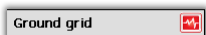

Ground grid



This template permits testing the integrity of the grids and earth taps within a sub-station or power plant.

It is very important to regularly check the integrity of the ground grid, and above all, of the connections from any earthed element, as the buried part may have corroded and this is impossible to detect unless it is done by injecting current of the highest possible value, so that this deterioration can really be detected. Being certain of the correct integrity of the ground/earth system is essential, as if one of these connections has deteriorated and an earth fault occurs, it may simply blow just like a fuse would, which may cause considerable damage to the protected

equipment.

Template configuration:

The template is configured as follows:

- Generator: Pass-through turn
- Time display: As timer in seconds (8 s, maximum length of high current injection)
- V1in input secondary voltage meter in V. Auto Mode (voltage drop between the points selected).

Connections:

Connect the pass-through turn(s) to the earth taps selected, where the current injection will be carried out. In general, one earth tap must be selected as reference and another as return. For example, the earth tap of the transformer and that of the circuit breaker.

The currents required for this test do not have to be very high, but the cables used must be long enough to take the current to points that are relatively far away.

The cable cross-section chosen will have to be about 40 or 50 mm, winding 10 turns in the equipment (C15 configuration at least will always be necessary for this type of tests), for example, to reach significant distances of around 20 or 25 meters between test points. Use quite a short cable to wind the turns and connect supplementary cable to their outputs to reach the required distance.

Place the equipment close to one of the earth taps and extend only one of the ends, above all the voltage measurement cable.

Connect the tips of the test cable of voltage measurement input V1*, in the tested earth taps. The polarity does not matter.

Due to the distance between the two test points, the supplementary measurement cable that you will have to use for at least one of the test points will be long. To avoid noises, you must use a shielded cable which shield must be connected to the YELLOW tip of the equipment test cable.

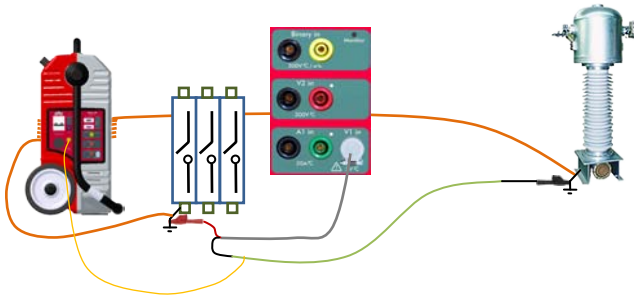

* The level of the measurement input V1 is very low so a cable with a special connector is used (supplied with the equipment) to shield the measurements well from possible electromagnetic noise. In ambients where there is loud noise, the tip of the YELLOW cable (Earth) must be connected to the earth of the system, or at least to the BLACK tip of the measurement cable.

Test:

Select and inject 300 A current. Maintain the current for a few minutes to give time for any possible fault point to open, if this is the case.

Stop the current injection and test by clicking on the button of the dial.

The voltage measured by the Display V1 must be divided between the meters that separate the two earth taps to be tested. If the result is more than the value of 0.1 V/m, this indicates a problem in the ground grid.

If the 300 A current cannot be reached, or it can be exceeded with your configuration, convert your criterion into V/m that can be reached according to the following formula:

$$I_{test} * 0.1 / 300$$

Carry out this test with the highest possible injected current (always bearing in mind the capacity of the test cable). Thus it will be closer to the reality of the values that can be reached in an earth fault.



CT Burden



This template enables us to determine, very accurately, the burden that is connected in the secondary of a CT. Accurate knowledge of this value as well as of its power factor is very important to determine if the CT is suitable or not for this burden. This information must be used together with the nominal power of the CT and its magnetisation curve.

Template configuration:

The template is configured as follows:

- Generator: Auxiliary power output. Current Mode
- Time display: As chronometer in seconds. Stop mode: Push on dial
- A1in input current meter in Amps. Auto Mode (Injected test current).
- V2in input voltage meter in Volts. Auto Mode (voltage required by the burden).
- Phase angle meter between voltage measured in V2in and the test current measured in A1in.
- Apparent power (S) meter in VA
- Power factor meter ($\cos(\phi)$) of the burden.
- Impedance (Z) meter of the burden in ohms.

Connections:

The Auxiliary Power Output Generator is used in current mode, not the pass-through turn generator, to carry out this test, as the current needed to be injected into the burden is the nominal secondary current of the CT, that is, either 1 A or 5 A.



Warning – It is very important for you to make sure that the pass-through turn generator has no burden of any kind, either by extracting the cable from the inside, if there is one, or making sure that the turn is open, with no possibility of accidental closure.

For this test to offer you correct results, it is important not to leave any burden not measured, so you must proceed to lift one of the CT secondary physical connections from the bushing plate of the actual transformer. Proceed with caution when carrying out this operation, making very sure that no primary current passes through the CT. Although the test does not require much time, it is very advisable, after lifting both cables from the CT bushing plate, to make a bridge between these bushings with a cable so that, if for any reason the CT receives current in its primary, its secondary is always short-circuited.

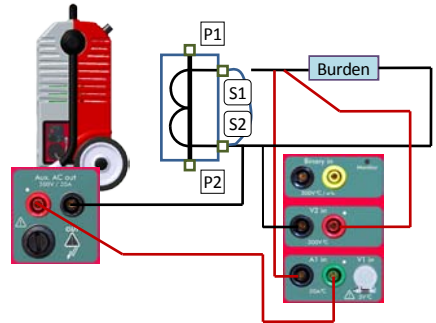

Once the secondary connection cables are available, connect as follows:

1. Connect the BLACK tap of the auxiliary output of the RAPTOR, using a test cable, to the connection cable of the secondary corresponding to S2. Make sure that they are firmly connected together.
2. Connect the RED tap of the auxiliary output of the RAPTOR, using a test cable, directly to the GREEN tap of the current measurement input A1 of the actual equipment.
3. Connect the BLACK tap of the current measurement input A1 of the equipment, using a test cable, to the connection cable of the secondary corresponding to S1. Make sure that they are firmly connected together.
4. Connect the RED tap of the voltage measurement input V2 of the equipment to the connection cable of the secondary corresponding to S1, making sure that it is connected downstream from the current injection connection*.
5. Connect the BLACK tap of the voltage measurement input V2 of the equipment to the connection cable of the secondary corresponding to S2, making sure that it is connected upstream from the current connection*.

* This is a 4-wire measurement. If you connect the voltage measurement cables incorrectly, you may include in it the impedance measurement of the actual test connection, which is not desirable.

Test:

Select and inject the right current value for the test, depending on the nominal secondary current value of the CT (1 or 5A)

The chronometer will start up and it will be possible to see the test results on the meter display. When you consider it appropriate, and by clicking on the dial, the injection will stop, the HOLD key will be activated, blocking all the measurements and ending the test. As nominal current is being injected, there is no heating risk for the burden or for the test cables of the equipment.

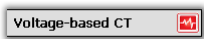

Voltage-based CT

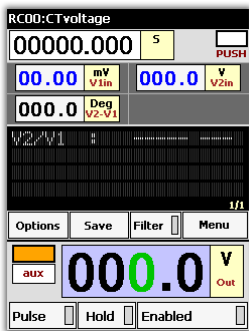

Sometimes, there are circumstances that prevent carrying out a ratio test on a CT properly, using current injection.

For example, a CT with very high primary current and which, due to its location, requires very long connection cables, thus preventing reaching sufficient current to carry out a reliable ratio measurement.

Another typical case is that of CTs situated directly in the high voltage bushings of power transformers, which, in many cases, do not have an auxiliary primary connection to allow to directly inject into the CT, so that it is impossible to inject this current as it would have to pass through the

power windings of the transformer.

In these cases, and as an alternative, this template can be used, thus enabling us to know the CT turn ratio and its polarity, testing it as if it were a voltage transformer.

This method obviously offers no information about the influence of the magnetic core on the total accuracy at its precision load.

Template configuration:

The template is configured as follows:

- Generator: Auxiliary power output. Voltage Mode
- Time display: As chronometer in seconds. Stop mode: Push on dial
- V1 in input voltage meter in mVolts. Auto Mode (Voltage measurement in primary of CT).
- V2in input voltage meter in Volts. Auto Mode (voltage measurement in CT secondary).

- Phase angle meter between voltage measured in V1in and the voltage measured in V2in. (Primary to secondary phase angle and polarity in degrees)
- V2/V1 ratio meter which is shown as a result of the division between the two voltages.

Connections:

The Auxiliary Output Power Generator is used in voltage mode to carry out this test, feeding the CT secondary, and the induced voltage is measured in the primary.

Connect as follows:

1. Connect the BLACK bushing of the Auxiliary Output to point S2 of the CT.
2. Connect the RED bushing of the Auxiliary Output to bushing S1 of the CT.
3. Connect the BLACK bushing of the voltage measurement input V2 to point S2 of the CT.
4. Connect the RED bushing of the voltage measurement input V2 to point S1 of the CT.
5. Connect point P1 of the CT to the RED tap of the voltage measurement input V1*.
6. Connect point P2 of the CT to the BLACK tap of the voltage measurement input V1*.

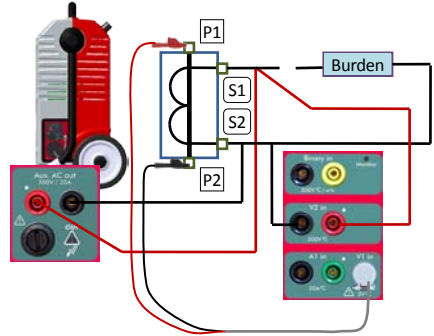

Warning – It is very important for you to make sure that the pass-through turn generator has no burden of any kind, either by extracting the cable from the inside, if there is one, or making sure that the turn is open, with no possibility of accidental closure.



* The level of the measurement input V1 is very low so a cable with a special connector is used (supplied with the equipment) to shield the measurements well from possible electromagnetic noise. In ambients where there is loud noise, the tip of the YELLOW cable (Earth) must be connected to the earth of the system, or at least to the BLACK tip of the measurement cable.

Test:

Select and inject the adequate test voltage level.

It is advisable to inject the maximum voltage value considered to be safe for the insulation of the secondary winding of the transformer on one side, and that is not going to exceed the value in primary of 3 V, which is the maximum value that input V1in can measure.

To determine the maximum injection voltage, the following arithmetic operation must be carried out:

$$V \text{ of maximum injection} = (\text{Nominal primary of CT in A} / \text{Nominal secondary of CT in A}) * 3$$

The maximum voltage that can be obtained from the Auxiliary Output of the equipment is 230 V, which should not present any risks for any secondary winding due to insulation.

It will be possible to read the ratio value V2/V1 during the injection, as well as the phase angle value (polarity), which should be zero or very close to this value.

If the measurements are seen to be unstable, and their values are continuously changing, use the FILTER option to see the most stable values.

To stop the injection and finish the test, simply click on the button of the dial.

Volt. transformer (VT) 

Volt. Transformer (VT)

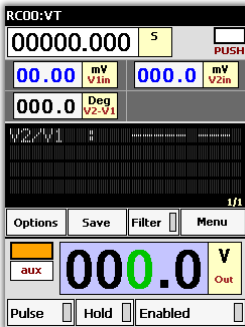

This template is designed to determine the transformation ratio in voltage measurement transformers, their primary/secondary phase angle and their polarity. The normal denomination of these transformers is usually VT or also PT, although the latter could be confused with Power Transformer.

Regardless of their nominal primary value in kV, these transformers have three standard nominal secondary values, 100 V, 110 V or 120 V.

This means that their transformation ratios are, as a general rule, very high; for example, a primary rate VT of 132 kV and secondary of 110V has a ratio of 1200, which means that if we inject the maximum voltage of the 230 V auxiliary output through primary, we will obtain a voltage in secondary of $230 / 1200 = 0.192 \text{ V}$, which can be measured perfectly through measurement input V1.

Template configuration:

The template is configured as follows:

- Generator: Auxiliary power output. Voltage Mode
- Time display: As chronometer in seconds. Stop mode: Push on dial
- V1in input voltage meter in mVolts. Auto Mode (Voltage measurement in secondary of VT).
- V2in input voltage meter in Volts. Auto Mode (voltage measurement in primary of VT).
- Phase angle meter between voltage measured in V1in and the voltage measured in V2in. (Secondary to primary phase angle and polarity in degrees)
- V2/V1 ratio meter which is shown as a result of the division between the two voltages.

Connections:

The Auxiliary Output Power Generator is used in voltage mode to carry out this test, feeding the VT primary, and the induced voltage is measured in the secondary.

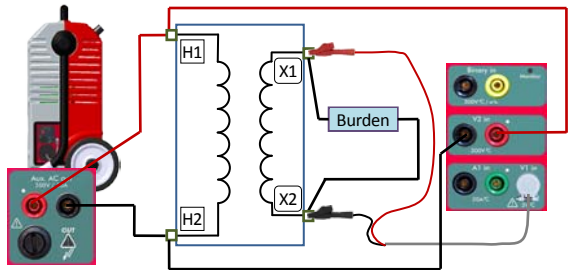

Connect as follows:

1. Connect the RED bushing of the Auxiliary Output to point P1 of the VT.
2. Connect the BLACK bushing of the Auxiliary Output to bushing P2 of the VT.
3. Connect the RED bushing of the voltage measurement input V2 to point P1 of the VT.
4. Connect the BLACK bushing of the voltage measurement input V2 to point P2 of the VT.
5. Connect point S1 of the VT to the RED bushing of the voltage measurement input V1*.
6. Connect point S2 of the VT to the BLACK bushing of the voltage measurement input V1*.



Warning – It is very important for you to make sure that the pass-through turn generator has no burden of any kind, either by extracting the cable from the inside, if there is one, or making sure that the turn is open, with no possibility of accidental closure.



* The level of the measurement input V1 is very low so a cable with a special connector is used (supplied with the equipment) to shield the measurements well from possible electromagnetic noise. In ambients where there is loud noise, the tip of the YELLOW cable (Earth) must be connected to the earth of the system, or at least to the BLACK tip of the measurement cable.

Test:

Select and inject the adequate test voltage level.

It is advisable to inject the maximum voltage value that the equipment is able to provide (230 V) to be at the highest possible point of the nominal primary of the VT.

It will be possible to read the ratio value V2/V1 during the injection, as well as the phase angle value (polarity), which should be zero or very close to this value*.

If the measurements are seen to be unstable, and their values are continuously changing, use the FILTER option to see the most stable values.

To stop the injection and finish the test, simply click on the button of the dial.

*The results obtained with this test are exact, but as a very low percentage of Nominal Primary Voltage of the VT is being injected, the errors that the transformer produces may be high, both with respect to the ratio and to phase angle. The analysis of where it is or is not in accordance with what is expected in nominal conditions must be carried out by the user, bearing this circumstance in mind.

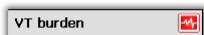

VT Burden

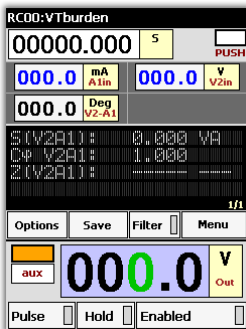

The VTs define their precision class related to a specific burden called “precision burden”. It is important to know the real burden that is connected to the VT both in amplitude and in power factor, and to compare this with the nominal precision power of VT and thus determine if it is adequate for the position it occupies.

This template helps measure this burden.

Template configuration:

The template is configured as follows:

- Generator: Auxiliary power output. Voltage Mode
- Time display: As chronometer in seconds. Stop mode: Push on dial
- V2in input voltage meter in Volts. Auto Mode (voltage measurement injected into the burden).
- A1in input current meter in Amps. Auto Mode (Current measurement in burden).
- Phase angle meter between current measured in A1in and the voltage measured in V2in. (Burden phase angle and polarity in degrees)
- Apparent power (S) meter in VA
- Power factor meter ($\cos(\varphi)$) of the burden.
- Impedance (Z) meter of the burden in ohms.

Connections:

The Auxiliary Output Power Generator is used in voltage mode to carry out this test, feeding the burden connected to the secondary burden of the VT and measuring the current it consumes.

The connection cables must be disconnected from the VT secondary, taking the appropriate precautions, thus insulating this secondary. The injection of the test voltage will be carried out on these cables.

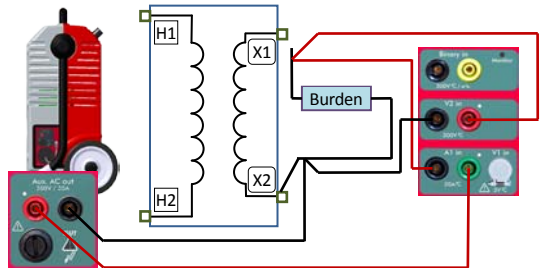

Connect as follows:

1. Remove connection from secondary H1
2. Connect the BLACK bushing of the Auxiliary Output to the cable that was connected at point H2 of the VT.
3. Connect the RED bushing of the Auxiliary Output to the GREEN bushing of the current measurement input A1.
4. Connect the BLACK bushing of the current measurement input A1 to the cable that was connected at point H1 of the VT.
5. Connect the RED bushing of the voltage measurement input V2 to the cable that was connected at point H1 of the VT.

6. Connect the BLACK bushing of the voltage measurement input V2 to the cable that is connected at point H2 of the VT.



Warning – It is very important for you to make sure that the pass-through turn generator has no burden of any kind, either by extracting the cable from the inside, if there is one, or making sure that the turn is open, with no possibility of accidental closure.

Test:

Select and inject the adequate test voltage level.

The voltage that must be selected is the one that corresponds to nominal secondary of the VT. With very rare exceptions, this will be 100 V, 110 V or 120V. The template uses the voltage value measured through input V2 for all its calculations, but this measurement may not be identical to the selected injection value, as the auxiliary power output is regulated in the primary winding of the internal output transformer of the equipment. Consequently, and depending on the burden value, a small error may occur at its real output, due to the fact that we are connecting it in the secondary. If you wish to exactly inject the nominal value, adjust the selection with the dial until you read this nominal value on the relative meter.

You will be able to read all the values indicated by the meters during the injection.

If the measurements are seen to be unstable, and their values are continuously changing, use the FILTER option to see the most stable values.

To stop the injection and finish the test, simply click on the button of the dial.



Short-circuited PT

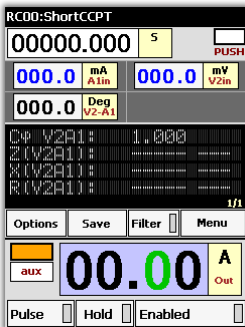

This template is designed to carry out short-circuited impedance tests in any Power (PT) or Distribution Transformer.

This test provides a lot of information about the state of the internal geometry of the PT, detecting possible movements of the internal windings due to transport or to a very severe fault, by comparing the results obtained in each winding. These must be reasonably balanced.

The Short-circuited Voltage percentage ($V_{cc}\%$) or the same percentage defined in Impedance ($Z\%$) may also be calculated. These are the two ways in which this

information can appear on the technical characteristics plate of the PT. The definition of the Short-circuited voltage is:

Voltage expressed in % of the nominal primary voltage (High), necessary to obtain the nominal primary current of the transformer, with the secondary side (Low) short-circuited.

Several tests are required, one per winding, on the one hand, to calculate these parameters, as well as an adequate calculation later on, using the results obtained in each one of them, and also considering the nominal technical characteristics of the PT (which are on the transformer plate) with respect to transformation ratio, connection group, short-circuit impedance (or voltage) in % of nominal, nominal primary voltage or High winding, and nominal secondary voltage or Low winding.

Template configuration:

The template is configured as follows:

- Generator: Auxiliary power output. Voltage Mode
- Time display: As chronometer in seconds. Stop mode: Push on dial
- V2in input voltage meter in Volts. Auto Mode (voltage measurement injected into High winding).
- A1in input current meter in Amps. Auto Mode (Current measurement in High winding, in this case short-circuited).
- Phase angle meter between current measured in A1in and the voltage measured in V2in. (Phase angle between short-circuited current and injected voltage).
- Power factor meter ($\cos(\varphi)$) of the short-circuited transformer.
- Impedance (Z) meter of the short-circuited transformer in ohms.
- Reactive component meter of Z (X) in ohms.
- Real component meter of Z (R) in ohms.

Connections:

The Auxiliary Output Power Generator is used in voltage mode to carry out this test, feeding between two phases of the High side of the PT and measuring the current it consumes.

The bushings corresponding to the two phases that are injected are short-circuited in the LOW side of the PT. It is very important for the connection cables and devices to the PT bushings to have a large cross-section, as very high currents can be produced in the short-circuit.

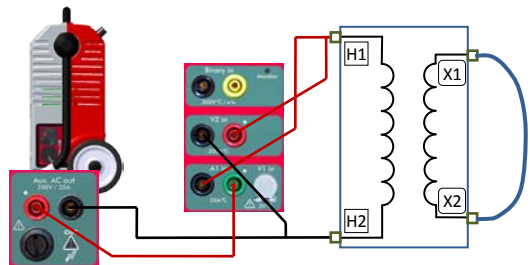

Connect as follows (the connection between phases H1 and H2 is described, repeat this connection for phases H2H3 and for H3H1):

1. Connect the BLACK bushing of the Auxiliary Output to H2 of the PT.
2. Connect the RED bushing of the Auxiliary Output to the GREEN bushing of the current measurement input A1.
3. Connect the BLACK bushing of the current measurement input A1 to H1 of the PT.
4. Connect the RED bushing of the voltage measurement input V2 to H1 of the PT.
5. Connect the BLACK bushing of the voltage measurement input V2 to H2 of the PT.
6. Short-circuit the bushings the Low side of the PT, X1 and X2, with adequate cables.



Warning – It is very important for you to make sure that the pass-through turn generator has no burden of any kind, either by extracting the cable from the inside, if there is one, or making sure that the turn is open, with no possibility of accidental closure.

Test:

First of all, you must calculate the equivalent value at reduced voltage of the nominal current of the PT. Use the following formula:

$$P_n/V_n = I_{nom} \text{ of the PT}$$

Where: P_n is the Nominal Power of the PT in kVA, V_n is the nominal primary voltage in kV of the PT and I_{nom} is the nominal current of the PT in Amperes.

Now calculate the value of the Short-circuited voltage:

$$(V_n * V_{cc}\%/100) * 1000 = V_{cc} \text{ in volts.}$$

Where: V_n is the nominal primary voltage in kV of the PT, $V_{cc}\%$ is the value on characteristics plate of the short-circuited impedance in %.

Calculate the respective value of reduced voltage according to availability of equipment (9 A and 230 V max) in permanent:

$$V_{ccr} = V_{cc} * I_{red}/I_{nom}$$

Where: V_{cc} is the short-circuited voltage in Volts, I_{nom} is the nominal current of the transformer in Amperes and I_{red} is the reduced current that is going to be used, which must be less or equal to 9 A (permanent max. of the auxiliary output of the equipment). Start by setting a value at I_{red} of 9 A.

The V_{ccr} value obtained must be lower than the available in the equipment, 230 V. If it is higher, replace I_{red} of the formula with a lower value until the V_{ccr} value is less than 230 V.

Once you know these values, connect the equipment output and gently adjust the output voltage until you obtain the value READ on display V2, equal to V_{cc} . If the real short-circuited impedance coincides with the theoretic impedance, you should be reading a current value on display A1 that is very similar to I_{red} .

You will be able to read all the values indicated by the meters during the injection.

If the measurements are seen to be unstable, and their values are continuously changing, use the FILTER option to see the most stable values.

To stop the injection and finish the test, simply click on the button of the dial.

Save the results with a comment, indicating that this is the measurement H1H2 and repeat the process with the remaining phase loops.

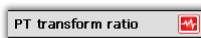

PT ratio

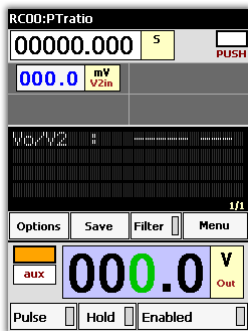

This template permits measuring the voltage ratio between the primary or High winding and the relative secondary or Low winding of a Power (PT) or Distribution Transformer.

However, unless the transformer is single-phase or three-phase with connection group YNyn..., this voltage ratio will not coincide with the transformation ratio that appears on the characteristics plate of the PT.

To convert the voltage ratio measured at this transformation ratio, several calculations are required, as well as the execution of tests with different connections to the PT. These calculations and connections depend on the PT group, and as there are many different ones, they are not described in this Handbook, and are left to the discretion of the equipment operator.

If this calculation method is required, please contact us and we will give it to you.

Template configuration:

The template is configured as follows:

- Generator: Auxiliary power output. Voltage Mode
- Time display: As chronometer in seconds. Stop mode: Push on dial
- V2in input voltage meter in Volts. Auto Mode (voltage measurement in Low voltage winding).
- Voltage ratio meter V_o/V_2

Connections:

The Auxiliary Output Power Generator is used in voltage mode to carry out this test, feeding between two phases or between phase and neutral, as possible, the High side of the PT.

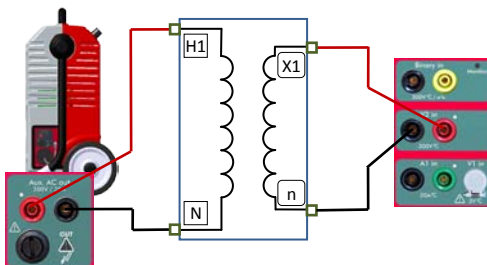

The relative voltage is measured between the two bushings of the PT corresponding to the same phases on the Low side, which are being injected from the High side.



DANGER – Make sure that you are connecting the Auxiliary Generator of the equipment to the High side. Never connect it on the Low side, because very dangerous voltages may occur on the High side, if this happens.

In general, and assuming that a PT with neutral accessible in both windings is being tested, connect as follows:

1. Connect the BLACK bushing of the auxiliary equipment of the equipment to bushing N of the High side of the PT.
2. Connect the RED bushing of the auxiliary equipment of the equipment to bushing H1 of the High side of the PT.
3. Connect bushing n of the Low side of the PT to the BLACK bushing of the V2in measurement input of the equipment.
4. Connect bushing X1 of the Low side of the PT to the RED bushing of the V2in measurement input of the equipment.

If the PT is three-phase, you must carry out a measurement in each phase. If the neutral is not accessible in either of the two windings, you must inject between two phases (H1H2) and measure on the Low side in agreement with the calculation and connection diagram required, depending on the PT connection group.



Warning – It is very important for you to make sure that the pass-through turn generator has no burden of any kind, either by extracting the cable from the inside, if there is one, or making sure that the turn is open, with no possibility of accidental closure.

Test:

Connect the equipment output and gently adjust the output voltage until it is as high as possible (max. 230 V).

You will be able to read all the values indicated by the meters during the injection.

If the measurements are seen to be unstable, and their values are continuously changing, use the FILTER option to see the most stable values.

To stop the injection and finish the test, simply click on the button of the dial.

Save the results with a comment, indicating that this is the measurement H1N/X1n, or the couple of phases you are using, and repeat the process with the remaining phase loops.

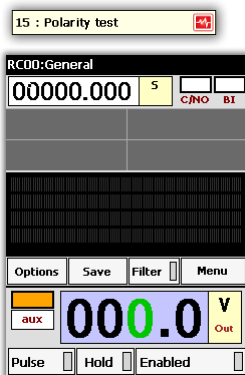

Polarity test

The *Polarity Test* template is very similar to the *General Template*, where you can basically adjust and operate any of the Raptor's outputs.

However, when the *Polarity Test* template is selected, the Raptor will be set to produce an asymmetrical waveform in order to allow the *Polarity Tester* probe to easily determine the direction of the current flow between any two connections within the same circuit.

This *polarized* mode is indicated next to the output level window by a symbol like "+~-".

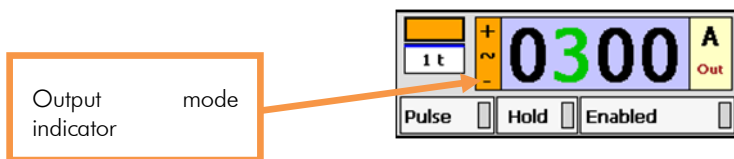

16 : HV dielectric

Dielectric strength with HV



This template is only available for the Raptor CV-X5 systems (with Raptor HV case). On the contrary, when it is selected, a message appears indicating this condition and not allowing it to be selected.



This template is used to submit the insulation of a transformer to strain, at a much higher level that it would be at during normal operation. A high voltage level is applied for a specific time interval (with the output of the Raptor HV case) to check the integrity of the insulation by controlling the resulting leakage current. The voltage is applied either between the primary winding and the secondary winding, or between the secondary winding and earth.

The leakage current is the current that is filtered through the product insulation system. The insulation fault is a disruptive discharge through the entire insulation system that produces a large sudden increase in current through the insulation. To configure the “trip point” of the leakage current, the stop condition due to “Ah overcurrent” is established, with a default value of 10 mA.

Dielectric strength test between primary and secondary.

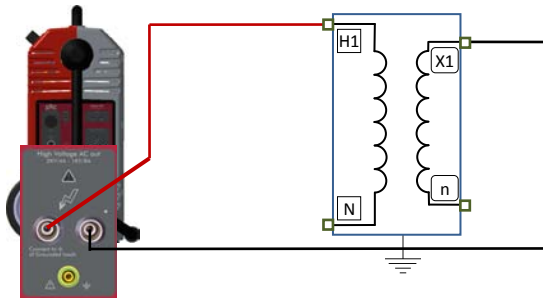

Connect as follows for this test:

1. Connect the BLACK terminal of the output of the Raptor HV unit to terminal X1 of the low side of the transformer.
2. Connect the RED terminal of the auxiliary output of the equipment to terminal H1 of the High side of the transformer.

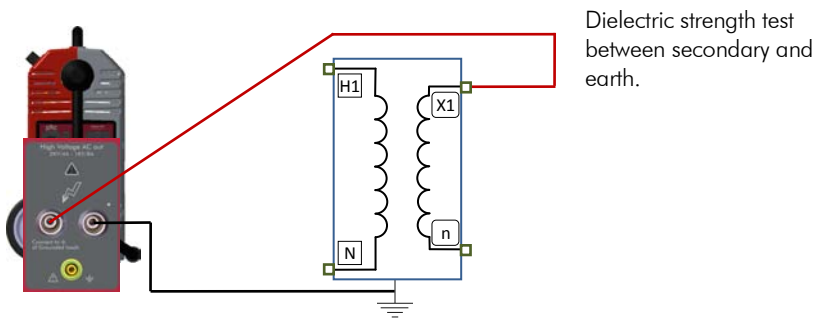

Connect as follows for the test between earth and secondary winding:

1. Connect the BLACK terminal of the output of the Raptor HV unit to the earth connection of the transformer.
2. Connect the RED terminal of the output of the Raptor HV unit to terminal X1 of the Low side of the transformer.

Configuration:

The template is configured as follows:

- Generator: Output by secondary HV.
- Time display: Countdown, in seconds. By default, 60 s.
- Stop mode: Due to A_{hv} overcurrent. Default value, 10 mA
- A_{hv} current meter in Automatic Mode. The peak value for possible stoppage due to momentary peak is displayed.
- Phase angle meter between A_{hv} and V_{hv} voltage (output voltage).
- Impedance meter (Z) in ohms.
- Reactance meter (X) in ohms.
- Resistance meter (R) in ohms.
- Power factor meter ($\cos(\varphi)$) between A_{hv} and V_{hv} .

Test:

Select and inject a low test voltage level. Then, gradually increase the level until the trip/stoppage occurs due to reaching the configured current value. The test also ends when the time established in the countdown has been completed.

If you observe that the measurements are unstable, and the values are continuously changing, use the FILTER option to see the most stable values.

To stop the injection and interrupt the test, *click* on the rotating control button.



Voltage transformer with HV



This template is only available for the Raptor CV-X5 systems (with Raptor HV case). On the contrary, when it is selected, a message appears indicating this condition.



This template is designed, using the high output voltage of the Raptor HV case, to determine the transformation ratio in voltage measuring transformers, its primary/secondary phase angle and its polarity. Furthermore, it permits knowing the real load connected to the TV both in module and in power factor to compare this with the rated precision power of the TV and thus determine if it is adequate for the position it occupies.

The template is configured as follows:

- Generator: Output by secondary HV.
- Time display: Chronometer, in seconds.
- Stop mode: Press/push the rotating control push
- *A1in* current meter in Automatic Mode.
- *V2in* voltage meter in Automatic Mode.
- Phase angle meter between *V2in* and the *A1in* current.

- Phase angle meter between $V2in$ and the V_{hv} output.
- Apparent power (S) meter in VA.
- Impedance meter (Z) in ohms.
- Power factor meter ($\cos(\phi)$) between $V2in$ and $A1in$.
- Transformation ratio given by $V_{hv}/V2in$.

Test:

Select and inject the right test voltage level.

It is advisable to inject the maximum voltage value that the equipment can provide (2000 V) to reach the highest point possible of the rated value of the TV primary. This leads to less errors in the values measured.

During the injection, the $V2/V1$ ratio value and the phase angle value (polarity), which should be zero or very close to this value, can be read.

If you observe that the measurements are unstable, and the values are continuously changing, use the FILTER option to see the most stable values.

To stop the injection and end the test, just *click* on the rotating control button.

18 : HV no-load PT 

No-load PT with HV



This template is only available for the Raptor CV-X5 systems (with Raptor HV case). On the contrary, when it is selected, a message appears indicating this condition.

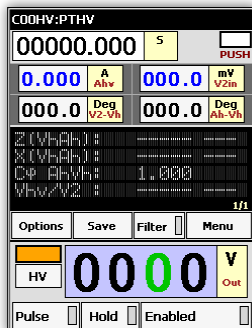

This template permits measuring the voltage ratio between the primary winding or High and the respective secondary winding or Low of a Power or Distribution Transformer (PT). This test uses the high voltage output of the Raptor HV case to obtain higher voltage values in the ratio and minimise errors.

Likewise, it informs us of the magnetisation current (A_{hv} meter).

Connections:

To carry out this test, the Raptor HV output is used, supplying between two phases or between phase and neutral, whichever is possible, the High side of the PT.

The respective voltage is measured between the two terminals of the PT corresponding to the same phases on the Low side that are being injected from the High side.

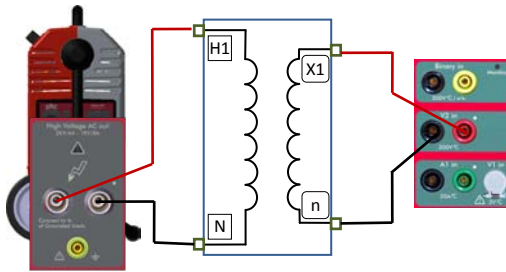

Danger – Make sure you are connecting the equipment power output to the High side. Never connect it to the Low side because very dangerous voltages can occur on the High side if this occurs.

Template configuration:

The template is configured as follows:

- Generator: Raptor HV power high voltage output.
- Time display: As chronometer in seconds. Stop mode: Press/push rotating control
- Voltage meter *V2in* input in Auto Mode A.
- Voltage meter *Vhv* input in Auto Mode V. (measurement of voltage in Low winding).
- Phase angle meter between *V2in* and *Vhv*.
- Phase angle meter between *Ahv* and *Vhv*.
- Magnetisation impedance measurement Z.
- Magnetisation reactance measurement X.
- Power factor measurement ($\cos(\varphi)$) between *Ahv* and *Vhv*.

- Voltage ratio meter V_{hv}/V_{2in} .

Test:

Select and inject the right test voltage level.

It is advisable to inject the maximum voltage value that the equipment is able to provide to reach the highest point possible of the rated value of the PT primary, providing that this does not cause a very high magnetisation current, above the magnetic saturation knee point. This leads to fewer errors in the values measured.

During the injection, the V_{hv}/V_{2in} ratio value and the phase angle value (polarity), which should be zero or very close to this value. Likewise, the calculated parameters Z, X and $\cos(\varphi)$ referring to the magnetisation current, are shown.

19 : HV PT short circuit 

PT short circuit with HV



This template is only available for the Raptor CV-X5 systems (with Raptor HV case). On the contrary, when it is selected, a message appears indicating this condition.

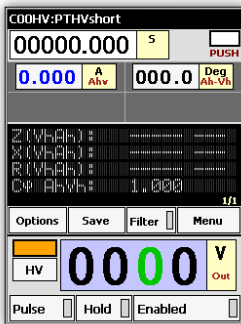

This template is designed to carry out the short circuit impedance tests in any Power Transformer (PT) or Distribution Transformer.

This test gives a lot of information about the state of the internal geometry of the PT, detecting possible movements of the internal windings due to transport or very strong fault, by comparing the results obtained in each winding. These must be reasonably balanced.

For more details about the purpose of the test, refer to the template on short circuited PT by auxiliary output.

Connections:

To carry out this test, the output of the Raptor HV case is used, supplying between two phases of the High side of the PT, short-circuiting the secondary, and measuring the current consumed.

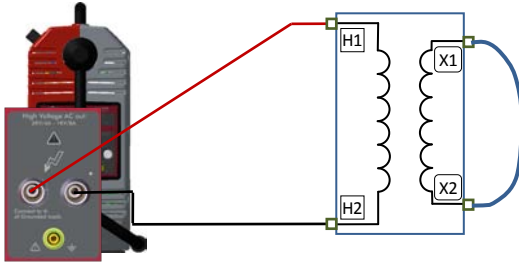

Danger – Make sure you are connecting the equipment power output to the High side. Never connect it to the Low side because very dangerous voltages can occur on the High side if this occurs.

Template configuration:

The template is configured as follows:

- Generator: Raptor HV power high voltage output.
- Time display: As chronometer in seconds. Stop mode: Press/push rotating control
- Current meter of A_{hv} in Automatic Mode A.
- Phase angle meter between A_{hv} and V_{hv} .
- Short circuit measurement Z.
- Short circuit reactance measurement X.
- Short circuit resistance measurement R.
- Power factor measurement ($\cos(\varphi)$) between A_{hv} and V_{hv} .

Test:

Short circuit the secondary winding (on the Low side). Select and inject the right test voltage level.

During injection, the meters will display the current values and the gap between the current and voltage generated. Likewise, the calculated parameters Z, X, R and $\cos(\varphi)$ referring to the short circuit impedance, are shown.

SPECIAL FUNCTIONS

The templates described above only generate a suitable configuration for a certain test. Apart from giving a configuration, the functions also carry out more complicated tests where the generation or stoppage values vary with time in a totally automated process.

To access the functions:



It has the following functions:

- *Re-coupler.*
- TC magnetisation
- Pulse train
- Pulse ramp
- Magnetisation with HV
- Step and touch voltage

Recloser.



This function is designed to verify, in a very simple manner, the correct operation of an integrated RECLOSER; that is, a device that include the MV circuit breaker, the protection CTs, the protection relay with recloser function and the total control of the system. These devices are found more and more frequently in Medium Voltage Distribution circuits.

The results shown include trip time and reclosing time (dead time) of each one of the reclosing cycles that the device actually carries out.

It does not require any type of configuration by the operator, although he must take into account that the maximum time this test lasts is set, by default, at 8 seconds. This time should be sufficient for the majority of the cases, but the operator must decide if it should be longer or shorter, editing it if required. The function will be left with the last length of time assigned. If you wish, you can configure the test for it to end by binary input or by intervention of the operator, instead of by time.

The trip times are represented as T and the reclose times as R.

Function configuration:

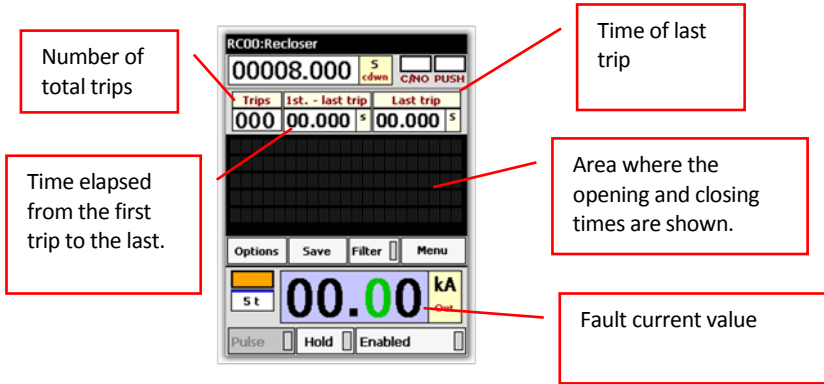

Connections

Connect the output of the Pass-through Turn Generator to the input and output of the Circuit Breaker of the recloser. This can be done in one single pole or in the three poles connected together in series.

Test:

Set a higher output current value than the trip set value in the over current element of the protection integrated into the recloser, to ensure that it trips. After that, the function automatically detects the trips and the reclosing times due to the appearance and disappearance of current in the generator circuit, and the automatic opening and reclosing process must be continuously carried out by the device being tested.

The device keeps the function running until the maximum test time has elapsed (8 s by default) or the manual stop condition has been fulfilled (by default this is by pushbutton), if the relay has completed the number of retries that have been set.

It is recommendable to use the generation current measurement range that adapts better to the current level that is going to be injected.

CT Magnetisation



This function permits the application of an increasing voltage in the secondary, with the primary open, until the current transformer is saturated, showing the knee point. Whilst the process is being carried out, the current and voltage values are measured. As soon as the knee point is detected (in agreement with a certain criterion), it is displayed.

Knowing the knee point is very important in all CTs, whether they are measurement or protection CTs, but especially in the latter as if there is a fault in the system, the primary current increases a great deal more than the nominal current, and it is essential for the CT to be able to produce the necessary voltage in its secondary bushings to maintain the consistency of its transformation ratio, so that the protection devices receive real information about what is occurring on the primary side. As the CT burden remains constant (although there are protection devices with saturable inputs whose impedance varies with the current) and the current increases a great deal, the voltage required to maintain the ratio also rises a great deal above that defined in its nominal power.

There are different Standards to define the knee point. As usual, there is an IEC standard, commonly used all over the world, and the ANSI standard* that even contains two definitions of knee point. In any case, the three standards define very similar value points.

This function uses the IEC criterion to calculate and show the Knee point. This criterion is defined as: *"Point at which a 10% increase in voltage over the previous value causes a 50% increase in current over the previous value"*

* The ANSI Standard is divided into two, the ANSI 30° and the ANSI 45°, and the criterion is defined as *"Point at which, on a graphical representation of I, logarithmic type on both axes, the slope of the tangent at the point reaches a value of 30° or of 45° depending on the Standard applied"*.

Function configuration

This is shown on the image below:

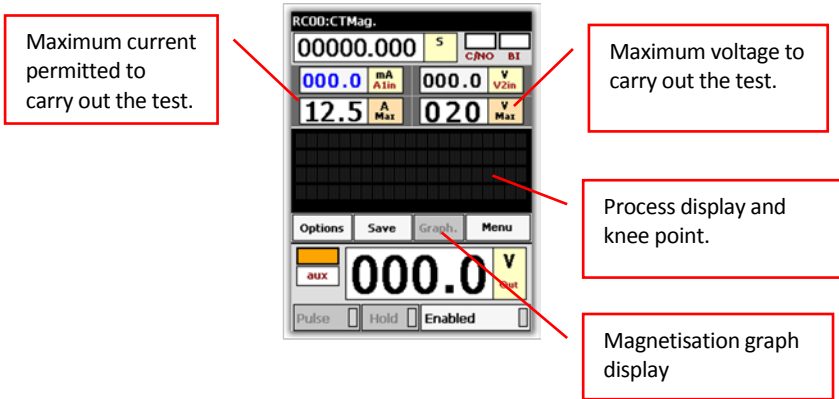

Connections

All the connection are made in the secondary winding (1 or 5 A) of the CT. The Primary winding must be left OPEN.

Connect the BLACK bushing of the Auxiliary Generator of the equipment to the bushing of the secondary of the CT, marked S1.

Connect the RED bushing of the Auxiliary Generator of the equipment to the GREEN bushing of the current measurement input A1in.

Connect the BLACK bushing of the current measurement input A1in to the bushing of the secondary of the CT marked S2.

Connect bushing S1 of the CT to the BLACK bushing of the voltage measurement input V2in.

Connect bushing S2 of the CT to the RED bushing of the voltage measurement input V2in.

Test

The function is automatic, so the operator only has to enter the maximum I and maximum V values into the relative controls, and simply click on the dial to start the test. If the knee point is found, this will be displayed on the screen. Do not interrupt the test as it has not finished. Always let the demagnetisation process end.

The maximum voltage value entered is especially important. If you enter a very high value with respect to the value that would really correspond to the CT tested, the knee point will be obtained, but with little resolution as the function calculates up to 40 increases with respect to the value entered (they could be too big). It would also be possible for it to be above the knee point with the first increase and then the test would not offer any result. If the value entered is smaller than the real value of the CT, it would not offer any result, either. It is advisable to enter a slightly higher value than expected in this parameter, if this is known. The level curve in V generated is not linear with time. Increases in V decrease as it approaches V_{max} . This improves the resolution in the area of interest.

The test consists of injecting a ramp of ascending voltage values up to 20% above the maximum voltage entered or a maximum of 40 pitches (logarithmic voltage increases). After the maximum test value has been reached, the CT is demagnetised, generating the same voltage points, in descending order and with a smaller time interval.

During the test, the injected voltage will increase every 2 seconds up to a maximum of 20% above the maximum value entered.

The test ends with a demagnetisation process, if the current measured or voltage measured exceeds the maximums entered, or the maximum voltage that the equipment can generate is reached.

The test can also be aborted by pressing (off). In this case, the CT is NOT demagnetised.

When the test ends, by tapping on the *Graph* button, it is possible to see the graph of the test points that make up the magnetisation curve and the position of the knee point, if it has been detected. The representation of the reference axes of the curve is logarithmic for the X-axis (I magnetisation), and linear for the Y-axis (V magnetisation).

Pulse train



The *Pulse train* function allows the injection of pulses by regular intervals. You can set the amplitude, duration and interval's length, as well as the used Raptor's output. Once started, the pulse train will continue until the countdown limit is reached or a stop condition is met.

Setting up the function

The following diagram illustrates the configuration buttons and the related indicators for the *Pulse train* function:

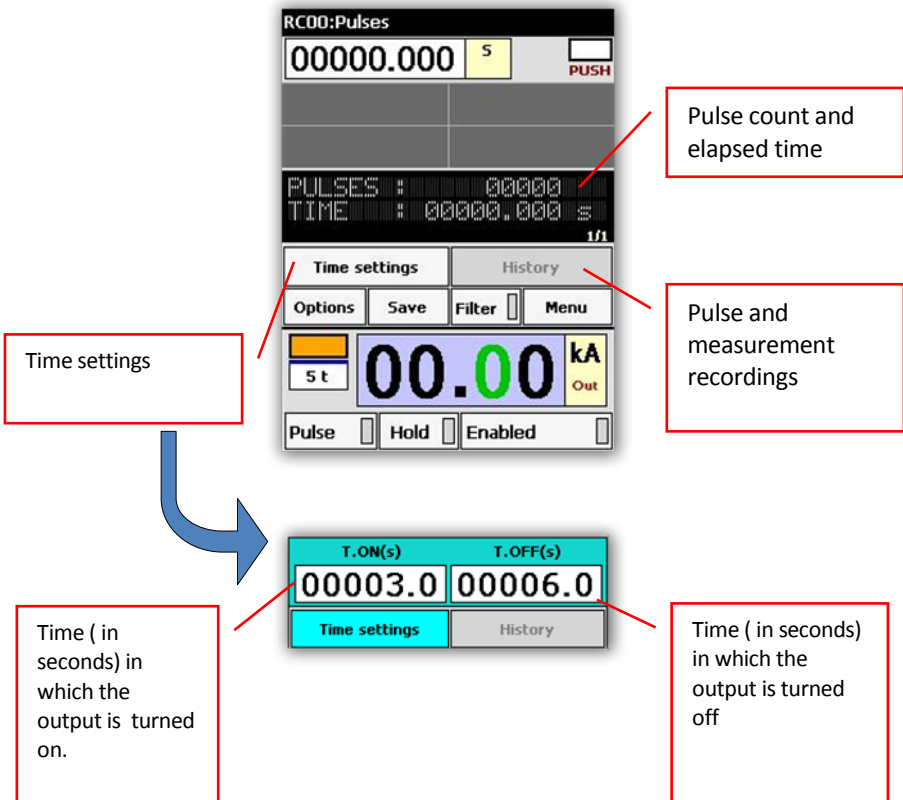

Pulse ramp.



This function permits intermittent generation at regular intervals, with a level at the output that increases or decreases from the initial level to the final level, varying by a defined value at each interval. The on time can be modified, as well as the time between pulses, but this cannot be less than 500 ms. Any output value can be selected and controlled, in any of the generators that the Raptor system possesses. The generation will end when the final value of the function is reached, a limit time is attained or a stop condition occurs. The default stop condition is by detection of zero current.

Function configuration:

This is shown in the picture below:

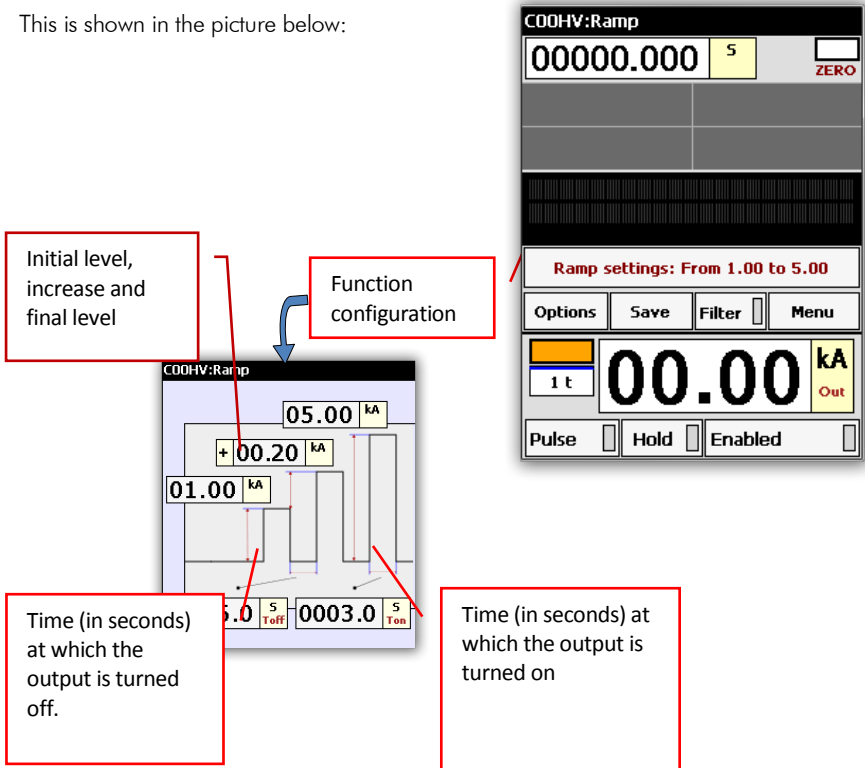

HV Magnetisation.



It can only be used in Raptor CV-X5 Systems (with Raptor HV case).



This function permits applying an increasing voltage in the secondary with the primary open, until the current transformer is saturated, showing the knee point. Whilst the process is being carried out, the current and voltage values are being measured. When the knee value is detected (in agreement with a determined criterion), this is shown on screen. This test takes advantage of the high power output of the Raptor HV unit.

Function configuration:

This is shown in the picture below:

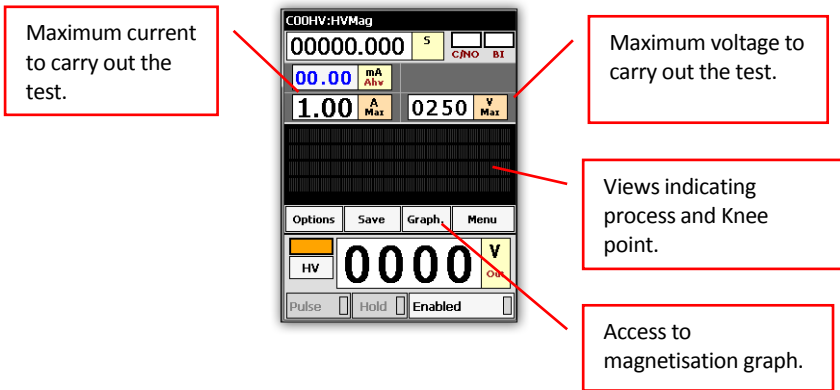

During the test, the voltage injected will increase every 2 seconds until it reaches a maximum of 20% over the maximum value entered.

If the current measured exceeds the maximum entered or reaches the maximum voltage that the equipment can generate, the test will end with a demagnetisation process.

The test can also be aborted by pushing (off) .In this case, the TC is **NOT** demagnetised. If a critical alarm goes off that turns the system off, the test will also be aborted and no demagnetisation will take place.

When the test ends, if the *Graph* button is pressed, the graph of the test points that make up the magnetisation curve and the position of the knee point, if detected, can be seen. The reference axes of the curve are represented as a logarithm for the x-axis (I magnetization) and linear for the Y-axis (V magnetisation).

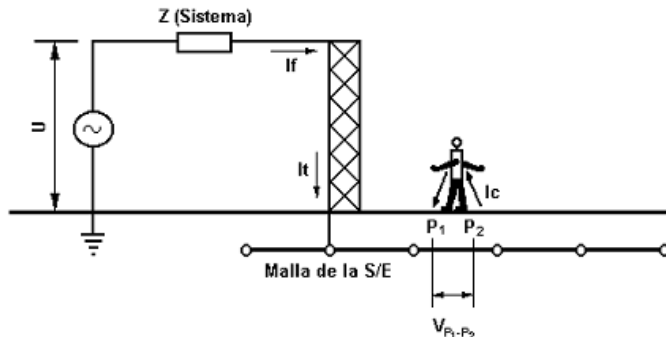

Where V_{p1-p2} is the step voltage to be measured.

Function configuration:

This function will also have the time display as countdown (by default, with a value of 20 seconds. Less time is not permitted). *It can only be generated through Raptor HV output and in the 1000 V level range.*

The main screen with the function can be seen in the picture below:

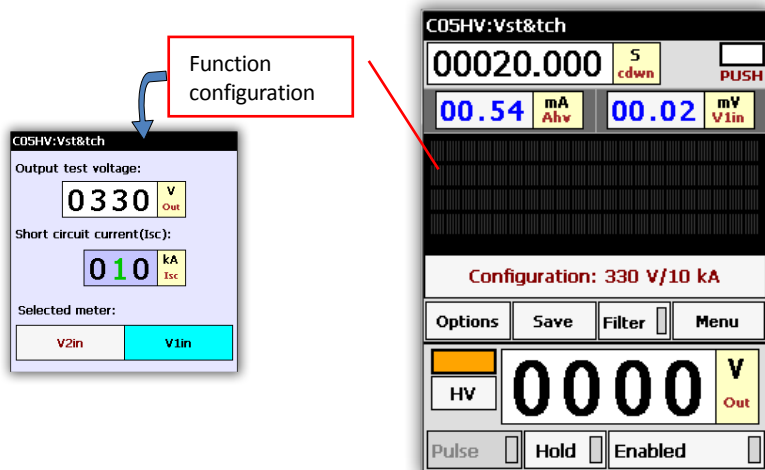

The following parameters can be established when configuring the test:

- **Output test voltage.** This is the voltage level that will be injected in phases 2 and 3 of the test (the different phases during the execution of the function are explained in the following section).

- **Short circuit current.** This is the short circuit current of the mesh to be tested, and it is the reference value on which the step and touch voltages will be calculated. It is expressed in kA and the default value is 0 kA.
- **Selected meter.** This is the meter that is going to be used to take the voltage values measured during the test. The choice of one or the other will thus depend on the voltage levels that are going to be measured. By default it is meter V1 in.

Connections:

The following accessories are required to carry out this test:

- Accessory that, when coupled to the step and touch voltage measurement input of Raptor MS generates a differential input R to the 1K meter. In parallel, it also incorporates a protection to protect the measurement input and the user.
- Drum + 15... 20 m shielded and twisted cable for step and touch voltage measurement.
- Drum + 50 m cable for 1kV/5A injection.
- Two reinforced iron legs.

For the touch voltage test, the measurements are carried out between the floor and all the metal surfaces of the substation and the perimeter enclosure mesh. The procedure below is followed:

1. One 25 kg leg is placed one metre away from the metal surface where the touch voltage is going to be measured.
2. A resistance of 1000 Ω is installed between the metal surface and the test stand.

Raptor MS

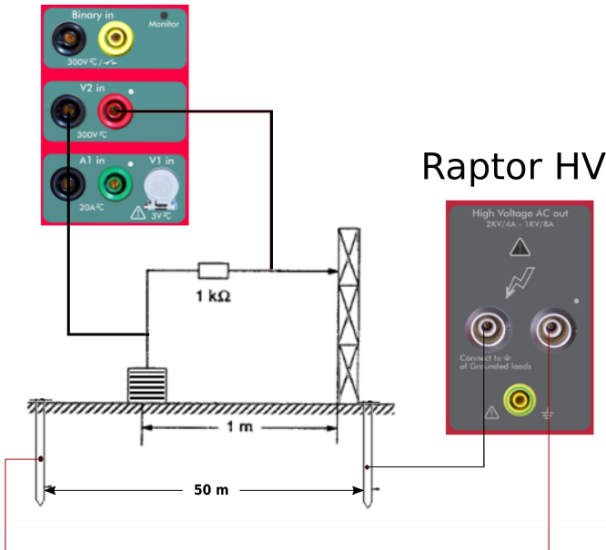

For the step voltage test, the measurements are carried out between the two legs separated by a distance of one metre. Furthermore, a 1000 Ohm resistance is installed between the two stands. The voltage is measured between these, repeating the measurement at different points close to the periphery of the earthen mesh and close to the substation enclosure.

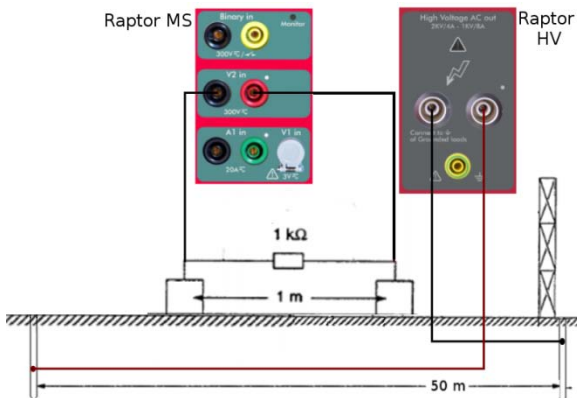

Test:

The execution of the function is made up of three phases, which will automatically be developed without the user's intervention (each phase will consume one third of the countdown):

- *Phase 1.* The Raptor HV will inject 0 Vac and will obtain the Step and Touch voltage generated by external currents to the Raptor. This is defined as "VO".
- *Phase 2.* The Raptor HV will inject the voltage assigned in the configuration, in phase with the line, and will obtain the Step and Touch voltage generated by the latter and by external currents to the Raptor. This is defined as "V+".
- *Phase 3.* The Raptor HV will inject the voltage configured in the function (as in phase 2), in counterphase with the line, and will obtain the Step and Touch voltage generated by the latter and by external currents to the Raptor. This is defined as "V-".

The VO, V+ and V- values are shown on the central panel as they are calculated. Finally, if the 3 phases conclude with satisfaction, the step and touch voltage *Vst&tch* voltage referring to the short circuit current (*Isc*) configured, will be shown, together with this. If the test does not end properly the text "Function error" will appear.

Function process:

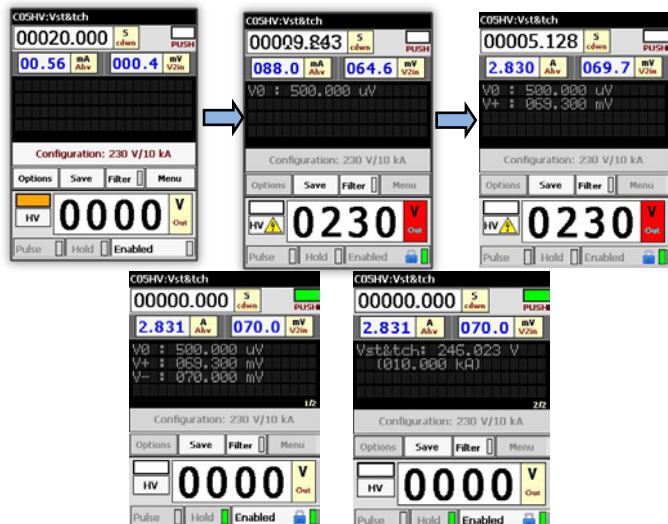

The following expression is used to calculate the step and touch voltage.

$$V_{st\&tch} = \sqrt{\frac{V_-^2 + V_+^2}{2} - V_0^2}$$

To obtain the real step and touch voltage values, proportionality must be applied between the current measured in the meter I_{Ahv} and the current configured as I_{sc} , in such a way that:

$$V_{real} = V_{st\&tch} \frac{I_{sc}}{I_{Ahv}}$$

If a value of $I_{sc}=0$ has been assigned in the test configuration:

$$V_{real} = V_{st\&tch}$$

NEED MORE CURRENT, VOLTAGE or POWER

One of the most frequent questions is the current limit that users can obtain from the system over a certain burden. This is especially frequent when the user wishes to exceed the nominal current of the test equipment or he is trying to use long cables to carry high current.

As you know, to obtain high current, the maximum output voltage possible from the injector equipment is required as well as the minimum load impedance possible.

Maximum output voltage of the system

The power supply

One of the most common errors is not to pay the necessary attention to the power supply of the system.

Bear in mind the maximum admissible consumption for each unit:

Raptor MS: 19 A in permanent, 38 A for 3 minutes and 74 A for 3 seconds.

Raptor SL: 26 A in permanent, 52 A for 3 minutes and 104 A for 3 seconds.

The feed cables supplied with each unit are adequately dimensioned for these consumptions. The part that you have to pay attention to is the cable that takes the power supply to the system. You must add up all the consumptions foreseen for each unit and dimension it so that 4.5 A/mm² are not exceeded in permanent regime. Although with this current density calculated for the permanent, it is correct to use the system in 3 min. and 3 s. regimes, if you wish to optimise the output voltage in the other regimes (3 min, 3 s) set the cable to the same density.

Recommended cross-sections for each conductor (in mm²) for the feed cable of the entire system:

System	Permanent	3 minutes	3 seconds
C-05	4	10	16
C-15	10	16	35
C-25	16	35	50
C-35	25	50	70

You must bear in mind that the Raptor gives its maximum power with a 240 Vac supply, measured at the start of the feed cable supplied. Insofar as this voltage is less or if it drops during the test, the maximum current or maximum voltage will also drop.

If you supply the system with a Generator and this has regulation, try to set it a little higher (for example at 250) to try to compensate the drop that will occur at the time of

injection. Take care not to exceed the equipment specification at any time (230 + 10%). If you are not sure about the possible reaction of the generator regulation on removing burden, do not follow this recommendation.

Number of turns.

In traditional primary injection equipment, you must adapt to the different output ranges. If you choose one with greater voltage, you will have less current or vice-versa. The same occurs in the Raptor system, but with the number of turns. If you wind 2 turns you will have double the voltage and half the current; if you wind 3, you will have triple the voltage and a third of the current. The difference is that in the Raptor system, the number of output ranges is much greater, enabling you to adapt more to the voltage/current need.

Thus, the best adaptation will always be achieved when you can wind the maximum number of turns, for the required current and time.

Number of Raptor SL units

The Raptor SL slave units do not determine the maximum current that the system can handle, but they do provide voltage for the pass-through winding. Each unit will increase the available power by 5 kVA in permanent regime, which is the equivalent to approximately between 0.6 and 1.3V per turn (depending on the regime). When you wish to work with high currents/power, the best solution is to add these units to the system.

Minimum load impedance

This is the other factor that attention must be paid to when maximising the available power/current. Normally, in tests with high currents, the limitation is determined by the connections used to join the injection system to the burden to be tested, as the latter, apart from being fixed, is negligible.

Distance to burden.

The circuit impedance (both the resistive part and the inductive part) is directly proportional to the distance that exists between the burden and the injection system. Try to shorten this distance as much as possible. Sometimes it is more advisable to have several shorter cables than one long one. In this way you will not be forced to use longer ones than necessary. You can always place them in series for greater distances or place them in parallel to increase the cross-section.

Due to the modular construction of the Raptor system and to the reduced weight of each unit, sometimes it is more practical to raise the units close to the burden, for example, on a forklift truck, than coping with the weight and cross-section of the cables.

The cross-section of the secondary conductor.

In order to minimise the resistance of the injection circuit, it is recommended to use the largest secondary cross-section possible, when you are optimising the power / current. The hole diameter for the pass-through winding of the Raptor system is optimised for the current density to be low.

On the other hand, you must know that copper, like almost all materials, increases its resistivity with temperature, being able to increase the resistance of the circuit up to 5% with the subsequent drop in available power. It is therefore advisable, when this factor is decisive to obtain the current, for you to leave the cables to cool down.

The minimum cross-section recommended for the secondary winding is $4\text{mm}^2 / \text{A}$ for the permanent regime, $8\text{mm}^2/\text{A}$ for 3 minute and $16\text{mm}^2/\text{A}$ for 3s.

Parasitic inductance.

It is common to find that operators worry considerably about the resistance of the circuit but they forget about the inductance, which, as you know, is vectorially added to obtain the impedance. Well, this reactance, after dealing with the issue of the cross-section, is what has the greatest influence on not being able to reach the necessary current values.

The only action you can carry out to improve (decrease) the inductance is to care for geometry of the path. The area covered by the turn left by the outgoing conductor with the return conductor must be reduced to a minimum, reducing to a minimum the area of the turns, if any, wound around the raptor system to configure the secondary.

Join the cables of both sides with insulating tape or with clamps, and keep them joined together, to reduce the space between them as much as possible, along their entire length. Interlace the outgoing cables with the return ones is one of the best tactics.

To reduce to a minimum the parasitic inductance generated when configuring the pass-through winding with the Raptor system, it is recommendable to acquire high current ultra-flexible cables, supplied by SMC, as optional elements, measuring 3, 6 and 9 m long.



All these considerations only affect the Raptor MS and SL units. The generation of voltage by Raptor HV only depends on the range and on the load selected. The times for each operating regime can be consulted in the chapter on specifications, at the end of the document.

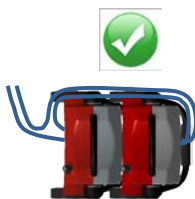
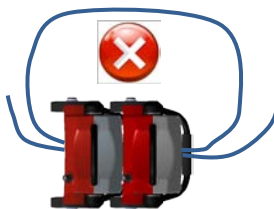
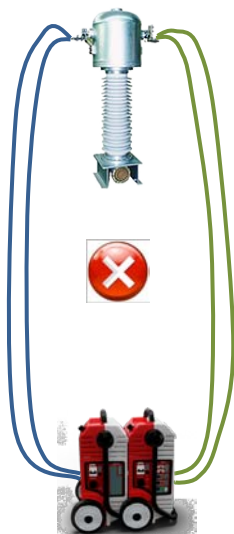

CONFIGURATION AND MAINTENANCE

Configuration



Access the menu:

Change language



Change date and time of the system

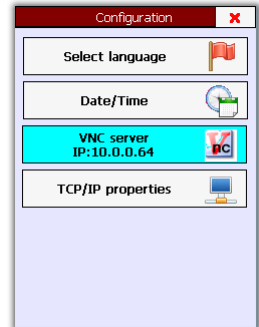

Adjust Internet connection properties (TCP/IP)

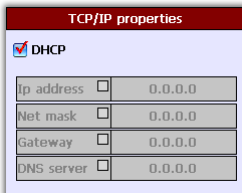

At times, such as to update your system or to control it from the PC (useful for remote support or courses), you must connect the Raptor HH console to the Internet. Certain parameters must be adjusted for the communication to be correct.

DHCP mode is active by default, meaning that the IP address of the Ethernet adaptor will be configured automatically, when you switch on the equipment after connecting the mains cable. This system will only work correctly when there is a DHCP Server in your network. Consult with your network administrator to see if this exists. For this reason, the manual configuration panel is disabled, as shown on the previous image.

If there is no DHCP Server in your network or you are going to connect directly to a PC, you must set the parameters of the console network adaptor by hand.

To manually establish the addresses and mask, deactivate the DHCP option.

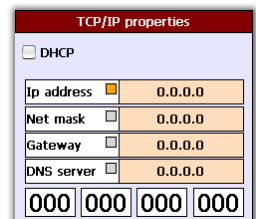

If you are going to connect the console to a network without DHCP Server, you must ask the administrator to give you these four parameters. You can copy the last three (Net mask, Gateway and DNS Server) from any computer that you have connected to the network. The IP address no. This must be exclusive in the network.

If you want to connect the console directly to a PC (only for VNC use), proceed as follows:

- Open the properties of the PC network card and take note of the four parameters shown on the figure.
- Copy the last three (Net mask, Gateway and DNS Server) into your device.
- In the IP address, put the same first three groups as those of the PC and in the fourth group, put any number except for that of the PC.
- Save the configuration.



If the Internet parameters are not configured on your PC, you must enter them by hand IP:192.168.1.1 / Net Mask:255.255.255.0 Gateway:0.0.0.0 DNS Server:0.0.0.0



In some cases, the direct connection to the PC does not work, even after having correctly configured the parameters. In this case, try with a crossed Ethernet cable or inserting a switch.

VNC Server



This permits showing/controlling the Raptor HH device from the screen of a local or remote computer. This is useful, if, at any time, you want your equipment to be directly controlled from SMC to make any kind of adjustment, to clear up doubts or receive training.



Before trying to use this function, you must correctly configure the Internet connection properties.

To establish the connection, a VNC client application is started up on the computer from where you are going to make the connection. We will use the *TightVNC viewer* client, a free application available from page:

www.tightvnc.com/download/1.3.10/tightvnc-1.3.10_x86_viewer.zip

After starting up the VNC client, you must select the *listen* mode, pressing the “Listening mode” button, as the connection is started by the Raptor HH VNC server. You do not have to indicate anything in the “VNC server” field.

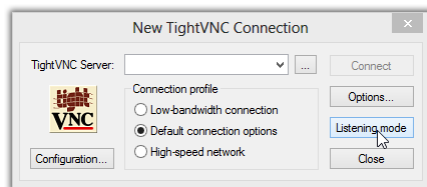

You must now start up the Raptor HH VNC server. Press the **VNC Server** button on the configuration menu to access the following screen:

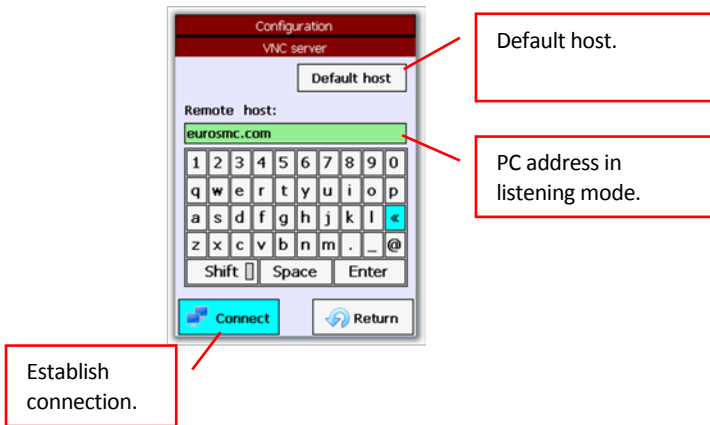

If you want to contact SMC for remote support, write the remote address: "eurossmc.es" or press **Default host**. If, on the contrary, you wish to contact a PC on your local network or your own PC, you must enter its IP address.



If you are going to connect with SMC, you must wait until you are told you can press the **Connect button.**

If you have decided to connect to a PC of your network, a window will appear on this PC like the one shown below after pressing **Connect**.

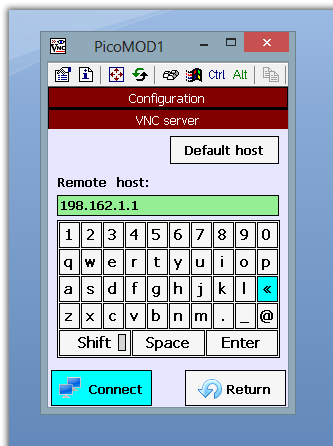

You will now see an exact copy of your Raptor HH screen. You may even press on the keys and execute certain controls.

Safety adjustment in Raptor HVunit .

If you have a Raptor CV-X5 system (with HV case), there are some important safety options that apply when power is being generated.

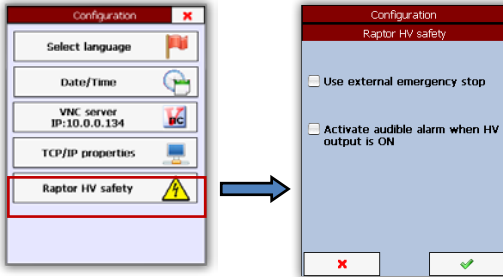

- *Use external emergency stop.* It is activated by default. If it is active, the test can be stopped or the power generated by means of the optional pushbutton of the Raptor HV equipment. If pressed, the power generation ends, which is reflected by means of an **Ovl** alarm.



If an *overload* alarm is activated when starting up the system, without even having selected the HV output, this may be because this option, **Use external emergency stop**, is activated. Deactivate it.

- *Activate audible alarm when HV output is ON.* This option is activated by default.

Keep the system up-to-date



Access the maintenance menu

From this menu you can access different options that will help you keep your system up-to-date. Among the possible options:

- Update control program of the Raptor HH unit.
- Update firmware of the Raptor MS unit.
- Consult the Firmware versions of the Raptor SL units.
- Consult serial numbers of the units that make up the system.
- Adjust the Hardware meters (this requires password).



Update control program of the Raptor HH/M.



Every now and again, SMC publishes updates on its Internet servers of the control program of the Raptor HH and Raptor MS units, which corrects problems detected, introduces improvements or adds functions. You can access these updates when you wish. You can see which version of the console software you have on the actual button.

The only way to exit this menu is by pressing **Restart**.

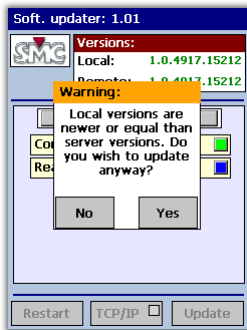

If you have not already done so, you must adjust the TCP/IP parameters as indicated in the “Configure the Internet connection parameters” section with the **TCP/IP** button.

When you press the **Update** button, the download and updating process will start. If the version that exists in the SMC server coincides with the one you have in your console, a window will appear indicating this. Otherwise, it will continue with the process. Press **Restart** when it finishes.

Whenever you update the console, an update of the Master unit will be downloaded at the same time. The next time you have a Raptor HH unit connected to a Raptor MS unit, and after restarting, it will automatically proceed to verify that both versions are the same. If these do not coincide, the program will take you to the “Update firmware of the Raptor MS” screen.



Update firmware of the Raptor MS/Raptor HV units.



You must always update the Raptor MS unit and Raptor HV (in case you have it) after you have updated the Raptor HH unit. Although the procedure is the same in both cases, there is a different option for each one. You do not have to do it immediately, but the system will force you to do so before start working with this unit.

A window will appear like the one on the right. Press **Re-save**.

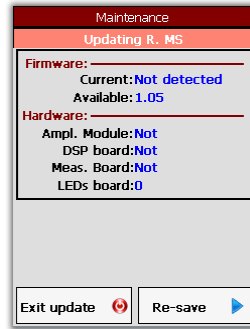

Consult the Firmware versions of the Raptor SL unit.



With this option, you can know which version of the firmware exists in the Raptor SL units.

Consult serial numbers of the units that make up the system.



This enables you to see the serial numbers of all the units that make up the system.

Adjust the Hardware meters



This permits modifying the setting of both the internal and the Hardware meters. This option requires a password to be provided by SMC.



Caution – This maintenance option must only be used by people with advanced knowledge of the Raptor. Any modification of the parameters of these settings will affect the performance of the equipment.

The screen is shown below:

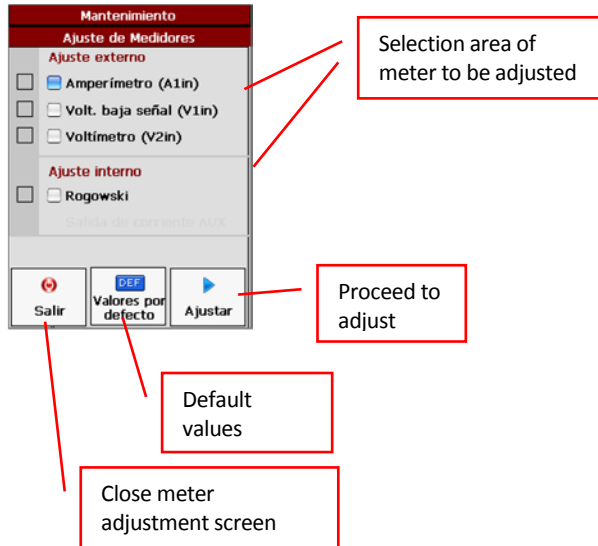

Exit. This closes the meter adjustment window and returns to the maintenance window.

Default values. This assigns the default values to the selected meter, in all the ranges.

Adjustment. This starts the adjustment process of the selected meter. Once you start to adjust the meter, you must finish the process, at least in one range, if you have several, because if you abort, it will be saved with incorrect values. You are only allowed to exit the adjustment process when you finish a complete range or, if the meter only has one range, when the entire process has been completed. The adjustment process is guided through an assistant and only requires following the steps indicated.

Adjust the Raptor HV Hardware meters



This permits modifying the adjustment of both the internal and Hardware meters of the Raptor HV unit. This option requires SMC to provide you with a password.



Caution – This maintenance option must only be used by people with advanced knowledge of the Raptor. Any modification of the parameters of these adjustments will affect the operation of the equipment.

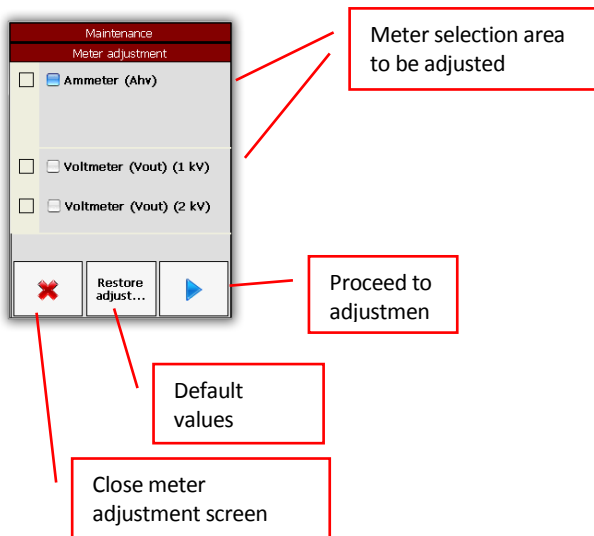

Exit. Close the meter adjustment window and return to the maintenance window.

Restore adjust. This restores the system adjustments. You can choose between the default values or factory values. They will be applied to the selected meter, in all the ranges.

Adjust. This starts the adjustment process of the selected meter. Once the adjustment of the meter has started, it must be completed, at least in one range, if it has several, because if aborted, incorrect values will be recorded. It is only possible to exit the adjustment process when a complete range has finished or, if the meter only has one range, when the entire process has finished. There is an assistant to guide you through the adjustment process and you only have to follow the steps indicated.

Factory settings



These permits modify internal hardware and software settings. This option permits access with two levels of restriction.

This sensitive maintenance area is protected from accidental changes by a password that must be provided by SMC.

PROBLEMS THAT MIGHT ARISE

SPECIFICATIONS
Raptor MS

Raptor MS master unit	
(values @240 Vac, 50 Hz, 1 sec. turn 960 mm ² , measured 25 cm on each side)	
HIGH CURRENT OUTPUT	
Output Current	Output Voltage
No Load V (0%Imax)	0-1,20 Vac - Continuous
3,8 kAac (25%Imax)	0-0,81 Vac - Continuous
7,5 kAac (50%Imax)	0-0,42 Vac - 3 min
9,5 kAac (63%Imax)	0-0,22 Vac - 3 s
No Load Resolution	25 uVac
Output Frequency	20-400 Hz (Power reduction applied at 50 < f > 60 Hz)
LOW CURRENT OUTPUT	
(Not simultaneous with high current output)	
Output Current	0-35 Aac (0 – 9 Aac continuous)
Output Voltage	0-200 Vac
Output Power	4.9 kVA / 1.7 kVA continuous
Output Frequency	20-400 Hz (Power reduction applied at 50 < f > 60 Hz)
Isolated output	yes
Protection	fuse
MEASUREMENTS	
Secondary Current (for high current output)	
Ranges	0-1 / 0-15 KAac
Resolution	1 Aac, 10 Aac
Accuracy	±0,2% of the value ±0,2% of the range
Phase angle	±0,25°
Ammeter/Low Level Voltmeter	
Amm. Ranges	0-0,2 / 0-2/0-20 Aac
Amm. Resolution	0,1 mAac, 1 mAac, 10 mAac
Amm. Impedance	<10 mΩ
Volt. Ranges	0-30 mVac, 0- 0,3 Vac, 0- 3 Vac
Volt. Resolution	0,015 mVac, 0,15 mVac, 1,5 mVac
Volt. Impedance	>3000 KΩ
Frequency range	20-400 Hz
Accuracy	±0,1% of the value ±0,1% of the range
Phase angle	±0,25°
Isolated input	yes
Voltmeter	

Ranges	0-0,2/0-2/0-20/0-300 Vac
Resolution	0,1 mVac, 1 mVac, 10 mVac, 0,15 Vac
Impedance	>120 KΩ
Frequency range	20-400 Hz
Accuracy	±0,1% of the value ±0,1% of the range
Phase angle	±0,25°
Isolated input	yes
Binary Input	
Type	Dry contact/Voltage
Voltage mode Levels	1,5 V , 15 V
Time resolution	1 ms
Max. Voltage	250 Vac
Isolated input	yes
COMMUNICATIONS	
2 RS-485	Raptor Bus connectors to control unit Raptor HH and/or other units
2 IrDA interfaces	Two channels for master/slaves linking
GENERAL	
Supply	230 ±10%, 50/60 Hz
Max. Supply Current	50 A RMS (240 V, when Raptor System max. power in 3s.)
Weight	35 kg
Protections	Protected by miniature circuit breaker
Sec. hole diameter	85 mm
Transport	Wheels, folding handle, fixed handle

Raptor SL

Raptor SL slave unit (values @240 Vac, 50 Hz, 1 sec.turn 960 mm ² , measured 25 cm on each side)	
HIGH CURRENT OUTPUT	
Output Current	Output Voltage
No Load V (0%I _{max})	0, 0.79 or 1.59 Vac - Continuous
3,8 kAac (25%I _{max})	0, 0.67 or 1.34 Vac - Continuous
7,5 kAac (50%I _{max})	0, 0.55 or 1.11 Vac - 3 min
15 kAac (100%I _{max})	0, 0.30 or 0.61 Vac – 3 s
COMMUNICATIONS	
2 IrDA interfaces	Two channels for master/slaves linking
GENERAL	
Supply Voltage	230 ± 10%, 50/60 Hz
Max. Supply Current	100 A
Weight	35 kg
Protections	Protected by miniature circuit breaker
Sec. hole diameter	85 mm
Transport	Wheels, folding handle, fixed handle

Raptor HH

Raptor HH Hand Held Console	
CONTROL	
Display	Transflective high definition color TFT with resistive Touch Panel, 54x71 mm (5,7")
Wheel	Rotary Encoder (Wheel and click)
LEDs	Alarm, Connectivity, Power
COMMUNICATIONS	
RS-485	Raptor BUS Communication with Raptor MS
USB	Connection to PC (RaptorSync)
RJ-45	Ethernet for software updates
	Mini-PC powered by Windows CE
GENERAL	
Power Supply	Self-powered from Raptor MS, or with external power adapter 5 Vdc
Weight	0,4 Kg
Dimensions	110 x 185 x 35 mm
Case	High quality injection-moulded ABS, strong and ergonomic design, edge surfaces protected with TPE non-slip material
Compliance	The instrument is intended for use in high-voltage substations and industrial environments. All EuroSMC products have conformity to CE-marking directives, complies with IEC and international standards, and are designed and manufactured in accordance with the requirements of the ISO-9001 Quality Standard
Transport Bag	Nylon soft bag
Connection cable	5 m cable, 8 mm



Raptor HV

Raptor HV High power Unit (@240Vac, 50Hz)		
AC output voltage	AC max. current output	Regime
0..2kV	1A	Permanent
0..2kV	2A	3 min
0..2kV	2.5A	2 min
0..1kV	2A	Permanent
0..1kV	4A	3 min
0..1kV	5A	2 min
No-load resolution	1 Vac	
Output frequency	20-400Hz	System applies power reduction with upper frequencies than 60 Hz or lower than 50 Hz.

Meters @(10..100)% del rango / 50-60Hz	
Secondary current (Internal)	
Ranges	0,08 / 0,8 / 8Aac
Resolution	0.04 / 0,4 / 4mAac
Frequency range	20 – 400 Hz
Level accuracy	0.1% RD + 0.1% FS
Phase accuracy	+/-0,25°
Secondary voltmeter (Internal)	
Range	1000 / 2000 Vac
Resolution	1Vac

Frequency range	20 – 400 Hz
Level accuracy	0,1% RD + 0,1% FS
Phase accuracy	+/-0,25°

PROTECTIONS	
Over-temperature	
Supply fault	
Communication fault	

COMUNICATIONS	
RS-485	Channel in included in expansion connection

EXPANSION CONNECTOR		
Max. cord leght : 1 m		
Amplifier power enter	160Vac @ 16 A permanent – 32 A 3'	
RS-485 channel		
Bus supply	+5V	
Phase reference	Yes	
General supply	230Vac@1A	

GENERAL		
Supply	From Raptor MS expansion connector	
Weight	28 kg	
Transport	Wheels and handler	
Ventilation	In/Out slots + forced ventilation	

Ordering Information

ORDERING INFORMATION	
SYSTEM CONFIGURATION	
Raptor C05	1 x Raptor HH + 1 x Raptor MS
Raptor C15	1 x Raptor HH + 1 x Raptor MS + 1 x Raptor SL
Raptor C25	1 x Raptor HH + 1 x Raptor MS + 2 x Raptor SL
Raptor C35	1 x Raptor HH + 1 x Raptor MS + 3 x Raptor SL
Raptor CV-05	1 x Raptor-HH + 1 x Raptor-HV + 1 x Raptor-MS
ACCESSORIES INCLUDED	
Raptor HH	Hand held console with software
	Stylus
	Nylon Bag
	System cable
	USB cable
	Ethernet cable
	Power adapter
	User's Manual
Raptor MS	Raptor master unit
	Power supply cord
	Low signal voltmeter cable
	Connection cables set
	Spare fuses
	Set of alligator type clips
	Calibration certificate
	Nylon protective bag
Raptor SL	Raptor slave unit
	Power supply cord
	Spare fuses
	Nylon protective bag
Raptor HV	Raptor HV unit
	Connection cable with Master unit
	HV Test Leads, 2 x 6 m

	Set of 2 injection clamps
	Nylon protective bag
OPTIONAL ACCESSORIES	
CBL3M-RAP	120 mm ² cross section and 3 meters (9 ft) long
CBL6M-RAP	120 mm ² cross section and 6 meters (18 ft) long
CBL9M-RAP	120 mm ² cross section and 9 meters (27 ft) long
RAP- ACC1	Up to 4 CBL cables can be connected
RAP- ACC2	Up to 6 CBL cables can be connected
RAP- HCC	Pair of High Current Clamps
CBL-HH4M-RAP	4-meter (12 ft) extension for the RS-485 communications cable, if you need to stay at a distance greater than 5 meter from the Raptor Master.
RAP-PT	Raptor Polarity Tester
RAP-LAMP	External warning lamp for Raptor HV, rotary type.
RAP-STOP	Emergency Stop for Raptor HV, mushroom type, lockable, with magnetic hold.
RAP-SET-S&T	Raptor HV Step & Touch accessory kit, composed by the 25-kg iron electrodes, input switch, and 50m/20 m injection/ measurement leads.
TC-03	Sturdy ABS transport case with wheels and extensible handle

Appendices

Raptor PT accessory

General description

The Raptor PT is a lightweight handheld accessory that allows to easily check for correct or inverted polarity at distant or difficult to reach connections while the Raptor injects a polarized waveform.

The Raptor PT provides two thin probes (one on the instrument's body and the other at the end of a short cord) that the user applies onto any two points in a circuit (e.g. the connections of a transformer or a metering device) whose polarity must be checked. Three LEDs will instantaneously indicate correct, inverted or undetermined polarity, whereas a fourth LED will warn the user to replace the internal batteries.



Applications

The Raptor PT's greatest benefit is easy and safe polarity checking in transformers of any type (power, measurement or protection).

Usage

For the *Raptor PT* accessory to work properly, a Raptor system must be previously set to inject current in *polarized mode* into the circuit.



Caution – Before connecting the injection cables which come from the Raptor, make sure you have disconnected any supply to the circuit to test. If you don't do it, you can suffer serious damages or even the death. Additionally, the Raptor System and the Raptor PT accessory can be damaged permanently.

While the polarized current is flowing in the circuit, apply the probes to both sides of the connection you need to check, press the *Test* button and wait for a results LED to become stable for more than two seconds.

The Raptor PT features three LED indicators and one TEST button:

- **TEST button:** Turns the instrument ON and carries out the polarity test simultaneously. Keep pressed for two or more seconds to ensure a stable result.
- **Green (correct polarity) LED:** The detected signal is found to be in phase with the Raptor system's output.
- **Red (wrong polarity) LED:** The detected signal is found to be in counter-phase with the Raptor system's output.

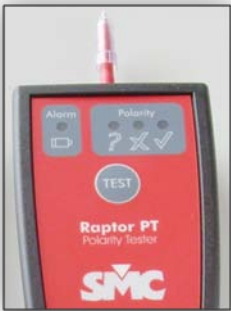

- **Yellow (undetermined) LED:** The detected signal's polarity cannot be determined. Possible causes are:
 - El Sistema Raptor no está inyectando, o está mal conectado.
 - The test current is not polarized. Use a Raptor system with the *Polarity test* template activated to supply a valid test current for the Raptor PT.
 - Raptor PT accessory improperly connected.
 - The injected current is too small. Increase the current level.

- **Orange (Low battery):** The internal AAA batteries are exhausted and must be replaced as soon as possible. Although the Raptor PT will continue working for a while, test results may become unreliable.

Polarity conventions

- Positive or 'phase': grey side of the Raptor's induction tunnel
- Negative or 'neutral': red side of the Raptor's induction tunnel

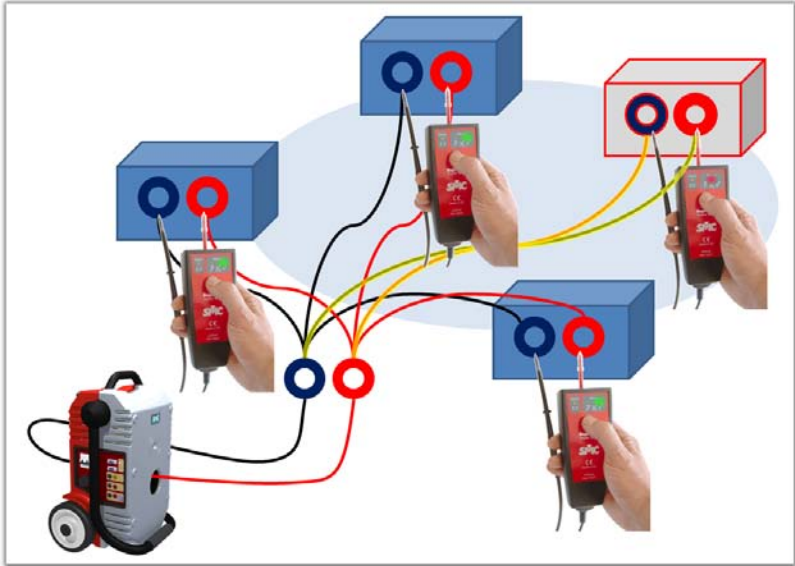

Setting up the Raptor PT accessory

Select *Polarity test* from the *Templates* menu.

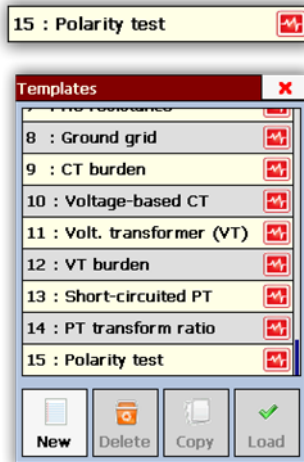

Technical specifications

Technical specifications	
Sensitivity range	5mVac – 300 Vac
Results indicators	Polarity OK(green), wrong polarity (red), undetermined polarity (yellow), low battery (orange)
Test button	Instrument power-on and polarity checking in less than 2 seconds
Power supply	Two AAA size 1.5 V batteries
Power consumption	5 mA (when "TEST" is pressed)
Average battery life	1 year
Weight	250 g
Size	140 x 62,70 x 30,5mm
Case's protection	IP-64
Positive probe length	40 mm
Negative probe length	102 mm

Raptor HV (accessories)

Safety accessories:

Emergency pushbutton.

This accessory permits stopping the power output if an emergency arises. It is a knob type pushbutton, with the following characteristics:

- Knob type pushbutton, with interlocking (the knob must be pulled to recover the position). It has a magnet on the bottom so that it can easily be placed on a magnetic surface.
- 5 m long black flexible hose.



If an overload alarm is activated when starting up the system, without even having selected the HV output, this may be because the option, *Use external emergency stop*, is activated. (See *Safety Adjustment in Raptor H unit*). Deactivate it.

Emergency light.

Power output signal light, with the following characteristics:

- Rotating light beacon.
- Black flexible tube,



Accessories for Step and Touch voltaje measurement test:

The following elements have been manufactured in agreement with the regulation described in the Supplementary Technical Instruction ITC-RAT 13.

External shielded Cable for measurements.

Prepared to be connected to external meter $V2_{in}$ of Raptor MS unit.

- SHIELDED CABLE, 20 m long, 5.89 mm outer diameter;
- Internal precision resistancea (to simulate human body) de precisión, 4W 0.1% 1K Ω .
- Protección fuse, 6,3 x 32mm, 250 mA -1 kV.
- Protección diode, 5W.
- Cable-holder reel

External Cable for injection.

Prepared to support the 1kV/8A of the Raptor HV Unit.

Connected to the power output cable (without clamps) supplied as standard with the equipment.

- Flexible cable, section 1.5 mm², 50 m.
- Cable-holder reel.



Electrodes.

Created in an iron block, with subsequent treatment, with the following characteristics:

- Block (cylinder) with 160 mm x 170 mm base, weighing 25kg.
- Handle for 25 kg weights.
- 4mm multi-contact socket connection terminal.



$V2_{in}$ to $V1_{in}$ switch.

This adaptor permits connecting the external optional cable for measurements to the external meter $V1_{in}$ of Raptor MS unit.

IMPORTANT

