

AVerMedia

Touchboards

205 Westwood Ave, Long Branch, NJ 07740
Phone: 866-94 BOARDS (26273) / (732)-222-1511
Fax: (732)-222-7088 | E-mail: sales@touchboards.com

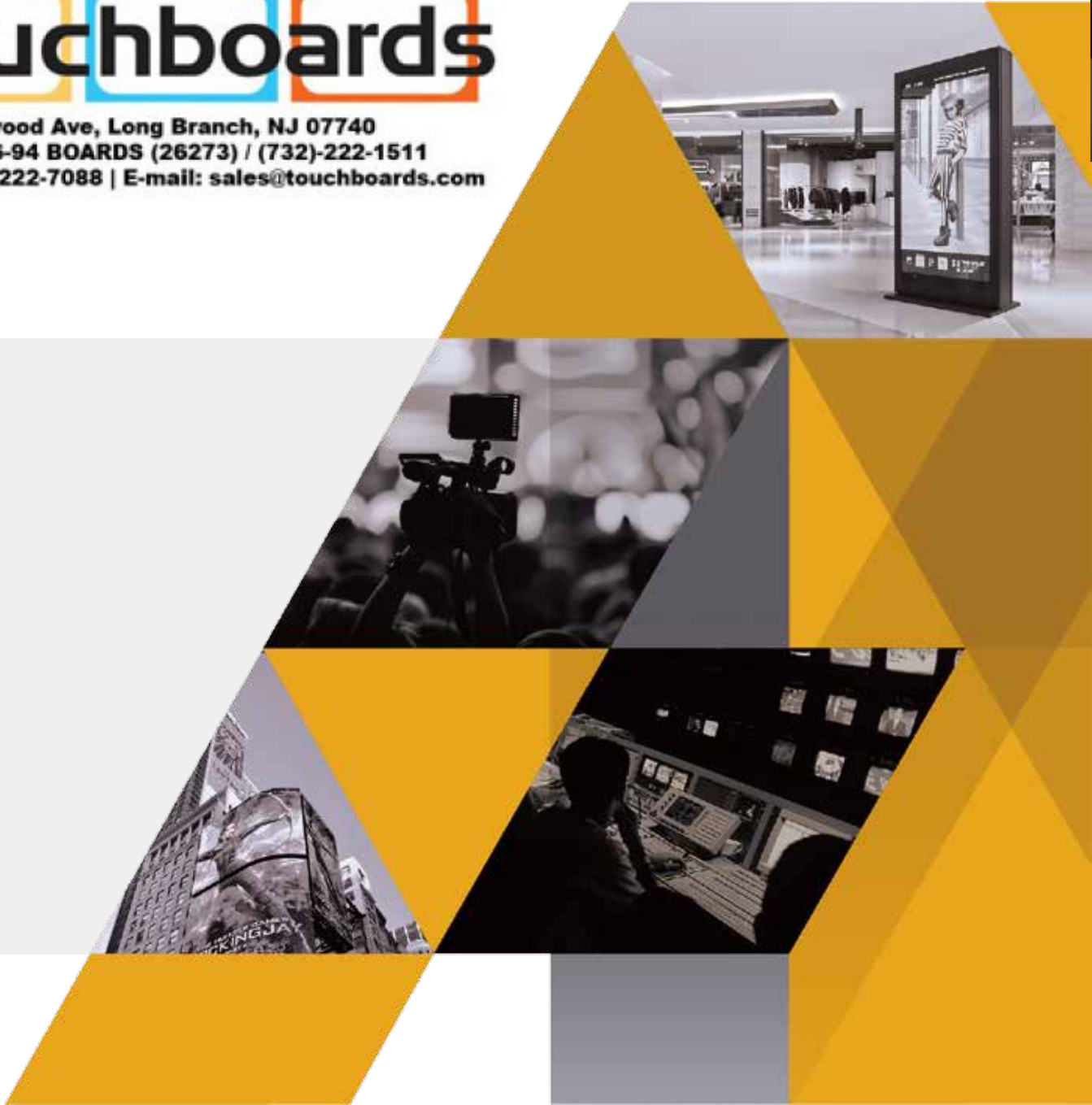

Encode and Stream Solutions

AVerCaster Encoder Series

The AVerCaster encoder is a video capturing, encoding, and streaming solution for the OTT and IPTV industries. It not only broadcasts live TV programs and HD video to a massive audience over LAN and WLAN, but also provides bit rate configurations, resolution configurations, and various encoding options to optimize viewing quality for different commercial applications. By supporting FLASH, Apple HLS, MPEG-DASH and 3GPP, the AVerCaster encoder series allows professional broadcasters to reach large audiences over computers and most internet enabled mobile devices, such as tablets and smartphones.

4K/HEVC Encoder

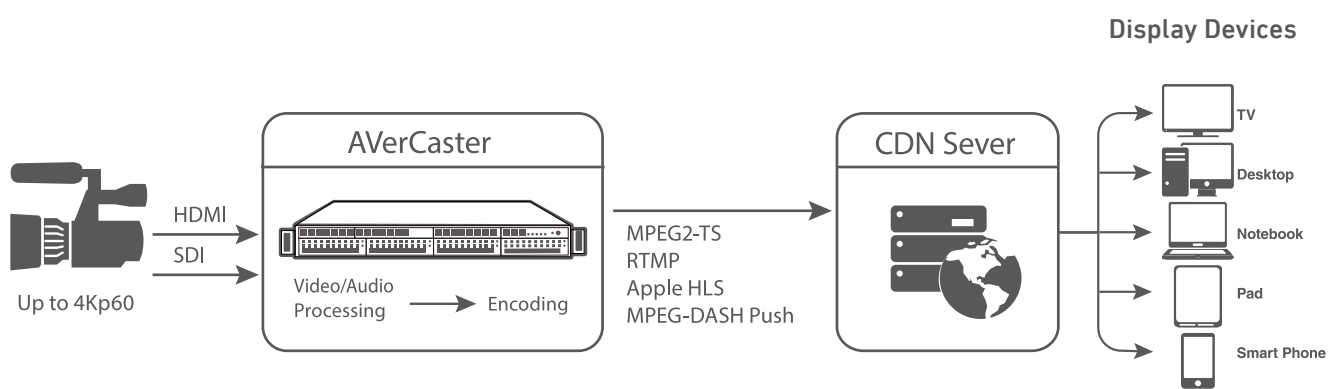

TV Gateway

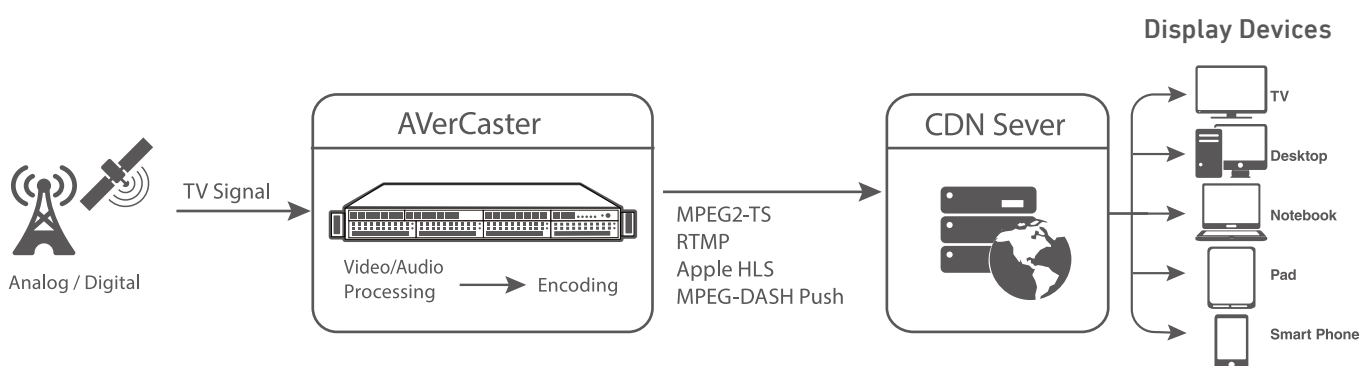

Benefits

- Intuitive interface allows for short learning curve and effortless operation.
- Customizable setup makes a more flexible and easy management, providing a quick but professional setup.
- Highly reliable and flexible platforms, capable of multi-screen stream outputs from a single input source.
- HEVC encoding standard reduces the video content size and allows for a more effective use of the available bandwidth.

AVerCaster Transcoder & Network Management Series (NMS)

To enable the distribution of multimedia content to a wide range of devices in the most adequate and cost effective way, OTT and IPTV applications require the capabilities to transform video and audio content into matching formats according to client devices. The AVerCaster transcoder series meets stringent industry requirements by offering stability and reliability. It includes bit rate, resolution configuration, post video processing features as well as multiple video encoding standards to fully optimize the efficiency and quality in the content delivery process.

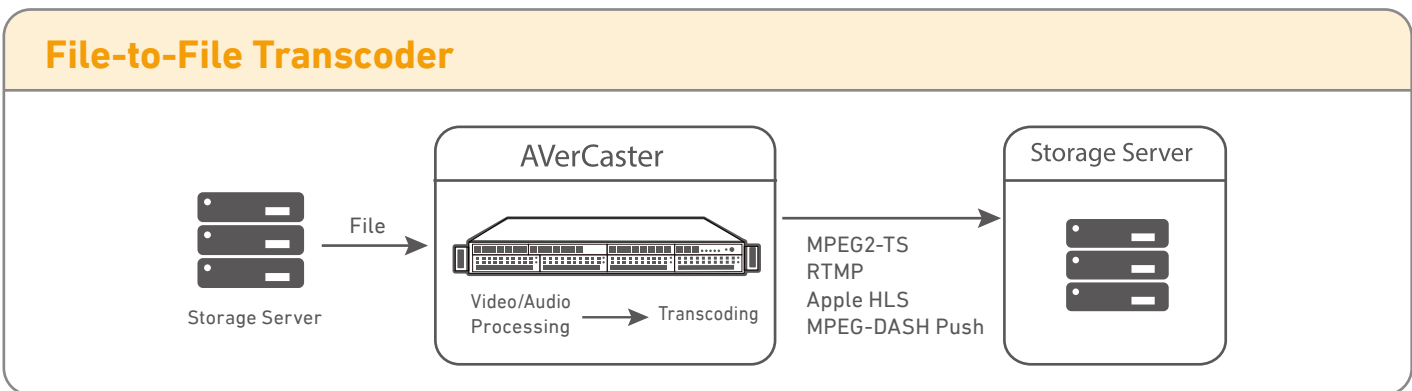
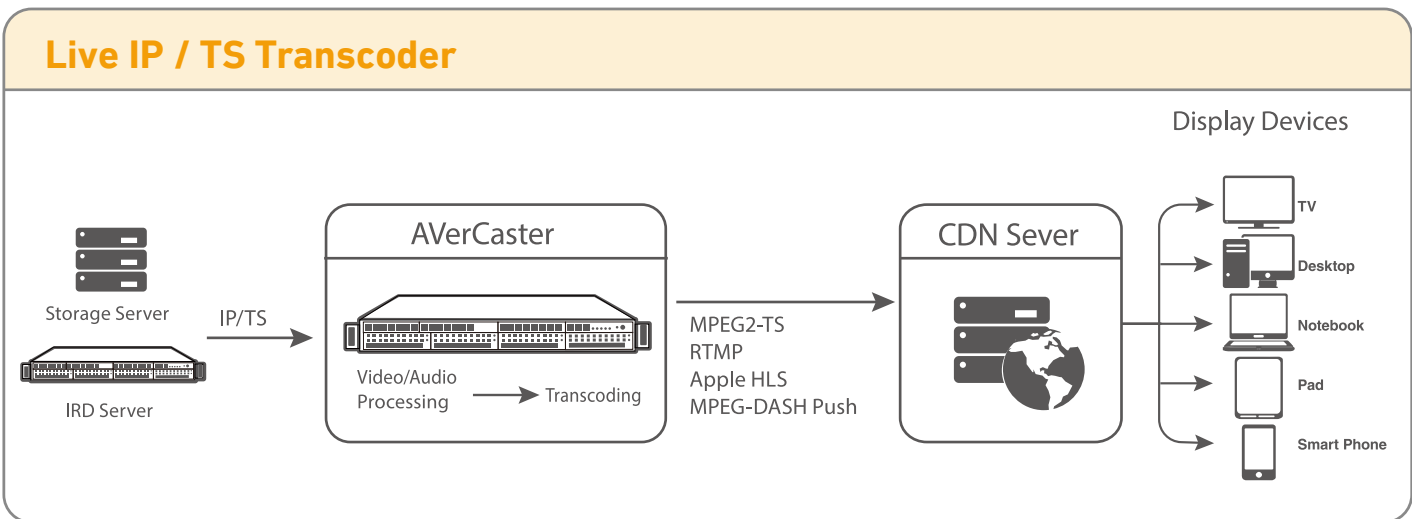

Intuitive WebUI

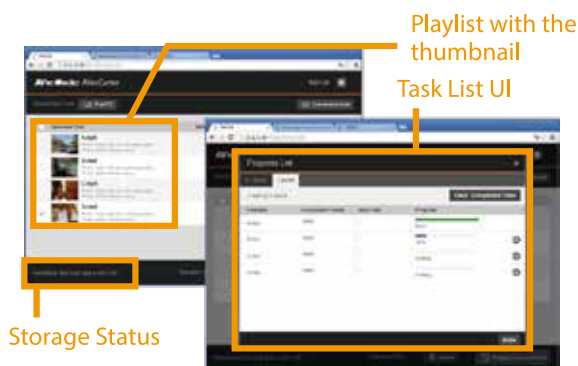

- System status overview
- Comprehensive task management
- On-line/Off-line transcoding

Network Management Server (NMS)

AVerMedia Network Management Server (NMS) monitors and manages all AVerCaster series. Based on a solid platform, the AVerMedia NMS is designed for 24/7 server management services. To ensure reliability and stability AVerMedia NMS features power, streaming, channel and network redundancy capabilities.



Real-time Monitoring WebUI to display all necessary operation information at a glance

AVerCaster Compact Encoder Series

AVerCaster Lite series are compact, easy-to-use and powerful encoders that offers a wide range of encoding profiles. AVerCaster Lite series are able to stream high quality, configurable live HEVC/H.265 and AVC/H.264 video over any network at extremely low bit rates. These standalone streaming devices feature a wide range of input signals from legacy formats to Full HD 1080p, and they are able to encode and stream videos up to a frame rate of 60 FPS. The AVerCaster Lite series are more than capable of fitting into most demanding video delivery workflows.

HEVC Compact Encoders

Compared to today's H.264 encoding solutions, advanced HEVC compression saves up to 50% bandwidth while still allowing users to stream Full HD videos. The AVerCaster Lite HEVC series feature most commonly used inputs in professional video editing including HDMI, 3G-SDI, HD-SDI. It also has an user-intuitive web management software with fully editable H.265 compression settings. AVerCaster Lite HEVC encoders take the most advanced HEVC encoding technology from servers into the field for live event streaming applications that is powerful and can be easily integrated.

H.264 Compact Encoders

Can be easily integrated into most video environments - the AVerCaster Lite series offer various input types including HDMI, component and composite video as well as analog and digital audio. With stream quality that is comparable to broadcast-quality encoders at higher bit rates, AVerCaster Lite series deliver great quality at bit rates lower than 1Mbps. It is perfect for less than optimal internet environments or satellite video transmission systems. AVerCaster Lite series are highly integrable with most popular CDN providers such as Facebook, YouTube, Ustream and others allowing for a wider spread of video content with greater ease.



Benefits

- Intuitive WebUI allows for a quick configuration and management
- Providing HEVC encoding standard solution to help reduce and make more efficient use of available bandwidth
- Streaming stabilizer can meet unstable network condition for smooth video delivery
- High integration with most popular content delivery network (CDNs) such as Facebook, Youtube, Ustream, etc.

VueSign CMS from Live to VoD

AVerMedia's VueSign CMS is a total solution for network delivery of multimedia content with Video on Demand capability to maximize your digital signage investment. Deliver the ability to access video content from any device at any time while maintaining complete control without affecting the viewers experience.

Live-to-VoD can instantaneously add the archived video to the playlist for the audience to select afterwards. The AVerReceiver can easily acquire and display content from the video playlist provided by the VueSign CMS through a network.

Streaming



Display videos and control channels from live broadcasting devices or TV gateway servers

VoD

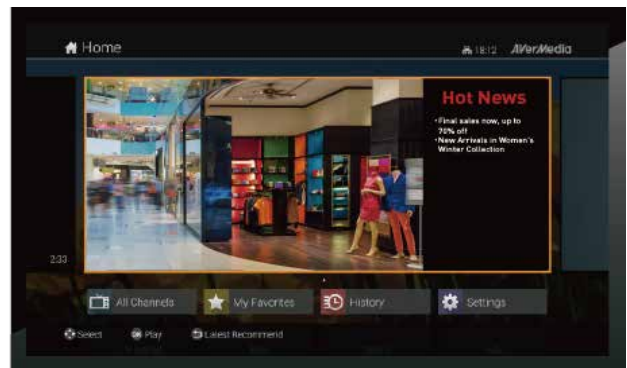

Allow users to select and display the prepared video content with an easy management interface

VueSign CMS WebUI

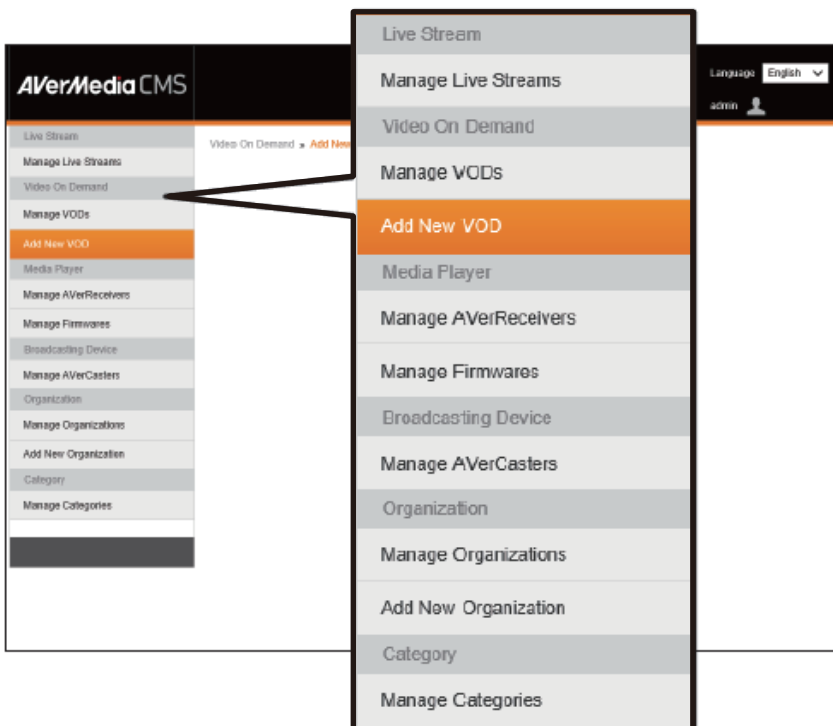

- **Live Streams**
Start or stop live broadcasts and manage the client authority to watch live videos
- **Video-on-Demand**
Upload and manage videos on VueSign CMS and let clients watch them on AVerReceiver
- **Organizations**
Categorize AVerReceiver into groups
- **Categories**
Categorize videos by genres
- **Media Players & Broadcasting Devices**
Designate each AVerReceiver to an organization, and simultaneously administer broadcasts from multiple F239+ or SE510

AVerReceiver SR310 series

Compact, full featured and highly customizable

All multimedia content can be edited on the VueSign CMS and delivered to each receiver by a simple WebUI. Each receiver can display the content organized by the VueSign CMS on both online and offline modes. The VueSign CMS provides all the tools necessary to manage a deploy content across any network of digital displays.

The VueSign CMS features layout editing functions to make the most use of your digital signage platform. From ready-made templates to time stamping, scrolling ticker, RSS feeds to HTML and marquee functions, the VueSign CMS enhances the ability to deliver digital signage content to meet all marketing and promotional needs.

For Retail/Enterprise (SR310)

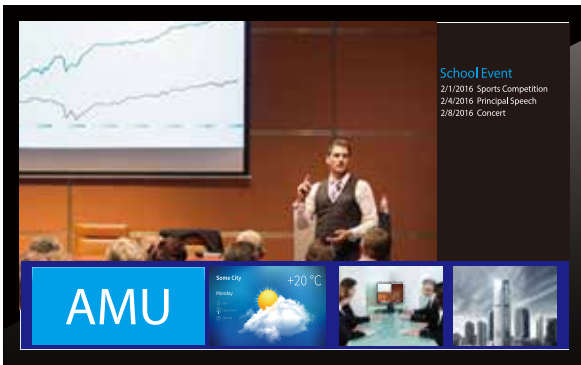

The SR310 is the exclusive player for the VueSign CMS. Placing two different modes in the palm of your hand, the SR310 will allow you to provide live streaming for VoD or digital signage services for a wide range of applications, such as retail stores, education, and enterprise. Naturally, every single SR310 on the network can be monitored and managed with VueSign CMS.

Designed for use with the AVerCaster HD Duet (F239+), the SR310M empowers viewers by letting them choose what they view and how they want to view it. Using its dual streaming decoding feature, the SR310M displays two live streams simultaneously, AVerMedia's proprietary player enables viewers to choose from various preset layouts, providing picture-in-picture or side by side options to choose from. This feature is suitable for lecture streaming and recording, as well as live religious and other public speaking events.

For Education/Religion (SR310M)



For Hospitality (SR310P)



The SR310P was developed to be paired with AVerMedia's Server grade RS7100 encoder series or RS6400 Gateway series. With the entertainment sector in mind, the SR310P is the ideal decoder to provide infotainment services for hospitality providers such as hotels, motels, and hospitals, as well as for in-vehicle applications such as tour buses, airplanes, and even cruise ships. Using its fully customizable features and layout, you will be able to deliver unique brand-quality, and a highly satisfying viewing experience for your guests.



Product Selection

Encoder



Model Name	RS9280	RS9260	RS7190	RS7170
Video Sources Supported	1-channel 4K Quad-link 3G-SDI	1-channel 4K HDMI 2.0	4-channel 3G-SDI	4-channel HDMI
Video Resolution	up to 3840 x 2160p60	up to 3840 x 2160p60	up to 1920 x 1080p60	up to 1920 x 1080p60
Video Codec	HEVC, H.264, MPEG-2, H.263	HEVC, H.264, MPEG-2, H.263	H.264, MPEG-2, H.263	H.264, MPEG-2, H.263
Audio Codec	AAC, MPEG-2, Audio, AMR, MP3	AAC, MPEG-2, Audio, AMR, MP3	AAC, MPEG-2, Audio, AMR, MP3	AAC, MPEG-2, Audio, AMR, MP3

Transcoder



Model Name	RS5130	RS7130
Video Sources Supported	off-line HEVC file transcoding	Live IP/TS transcoding
Video Resolution	up to 3840 x 2160p60	up to 1920 x 1080p30
Video Codec	HEVC, H.264, MPEG-2, H.263	H.264, MPEG-2, H.263
Audio Codec	AAC, MPEG 2 Audio, AMR, MP3	AAC, MPEG 2 Audio, AMR, MP3

NMS



Model Name	RM9150
Server Management	RS7100 series, RS5130, RS6400 series, RS9200 series
Status Monitoring	Stream status, channel status, server status
Operation Info.	Alarm, Log, configuration
Redundancy	Server Failover, Channel Redundancy

TV Gateway



Model Name	RS6450	RS6451	RS6452
Video Sources Supported	8-channel Analog NTSC/PAL (H334)	8-channel ISDB-T (A331)	8-channel DVB-T/T2 (H377)
Video Codec	H.264, MPEG-2, H.263	H.264, MPEG-2, H.263	H.264, MPEG-2, H.263
Audio Codec	AAC, MPEG 2 Audio, AMR, MP3	AAC, MPEG 2 Audio, AMR, MP3	AAC, MPEG 2 Audio, AMR, MP3



Product Selection

Compact Encoder



Model Name	F239+	SE510
Video Sources Supported	Dual-channel Full HD	1-channel Full HD
Video inputs	2 x HDMI 2 x Component	HDMI, CVBS
Video Resolution	up to 1920 x 1080p30	up to 1920 x 1080p30
Video Codec	H.264 Baseline/ Main/High profile	H.264 Baseline/ Main/High profile
Protocol	on TCP/UDP (multicast of unicast)/ RTP (multicast of unicast)/ RTMP publish	Supports RTMP publish/ HLS pull-mode (for preview)

Receiver



Model Name	SR310	
Video Resolution	1920 x 1080 (Landscape) 1080 x 1920 (Portrait)	
Video Format	H.264, MPEG-4	
Audio Format	AAC, MP3	
Ports	USB 2.0	2 x Type A
	DC-in	1 x DC in Jack, 5V 2A
	HDMI	1 x TYPE-A HDMI 1.4b out
	Memory	1 x SD Card Slot

Content Management Server



Model Name	BM110	BM510
Network	2 x RJ45 (Giga Lan)	2 x RJ45 (Giga Lan)
Storage Space	500G	2T
Power	AC 100 ~ 240V DC 9 ~ 36V	100V ~ 240V, 63 ~ 47 Hz, 4 ~ 2 A
Operating Temp.	0 ~ 50°C (32°F ~ 122°F)	0 ~ 50°C (32°F ~ 122°F)
Storage Temp.	20~80°C (68°F ~ 176°F)	0 ~ 60°C (32°F ~ 140°F)

