

ST650 / ST650-S
ST650P / ST650P-S

SmartMount® Universal Tilt Wall Mount for 32" to 56" Flat Panel Displays

The ST650 is indispensable when it comes to display placement flexibility. It features open wall plate architecture that delivers increased electrical access and cable management options. Its exclusive pre-tensioned universal tilt display adapters deliver the ultimate ease in horizontal display adjustment and viewing angle flexibility.



Display size: 32"-56"



Max load: 175lb (79kg)

FEATURES

- Universal mount fits displays with mounting patterns up to 750 x 449mm (29.52" W x 17.67" H)
- Open wall plate architecture allows for total wall access, increasing electrical access and cable management options
- Adjustable up to 15° of forward tilt and -5° backward tilt for optimal viewing angle
- Pre-tensioned universal tilt bracket allows for tilt adjustment without the use of tools
- Easy-grip lever locks the display position into place
- Optional IncreLok™ feature offers fixed tilt angles of -5°, 0°, 5°, 10°, 15°
- Horizontal display adjustment of up to 8" (203mm) (depending on display model) for perfect display placement
- Universal display adapters easily hook onto wall plate for fast installation
- Mounts to wood studs, concrete, cinder block or metal studs (metal stud accessory required)
- Comes with Peerless' Sorted-for-You™ fastener pack with all necessary display attachment hardware
- Integrated security options available
- UL listed

OPEN ARCHITECTURE

Open wall plate architecture for flexible cable management and wall placement

INCRELOK™

Optional tilt lock at 5° increments

DISPLAY ANGLE ADJUSTMENT

Easy-grip lever locks tilt angle into place without the use of tools

IDEAL VIEWING ANGLE

Pre-tensioned tilt mechanism allows for tilt adjustment without the use of tools

Touchboards

205 Westwood Ave, Long Branch, NJ 07740
Phone: 866-94 BOARDS (26273) / (732)-222-1511
Fax: (732)-222-7088 | E-mail: sales@touchboards.com



Adjustable +15/-5° tilt



Model Numbers

WARRANTY: Limited 5-year

ST650(-S)
ST650P(-S)

Universal Tilt Wall Mount for 32" to 56" Flat Panel Displays - security models
Universal Tilt Wall Mount for 32" to 56" Flat Panel Displays - standard models

Product Specifications

	DIMENSIONS (W x H x D)	PRODUCT WEIGHT	LOAD CAPACITY	FINISH	AVAILABLE COLORS
ST650(P)(-S)	33.64" x 18.5" x 2.63"-5.71" (854 x 470 x 67-145mm)	7.94lb (3.6kg)	175lb (79kg)	Scratch resistant fused epoxy	ST650(P): Black ST650(P)-S: Silver

Package Specifications

	PACKAGE SIZE (W x H x D)	PACKAGE SHIP WEIGHT	PACKAGE UPC CODE	PACKAGE CONTENTS	UNITS IN PACKAGE
ST650(P)(-S)	32" x 10.06" x 3.5" (813 x 256 x 89mm)	10.5lb (4.76kg)	ST650: 735029235941 ST650-S: 735029235965 ST650P: 735029235958 ST650P-S: 735029235972	Wall plate, universal display adapters, mounting and display attachment hardware	1

Accessories

ACC415: 4-pack Metal Stud Fastener Kit
ACC309: Video Conference Shelf

All dimensions = inch (mm)

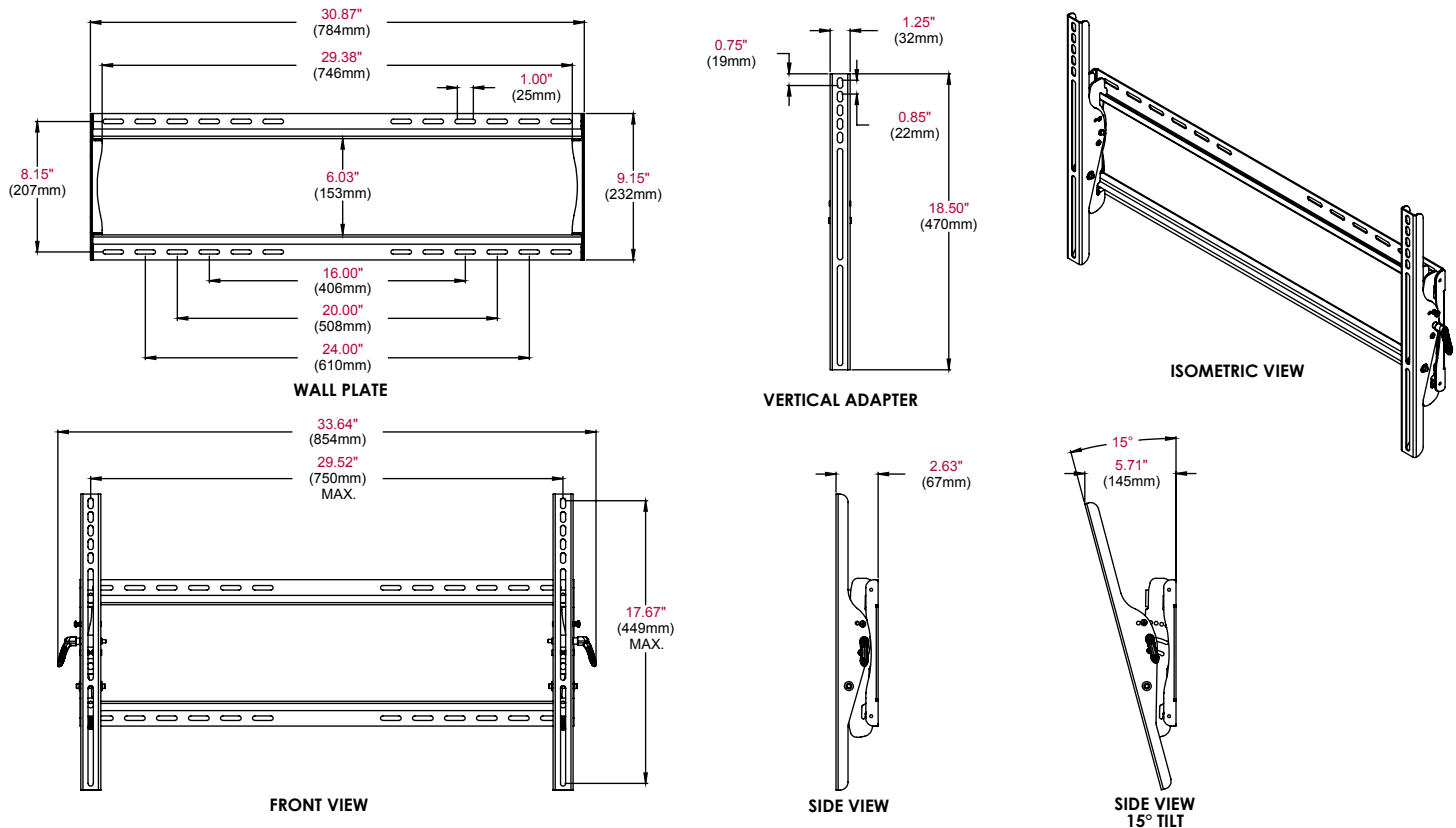

ARCHITECTS SPECIFICATIONS

The Smartmount® Universal Tilt Wall Mount shall be a Peerless-AV model ST650 and shall be located where indicated on the plans. It shall be constructed of heavy gauge cold rolled steel and finished with scratch resistant Black or Silver Fused Epoxy. Assembly and installation shall be done according to instructions provided by the manufacturer.

Peerless Industries, Inc. ■ 2300 White Oak Circle ■ Aurora, IL 60502 ■ (800) 865-2112 ■ (630) 375-5100 ■ Fax: (800) 359-6500 ■ www.peerless-av.com

Visit www.peerless-av.com to see the complete line of AV solutions from Peerless-AV, including flat panel mounts, projector mounts, carts/stands, furniture, cables, screen cleaners and a full assortment of accessories.