

# DIGITAL MICROHMMETER TYPE DO7010



<b>SECTION 1 : INTRODUCTION – SPECIFICATIONS.....</b>	<b>4</b>
MEANING OF THE DIFFERENT SYMBOLS ON THE INSTRUMENT.....	4
1-1 MAIN SPECIFICATIONS:.....	5
1-1-1 Presentation.....	5
1-1-2 Functions and specifications.....	5
1-1-3 Power supply.....	5
1-2 TECHNICAL SPECIFICATIONS:.....	6
1-2-1 Front panel.....	6
1-2-2 Measurement ranges.....	7
1-2-3 Manual or auto triggering mode.....	7
1-2-4 Measurement quality control.....	7
1-2-5 SEQUENCE mode.....	8
1-2-6 RS232 serial interface:.....	8
1-2-7 Power supply.....	9
1-2-8 Unit Dimensions.....	9
1-2-9 Weight.....	9
1-2-10 Remote Control Unit (RCU) specifications (DO7010-REM).....	11
1-2-10-1 Data transfer between PC and the Remote Control Unit (RCU):.....	12
1-2-10-2 Remote Control Unit presentation :.....	12
1-2-11 Data transfer between PC computer and the DO7010.....	13
1-2-12 Wiring synoptic between PC, DO7010 and DO7010-REM.....	14
Lead and probes:.....	15
Picture of some accessories:.....	16
1-3-1 Transportation suitcase DO7010.....	17
1-4 MEASUREMENT METHOD:.....	18
 <b>SECTION 2: BATTERY CHARGER AND ACCESSORIES OPERATION.....</b>	 <b>18</b>
2-1 Battery charger operation:.....	18
2-1-1 Battery charge in the DO7010:.....	18
2-1-2 Battery charge outside of the DO7010:.....	19
2-2 Accessories connection:.....	19
 <b>SECTION 3: DO7010 CONFIGURATION.....</b>	 <b>22</b>
3-1 LCD screen setup: the contrast.....	23
3-2 LCD screen setup: the backlight.....	23
3-3 Auto switch off mode :.....	24
3-4 Keys sound level:.....	24
3-5 Alarm sound level:.....	25
3-6 Measurement trigger mode :.....	25
3-7 Date setup:.....	26
3-8 Time setup:.....	26
3-9 Language selection:.....	27
3-10 Mains frequency selection :.....	25
3-11 Calibration access code:.....	26
3-12 DO7010 AUTOTEST:.....	26

<b>SECTION 4: OPERATING THE DO7010 IN MANUAL MODE.....</b>	<b>28</b>
4-1 MANUAL mode parameters: .....	28
4-1-1 Measurement range selection: .....	29
4-1-2 Measurement current selection: .....	29
4-1-3 Thermocouple error:.....	32
4-1-4 Log mode: .....	33
4-1-5 The limit function:.....	34
4-2 Measurements in MANUAL mode: .....	35
4-3 Measurements in MANUAL mode with the limit function: .....	35
4-4 Measurement in MANUAL mode with the log mode: .....	36
<b>SECTION 5: SEQUENCE MODE.....</b>	<b>35</b>
5-1 Measurement protocol selection: .....	36
5-2 Measurement protocol header display: .....	37
5-3 First measurement of the protocol: .....	37
5-3-1 Example of a PASS measurement:.....	38
5-3-2 Direct access to a test step:.....	38
5-3-3 Example of a FAIL measurement: .....	39
5-3-4 Example of an ABSENT point:.....	39
5-3-4 Example of an OVER measurement: .....	40
5-4 Sequence end: .....	40
<b>SECTION 6 MAINTENANCE and CALIBRATION : .....</b>	<b>43</b>
6.1 <i>PRELIMINARY</i> .....	43
6.2 <i>INSTRUMENT RETURN</i> .....	43
6.3 <i>MAINTENANCE</i> .....	43
6.4 <i>CLEANING</i> .....	43
6.5 <i>CALIBRATION</i> .....	43

## SECTION 1: INTRODUCTION - SPECIFICATIONS



**Warning: This unit must be used by qualified people. Every precaution for the use of units connected to the mains must be taken during its use. In particular, this unit must be connected to earth.**

The specifications of this manual, the correct operation of the unit, as well as the operator's security are guaranteed only when the supplied accessories are used. The measurement probes can include limitation or protective elements, therefore it is forbidden to modify without written agreement from CROPICO.

In case of use under other conditions than the one specified in this manual, the safety of the user will be in danger.

## MEANING OF THE DIFFERENT SYMBOLS ON THE INSTRUMENT

	Warning (See document attached)
	Warning, risk of electric shock.
	DC voltage.
	AC and DC voltages.
	AC voltage.
	Earth connection.

## 1-1 MAIN SPECIFICATIONS:



### 1-1-1 Presentation

- Robust case, dust and water proof.
- Portable device, light in weight and with carrying strap.
- Option: a case to store the unit, its accessories and measurement leads.

### 1-1-2 Functions and specifications

- 4 measurement ranges:  $6\text{m}\Omega$  ,  $60\text{m}\Omega$  ,  $600\text{m}\Omega$  ,  $6000\text{m}\Omega$
- Auto or manual range selection
- Measurement current: 100mA, 1A , 10A
- Impulse current pulse with 100msec. width
- 6000 points LCD display
- Measurement accuracy: +/- (0,1% reading + 0,1% full scale)
- Measurement threshold with adjustable low and high limits
- Alarm beeper
- 999 piece memory with measurement results, date, and time.
- Bi-directional transfers for test sequence and measurement results on a PC under excel format files.
- RS232 serial interface to download data between the DO7010 and a PC.
- Remote Control Unit with LCD display (similar to the DO7010 main unit display) and memory.
- RS232 serial interface for the handshake between the RCU and the DO7010 from 3 up to 15 meters.

### 1-1-3 Power supply

- Removable Nickel METAL ( NiMH ) battery pack; 3 AH Capacity
- External universal battery charger
- 2 charging mode: fast and trickle
- A fully charged battery pack allows 1000 measurements @10A.

- For energy saving the DO7010 switches off the LCD backlight after a time adjustable in the SETUP menu, with automatic switch on when pressing any key. Even without backlight the display stays readable.

## 1-2 TECHNICAL SPECIFICATIONS:

### 1-2-1 Front panel

#### *Main display on the unit:*

- Ø 64 x 240 points LCD matrix (liquid crystal display) with electroluminescent diode backlight.
- Ø 6000 digit measurement and location test point display with large characters and small characters for:
  - units
  - measurement range
  - measurement current
  - battery charge level
  - error code ( measurement, polarity...)

#### *Keyboard:*

- 5 function keys changing according to the menus.
- 4 navigation keys: arrows UP, DOWN, RIGHT, LEFT.
- 1 data enter key
- 1 software power ON key
- 1 mechanical key to trigger the measurement.

#### *Visual and audible signal:*

- Audible signal when pressing keyboard ( can be disabled)
- Audible signal with error message and FAIL measurements
- Red and Green LEDES for PASS/FAIL measurement results.

#### *Measurement connection:*

- 2 circular connectors (3 and 4 pins) with locking system from JAEGER

#### *RS232 interface:*

- sub-D 9 pins connector for PC and RCU connection

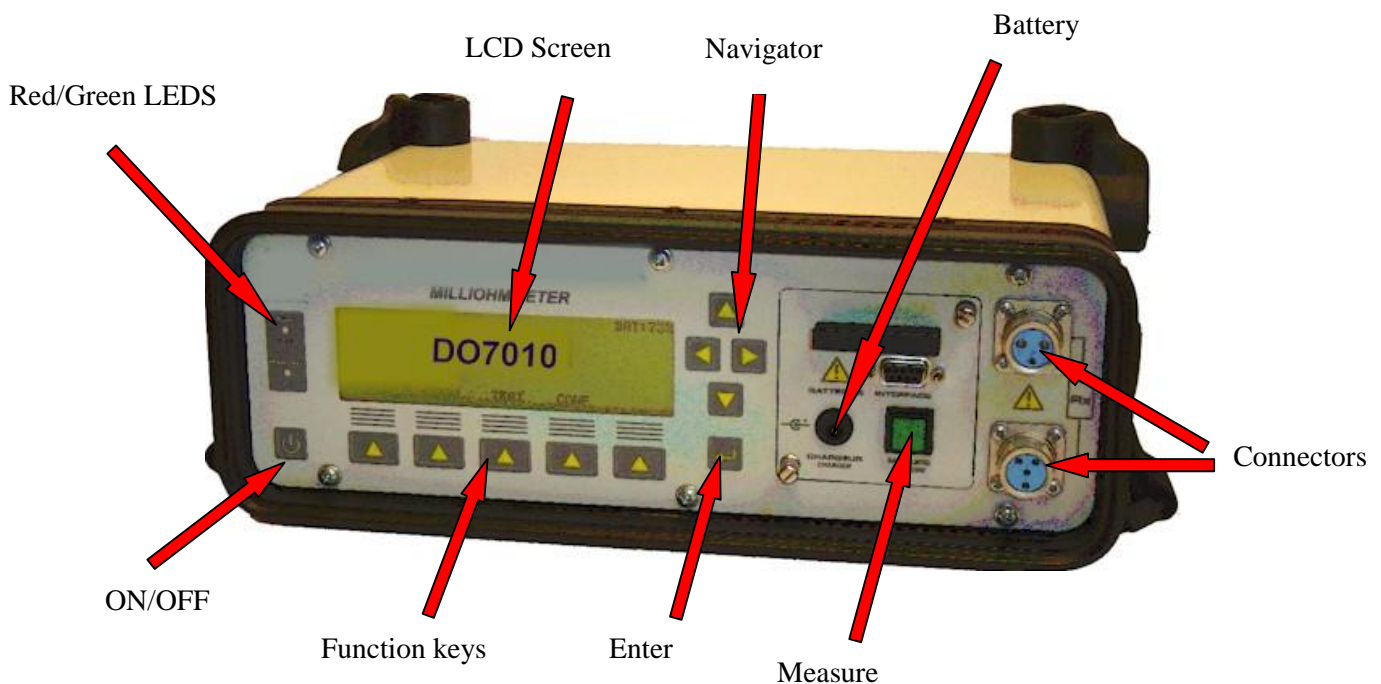

### 1-2-2 Measurement ranges

The DO7010 measuring capacity is made by 4 resistance ranges manually or automatically selected:

<b>Range</b>	<b>Current</b>	<b>Resolution</b>	<b>Accuracy</b>
6m $\Omega$	1A / 10A	1 $\mu\Omega$	(0,1% read + 0,1% FS)
60m $\Omega$	1A / 10A	10 $\mu\Omega$	(0,1% read + 0,1% FS)
600m $\Omega$	1A / 10A	100 $\mu\Omega$	(0,1% read + 0,1% FS)
6000m $\Omega$	0,1A / 1A	1m $\Omega$	(0,1% read + 0,1% FS)

read = reading FS = Full scale

Each measurement range can be operated with 2 currents (high and low currents) selected by the operator. The current generator is permanently controlled by the microprocessor, and an error message is displayed if the current is out of specs. The maximum current value cannot exceed +10% of the rated value.

### 1-2-3 Manual or auto triggering mode

In MANUAL triggering mode, by pressing on the mechanical push button MEASURE, the unit starts a measurement cycle generating a short current pulse and allowing the voltage drop across the resistor to be measured. Using the Ohm's law ( $R = U / I$ ), the unit computes the resistance value and displays the result on the LCD screen.

In AUTO triggering mode, the measurement is triggered by the current flowing through the specimen under test detection.

The triggering mode is set in the SETUP menu.

### 1-2-4 Measurement quality control

- Ø The error cancellation of the thermocouple EMF is done either by the ZERO mode method consisting in a first measurement without current followed by a measurement with current from which unwanted voltages are subtracted, or by the AVERAGE mode method consisting in two measurements with both current polarity and then average of the results.
- Ø The maximum resistance leads for the current connection is 170 m $\Omega$ .
- Ø AUTOTEST is automatically performed at each unit power on, and a calibration check can be done with the TEST function.
- Ø When a measurement default occurs (bad accessory contact, too high resistance for the range, etc...) a warning message, which is clear and easy to understand, is displayed on the LCD screen.



### 1-2-5 SEQUENCE mode

In SEQUENCE mode, the DO7010 is able to store 999 measurements with location number, limit, current, resistance ,date ,time, and operator ID according to a protocol written under an excel file format. The excel file is created on a PC and then downloaded to the DO7010.

Protocol header:

- Operator name : T DURANT
- ID: NT76207521
- Date: 02/10/03
- Plane no: 1234567

Each protocol line includes:

- Mechanical drawing no: 1234567890
- Bounding no: 23
- Threshold value: 5m $\Omega$
- Measurement current : 1 or 10A
- Measurement value: 4,99m $\Omega$

This data is saved even when the main battery pack is fully discharged, and when replacing the battery pack.

The keyboard allows you to quickly select the functions, search for the points to be measured, scrolling the screen pages, etc...

### 1-2-6 RS232 serial interface:

The DO7010 comes, as standard, with an RS232 serial interface with the following specifications:

- ANSI/EIA/TIA-232-E61991 specs.
- Baud rate : 9600 bauds
- Start bit : 1
- Bit number : 8
- Parity check : no
- Stop bit : 1

Using the RTS and CTS 5 wires mode provides a hardware synchronisation of the serial interface.

The commands to control the unit and the SEQUENCE download are in accordance with the IEEE488-2 standard and follow the SCPI language rules.

### 1-2-7 Power supply

The DO7010 is powered by an easily removable NiMH battery pack. Operating time is about 20 hours, or 1000 measurements @ 10A. Visual information on the LCD screen with a numerical value in %, gives the battery discharge level. Plugged in the DO7010 or outside of the DO7010, the battery pack can be recharged with the provided charger connected to the mains (90 -250 volts). The charge control is fully automatic, and the charge time is less or equal to 3 hours. Additional battery packs can be purchased separately (DO7010-02)

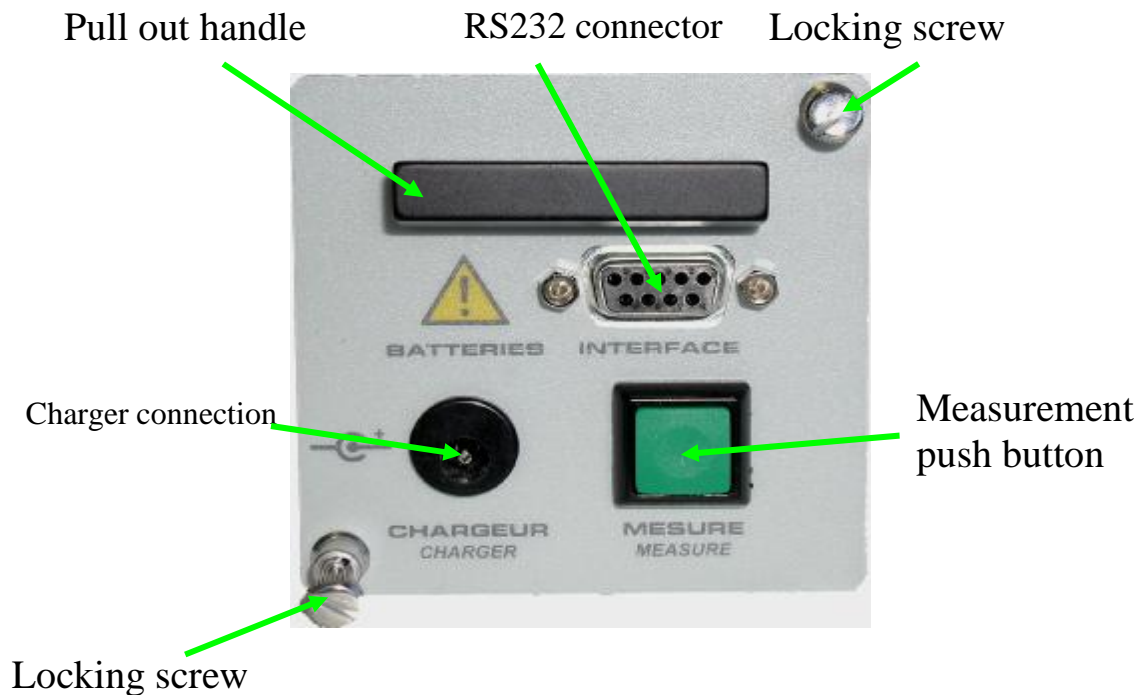

### 1-2-8 Unit Dimensions

The DO7010 is presented in a grey polyurethane case.

- High : 275mm
- Length : 340mm
- Width : 120mm

### 1-2-9 Weight

< 4.5 kg

## **1-2-10 Remote Control Unit (RCU) specifications (DO7010-REM)**

On option, the DO7010 unit can work in conjunction with a remote control unit (DO7010-REM)

The DO7010 RCU is made in a shock proof black colour polystyrene case. It includes a 64x240 dot matrix graphic LCD screen with backlight, a beeper, red and green LED, a set of 5 function keys and a 4 direction navigator with an enter key.

The RCU also includes a battery back up memory, allowing uploading measurement results in to a PC computer without having to transport the DO7010 main unit.

The RCU is connected to the DO7010 with a 3 meter long cable, which can be extended to 15 meters.

### **RCU dimensions:**

- Length : 200 mm
- Width : 120 mm
- High : 60 mm

### **Weight:**

- 600 g

### **Display:**

64x240 points LCD matrix (liquid crystal display) with electroluminescent diode backlight.

6000 digit measurement and location test point display in large and small characters for:

- unity
- measurement range
- measurement current
- battery charge level
- Error code (measurement, polarity...)

### **Keyboard:**

- 5 function keys changing according to the menus.
- 4 navigation keys: arrows UP, DOWN, RIGHT, LEFT.
- 1 data enter key
- 1 software power ON key
- 1 mechanical key to trigger the measurement.

### **Visual and audible signal:**

- Audible signal when pressing keyboard ( can be disabled)
- Audible signal with error message and FAILED measurements
- Red and Green LEDS for PASS/FAIL measurement results.

### **Battery charge level:**

From 0 to 99%

### **Operation:**

The RCU can be operated either by hand, or strapped to the fore arm to make the measurement easier.

### 1-2-10-1 Data transfer between PC and the Remote Control Unit (RCU):

The DO7010 unit and the RCU (DO7010-REM option) exchange data through a serial RS232 interface.

When the RCU is connected to the DO7010 (with a special cable DO7010-262 provided by CROPICO), the whole control is done from the RCU.

The memorisation of the protocol as well as the measurement results are made in the RCU memory.

When the measurement protocol (complete or partial) is over, the connection cable between the DO7010 and the RCU can be disconnected (on the RCU side). The operator brings the RCU to the data storage PC computer equipped with the DO7010-08 option (RCU/PC adaptor with power supply).

The RCU is connected on the DO7010-08 and the DO7010-PRO software (DO7010-09 option) allows RCU memory transfer into the PC computer.

Then the RCU memory can be cleared and downloaded with a new measurement protocol.

After RCU re-connection to the DO7010 main unit the device is ready to perform the new measurement protocol.

### 1-2-10-2 Remote Control Unit presentation :



### **1-2-11 Data transfer between PC computer and the RCP2A**

The DO7010 unit and the PC exchange data through a serial RS232 interface, with a special cable DO7010-179A provided with DO7010-PRO software (DO7010-09 option).

The operator brings the DO7010 to the data storage PC computer, equipped with the DO7010-179A cable, and downloads a measurement sequence into the DO7010 memory.

The memorisation of the protocol as well as the measurement results are done in the DO7010 unit.

Then, the operator brings the DO7010 into the production area and executes all the measurements.

When the measurement protocol (complete or partial) is over, the operator brings the DO7010 to the data storage PC computer equipped with the DO7010-179A cable.

The DO7010 unit is connected to the DO7010-179A and the DO7010-PRO software (DO7010-09 option) allowing DO7010 memory transfer into the PC computer.

Then the DO7010 memory can be cleared and downloaded with a new measurement protocol.

**1-2-12 Wiring synoptic between PC, DO7010 and DO7010-REM**

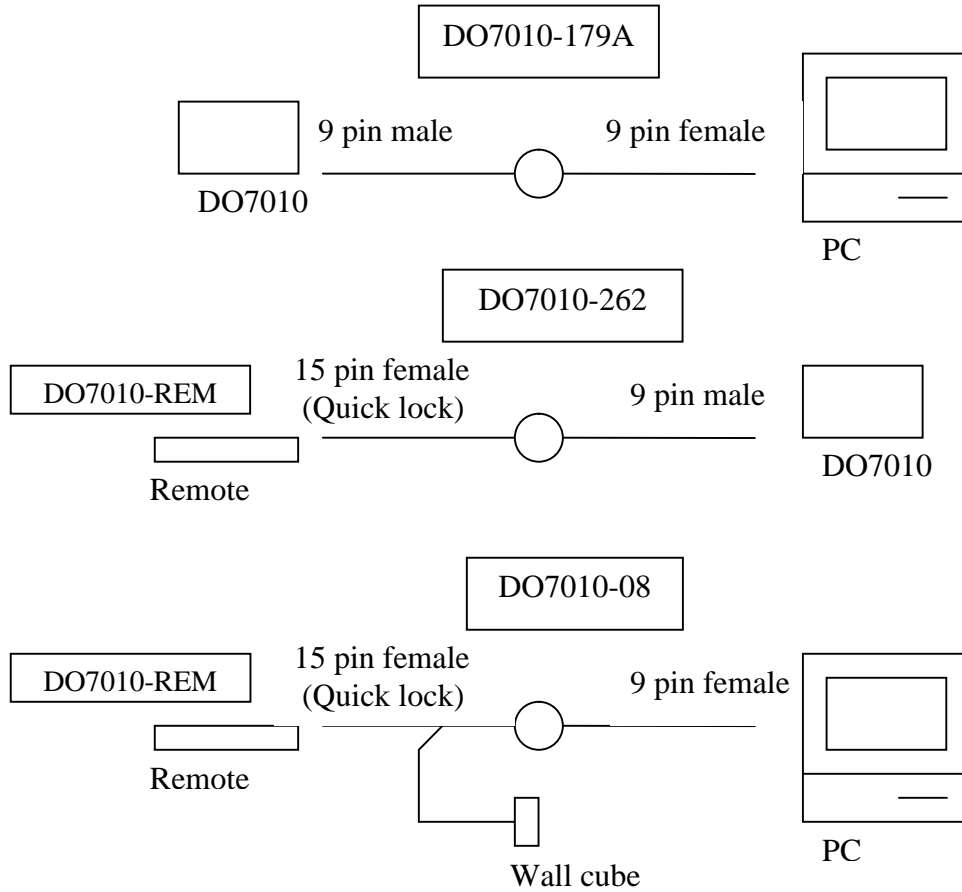

### 1-3 OPTIONS and ACCESSORIES:

* DO7010-REM	Remote Control Unit (RCU) with memory
* DO7010-02	Additional battery pack
* DO7010-03	Additional battery charger
* DO7010-04	12 meters extension cable for Remote control unit & measurement leads ( 4pts male/ 4pts female)
* DO7010-05	Fibre glass suitcase for DO7010 & accessories
* DO7010-06	15 meters extension cable on reel (3 pts mâle/3 pts female)
* DO7010-07	90 meters extension cable on reel with wheels (3 pts mâle/3 pts female)
* DO7010-08	RCU / PC adaptor with power supply
* DO7010-09	DO7010-PRO software and PC connection cable
* DO7010-10	20 meters extension cable on reel with 3 pts male/ 3pts male
* DO7010-11	20 meters extension cable on reel with 3 pts male/ 3pts female
* DO7010-13	Battery charger with power cord
* DO7010-14	Jaeger adaptor 3 pins male to 4 pins female
* DO7010-15	Protection lid
* DO7010-16	Bag for RCP2A accessories
* DO7010-17	Shunt 1 m $\Omega$ 0.5 % for DO7010
* DO7010-18	Shunt 5 m $\Omega$ 0.5 % for DO7010
* DO7010-19	Shunt 10 m $\Omega$ 0.5 % for DO7010
* DO7010-20	Shunt 50 m $\Omega$ 0.5% for DO7010
* DO7010-21	USB serial adapter to add a serial port on a PC
* DO7010-91	Calibration box for DO7010

### Lead and probes:

D07010-250	4 wire lead with banana plugs and tips ( VN-VG)
DO7010-251	2 wire probe , 4 pins male plug , concentric tips , length = 150mm
DO7010-255	2 wire lead , 3 pins male plug , Kelvin crocodile clip
DO7010-258	2 wire probe , 4 pins male plug , concentric tips , length = 180mm
DO7010-28/1	2 wire probe , 4 pins male plug , parallel tips , length = 180mm , remote control push-button
DO7010-10/1	2 wire lead , 3 pins male plug , large Kelvin crocodile clip

Pictures of some accessories:

**DO7010-258**



**DO7010-255**



**DO7010-28/1**



**DO7010-10**





### 1-3-1 Transportation suitcase DO7010-05

On option (DO7010-05) an ivory cream colour (RAL1015) polyester resin and glass fibre suitcase can be provided.

Dimensions: Length: 660mm  
Width: 460mm  
High : 180mm

This suitcase allows the transport of the following accessories:

- Milliohmmeter DO7010
- Spare battery pack DO7010-02
- External universal battery charger DO7010-03
- 2 wire lead , 3 pins male plug , Kelvin crocodile clip
- 2 wire probe , 4 pins male plug , concentric tips , length = 150mm
- Remote Control Unit DO7010-REM

### *SUITCASE PRESENTATION*



## 1-4 MEASUREMENT METHOD:

In order to perform high accuracy low resistance measurements, the DO7010 uses a 4 wire method named Kelvin method.

- 2 wires are used to connect a constant current source to the specimen under test
- 2 wires are used to measure the voltage difference directly on the specimen under test terminals.

With this method the measurement leads resistance doesn't introduce error, but should not exceed 170 mΩ for the current connection.

### Kelvin method

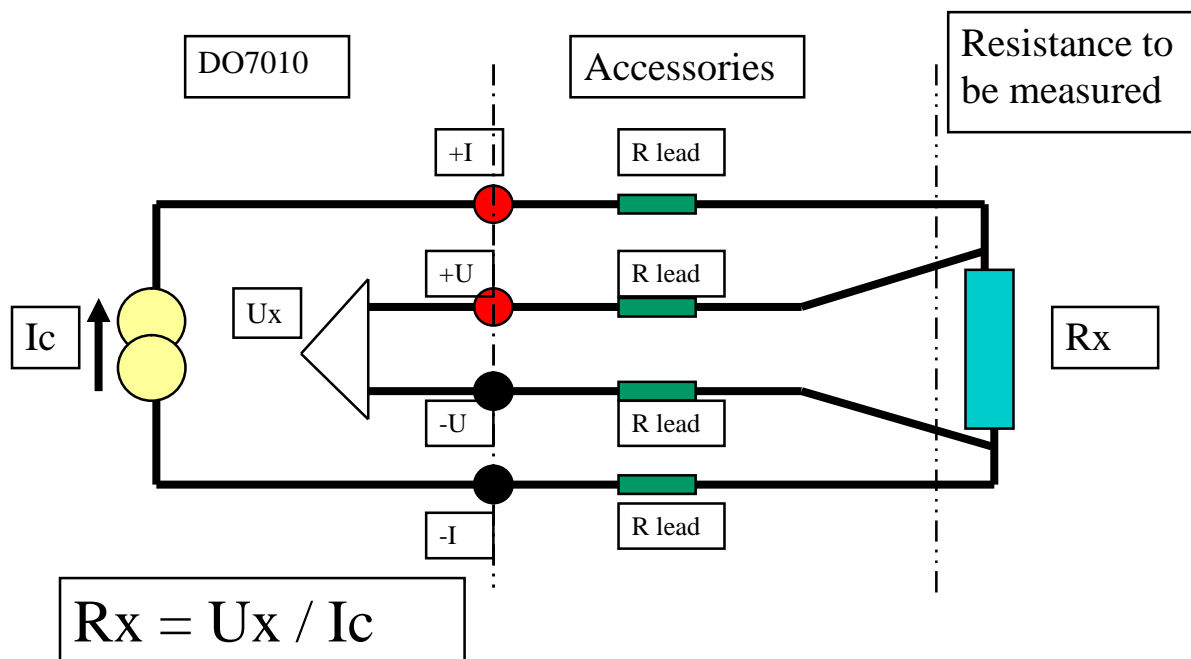

## SECTION 2: BATTERY CHARGER AND ACCESSORIES OPERATION

Switch ON the DO7010 by pressing on the key located on the left hand side corner of the front panel (see chapter 1-2-1 Front panel)

### 2-1 Battery charger operation:



When the battery level indicator gives a value lower than 10%, it is necessary to charge the battery pack or to replace it with a fully charged one.

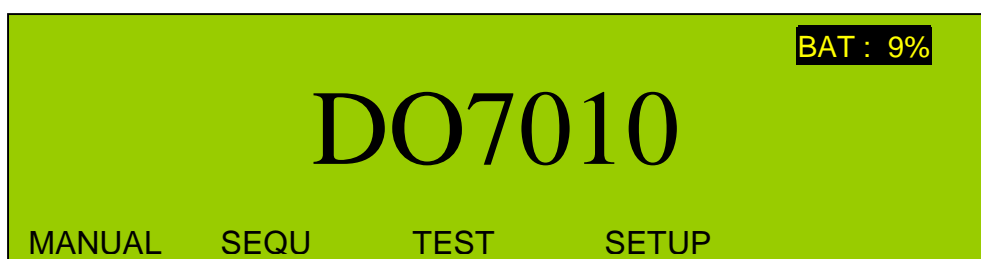

#### 2-1-1 Battery charging in the DO7010:

- Ø  Switch OFF the DO7010 with the ON/OFF key (left hand side on the front panel).
- Ø Connect the charger circular connector in the front panel battery pack terminal named *CHARGER*
- Ø Connect the charger to a mains plug (90- 230 VAC)
- Ø The red lamp on the charger turns on permanently. It will flash to indicate the charge end (< 3 hours)
- Ø Then disconnect the circular connector from the DO7010 front panel.
- Ø Switch ON the DO7010 and check that the battery level gives a value = 99 %

### Red lamp



## 2-1-2 Battery charging outside of the DO7010:

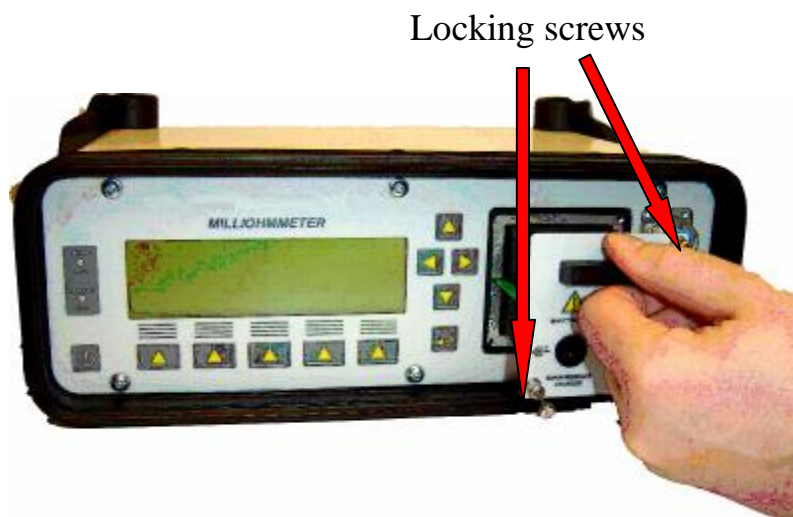

- ⌀  Switch OFF the DO7010 with the ON/OFF key (left hand side on the front panel).
  - ⌀ Unscrew the 2 locking screws and pull out the battery pack with the help of the handle.
  - ⌀ Connect the charger circular connector in the front panel battery pack terminal named *CHARGER*
  - ⌀ Connect the charger to a mains plug (90- 230 VAC)
  - ⌀ The red lamp on the charger turns on permanently. It will flash to indicate the charge end ( < 3 hours)
  - ⌀ Then disconnect the circular connector from the DO7010 front panel.
  - ⌀ Pull in the battery pack and screw the 2 locking screws
- Switch ON the DO7010 and check that the battery level gives a value = 99 %

## 2-2 Accessories connection:



- ⌀ The DO7010 accessories are equipped with 3 or 4 pins JAEGER connectors.
- ⌀ Check the pin number of your accessory and connect it the right plug.
- ⌀ Push the connector into the socket and then rotate the stripped collar  $\frac{1}{4}$  clockwise to lock.

- Ø Turn the stripped collar  $\frac{1}{4}$  anti-clockwise, and pull out the connector to disconnect.

## SECTION 3: DO7010 CONFIGURATION

From the power ON screen or from any menu level which allows the operation, press on the SETUP key to reach the DO7010 setup menu.

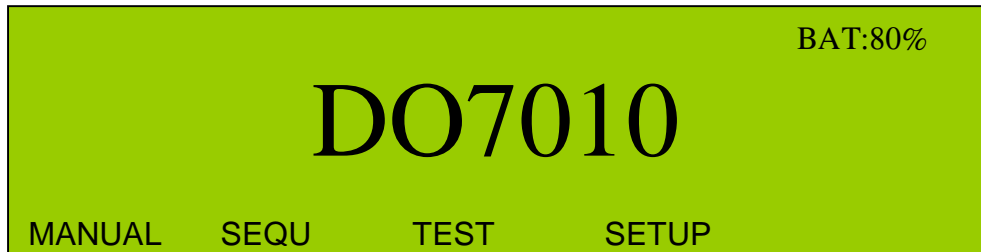

- Φ With the UP and DOWN arrows, move the reverse video area to select the line to modify.
- Φ With the RIGHT arrow or the enter key, enter in the menu level to set the parameters.

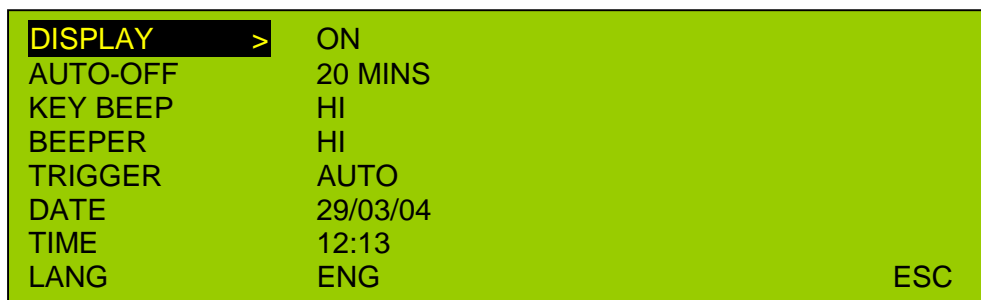

### 3-1 LCD screen setup: the contrast

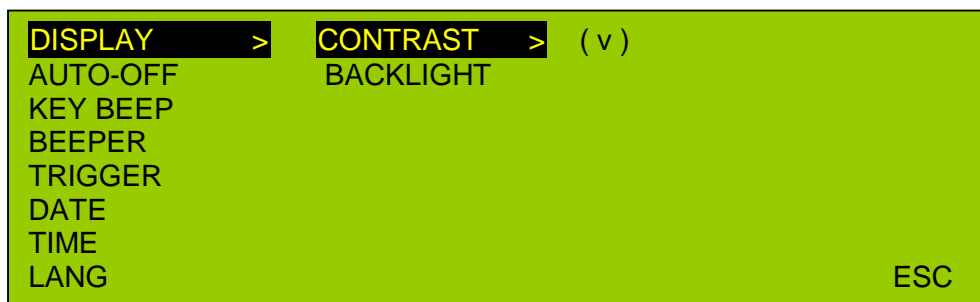

- Φ Select the DISPLAY line
- Φ Press on the RIGHT arrow or on the enter key
- Φ Select the CONTRAST line
- Φ Press on the RIGHT arrow or on the enter key
- Φ Set the LCD contrast according to the environmental light with the UP and DOWN arrows.
- Φ Enter the setup either with the LEFT arrow or the Enter key

### 3-2 LCD screen setup: the backlight

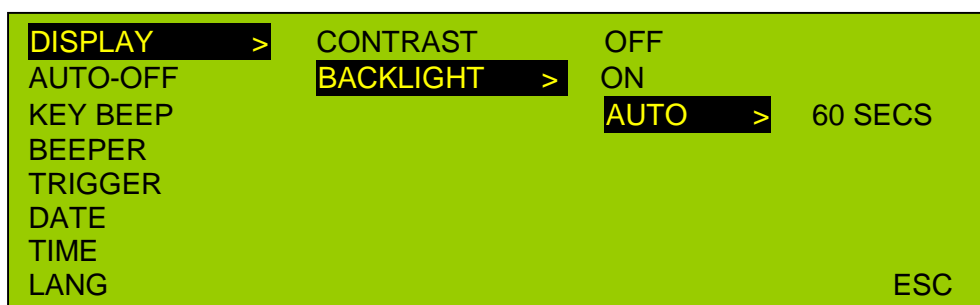

- Φ Select the DISPLAY line
- Φ Press on the RIGHT arrow or on the enter key
- Φ Select the BACKLIGHT line
- Φ Press on the RIGHT arrow or on the enter key
- Φ Select the LED backlight operating mode with the UP and DOWN arrows :
  - ON = permanent (pay ATTENTION to the battery life time! )
  - OFF = without backlight
  - AUTO = set the backlight time from 5 to 60 seconds (by 5 sec. steps) with the RIGHT then UP and DOWN arrows key.
- Φ Enter the setup either with the LEFT arrow or the Enter key
- Φ Press on the LEFT arrow to come back to the previous menu level

### 3-3 Auto switch off mode:

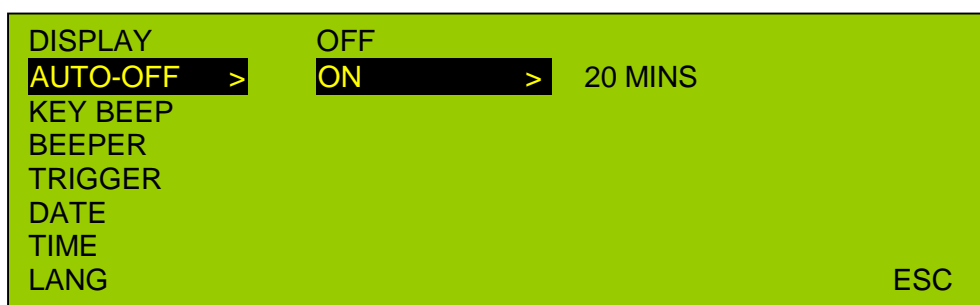

- Φ Select the AUTO-OFF line
- Φ Press on the RIGHT arrow or on the enter key
- Φ Set the automatic switch off mode with the UP and DOWN arrows:
  - OFF= permanent operation mode (pay ATTENTION to the battery life time!)
  - ON = set the time before the unit switch off from 10 to 60 minutes with the RIGHT arrow and then the UP and DOWN arrows.
- Φ Enter the setup either with the LEFT arrow or the Enter key
- Φ Press on the LEFT arrow to come back to the previous menu level

### 3-4 Keys sound level:



- Φ Select the KEY BEEP line
- Φ Press on the RIGHT arrow or on the enter key
- Φ Set the keys sound level with the UP and DOWN arrows:
  - OFF = no sound when pressing a key
  - LO = low sound level.
  - HI = high sound level
- Φ Enter the setup either with the LEFT arrow or the Enter key



### 3-5 Alarm sound level:



- Φ Select the BEEPER line
- Φ Press on the RIGHT arrow or on the enter key
- Φ Set the alarm sound level with the UP and DOWN arrows:
  - OFF = no sound when error or failed result
  - LO = low alarm sound level.
  - HI = high alarm sound level
- Φ Enter the setup either with the LEFT arrow or the Enter key

### 3-6 Measurement trigger mode:

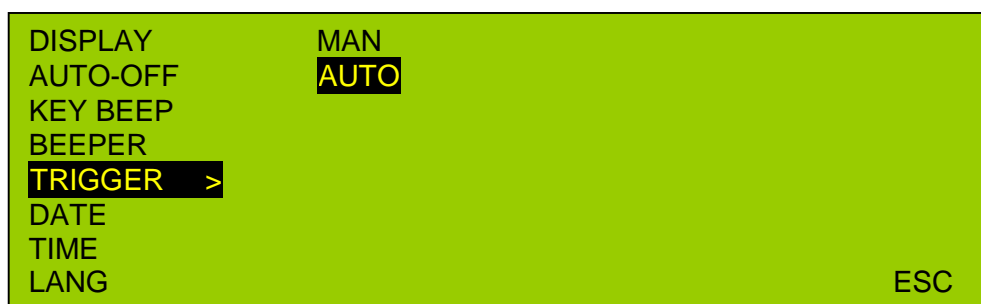

- Φ Select the TRIGGER line
- Φ Press on the RIGHT arrow or on the enter key
- Φ Set the measurement trigger mode with the UP and DOWN arrows:
  - MAN = measurement trigger by the front panel green push button (MEASURE)
  - AUTO = automatic measurement trigger by detection of 100mA current flowing through the specimen under test, then current pulse according to the current setup.
- Φ Enter the setup either with the LEFT arrow or the Enter key

### 3-7 Date setup:

DISPLAY	ON	
AUTO-OFF	20 MINS	
KEY BEEP	HI	
BEEPER	HI	
TRIGGER	AUTO	
<b>DATE</b>	29/03/04	>
TIME	12:13	
LANG	ENG	ESC

- Φ Select the DATE line
- Φ Press on the RIGHT arrow or on the enter key
- Φ Set the Day with the UP and DOWN arrows.
- Φ Move to the Month field with RIGHT arrow.
- Φ Set the Month with the UP and DOWN arrows.
- Φ Move to the Year field with RIGHT arrow.
- Φ Set the Year with the UP and DOWN arrows.
- Φ Enter the setup with the enter key.

### 3-8 Time setup:

DISPLAY	ON	
AUTO-OFF	20 MINS	
KEY BEEP	HI	
BEEPER	HI	
TRIGGER	AUTO	
DATE	29/03/04	
<b>TIME</b>	12:13	>
LANG	ENG	ESC

- Φ Select the TIME line
- Φ Press on the RIGHT arrow or on the enter key
- Φ Set the Hour with the UP and DOWN arrows.
- Φ Move to the Minute field with RIGHT arrow.
- Φ Set the Minute with the UP and DOWN arrows.
- Φ Enter the setup with the enter key.

### 3-9 Language selection:



- Φ Select the LANG line
- Φ Press on the RIGHT arrow or on the enter key
- Φ Set the language with the UP and DOWN arrows:
  - ENG = English
  - FRA = Français (French)
  - DEU = Deutsch (German)
- Φ Enter the setup either with the LEFT arrow or the Enter key

### 3-10 Mains frequency selection:

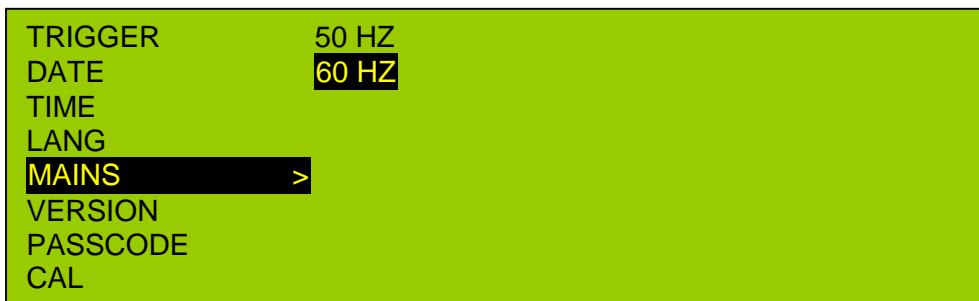

- Φ With the DOWN arrow, scroll the reverse video area on the underneath lines
- Φ Select the MAINS line
- Φ Press on the RIGHT arrow or on the enter key.
- Φ Select the mains frequency to optimize the measurement stability with the UP and DOWN arrows:
  - 50HZ = for 50 and 400Hz
  - 60HZ = for 60Hz
- Φ Enter the setup either with the LEFT arrow or the Enter key

### 3-11 Calibration access code:

TRIGGER	AUTO
DATE	29/03/04
TIME	12:13
LANG	FRA
MAINS	50HZ
VERSION	VER 1.0
<b>PASSCODE</b>	<b>&gt;</b>
CAL	

- Φ With the DOWN arrow, scroll the reverse video area on the underneath lines
- Φ Select the PASSCODE line
- Φ Press on the RIGHT arrow or on the enter key.
- Φ Enter your previous calibration passcode with the UP, DOWN, RIGHT, LEFT arrows.
- Φ Enter the passcode with the Enter key
- Φ Then enter your new passcode with the UP, DOWN, RIGHT, LEFT arrows.
- Φ Enter the new passcode with the Enter key
- Φ If you don't remember your passcode , please call CROPICO's service department on +44 (0) 208 684 4025
- Φ Enter the setup either with the LEFT arrow or the Enter key

To perform a unit calibration, please refer to the Calibration manual.

### 3-12 DO7010 AUTOTEST:

At anytime the DO7010 auto-test function allows checking the current generator and measurement correct operation.

From the initialization menu, press on the TEST function key:

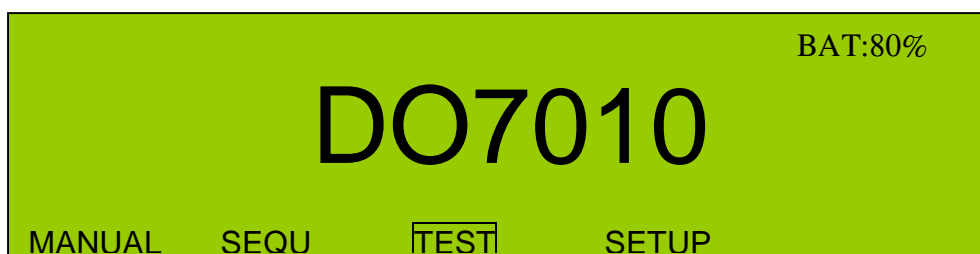

Then the DO7010 performs a checking routine and display the measurement result of a built-in 5 mΩ resistor.

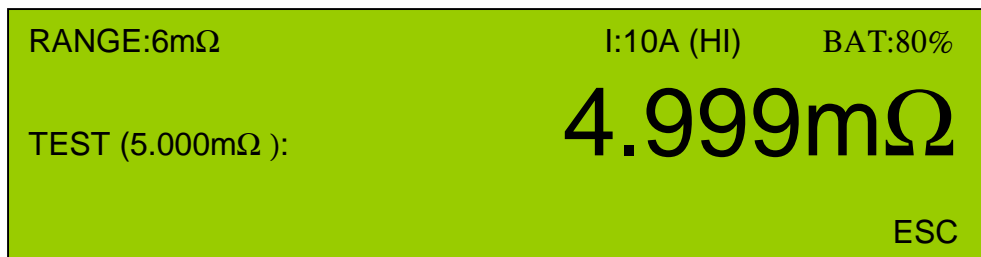

If the measurement result is within the tolerances (uncertainty of DO7010 unit + built-in resistor equal about +/- 19 digits) then the green LED lights, if not the red LED lights.

If red LED lights, we recommend to stop operating the unit and to send it back to our Service department for diagnostic.

## SECTION 4: OPERATING THE DO7010 IN MANUAL MODE

The DO7010 MANUAL operating mode allows performing single measurement as any ordinary measurement unit.

In addition the DO7010 SEQUENCE operating mode performs measurement sequence according to saved protocol through PC download (see section 5)

From the power ON screen, press on the MANUAL function key to reach the MANUAL menu.

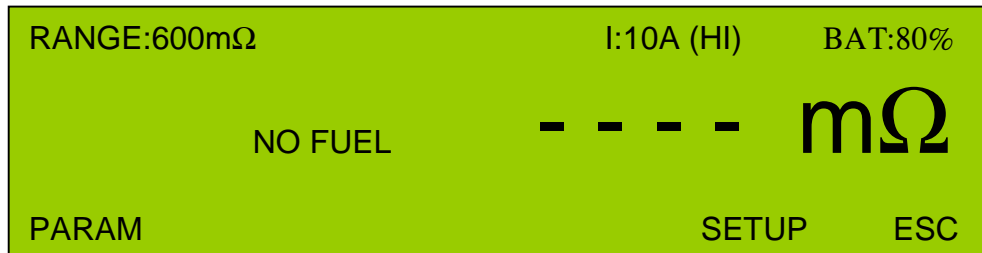

- Φ The LCD screen upper line gives range and current parameters.
- Φ After each power ON, those parameters will be reset to default values (60mΩ, 10A, ZERO mode ) or memorized (according to manufacture setup).
- Φ The **NO FUEL** message is displayed (according to manufacture setup) for current values :1A and 10A

### 4-1 MANUEL mode parameters:

- Φ To change the measurement ranges, press on the UP or DOWN arrows.
- Φ To change the other parameters, press on the PARAM function key.

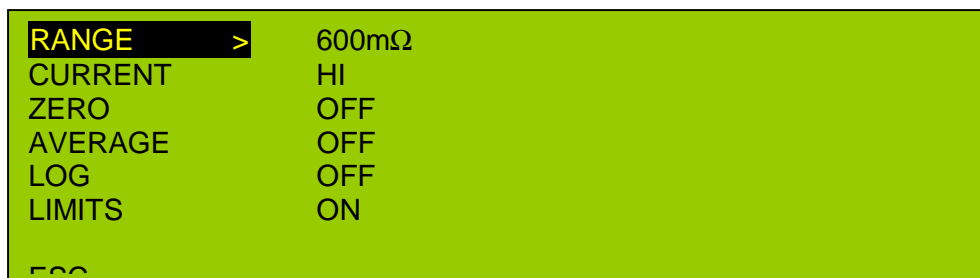

- Φ With the UP and DOWN arrows, move the reverse video area to select the line to modify.
- Φ With the RIGHT arrow or the enter key, enter in the menu level to set the parameters.

#### 4-1-1 Measurement range selection:

<b>RANGE</b>	<b>&gt;</b>	<b>6000mΩ</b>
CURRENT		600mΩ
ZERO		60mΩ
AVERAGE		6mΩ
LOG		AUTO1
LIMITS		AUTO2
		ESC

- Φ Select the RANGE line
- Φ Press on the RIGHT arrow or on the enter key .
- Φ Select the measurement range with the UP and DOWN arrows:
  - Ø 6000mΩ : from 0001 to 6000 mΩ
  - Ø 600mΩ : from 000.1 to 600.0 mΩ
  - Ø 60mΩ : from 00.01 to 60.00 mΩ
  - Ø 6mΩ : from 0.001 to 6.000 mΩ
  - Ø AUTO1 : automatic searching range from the last measurement range.
  - Ø AUTO2 : automatic searching range from the highest range (6000mΩ )
- Φ Enter the selection with the Enter key.

#### 4-1-2 Measurement current selection:

RANGE		LO
<b>CURRENT</b>	<b>&gt;</b>	<b>HI</b>
ZERO		
AVERAGE		
LOG		
LIMITS		
ESC		

- Φ Select the CURRENT line
- Φ Press on the RIGHT arrow or on the enter key.
- Φ Select the measurement current with the UP and DOWN arrows:
  - Ø HI = 10A for the 6 to 600mΩ ranges and 1A for the 6000 mΩ range.
  - Ø LO = 1A for the 6 to 600mΩ and 0.1A for the 6000 mΩ range.
- Φ Enter the selection with the Enter key.

### 4-1-3 Thermocouple error:

Putting in contact 2 metals from different material generates unwanted voltages (EMF) proportional to the ambient temperature.

When measuring low resistances, consequently low voltages, the accessories and specimen under test conductive metals can introduce important errors.

Two methods exist to cancel this problem: the Zero method and the Average method. Those 2 methods are available with the DO7010.

*The ZERO method:*



- Φ Select the ZERO line
- Φ Press on the RIGHT arrow or on the enter key.
- Φ The Zero method consists in a voltage measurement without current, then a voltage measurement with current and subtraction of EMF voltages before resistance calculation. Select with the UP and DOWN arrows:
  - ON = Zero method operating
  - OFF = Zero method not operating
- Φ Enter the selection with the Enter key.

*The AVERAGE method:*



- Φ Select the AVERAGE line
- Φ Press on the RIGHT arrow or on the enter key.
- Φ The Average method consists in a voltage measurement with a positive current, then a voltage measurement with negative current and average of the 2 measurements to get the resistance calculation. Select with the UP and DOWN arrows:
  - ON = Average method operating
  - OFF = Average method not operating
- Φ Enter the selection with the Enter key.



#### 4-1-4 Log mode:

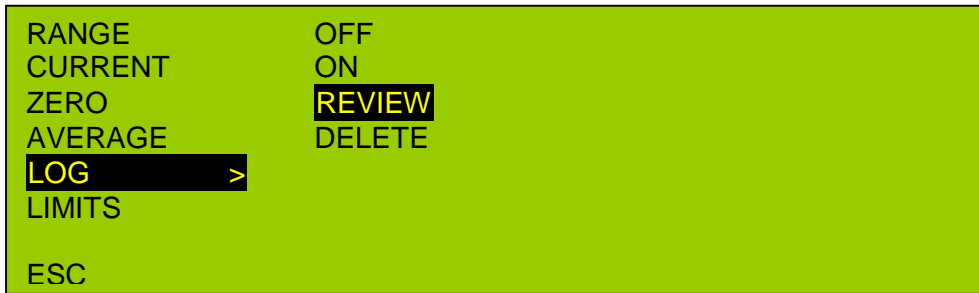

- Φ Select the LOG line
- Φ Press on the RIGHT arrow or on the enter key.
- Φ When the SEQUENCE mode is empty (no Sequence downloaded in the DO7010), the MANUAL mode allows storing up to 999 measurements with the measurement number, the resistance value, the current, the range, the time and the date.
- Φ Select the Log mode with the UP and DOWN arrows:
  - OFF = no log mode
  - ON = log mode operating if no sequence loaded
  - REVIEW = to review the already stored values
  - DELETE = to delete the memory
- Φ Enter the selection with the Enter key.

LOG#	Rx	RANGE	I	DATE	TIME

#### 4-1-5 The limit function:

On the DO7010 in MANUAL mode a maximum and the minimum resistance values can be adjusted.

Within those 2 values, the measurement is correct (PASS), the green LED lights and the OK message is displayed on the LCD screen.

For values higher than the maximum limit or lower than the minimum limit the measurement is failed (FAIL), the red LED lights, a beep signal sounds and the message “HI” or “LO” is displayed on the LCD screen.

*Limits adjustment:*

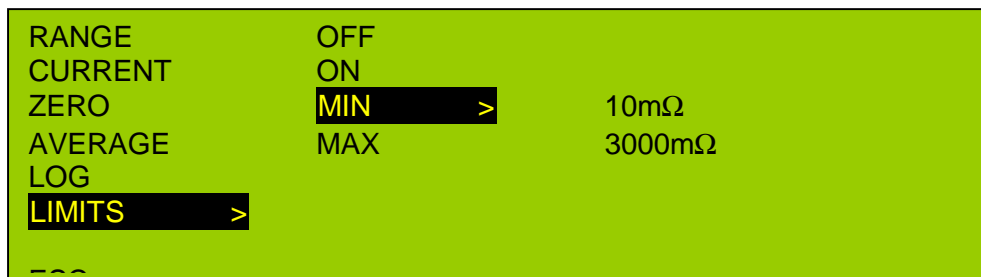

- Φ Select the LIMITS line
- Φ Press on the RIGHT arrow or on the enter key.
- Φ Select the Limits mode and values with the UP and DOWN arrows:
  - OFF = limit function not operating
  - ON = limit function operating
  - MIN = adjust the minimum value from 0.001 to 6000 mΩ with the RIGHT arrow and then with the UP or DOWN arrows.
  - MAX = adjust the minimum value from 0.001 to 6000 mΩ with the RIGHT arrow and then with the UP or DOWN arrows.
- Φ Enter the selection with the Enter key.
- Φ Press on the LEFT arrow to come back to the previous menu level

## 4-2 Measurements in MANUAL mode:

- Φ Trigger a measurement with the green push button on the battery pack front panel, or by making contact on the specimen under test with the probes (see trigger modes in section 3-6)
- Φ If measurement probes or leads are not correctly connected to the specimen under test, the following error messages can be displayed :
  - “**CIRCUIT INCOMPLETE CHECK +VE CABLES**”
  - “**CIRCUIT INCOMPLETE CHECK -VE CABLES**”
  - “**+I RESISTANCE TOO HIGH**”



## 4-3 Measurements in MANUAL mode with the limit function:

- Φ Set the LIMITS mode (see chapter 4-1-5) and trigger a measurement with the green push button on the battery pack front panel, or by making contact on the specimen under test with the probes.
- Φ If the measurement result is :
  - Within the limits, the display shows : **OK**
  - Lower than the low limit, the display shows : **LO**
  - Higher than the high limit, the display shows : **HI**

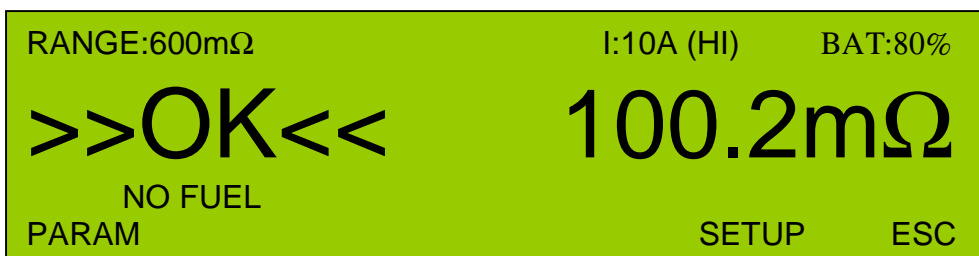

## 4-4 Measurement in MANUAL mode with the log mode:

**WARNING:** this feature is only available if there is no Sequence downloaded in the DO7010 (see chapter 5). To delete the loaded sequence; please refer to the DO7010-PRO software manual.

- Φ Set the Log mode (see section 4-1-4) and trigger a measurement with the green push button on the battery pack front panel, or by making contact on the specimen under test with the probes.
- Φ Each of the measurements will be stored together with the range, current, date, and time.
- Φ To review the measured values:
  - Press on the PARAM function key
  - Select the LOG line
  - Press on the Enter key
  - Select the REVIEW line
  - Press on the Enter key
  - The LCD screen shows the values as follows:

LOG#	Rx	RANGE	I	DATE	TIME
1	10.01	60	HI	19/07/04	13 :14
2	10.03	60	HI	19/07/04	13 :15
3	10.01	60	HI	19/07/04	13 :16
4	10.05	60	HI	19/07/04	13 :17
5	10.01	60	HI	19/07/04	13 :18

- Scroll the values with the DOWN or UP arrows.
- Escape this menu with the ESC function key.

To delete the whole saved measurements:

- Press on the PARAM function key
- Select the LOG line
- Press on the Enter key
- Select the DELETE line
- Press on the Enter key
- Confirm the delete by selecting the CONFIRM line
- Press on the Enter key.
- Select the CANCEL line to stop delete operation
- Press on the Enter key

## SECTION 5: SEQUENCE MODE

The measurement protocols are made with the DO7010 software. This software operates on a PC computer with Excel format files. Files are downloaded in the DO7010, then after complete or partial measurement performing, the files with the measurement data are uploaded from the DO7010 to the PC computer.

File example with measurement protocol description:

<b>MSM aeroplane</b>	AV 1234567								
<b>Reference</b>	A6/789								
<b>Range</b>	<b>Number</b>	<b>Nominal mOhm</b>	<b>Current (A)</b>	<b>Measurement value</b>	<b>Result</b>	<b>Date</b>	<b>Time</b>	<b>Operating ID</b>	<b>Serial no.</b>
ABCDE0123456789	1	500,0	10	423,5	Pass	16.12.03	14:00	A6/123	201
	2	500,0	10	438,8	Pass	16.12.03	14:01	A6/123	201
	3	500,0	10	454,1	Pass	16.12.03	14:02	A6/123	201
	4	500,0	10	469,4	Pass	16.12.03	14:05	A6/123	201
	5	500,0	10	484,7	Pass	16.12.03	14:10	A6/123	201
	6	500,0	10	500,0	Pass	16.12.03	14:11	A6/123	201
	7	500,0	10	515,3	Fail	16.12.03	14:12	A6/123	201
	8	500,0	10	530,6	Fail	16.12.03	14:13	A6/123	201
BBCDE0123456789	1	30,00	1	41,23	Fail	16.12.03	15:00	A6/456	201
	2	30,00	1	38,73	Fail	16.12.03	15:02	A6/456	201
	3	30,00	1	36,23	Fail	16.12.03	15:04	A6/456	201
	4	30,00	1	33,73	Fail	16.12.03	15:06	A6/456	201
	5	30,00	1	31,23	Fail	16.12.03	15:08	A6/456	201
	6	30,00	1	28,73	Pass	16.12.03	15:10	A6/456	201
	7	100,0	10	120,5	Fail	16.12.03	15:12	A6/456	201
	8	100,0	10	115,1	Fail	16.12.03	15:14	A6/456	201
	9	100,0	10	109,7	Fail	16.12.03	15:16	A6/456	201
	10	100,0	10	104,3	Fail	16.12.03	15:18	A6/456	201
	11	100,0	10	98,9	Pass	16.12.03	15:20	A6/456	201
	12	100,0	10	93,5	Pass	16.12.03	15:22	A6/456	201
	13	100,0	10	88,1	Pass	16.12.03	15:24	A6/456	201
	14	100,0	10	82,7	Pass	16.12.03	15:26	A6/456	201
	15	100,0	10	9999	Absent	16.12.03	15:28	A6/456	201
	16	100,0	10	8888	Absent	16.12.03	15:30	A6/456	201
CBCDE0123456789	1	500,0	10	7777	No reply				
	2	500,0	10	7777	No reply				
	3	500,0	10	7777	No reply				
	4	500,0	10	7777	No reply				
	5	500,0	10	7777	No reply				

For more information, please refer to the DO7010-PRO software manual

If no Sequence file has been downloaded the following error message is displayed  
« **NO SEQUENCE FILE LOADED** ».

- Φ After sequence file download, and from the initialisation menu, press on the SEQU function key

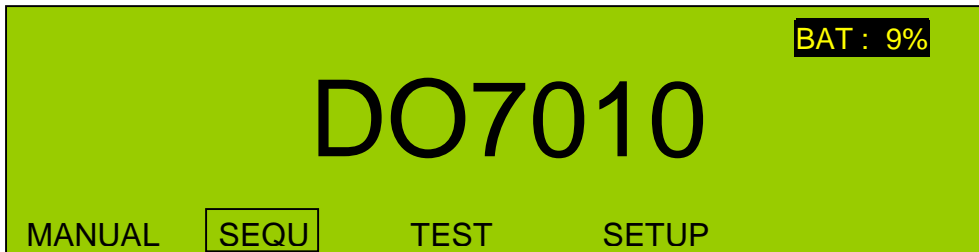

### 5-1 Measurement protocol selection:

A sequence is made with several measurement protocols (or series). Each measurement protocol describes a series of measurements to be performed with the physical location or part number and test parameters (current, resistance threshold) for every test points.

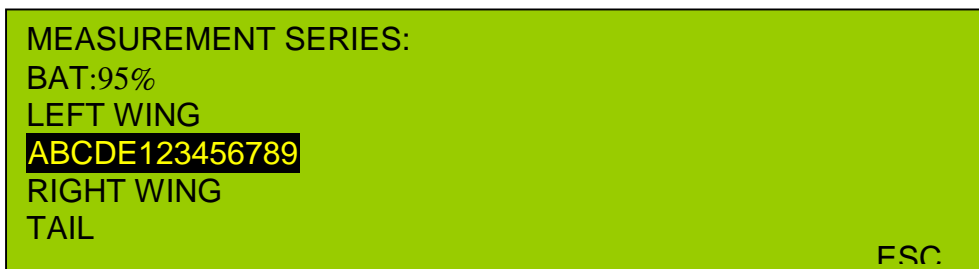

- Φ Select the measurement protocol by setting in reverse video the line with UP or DOWN arrows.
- Φ Enter the selection with the Enter key.

## 5-2 Measurement protocol header display:

```
ABCDE123456789                                BAT:90%
DATE :                04 -12- 03
TIME :                15:35
OPERATOR :          A
AIRCRAFT:            AV1234567
                                                                ESC
```

- Φ Enter the operator code with the UP or DOWN arrows to scroll the numbers and the letters and with the RIGHT or LEFT arrows to select the characters position.
- Φ Enter with the Enter key
- Φ Check the aircraft number, and make correction if necessary with the A/C function key.
- Φ Press on the NEXT function key to start the measurement protocol.

```
ABCDE123456789                                BAT:90%
DATE :                04 -12- 03
TIME :                15:36
OPERATOR :            AB100
AIRCRAFT:            AV1234567
OPER   A/C           NEXT
                                                                ESC
```

## 5-3 First measurement of the protocol:

```
ABCDE123456789      S:150.0mΩ   I:10A
                    BAT:90%
001: - - - - mΩ
POINT   ABSENT   VALID   SET UP   ESC
```

- Φ Trigger a measurement with the green push button on the battery pack front panel or by making contact on the specimen under test with the probes.
- Φ **IMPORTANT:** in AUTO trigger mode, it is mandatory to have first an open circuit, then to make a contact with the probe on the specimen under test to trigger a measurement.

### 5-3-1 Example for a PASS measurement:

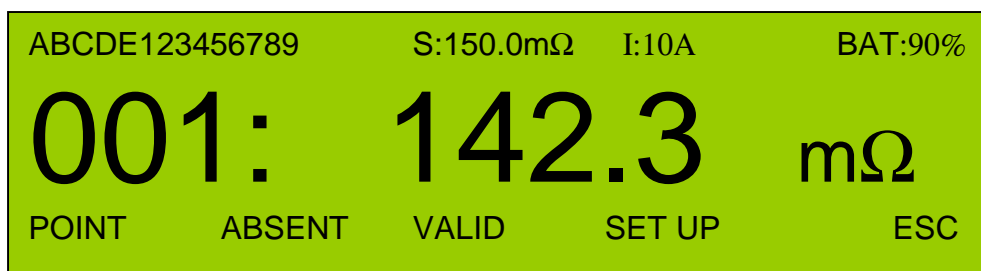

If the measurement is lower than the limit, the green LED lights, the value is saved in the memory and the unit jumps automatically to the next protocol step.

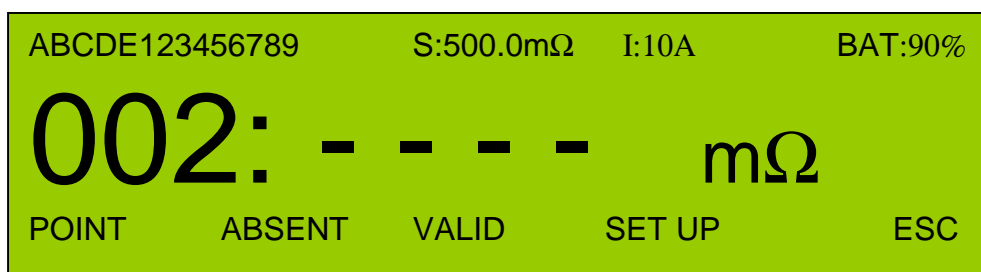

- Φ The next measurement is the next protocol step which is either :
  - To Be Done = - - - - (= 7777 excel file)
  - Over = OVER (= 8888 excel file)
  - Absent = ABS (= 9999 excel file)
  - Fail = previous fail measurement
- Φ The PASS measurements are skipped.

### 5-3-2 Direct access to a test step:

- Φ Press on the POINT function key to set in flashing mode the point number enter area.
- Φ Enter the point number with the UP or DOWN arrows to scroll the numbers and with the RIGHT or LEFT arrows to select the position.
- Φ Enter the value with the Enter key.
- Φ For a direct access to the first sequence point or to the last sequence point, use the RIGHT or LEFT arrows.
- Φ **The direct access feature allows the operator to reach all the sequence points whatever their status (PASS,FAIL,TO BE DONE, ABSENT)**



### 5-3-3 Example for a FAIL measurement:

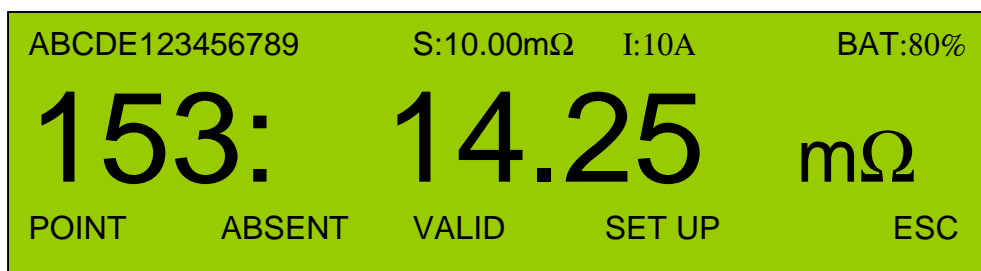

- Φ Trigger a new measurement.
- Φ If the value is higher than the limit, an audible signal (2 beeps) sounds, the red LED lights, and the DO7010 unit stays on the same test step.
- Φ To re-test, trigger a new measurement either with the probe contact or the green front panel push button.
- Φ To store a FAIL measurement, press on the VALID function key.
- Φ Confirm the validation by pressing on the YES function key.
- Φ Then the DO7010 unit jumps to the next test step.
- Φ To cancel the FAIL confirmation, press on the NO function key and trigger a new measurement.

### 5-3-4 Example for an ABSENT point:

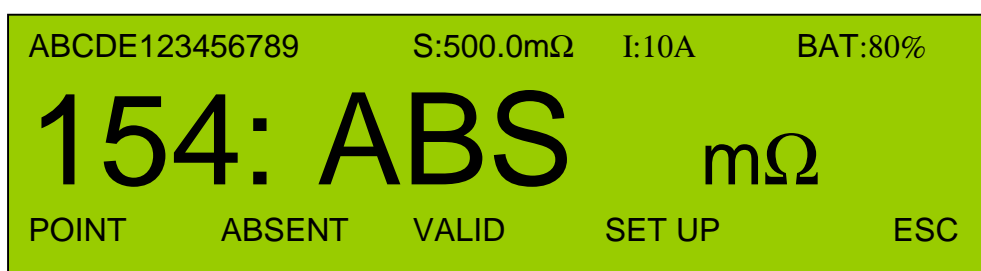

- Φ If a point to be measured is absent or non available for the measurement, then press on the ABSENT function key.
- Φ Confirm the ABSENT status by pressing on the YES function key.
- Φ Then the unit jumps to the next test step.
- Φ To cancel the ABSENT confirmation, press on the NO function key and trigger a new measurement.

### 5-3-4 Example of an OVER measurement:

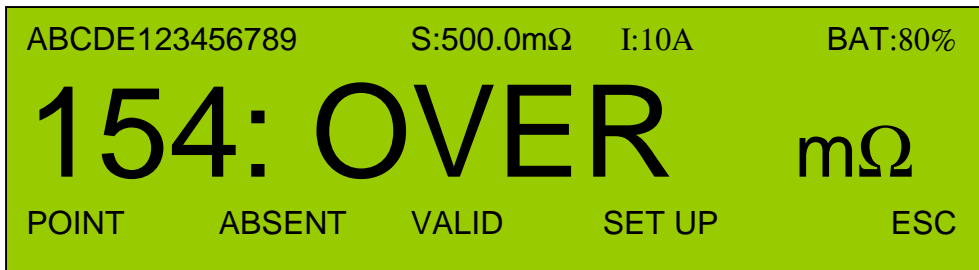

- Φ If the measurement is out of the unit ranges, an audible signal sounds, the red LED lights with above display.
- Φ To re-test, trigger a new measurement either with the probe contact or the green front panel push button.
- Φ To store the OVER status, press on the VALID function key.
- Φ Confirm by pressing on the YES function key.
- Φ Then the unit jumps to the next test step.
- Φ To cancel the OVER confirmation, press on the NO function key and trigger a new measurement.

### 5-4 Sequence end:

After the last sequence measurement, the END message is displayed.  
Press on the END function key to select the next measurement protocol.

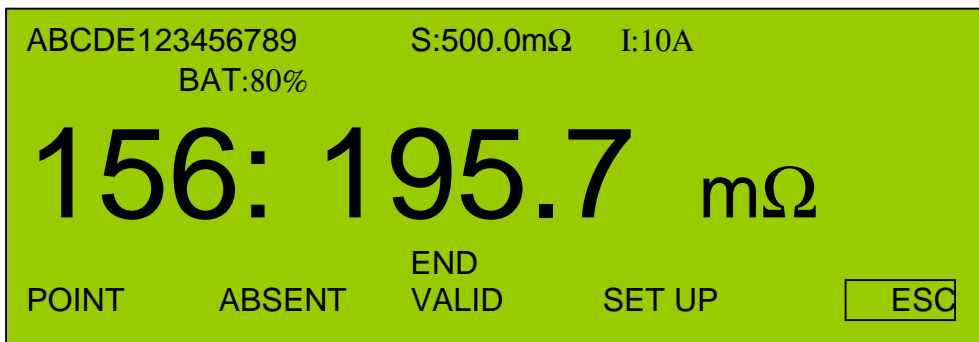

## **SECTION 6 MAINTENANCE and CALIBRATION:**

### ***6.1 PRELIMINARY***

Our warranty (refer to the beginning of this manual) attests the quality of materials and workmanship in our products. If malfunction should be suspected or other information be desired, call our technical assistance: +44 (0) 208 684 4025.

### ***6.2 INSTRUMENT RETURN***

Before returning an instrument to our Service Department, please contact us for shipment instructions. Use packaging that is adequate to protect it from damage.

### ***6.3 MAINTENANCE***

Our units don't need particular maintenance, except an annual calibration. If you encounter any problems, please follow the brief check list here after. If the problem continues, please contact our service department.

- **LCD SCREEN DOESN'T COME UP:**
  - Check that the battery block is correctly fitting into the DO7010 unit.
  - Recharge the battery block for at least 3 hours.

The other possibilities for a bad functioning need an intervention inside the unit by qualified people. However we can supply a service manual including schematics of our units. Please get in contact with our Service department in order to know price and delivery time.

### ***6.4 CLEANING***

Clean the instrument with a damp rag.

### ***6.5 CALIBRATION***

We recommend calibrating our units each year. The calibration must be performed by qualified people following the appropriate procedure as correct standards. Our Maintenance department is at your service to perform the annual calibration. Please contact us to request cost and return times.