

USE AND MAINTENANCE



S6000

Gas Analyzer

1.0	IMPORTANT INFORMATION	06
1.1	Information about this manual	06
1.2	Safety warnings	06
2.0	SAFETY	07
2.1	Intended use of the product	07
2.2	Improper use of the product	07
3.0	WORKING PRINCIPLE	08
3.1	General overview of the Analyzer	08
4.0	DESCRIPTION OF THE PRODUCT	10
4.1	Working principle	10
4.2	Measurement cells	10
4.3	CO dilution	11
4.4	Fuel types	11
4.5	Pressure sensor, piezoelectric, temperature compensated	11
4.6	Gas extraction pump	11
4.7	Simultaneous pressure measurement, O ₂ , pollutants	11
4.8	Smoke measurements	11
4.9	Temperature measurements	11
4.10	Auxiliary measurements	11
4.11	Pressure decay test	11
4.12	Bluetooth® connection	12
5.0	DESCRIPTION OF COMPONENTS	13
6.0	MAIN CONFIGURATIONS	16
7.0	TECHNICAL SPECIFICATIONS	17
7.1	Technical specifications	17
7.2	Measurement and Accuracy Ranges	19
8.0	USING THE FLUE GAS ANALYZER	20
8.1	Preliminary operations	20
8.2	Warnings	20
8.3	Analyzer power supply	21
8.3.1	Checking and replacing the batteries	21
8.3.2	Use with external power pack	21
8.4	QR code generation	21
8.5	Connection diagram	22
8.5.1	Gas Sampling Probe	24
8.5.2	Condensate trap and fine dust filter	24
8.5.3	Connecting the gas sampling probe and water-trap assembly	25
8.5.4	Gas probe for industrial engines	25
8.5.5	Ambient CO probe	26
8.5.6	Combustion air temperature sensor	26
8.5.7	Tc-K temperature measurement probe	26
8.5.8	Ionization current measurement probe	26

8.5.9	Draft measurement	26
8.5.10	Pressure Test Kit	27
8.5.11	Burner pressure verification probe	27
8.5.12	Connection to PC	27
8.5.13	Connection to battery charger	27
9.0	POWER ON - OFF	28
9.1	Starting the device	28
10.0	CONFIGURATION	30
10.1	Configuration Menu	30
11.0	MEMORY	73
11.1	Memory Menu	73
11.1.1	Memory Organization	75
12.0	PRINT	88
12.1	Print Menu	88
13.0	MEASUREMENTS	99
13.1	Measurements Menu	99
14.0	COMBUSTION ANALYSIS	118
14.1	Combustion Analysis	118
14.1.1	Switching on the instrument and auto-calibration	118
14.1.2	Inserting the probe inside the stack	118
14.1.3	Simultaneous pressure measurement, O ₂ , pollutants	119
14.1.4	Flue Gas Analysis	120
14.1.5	End of Analysis	120
14.2	Combustion Analysis - Preliminary operations	121
14.3	Performing the Combustion Analysis - Manual mode	123
14.4	Performing the Combustion Analysis - Data logger mode	125
15.0	SENSORS	127
15.1	Sensors arrangement	127
15.2	Sensor types and relevant positioning	128
15.3	Gas sensors life	128
15.4	Sensor life expectancy table	129
15.5	Expandability to 6 sensors	130
15.6	CxHy sensor for measurement of the unburnt hydrocarbons	131
15.6.1	Installing the CxHy sensor	132
15.7	CO ₂ sensor for Carbon Dioxide measurement in combustion processes	132
15.7.1	Installing the CO ₂ sensor	132
15.8	NH ₃ sensor for ammonia gas measurement in combustion processes	133
16.0	MAINTENANCE	134
16.1	Routine maintenance	134
16.2	Preventive maintenance	134
16.3	Cleaning the sample probe	134
16.4	Maintaining the water trap / filter unit	135

TABLE OF CONTENTS

16.5 Replacing the particulate filter	135
16.6 Replacing the gas sensors	136
16.7 Replacing the battery pack	141
16.8 Replacing the printer paper roll	142
16.9 Firmware update	143
17.0 TROUBLESHOOTING	144
17.1 Troubleshooting guide	144
18.0 SPARE PARTS AND TECHNICAL ASSISTANCE	146
18.1 Spare parts	146
18.2 Accessories	147
18.3 Service Centers	148
ANNEX A - Data Management with “Seitron Smart Analysis” app	149
ANNEX B - Analysis report examples	151
ANNEX C - Coefficients of the fuels and Formulas	154
ANNEX D - Optional measures list	156
WARRANTY CERTIFICATE	159

Seitron Americas Inc. - ALL RIGHTS RESERVED -

Total or partial reproduction of this document by any means (including photocopying or storage on any electronic medium) and transmittal of same to third parties in any manner, even electronically, is strictly prohibited unless explicitly authorized in writing by Seitron Americas Inc.

1.1 Information about this manual

- This manual describes the operation and the characteristics and the maintenance of the Combustion Analyzer S6000.
- Read this operation and maintenance manual before using the device. The operator must be familiar with the manual and follow the instructions carefully.
- This use and maintenance manual is *subject to change due to technical improvements - the manufacturer assumes no responsibility for any mistakes or misprints.*



Respect your environment: think before printing the full manual on paper.

1.2 Danger levels and other symbols



The magnets in the back of the instrument can damage credit cards, hard driver, mechanical watches, pacemakers, defibrillators and other devices proven sensitive to magnetic fields. It is recommended to keep the instrument at a distance of at least 25cm away from these devices.

Symbol	Meaning	Comments
	WARNING	Read information carefully and prepare safety appropriate action! To prevent any danger from personnel or other goods. Disobey of this manual may cause danger to personnel, the plant or the environment and may lead to liability loss.
	Information on LCD	
	Ensure correct disposal	Dispose of the battery pack at the end of its working life only at the dedicated collecting bin. The customer takes care, on his own costs, that at the end of its working life the product is collected separately and it gets correctly recycled.
	Keyboard with preformed keys with main control functions.	

2.1 Intended purpose

This chapter describes the areas of application for which the S6000 is intended.

Using the S6000 in other application areas is on the risk of the operator and the manufacturer assumes no responsibility and liability for loss, damage or costs which could be a result. It is mandatory to read and pay attention to the operating/maintenance manual.

All products of the series S6000 are handheld measuring devices in professional flue gas analysis for:

- Small furnaces (burning oil, gas, wood, coal)
- Low-temperature and condensing boilers
- Gas heaters

Due to other configuration with electrochemical cells it is possible to use the measuring instrument in following application area:

- Service engineers/mechanics of burner/boiler manufacturers
- Service industrial combustion plants

Additional functions of the measuring instrument:

- Flue gas analysis according 1. BImSchV or qA-mean value (selectable)
- Calculating of stack heat loss and efficiency
- CO- and NO environment measurement
- Store Smoke value, calculating mean value
- Measuring differential pressure
- Draft measurement

2.2 Improper use of the product

The use of S6000 in application areas other than those specified in [Section 2.1 "Intended use of the product"](#) is to be considered at the operator's risk and the manufacturer assumes no responsibility for the loss damage or costs that may result. It is compulsory to read and pay attention to the instructions in this use and maintenance manual.

S6000 should not be used:

- For continuous measurements > 1h
- As safety alarm instrument

3.0 WORKING PRINCIPLE

3.1 General overview of the Analyzer

S6000 is a portable analyzer for flue gas and emissions.

The instrument is equipped with:

- Pneumatic circuit which can accommodate up to 6 sensors in the FLEX-sensors series.
- Intuitive user interface: the instrument can be used without the support of the user manual.
- Wide (2.2"x3.7") and bright TFT color display which delivers great readability thanks to the zoom function and an efficient backlight.
- Single rechargeable 'Li-Ion' battery pack, used to power both the unit and the thermal printer.
- Thermal printer integrated in the instrument.
- Connectivity with a computer through the USB connection and/or Bluetooth ®. Once the special software provided with the instrument is used, this allows for the storage of combustion analysis as well as the configuration of the main parameters.
- Connectivity with a smartphone through Bluetooth®. Once the specific APP Seitron Smart Analysis available on Google play-store is installed on the device, the user can start remote analysis of combustion and/or view real-time data of the analysis in progress.

Main functions:

- Combustion analysis in manual or automatic mode.
- Comes with 15 most used fuel parameters (such as natural gas, LPG, gas oil and fuel oil).
- Possibility to store in memory the parameters for 32 further fuels, once their chemical composition is known.
- Monitoring of pollutants (emissions).
- Memory capable of storing up to 2,000 full analysis.
- Storing of acquired data and their averaging.

Measurable gases:

- CO, CO₂, CxHy referred to the methane
- O₂
- CO (ambient monitoring)
- CO / H₂
- CO (low, medium, high)
- NO (low, medium)
- NO₂ (low, medium)
- SO₂ (low, medium)
- NOx
- H₂S
- NH₃
- H₂

Measurements:

- Ambient CO (with the internal sensor)
- Stack draft.
- Smoke (with the use of the external manual pump).
- Gas pressure in the piping, pressure in the burning chamber and check of the pressure switches, using the measurement range up to 200hPa.
- Combustion air measurement.
- Auxiliary temperatures.
- Air speed for air or flue gas leaving the stack with the use of Pitot tube
- Ionization current measurement (with external auxiliary probe)

Maintenance:

- Sensors can be replaced by the user without having to ship the instrument to the service center, because the spare sensors delivered are pre-calibrated.
- The instrument requires annual calibration, to be carried out at any authorized service center.

Certificate of calibration

The instrument is accompanied with a calibration certificate compliant with standard EN 17025.



4.1 Working principle

The gas sample is taken in through the gas probe, by a diaphragm suction pump inside the instrument. The measuring probe has a sliding positioning cone that allows the probe to be inserted in holes with a diameter of 11 mm (0.43") to 16 mm (0.65") and to adjust the immersion depth. It is recommended to have the **gas sampling point roughly in the center of the flue/stack**.

The gas sample is cleaned of humidity and impurities by a condensate trap and filter positioned along the rubber hose that connects the probe to the analyzer. The gas is then analyzed in its components by electrochemical and infrared sensors. The electrochemical cell guarantees high precision results in a time interval of up to about 60 minutes during which the instrument can be considered very stable. When measurement is going to take a long time, we suggest auto-zeroing the instrument again and flushing the inside of the pneumatic circuit for three minutes with clean air. During the zero calibrating phase, the instrument aspirates clean air from the environment and detects the cells' drifts from zero (20.95% for the O₂ cell), then compares them with the programmed values and compensates them. The pressure sensor autozero must, in all cases, be done manually prior to measuring pressure. The values measured and calculated by the microprocessor are viewed on the LCD display which is backlit to ensure easy reading even when lighting is poor.

4.2 Measurement cells

The instrument takes advantage of pre-calibrated FLEX-series gas sensors for the measurement of Oxygen (O₂), Carbon Monoxide (CO - Hydrogen compensated measurement, Nitrogen Oxide (NO), Nitrogen Dioxide (NO₂), Sulphur Dioxide (SO₂) and hydrogen sulphide (H₂S). The sensors do not need particular maintenance yet they have to be replaced periodically when exhausted. Measurement of the oxygen (%O₂) is carried out with an electrochemical cell that loses sensitivity over time because it is constantly exposed to 20.9% Oxygen in ambient air. The toxic gases (CO, SO₂, NO, NO₂) are measured with electrochemical sensors that are not subject to natural deterioration being intrinsically lacking of oxidation processes. The measurement cells are electrochemical cells made up of an anode, a cathode, and an electrolytic solution, which depends on the type of gas to be analyzed. The gas penetrates the cell through a selective diffusion membrane and generates an electric current proportional to the absorbed gas. Such current is measured, digitalized, temperature-compensated, processed by the microprocessor, and displayed. The gas shall not be at such a pressure to damage or destroy the sensors; for this reason the suction pump is continuously adjusted, in order to ensure an appropriate flow to the sensors. The maximum estimated allowed pressure is $\pm 100\text{hPa}$ gage.

The response times of the measurement cells used in the analyzer are:

O ₂	=	20 sec. at 90% of the measured value
CO(H ₂)	=	50 sec. at 90% of the measured value
CO	=	50 sec. at 90% of the measured value
NO	=	40 sec. at 90% of the measured value
NO ₂	=	50 sec. at 90% of the measured value
SO ₂	=	50 sec. at 90% of the measured value
H ₂ S	=	50 sec. at 90% of the measured value
NH ₃	=	90 sec. at 90% of the measured value
H ₂	=	90 sec. at 90% of the measured value

It is therefore suggested to wait 5 minutes (anyway not less than 3 minutes) in order to get reliable analysis data.

If sensors of poison gases are submitted to concentrations higher than 50% of their measurement range for more than 10 minutes continuously, they can show up to $\pm 2\%$ drift as well as a longer time to return to zero. In this case, before turning off the analyzer, it is advisable to wait for the measured value be lower than 20ppm by in taking clean air. If there is an automatic calibration solenoid, the device performs an automatic cleaning cycle and it turns off when the sensors return to a value close to zero. The auto-zero solenoid valve allows the operator to turn the instrument on with the probe inserted in the flue. Up to 4 alarm set points are programmable with visual and acoustic signals for the relevant measurement parameters. The standard provides that the instrument must be calibrated by a certified laboratory that is authorized to issue annual calibration certificates. Exhausted cells can be easily replaced by the user without depriving himself of the instrument and without complicated calibration procedures with certified mixtures as they are pre-calibrated before being supplied.

Seitron Americas certifies the accuracy of the measurements only upon a calibration certificate issued by its laboratory or other approved laboratory.



WARNING

Some sensors (for example NH₃, H₂, H₂S, SO₂,...) are sensible to other gases called interfering gases.

On the analysis phase, the influence of interfering gases is compensated only if on the instrument are installed the correspondent sensors.

If a sensor sensitive to NO and NO₂ interfering gases is installed on the instrument, but only the NO sensor is installed in the instrument, NO₂ gas compensation is carried out starting from the NOx/NO ratio.

4.3 CO dilution

One of the characteristics of the electrochemical sensor for the measurement of CO is the need to require very long self-calibration time in case it has been in contact with high gas concentration (greater than the full scale) for a long time. The CO sensor is therefore protected in this instrument by an automatic dilution system that allows to extend the measuring range of the sensor without overloading the sensor itself.

The dilution system allows to have the CO sensor efficient any time and ready to perform properly even in case of very high concentration of CO.

The dilution system also allows to extend the measurement range of the CO sensor as follows:

- up to 100,000 ppm for a CO sensor with 8000 ppm full scale
- up to 250,000 ppm for a CO sensor with 20,000 ppm full scale

In this way in addition to better manage the wearing of the sensor, it is also possible to continue sampling, without any work interruption.

4.4 Fuel types

The device is provided with the technical data of the most common types of fuels stored in its memory. By using the PC configuration program, available as an option, it is possible to add fuels and their coefficients in order to define up to a maximum of 32 combustibles, other than the default ones.

For more details see [Annex C](#).

4.5 Pressure sensor, piezoelectric, temperature compensated

The instrument is internally provided with a piezoresistive differential pressure sensor, temperature compensated, for measuring pressure or draft.

This sensor is differential type thus, thanks to the second measurement port, can be used for measuring the draft (depressurization) in the stack, for the leak test of the pipes, for differential pressure measurement, for measuring the velocity of the flue gas using a Pitot tube, for flow measurement, and possibly for other measurements (pressure of gas in the piping, pressure loss across a filter, etc.).

The measurement range is -10,00 hPa .. +200,00 hPa.

Any potential drift of the sensor are nulled thanks to the autozeroing system which in this instrument can NOT be operated with the flue gas probe inserted in the stack.



WARNING

ANY PRESSURE APPLIED TO THE SENSOR GREATER THAN ± 300 hPa MAY CAUSE A PERMANENT DEFORMATION OF THE MEMBRANE, THUS DAMAGING IRREVERSIBLY THE SENSOR ITSELF.

4.6 Gas extraction pump

The sample pump located inside the instrument is a DC-motor-driven diaphragm pump, powered by the instrument, and is such as to obtain optimal flow of the sampled gas being analysed; an internal sensor that measures the flow allows to:

- Keep the flow rate of the pump constant
- Check the efficiency of the pump
- Check the degree of clogging of the filters

4.7 Simultaneous measurement of pressures, O₂, pollutants

The instrument, to obtain perfect boiler combustion parameters, allows to measure simultaneously the input and output pressure of the gas valve, the level of O₂, the levels of pollutants and all the calculated parameters needed to obtain the correct value of yield.

[See section 14.1.3.](#)

4.8 Smoke measurements

It is possible to enter the smoke values measured according to the Bacharach scale. The instrument will calculate the average and print the results in the analysis report.

An external pump, available as an option, must be used to perform this measurement.

4.9 Temperature measurements

S6000 can measure several types of temperatures taking advantage of dedicated probes.

4.10 Auxiliary measurements

This analyzer also features a connection to optional external sensors for draft measurement as well as for the measurement of the ionization current in the boilers.

4.11 Bluetooth® connection

The S6000 analyzer is internally equipped with a Bluetooth® module, which allows the communication with the following remote devices:



- Remote Bluetooth® printer
- Smartphone or tablet with installed the OS Google Android v.4.1 (Jelly Bean) or later and the proper APP 'Seitron Smart Analysis' (available on Google Play Store) installed.
- PCs running Microsoft Windows 7 or later and Bluetooth® interface upon installation of the specific software 'Seitron Smart Analysis' supplied together with the instrument.

The maximum transmission range in open field is 100 meters (Class 1 Bluetooth® module), provided that also the communication companion is equipped with a Class1 Bluetooth® interface.

This solution allows greater freedom of movement for the operator who is no longer bound directly to the instrument for acquisition and analysis, with significant advantages for many applications.

5.0 DESCRIPTION OF COMPONENTS

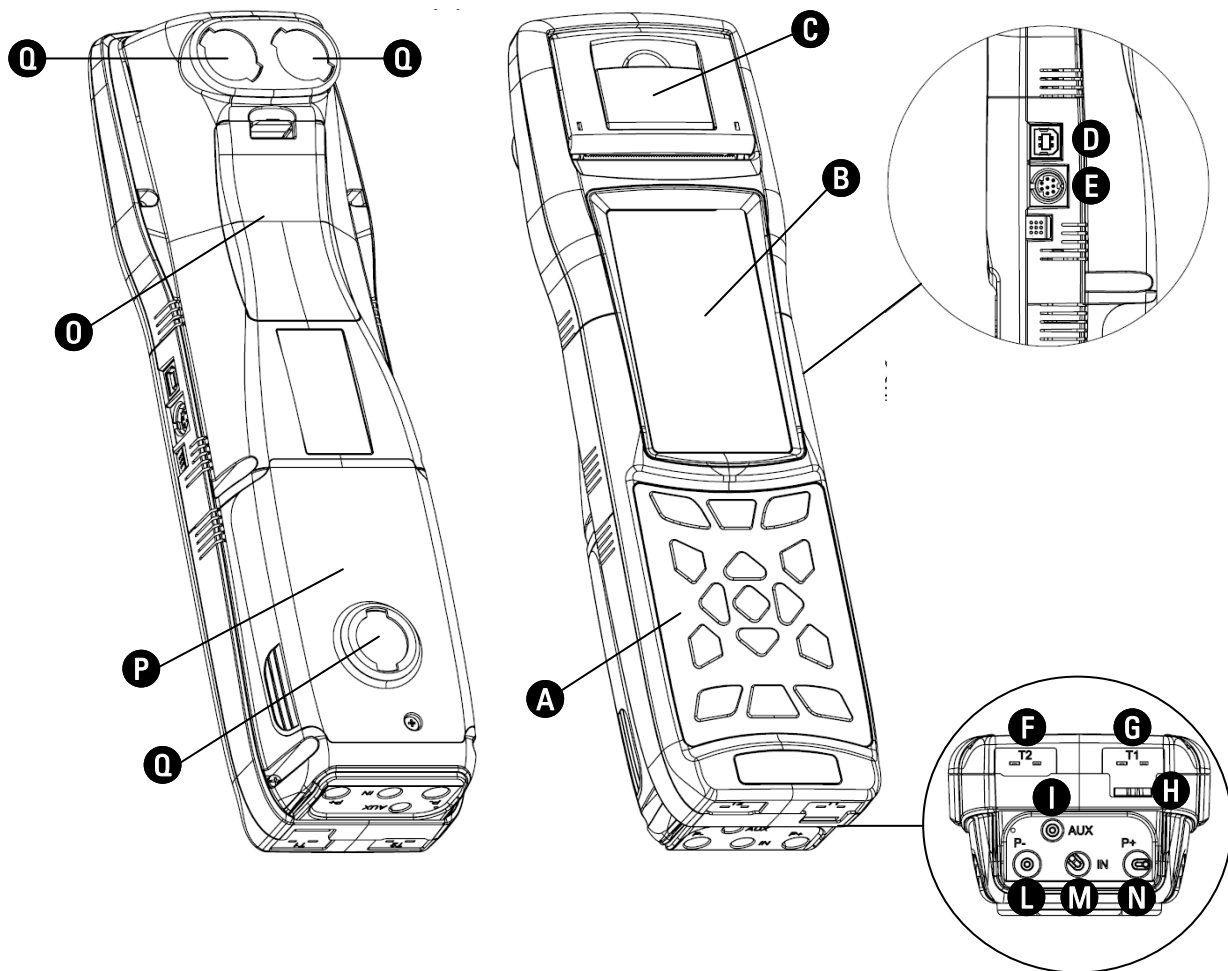

LEGEND:

A keypad
Adhesive polyester keypad with preformed keys featuring main control functions.

KEYS	FUNCTION
	Activates the context keys shown on the display
	Access to the Memory menu
	Access to the Printing menu
	Access to the Configuration menu
	Performs the analysis of the combustion
	Access to the Measurements menu

KEYS	FUNCTION
	Turns the device On / Off
	Exits the current screen
	Select and/or Modify
	Confirm settings
	Backlight turn-off.



B Display

TFT 272 x 480 pixel backlit color display with 21 characters available and 8 lines. Allows the user to view the measured parameters in the most comfortable format; a Zoom function displays the measured values in magnified form.

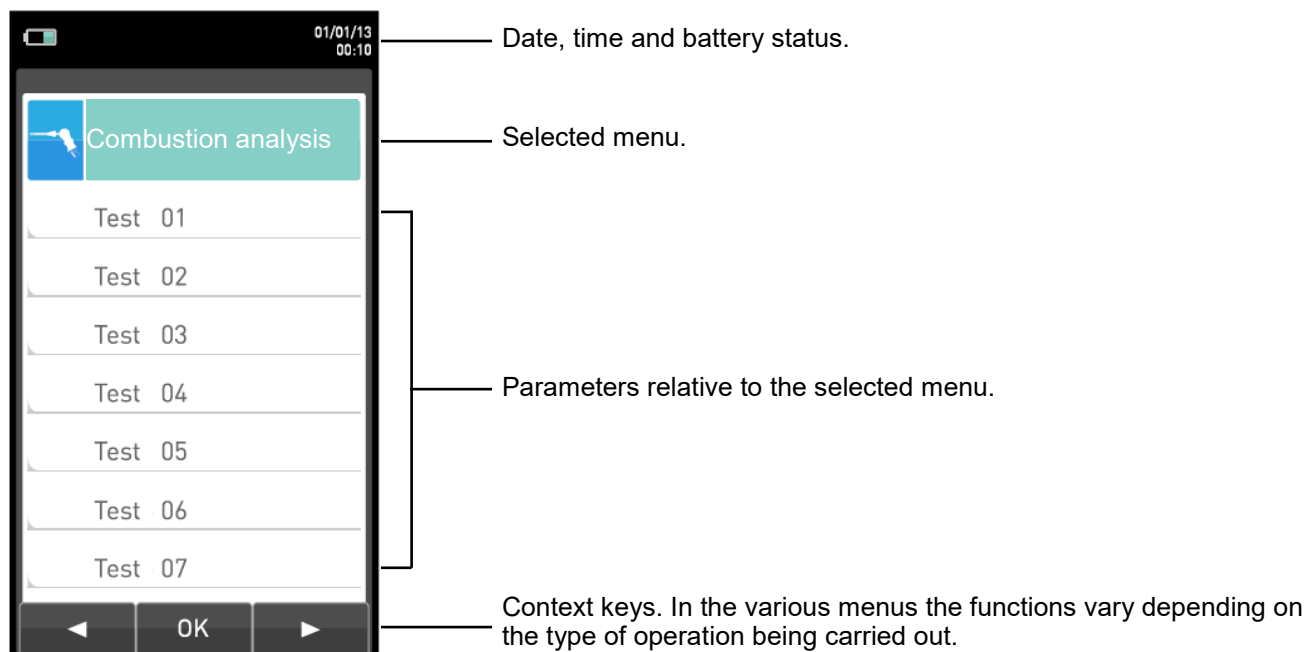
CAUTION: If the instrument is exposed to extremely high or extremely low temperatures, the quality of the display may be temporarily impaired. Display appearance may be improved by acting on the contrast key.



Backlight

The backlight can be turned off with the simultaneous pressure on keys  + .

The backlight is turned on when any key is pressed, except '  ' key.

C Printer

The thermal printer can print on either non-fading polyester paper or regular thermal paper. Thermal polyester cannot be altered and it is resistant to light, to temperature, to humidity and to water.

The print menu is accessed by pressing the relative key and, besides enabling read-out printing, the menu also allows you to modify print settings and to advance the paper manually so as to facilitate paper roll replacement.

D USB connector (type B)

Used to connect the instrument to a personal computer running Microsoft Windows 7 or later upon installation of the specific software 'Seitron Smart Analysis', supplied with the instrument.

E Connector for the connection of auxiliary probes.

Serial connector, Mini Din 8-pin, for connection of an external probe such as:

- Probe for measurement of the ionization current
- Micromanometer

- F 'T2' Connector**
Used to connect the Tc-K plug of the combustion air temperature probe.
- G 'T1' Connector**
Used to connect the Tc-K male connector of the gas temperature probe.
- H Gas outlet**
- I 'AUX' Connector**
Input for optional external probes.
- L 'P-' Pneumatic connector**
negative input (P-).
- M Pneumatic connector 'IN'**
input for the connection of the branch of the gas sampling probe with the condensation separating and anti-dust filter assembly.
- N 'P+' pneumatic connector**
Draft measurement positive input (P+).



Inputs 'P+' and 'P-' are respectively the positive and negative inputs of the internal differential pressure sensor, piezoresistive, temperature compensated; therefore these can be simultaneously used to measure the differential pressure.

- O Cover to access battery compartment.**
- P Cover to access cell compartment.**
- Q Magnets.**
- R Instrument data label.**

6.0 MAIN CONFIGURATIONS

	S6000-5DS	S6000-5SC	S6000-5SH	S6000-6DSC	S6000-6DSH	S6000-5DC
O2 SENSOR	✓	✓	✓	✓	✓	✓
CO+H2 SENSOR		✓	✓	✓	✓	✓
CO+H2 SENSOR low range	✓					
NO SENSOR		✓	✓			✓
NO SENSOR low range	✓			✓	✓	
NO2 SENSOR						✓
NO2 SENSOR low range	✓			✓	✓	
SO2 SENSOR		✓	✓			
SO2 SENSOR low range	✓			✓	✓	
CxHy SENSOR		✓		✓		✓
H2S SENSOR 500 ppm			✓		✓	
EXPANDABLE TO 6 SENSORS	✓	✓	✓	✓	✓	✓
CO DILUTION	✓	✓	✓	✓	✓	✓
BLUETOOTH	✓	✓	✓	✓	✓	✓
CALIBRATION CERTIFICATE	✓	✓	✓	✓	✓	✓
QUICK GUIDE	✓	✓	✓	✓	✓	✓
GAS SAMPLE PROBE 300mm	✓	✓	✓	✓	✓	✓
CONDENSATE TRAP	✓	✓	✓	✓	✓	✓
DIFFERENTIAL PRESSURE MEASUREMENT KIT	✓	✓	✓	✓	✓	✓
BATTERY CHARGER	✓	✓	✓	✓	✓	✓
US PLUG FOR BATTERY CHARGER	✓	✓	✓	✓	✓	✓
ADAPTER CABLE USB type A / USB type B	✓	✓	✓	✓	✓	✓
PC SOFTWARE	✓	✓	✓	✓	✓	✓
HARD CASE	✓	✓	✓	✓	✓	✓
ROLL OF PAPER PRINTER	✓	✓	✓	✓	✓	✓

7.0 TECHNICAL SPECIFICATIONS

7.1 Technical features

Power supply:	Li-Ion battery pack with internal protection circuit, rechargeable.
Battery charger:	External 5Vdc 2A battery charger with female A-type USB connector + connection to the device with the same serial communication cable supplied.
Charging time:	5 hours to charge from 0% to 90% (6 hours for 100%). The device can also be charged by connecting it to the PC, the device must be turned off, the charging time depends on the output current from the PC and may be more than 12 hours.
Instrument working time:	12 hours of non-stop operation (excluding printing).
Display:	4.3" TFT 272x480 pixels graphic color with backlight
Connectivity:	
Communication port:	USB connector type B.
Bluetooth®:	Class 1. Communication distance <100 meters (in open field)
Autozero:	Automatic autozero cycle with the probe not inserted in the stack.
Dilution:	Widens the CO sensor measurement range up to 100.000ppm (10.00%). Programmable as simple protection of the CO sensor with the intervention level set by the user. Pre-set triggering threshold at 1500 ppm.
Gas measurement sensors:	Up to 6 configurable sensors: electrochemical, NDIR (single cell) and pellistor.
Programmed fuels:	15 factory pre-set plus 32 user-programmable.
Self-diagnosis:	All the functions and internal functions are checked and anomalies signaled.
Temperature measurement:	Double K thermocouple input with mini connector (ASTM E 1684-96) to measure differential temperature (supply and return).
Measurement of ambient temp.:	Via internal sensor or T2 thermocouple input with remote probe.
Printer:	Thermal integrated with easy loading paper and sensor for the presence of paper.
Printer powered:	By the analyzer batteries.
Printer autonomy:	Up to 40 analysis reports with the batteries fully charged.
Internal data memory:	2000 complete data analyses, time and name of the customer can be stored.
User data:	8 programmable user names.
Print header:	6 lines x 24 characters user-customized.
Suction pump:	0.3 US gallon/min heads at the flue up to 135mbar.
Measurement of flow:	Internal sensor to measure the flow of the pump.
Condensate trap:	Outside the instrument.
Line filter:	With replaceable cartridge, 99% efficient with 20um particles (inside the condensate trap).
Smoke:	Using an external hand pump; it is possible to enter and print the smoke index.
Leak test:	Gas pipes tested for leaks with separate printout of the result, by means of the attachment AACKT02 with automatic calculation of pipe volume.
Condensing boiler efficiency:	Automatic recognition of the condensing boiler, with calculation and printout of efficiency (>100%) on the LHV (Lower Heating Value) Environmental gases: Measurement and separate printout of the ambient CO values.
Draft test:	By using the internal sensor connected to the port P-, resolution 0,1 Pa, accuracy 0,5 Pa. Draft test must be carried out only by means of the AACDP02 external accessory.
Operating temperature:	23°F to 113° F (-5 °C to +45 °C)
Storage temperature:	-4°F to 122°F (-20 °C to +50 °C)
Humidity limit:	20% .. 80% RH
IP rating:	IP42
Air pressure:	Atmospheric

Outer dimensions:
Weight:

Analyzer Only : 3.5 x 12.2 x 2.4" (9 x 31 x 6 cm) (H x W x D)
Analyzer Only : ~2 lbs. (~ 1 Kg)

7.2 Measurement and Accuracy Ranges

MEASUREMENT	SENSOR	RANGE	RESOLUTION	ACCURACY	
O ₂	Electrochemical sensor	0 .. 25.0% vol	0.1% vol	±0.2% vol	
CO with H ₂ compensation	Electrochemical sensor	0 .. 8000 ppm	1 ppm	±10 ppm	0 .. 200 ppm
				±5% measured value	201 .. 2000 ppm
diluted	Electrochemical sensor	10.00% vol	0.01% vol	±10% measured value	2001 .. 8000 ppm
CO Low range with H ₂ compensation	Electrochemical sensor	0 .. 1000.0 ppm	0.1 ppm	±2 ppm	0 .. 40.0 ppm
				±5% measured value	40.1 .. 1000.0 ppm
diluted	Electrochemical sensor	100000 ppm	10 ppm	±20% measured value	
CO Mid range	Electrochemical sensor	0 .. 20000 ppm	1 ppm	±100 ppm	0 .. 2000 ppm
				±5% measured value	2001 .. 4000 ppm
diluted	Electrochemical sensor	25% vol	0.01% vol	±10% measured value	4001 .. 20000 ppm
CO Hi range	Electrochemical sensor	0 .. 10.00% vol	0.01% vol	±0.1% vol	0 .. 2.00 %
				±5% measured value	2.01 .. 10.00 %
NO	Electrochemical sensor	0 .. 5000 ppm	1 ppm	±5 ppm	0 .. 100 ppm
NO Low range	Electrochemical sensor	0 .. 500 ppm	0.1 ppm	±5% measured value	101 .. 5000 ppm
				±2 ppm	0 .. 40.0 ppm
				±5% measured value	40.1 .. 500.0 ppm
NO _x	Calculated				
SO ₂	Electrochemical sensor	0 .. 5000 ppm	1 ppm	±5 ppm	0 .. 100 ppm
				±5% measured value	101 .. 5000 ppm
SO ₂ (J57-2017)	Electrochemical sensor	0 .. 1000 ppm	0,1 ppm	±2 ppm	0 .. 40 ppm
			1 ppm	±5% measured value	41 .. 1000 ppm
SO ₂ Low range	Electrochemical sensor	0 .. 500 ppm	0.1 ppm	±2 ppm	0 .. 40.0 ppm
				±5% measured value	40.1 .. 500.0 ppm
NO ₂	Electrochemical sensor	0 .. 1000 ppm	1 ppm	±5 ppm	0 .. 100 ppm
				±5% measured value	101 .. 1000 ppm
NO ₂ Low range	Electrochemical sensor	0 .. 500 ppm	0.1 ppm	±2 ppm	0 .. 40.0 ppm
				±5% measured value	40.1 .. 500.0 ppm
C _x H _y	Pellistor sensor	0 .. 5.00% vol	0.01% vol	±0.25% vol	
CO ₂	Calculated	0 .. 99.9% vol	0.1% vol		
CO ₂	NDIR sensor	0 .. 20.0% vol	0.1% vol	±0.3% vol	0.00 .. 6.00 %
				±5% measured value	6.01 .. 20.0 %
CO ₂	NDIR sensor	0 .. 50.0% vol	0.1%	±1% vol	0.00 .. 10.00 %
				±2% vol	10.01 .. 50.0 %
H ₂ S	Electrochemical sensor	0 .. 500 ppm	0.1 ppm	±5 ppm	0 .. 100.0 ppm
				±5% measured value	100.1 .. 500.0 ppm
NH ₃	Electrochemical sensor	0 .. 500 ppm	0.1 ppm	±10 ppm	0 .. 100.0 ppm
				±10% measured value	100.1 .. 500.0 ppm
H ₂	Electrochemical sensor	0 .. 2000 ppm	1 ppm	±10 ppm	0 .. 100.0 ppm
				±10% measured value	100 .. 2000.0 ppm
PI* (CO/CO ₂ ratio)	Calculated		0.01%		
Air temperature	TcK sensor	-20.0 .. 1250.0 °C	0.1 °C	±0.5 °C	0 .. 100 °C
				±0.5% measured value	101 .. 1250 °C
Flue gas temperature	TcK sensor	-20.0 .. 1250.0 °C	0.1 °C	±0.5 °C	0 .. 100 °C
				±0.5% measured value	101 .. 1250 °C
Pressure (draft & differential)	Piezoelectric sensor	-10.00 .. +200.00 hPa	0.01 hPa	±1% measured value	-10.00 .. -2.01 hPa
				±0.02 hPa	-2.00 .. +2.00 hPa
				±1% measured value	+2.01 .. +200.00 hPa
Differential temperature	Calculated	0 .. 1250.0 °C	0.1 °C		
Air index	Calculated	0.00 .. 9.50	0.01		
Excess air	Calculated	0 .. 850 %	1 %		
Stack loss	Calculated	0.0 .. 100.0 %	0.1 %		
Efficiency	Calculated	0.0 .. 100.0 %	0.1 %		
Efficiency (condensing)	Calculated	0.0 .. 120.0 %	0.1 %		
Smoke index	External instrument	0 .. 9			

* The Poison Index ratio (P.I.) is a reliable indicator of a boiler or burner good operation. It only takes a simple flue gas test to determine whether or not a service is needed to fix the system.

8.1 Preliminary operations

Remove the instrument from its packing and check it for damage. Make sure that the content corresponds to the items ordered. If signs of tampering or damage are noticed, notify the Seitron Americas service center or distributor immediately and keep the original packing. A label at the rear of the analyzer bears the serial number. This serial number should always be stated when requesting technical assistance, spare parts or clarification on the product or its use.

Seitron Americas maintains an updated database for each and every instrument. Before using for the first time we recommend you charge the batteries completely.

8.2 WARNING

- Use the instrument with an ambient temperature between 23 and 113 °F (-5 and +45°C).

IF THE INSTRUMENT HAS BEEN KEPT AT VERY LOW TEMPERATURES (BELOW OPERATING TEMPERATURES) WE SUGGEST WAITING A WHILE (1 HOUR) BEFORE SWITCHING IT ON TO HELP THE SYSTEM'S THERMAL BALANCE AND TO PREVENT CONDENSATE FORMING IN THE PNEUMATIC CIRCUIT.

- When it has finished being used, before turning the instrument off remove the probe and let it aspirate ambient clean air for at least 5 minutes to purge the pneumatic path from all traces of gas.
- Do not use the instrument if the filters are clogged or damp.
- Before putting the measuring probe back in its case after use, make sure it has cooled down enough and there is no condensate in the tube. It might be necessary to periodically disconnect the filter and the condensate separator and blow compressed air inside the tube to eliminate all residues.
- Remember to have the instrument checked and calibrated once a year in order to comply with the existing standards.

IF ENABLED BY FACTORY OR THE ASSISTANCE CENTER, FROM 30 DAYS PRIOR TO THE CALIBRATION TO EXPIRE, THE DISPLAY WILL SHOW A MESSAGE TO REMIND THE USER THAT THE INSTRUMENT HAS TO BE SENT TO THE ASSISTANCE CENTER.

Example:

Press and hold for a few seconds

CONTEXT KEY	FUNCTION
F1	Displays the information about the assistance center.
F2	Ignores temporarily the message. Next time the instrument will be turned on, the remainder will be displayed again.
F3	Ignores permanently the message.

8.3 Analyzer power supply

The instrument contains a high-capacity Li-Ion rechargeable battery. The battery feeds the instrument, built-in printer and any other probes or remote devices that may be connected. The instrument runs for approximately 18 hours if the printer is not used. Should the battery be too low to effect the necessary measurements, the instrument can be hooked up to the mains via the power pack provided, allowing operations (and analysis) to proceed. The battery will be recharged whilst the instrument is being used. The battery charging cycle takes up to 3 hours for a complete charge and finishes automatically.

WARNING: If the instrument is not going to be used for a long time (e.g. summer) it is advised to store it after a complete charging cycle; furthermore, perform a complete charging cycle once every 4 months.

8.3.1 Checking and replacing the batteries

The state of the internal battery can be displayed during the auto-calibration of the device and possibly later via the information menu.

In the menu, the remaining battery power is displayed.

If battery charge appears to be low, let it discharge completely and then carry out a full 100% charge cycle by connecting the instrument to the power pack for 3 hours.

If the problem persists, replace the battery pack with a Seitron Americas original or contact the SERVICE CENTER to carry out the necessary repairs.

The average life of the battery pack is 500 charging/discharging cycles. To exploit this characteristic to the full it is advisable to always use the instrument powered by the internal batteries and to charge it only when it gives the battery flat message.

	<p>THE INSTRUMENT IS SHIPPED WITH A BATTERY LEVEL LOWER THAN 30% AS REQUIRED BY CURRENT AIR TRANSPORTATION STANDARDS. BEFORE USE PERFORM A COMPLETE CHARGING CYCLE OF 8 HOURS.</p> <p>IT IS ADVISABLE TO CHARGE THE BATTERY AT AN AMBIENT TEMPERATURE RANGING BETWEEN 50°F AND 86°F.</p>
---	--

The instrument can be left in stock for a period of time depending on the charging level of the battery; below there is a table showing the correlation between stock time and charging level.



BATTERY LEVEL	STOCK TIME
100%	110 days
75%	80 days
50%	45 days
25%	30 days

8.3.2 Use with external power pack

The instrument can work with the batteries fully discharged by connecting the external power pack provided.



	<p>THE POWER SUPPLY/BATTERY CHARGER IS A SWITCHING TYPE ONE.</p> <p>THE APPLICABLE INPUT VOLTAGE RANGES BETWEEN 90Vac AND 264Vac.</p> <p>INPUT FREQUENCY: 50-60Hz.</p> <p>THE LOW VOLTAGE OUTPUT IS 5 VOLT WITH AN OUTPUT CURRENT GREATER THAN 1.5A.</p> <p>LOW VOLTAGE POWER CONNECTOR: A-TYPE USB CONNECTOR + CONNECTION CABLE WITH B-TYPE PLUG.</p>
---	---

8.4 QR code generation

By pushing at the same time the buttons  +  , the instrument generates and shows on the display a QR code to download the data of the performed measures, after installing the App “Seitron Smart Analysis” downloadable from the AppStore or Google Play Store.

Minimum requirements for installing the App “Seitron Smart Analysis”

Operative systems: Android from version 4.1
 Apple (iOS)

	<p>THE INSTRUMENT GENERATES THE QR CODE ONLY WHEN THE INTERACTIVE FUNCTION “” IS DISPLAYED ON SCREEN.</p>
---	---

8.5 Connection diagram

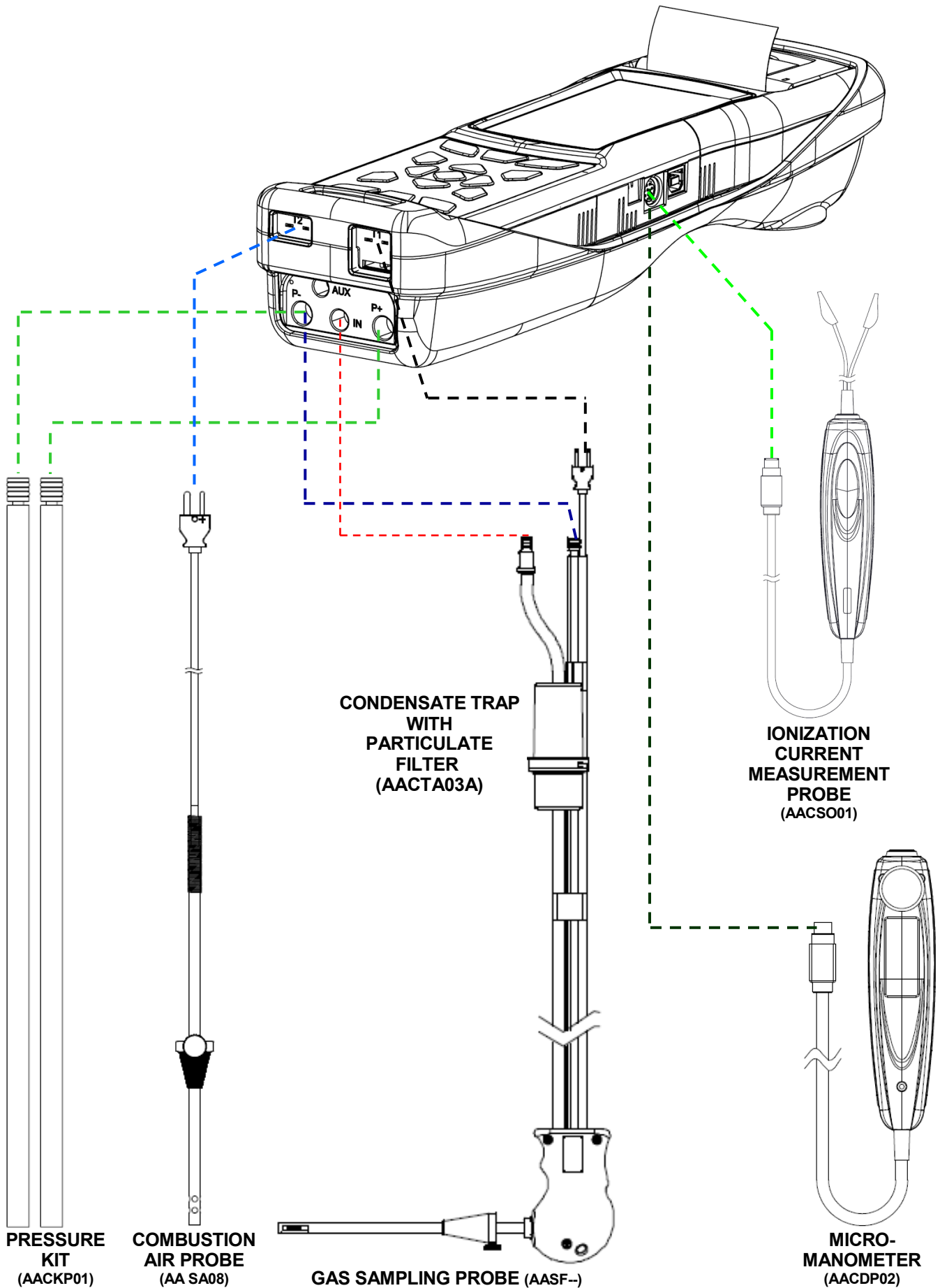

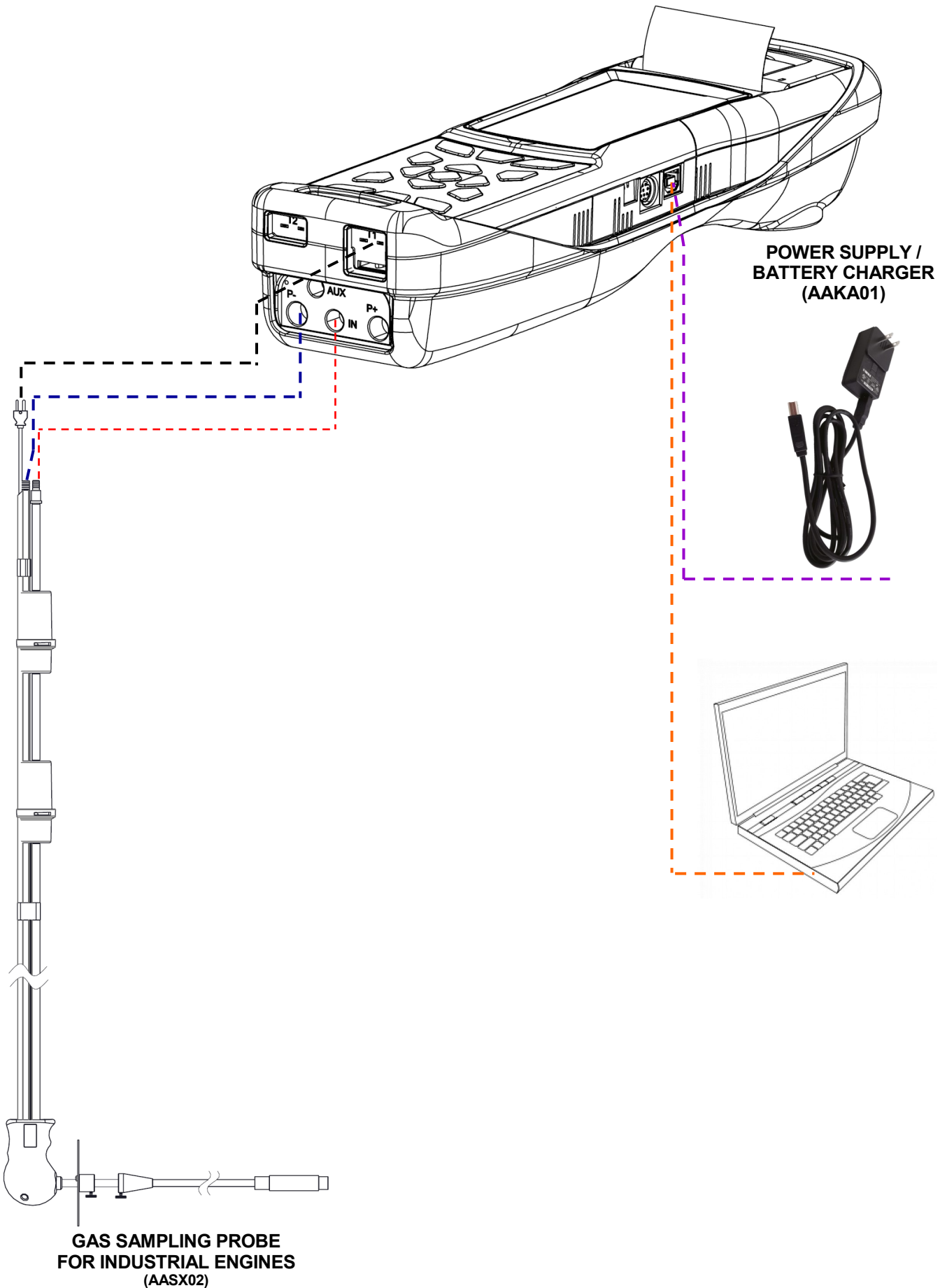

8.5.1 Gas sampling probe

General description

The gas sampling probe is made of a stainless steel hose, with a plastic hand grip and includes an internal K-type thermocouple (Ni-NiCr) for measuring the gas temperature of the gas.

The thermocouple is located in the probe tip. It is connected to the instrument via a compensated cable running in a specific slot of the rubber hose of the sample probe. The compensation of the cold junction is performed with a Pt100 RTD (Resistance Temperature Detector) that measures the temperature in correspondence of the thermocouple connector.

The K-type thermocouple (Ni-NiCr) allows continuous measurements at high temperatures.

The instrument has another internal Pt100 RTD for measuring the internal temperature; this sensor is also used for measuring the ambient temperature.

In case you wish to detect the temperature of the combustion air directly into the intake stack you will have to use the Tc-K type optional remote sensor. It is suggested to perform this measurement to carry out the calculation of the efficiency of the system when the temperature of the combustion air is different than the temperature of the environment where the instrument is positioned.

Technical features:

Temperature sensor:		K-type thermocouple (Ni-NiCr) - IEC584 - class 1
Pneumatic connectors:	Pressure:	Male - diameter 3.5"
	Gas input:	Male - diameter 0.31"
Connettore sensore temperatura:		TC-K mignon
Tube:	Material:	EPDM
Adaptor for pockets:	Material:	Galvanized steel
	External diameter:	0.39 .. 0.87"
Handle:	Material:	Nylon
	Color:	Black
Tip:	Material:	AISI 304 stainless steel
	Diameter:	0.31"

CODE	TIP LENGTH	EPDM TUBE LENGTH	MAXIMUM WORKING TEMPERATURE
AASF51A	180 mm // 7 inches	2 m // 6.6 ft	752°F - immersion depth 4"
AASF52A	300 mm // 12 inches	3 m // 10 ft	1112°F - immersion depth 6.3"
AASF62A	300 mm // 12 inches	3 m // 10 ft	1112°F - immersion depth 6.3"
AASF65A	750 mm // 30 inches	3 m // 10 ft	1472°F - immersion depth 19.6"
AASF66A	1000 mm // 39.3 inches	3 m // 10 ft	2192°F - immersion depth 19.6"
AASL05A	300 mm // 12 inches	2 m // 6.6 ft	266°F - immersion depth 6.3"

WARNING: in case of measurement of very high temperatures it is recommended to remove the tip slowly in order to let it cool down without suffering heat stress; once extracted from the measurement point do not place it on a cold surface, otherwise this could affect the internal temperature sensor; in case of failure of the thermocouple it is possible to replace the bare element with a compensated cable ([see section 18 "Spare parts and servicing"](#)).

8.5.2 Smoke sampling probe for average CO measurement

This probe, is made up by an INOX AISI 304 steel multi-perforated stiff tip, provided with a adjustable well adapter, it allows to take the smoke from different spots of the stack, so to obtain the average CO measure.

The smoke temperature is measured through a thermocouple type K (Ni-NiCr) inserted in the probe tip. This is connected to the instrument through a compensated cable inserted in a proper seat of the smoke sampling probe rubber pipe. Because of the technical construction of the tip, the internal thermocouple does not detect immediately the correct smoke temperature. The compensation of the cold junction is made with a Pt100 thermoresistance which detect the temperature in correspondence of the thermocouple connector. The thermocouple type K (Ni-NiCr) allows continuous measures at high temperatures. This probe can be also used for the combustion analysis.

Technical specifications

Temperature sensor:		Thermocouple type K (Ni-NiCr) - IEC584 - class 1
Pneumatic connectors:		Male- diameter 0.35" pressure connection
		Male - diameter 0.31" gas entrance connection
Temperature sensor connector:		TC-K mignon
Tube:	Material:	EPDM



Well adapter:	Length:	6.6 ft
	Material:	Galvanized steel
	External diameter:	0.4" .. 0.9"
Handle:	Material:	Nylon
	Color:	Black
Tip:	Material:	Stainless steel AISI 304
	Diameter:	0.3"
	Length:	11.8"
Working temperature:		max. 1112°F

8.5.3 Condensate trap and fine dust filter



KEEP THE CONDENSATE TRAP IN THE VERTICAL POSITION DURING THE ANALYSIS; A WRONG POSITIONING MAY CAUSE CONDENSATE TO ENTER THE INSTRUMENT AND DAMAGE SENSORS.

AFTER EACH ANALYSIS, CHECK FOR ANY PRESENCE OF WATER IN THE CONDENSATE COLLECTION BOWL AND EMPTY IT, IF ANY. PUT THE PROBE BACK IN THE CASE ONLY AFTER YOU HAVE REMOVED CONDENSATE FROM THE TUBE AND THE EXPANSION TANK (SEE CHAPTER 'MAINTENANCE').

REPLACE THE FINE DUST FILTER IF IT HAS VISIBLE CRACKS, IS SIGNIFICANTLY DIRTY OR WET (SEE CHAPTER 'MAINTENANCE'). DO NOT PERFORM ANY MEASUREMENT WHEN THE FILTER IS REMOVED OR SIGNIFICANTLY DIRTY IN ORDER TO AVOID ANY RISK OF IRREVERSIBLE DAMAGES ON SENSORS. ON SENSORS.

The sample gas to be analyzed shall reach the measurement cells after being properly dehumidified and purified from the residual combustion products. For this purpose, a condensate trap is used, which consists of a transparent polycarbonate cylinder placed along the rubber hose of the sampling probe. Its purpose is to decrease the air speed so that the heavier fine dust particles can precipitate and the vapor in the combustion gases can condensate.

The condensate trap must be always kept in the vertical position in order to prevent condensate from touching the measurement cells. This is also the reason why it is important to periodically drain the trap at the end of each test (see chapter 'MAINTENANCE').

A replaceable low-porosity line filter is placed after the condensate trap aimed at keeping the solid particles suspended in the gases. It is recommended to replace the filter whenever significantly dirty (see chapter 'MAINTENANCE').

8.5.4 Connecting the gas sampling probe and water-trap assembly

As shown in [section 8.5](#) the gas sampling probe must be connected to the device as follows:

- The polarized male connector of the thermocouple must be connected to the lower part of the device in the **T1** socket. The improper insertion of the same is not possible thanks to the different lengths of the tips.
- The shorter hose of the probe must be inserted in the condensation trap with ant-dust filter ([see section 8.5.2](#)).
- The male connector of the filter assembly must be connected to the central female connector of the device marked with **"IN"**.
- The longer hose of the probe, which ends with a male connector, must be connected to the negative pressure input of the device marked with the letter **"P-"**.

The different diameter of the connectors does not allow improper connections: this avoids damage to the device.

8.5.5 Gas probe for industrial engines

This type of probe is typically used in processes where the fumes sampled are very dirty and must be pre-filtered directly in the stack, before entering into the dual-stage condensate trap equipped with a filter with a degree of filtration higher than the one inserted in the stack.

To preserve the internal system it is mandatory to filter the dust out of the fumes directly on the probe tip, using an AISI 316L stainless steel filter. Condensate and fumes are then separated by means of the two condensate traps connected to the same probe. The probe tip is provided with a flange that acts as a heatsink to make sure that, in case of very high temperature at the stack, the handle is not damaged by a temperature that might exceed 212 .. 248° F (max. allowed temperature).

Technical features:

Tip:	Material:	AISI 304 stainless steel
	Diameter:	0.3"
	Length:	29,5" rigid tip + flange, insertion depth 23.6"
Handle:	Material:	Nylon
	Color:	Black



Hose:	Material:	EPDM
	Length:	9.8 ft.
Filter:		AISI 316L sintered stainless steel, washable with ultrasonic bath or with solvents and steel brush.
Temperature sensor:		Type K thermocouple (Ni-NiCr) - IEC584 - Class 1
Pneumatic connectors:		Male - 0.35" diameter
		Male - 0.30" diameter
Temperature sensor connector:		TcK mignon size
Operating temperature:		max. 1472°F

8.5.6 Ambient CO probe

This special probe allows the ambient CO measurement before accessing the boiler room and just then, to measure the CO in the environment while the combustion analysis is performed (as, for example, compelled by the Spanish standard ES.02173.ES, Gas Natural Fenosa), prior entering the data "CO amb. ext." in the parameter "configuration measurement list".

The value of the ambient CO can be also printed along with the combustion analysis, if previously selected in the parameter "Print measurement list".

For further details refer to the probe instruction manual.

8.5.7 Combustion air temperature sensor

This probe is used to measure the temperature of the incoming combustion air.

Use: to be used when the sampling site of the combustion air is located in a different area than the boiler room or the heating plant; when the combustion air sampling site is located in a different place than the boiler room, the temperature of the combustion air can be very different compared with the temperature of the air in the boiler room, generating a less accurate efficiency calculation.

Technical features:

Tip:	Material:	AISI 304 stainless steel
	Diameter:	0.2"
	Length:	7.9" rigid tip
Adapter for thermowells:	Material:	AISI 303 stainless steel
	External diameter:	0.3" .. 0.6"
Temperature sensor:	Sensing element:	Type K thermocouple (Ni-NiCr) - IEC584 - Class 1
	Cable length:	6.6"
Connector:		TcK mignon size
Measurement range:		-4.0°F .. +392.0°F

Connection

As shown in [section 8.5](#) the probe must be connected to the instrument as follows:

- ♦ The polarized male connector of the thermocouple must be connected to the **T2** plug. The improper insertion of the same is not possible thanks to the different length of the tips.

8.5.8 Tc-K temperature measurement probe

Using the same input as for the Tc-K thermocouple 'T1' (i.e. the one used for gas temperature), it is possible to measure the supply and return water temperature. If this temperature is taken on the pipe itself, it is suggested to use contact probes with diameter matching as close as possible the pipe diameter.

Connection

As shown in [section 8.5](#) the probe must be connected to the device as follows:

- ♦ The polarized male connector of the thermocouple must be connected to the '**T1**' plug. The improper insertion of the same is not possible thanks to the different lengths of the tips.

8.5.9 Ionization current measurement probe

This special probe has been developed to extend the functions of the analyzer to check the quality of the combustion flame.

This probe allows the combustion analyzer to measure the current that is created within the combustion chamber between the chamber metal body and the measurement electrode.

Connection

As shown in [section 8.5](#) the probe must be connected to the device as follows:

The 8-poles mini-DIN type connector must be connected to the serial port on the analyzer ( [chapter 5](#)).



8.5.10 Draft measurement pressure gauge.

This device has been designed to extend the functions of the combustion analyzer to the draft measurement. It enables the combustion analyzer to measure the draft and generally the pressure with an higher accuracy and resolution than the internal sensor of the instrument.

Connection

As shown on the [section 8.5](#) the probe shall be connected to the instrument as follows:

- ♦ The draft gauge is provided with a female connector (\varnothing 0.35") of the same type of the one for the pressure inputs on the combustion analyzer. Thanks to this connector the draft gauge can be connected directly to the shorter male connector (\varnothing 9mm) of the flue gas sampling probe supplied.

The 8-pole MiniDin connector shall be connected to the serial port of the analyzer (**E** [chapter 5](#)).

8.5.11 Pressure Test Kit

Two types of pressure measurement kit are available:

- 1st Kit includes two 1mt hoses and two \varnothing 0.35" fittings; to be used for the differential pressure measurement.
- 2nd Kit includes one 1mt hose and one \varnothing 0.35" fitting for pressure measurement.

Connection

As shown on [section 8.5](#) the kits shall be connected to the instrument as follows:

- 1st hose connector shall be connected to the P+ connector, while the other hose connector shall be connected to the analyzer P- connector.
- 2nd The hose connector shall be connected to the analyzer P+ or P- connector.

8.5.12 Burner pressure verification probe

This probe must be used to measure the burner pressure of the gas-powered boiler so it can be regulated in real time. It is made of a silicone tube, 0.3"x0.1" and 3.3 ft. long, complete with connector for connecting to the analyser.

Connection

As shown on [section 8.5](#) the kits shall be connected to the instrument as follows:

The hose connector shall be connected to the analyser P+ connector.

8.5.13 Connection to PC

By using the USB cable supplied or via Bluetooth connection (optional) it is possible to connect the device to a personal computer after installing the dedicated software supplied.

Functions:

- View the details of the analyser.
- See and/or export (in csv format, importable into excel, and/or pdf) or delete the stored analyses.
- Configure the device.

8.5.14 Connection to battery charger

Supplied with the device there is a power plug with output 5V ---, 2A to charge the internal batteries. In [section 5](#) you can see the socket for the connection of the battery charger to the device. Once it has started charging, the display turns on and the state of charge of the battery is displayed.

9.0 POWER ON - OFF

9.1 Starting the device



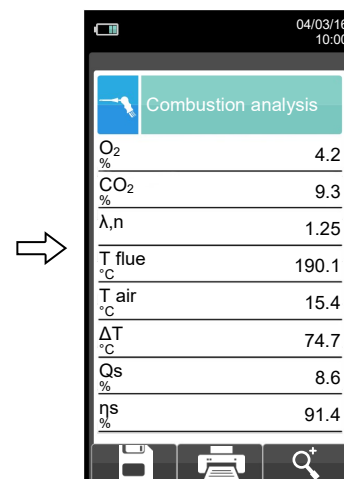
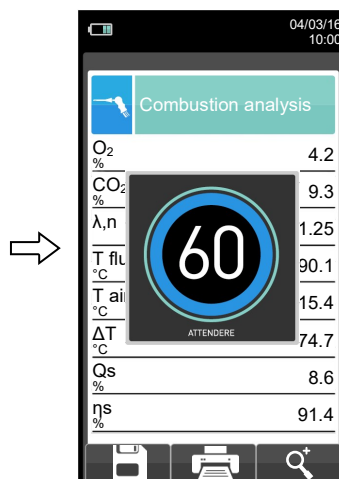
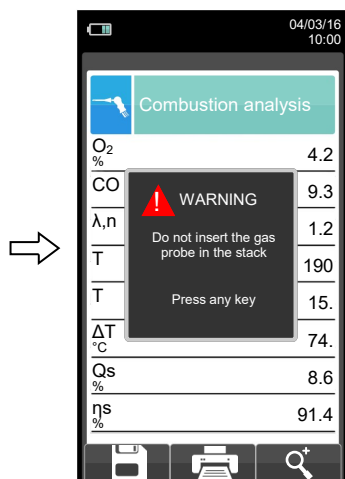

Press and hold for a few seconds.



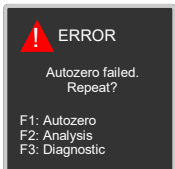





 **DURING INSTRUMENT AUTOZERO, THE SAMPLING PROBE MUST NOT BE INSERTED IN THE STACK.**

 **During autozero, you can only use the menus that do not require autozero.**

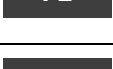
 **This error message is displayed if the autozero of the device is not successfully completed.**

KEY	FUNCTION
	Activate the context keys shown on the display.
	Goes through the measurements available.
	Activates the context key located in the left side of the display.
	Returns to the previous screen.

CONTEXT KEY	FUNCTION
	Repeats autozero (is shown in the case of an error).
	The device will suspend autozero and display the screen "Combustion Analysis"; it is possible to carry out the analysis of combustion (displayed in the case of an error).
	The device displays the screen "Sensor Diagnostics" (displayed in the case of an error).
	Save analysis.
	Print the paper print-out according to the settings.
	Zoom. By pressing this interactive key repeatedly, the device displays the following sequence: AAA → AAA → AAA → AAA

10.1 Configuration menu

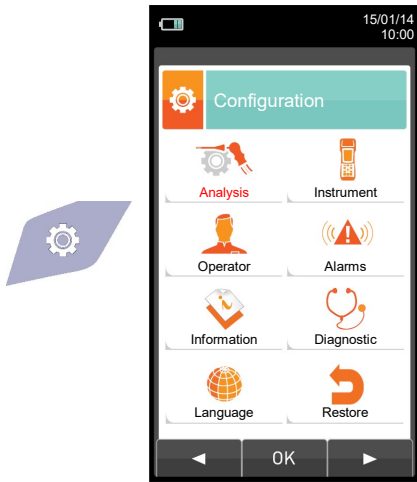

KEY	FUNCTION
	Activate the context keys shown on the display.
	Returns to the previous screen.

CONTEXT KEY	FUNCTION
	Selects the available parameters.
	Enters in the selected parameter setting.
	Selects the available parameters.

PARAMETER	FUNCTION
Analysis	Through this menu the user can configure the available parameters for a proper combustion analysis. SEE SECTION 10.2.
Instrument	This menu is used to configure the instrument's reference parameters. SEE SECTION 10.3.
Operator	In this sub menu you can enter or change the name of the operator that will carry out the analysis. Up to 8 lines are available. Also, you can select the name of the operator that will carry out the analysis and this will be printed on the analysis report. SEE SECTION 10.4.
Alarm	<p>This submenu allows the user to set and memorize 10 alarms, defining the monitored parameter for each (gas, pressure, Ta, Tf), the alarm threshold and relative unit of measurement and whether it is a low or high-level alarm. Low-level alarms are triggered when the reading drops below the defined threshold, whereas high-level alarms are triggered when the reading rises above the defined threshold. When an alarm threshold is crossed, the instrument emits an intermittent audible alarm in addition to showing a visible alarm wherein the background of the name of the relative reading will start flashing in the analysis screen. SEE SECTION 10.5.</p>
Information	This menu provides information regarding instrument status. SEE SECTION 10.6.
Diagnostic	The user, with this menu, can check any anomalies of the device. SEE SECTION 10.7.
Language	Set the desired language for the various menus and the paper print-out. SEE SECTION 10.8.
Restore	Restore factory settings. SEE SECTION 10.9.

10.2 Configuration → Analysis

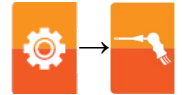

KEY	FUNCTION
	Activate the context keys shown on the display.
	Returns to the previous screen.

CONTEXT KEY	FUNCTION
	Selects the available parameters.
	Enters in the selected parameter setting.
	Selects the available parameters.

PARAMETER	DESCRIPTION
Fuel	Lets the user select the type of fuel to be used during analysis. Fuel selection can be done either from this menu or during the analysis itself. By selecting the sub menu Fuel coefficients the user can view the characteristics of the fuels used in the calculation of performance. SEE SECTION 10.2.1.
Condensation	The burner efficiency figure when condensation takes place is influenced by atmospheric pressure and humidity of the combustion air. As the atmospheric pressure is hardly precisely known, the operator is asked to enter a related parameter, i.e. the altitude of the place above the sea level, from which the pressure is then derived once the dependency from atmospheric conditions is neglected. In calculations the value of 101325 Pa is assumed as atmospheric pressure at sea level. Further the air relative humidity input is allowed, being this calculated at the combustion air temperature as measured from the instrument; in case this value is unknown the operator is recommended to enter 50% for this value. SEE SECTION 10.2.2.
O ₂ reference	In this mode the user can set the oxygen percentage level to which pollutant emission values detected during analysis will be referenced. SEE SECTION 10.2.3.
NO _x NO _x /NO ratio	NO _x /NO: all the nitrogen oxides which are present in the flue emissions (Nitrogen oxide = NO, Nitrogen dioxide = NO ₂); total nitrogen oxides = NO _x (NO + NO ₂). In the combustion processes, it is found out that the NO ₂ percentage contained in the gas is not far from very low values (3%); hence it is possible to obtain the NO _x value by a simple calculation without using a direct measurement with a further NO ₂ sensor. The NO ₂ percentage value contained in the gas can be however set at a value other than 3% (default value). SEE SECTION 10.2.4.
Measure units	Through this submenu the user can modify the units of measurement for all the analysis parameters, depending on how they are used. SEE SECTION 10.2.5.
Autozero	In this sub menu the user can change the length of the autozero cycle of the analyzer, start it manually and set the length of the sensor cleaning cycle that will be performed by the instrument at switch-off. SEE SECTION 10.2.6.
Measures list	In this sub menu the user can see the list of measurements that the device can perform. With the interactive keys, the user can add, delete or move a selected measurement. SEE SECTION 10.2.7.
Air temp.	In this submenu there is a possibility to acquire or manually enter the combustion air temperature. SEE CHAPTER 10.2.8.

10.2.1 Configuration → Analysis → Fuel

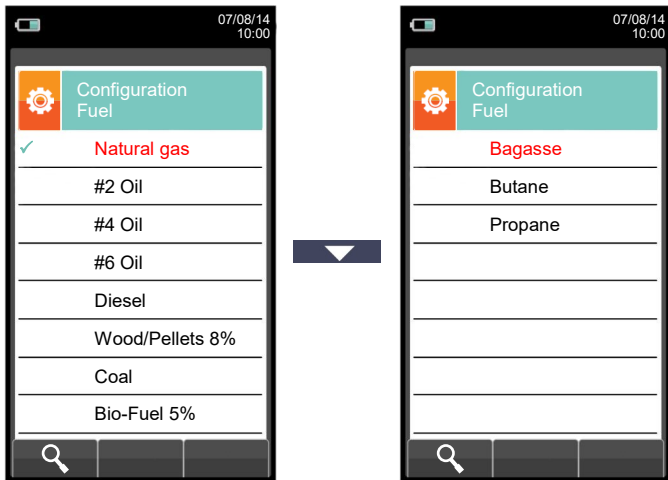
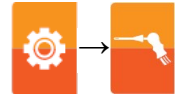

KEY	FUNCTION
	Activate the context keys shown on the display.
	The arrows select each line displayed.
	Confirms the choice of fuel to be used during the analysis.
	Returns to the previous screen.

CONTEXT KEY	FUNCTION
	Shows the details of the selected fuel (see example below).
	Returns to the previous screen.

Example:

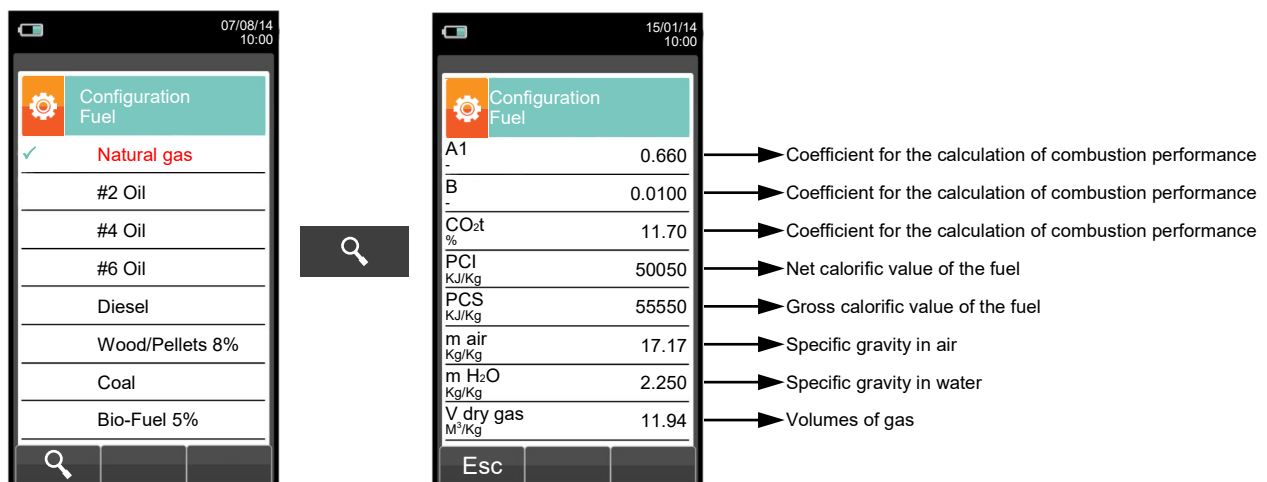

10.2.2 Configuration → Analysis → Condensation

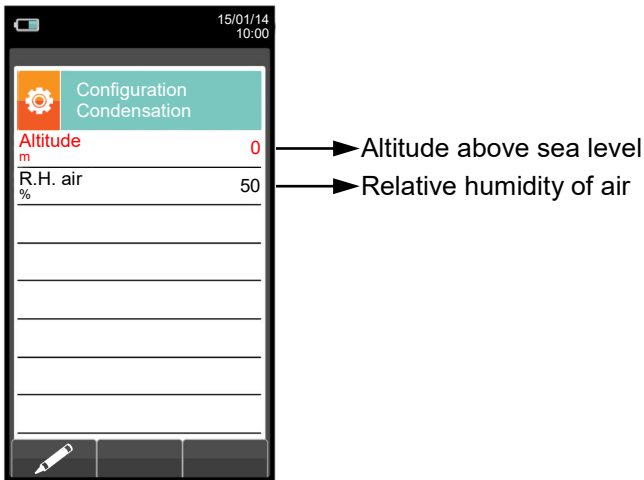
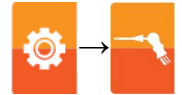

KEY	FUNCTION
	Activate the context keys shown on the display.
	The arrows select each line displayed (the selected line is red). In edit mode, it scrolls through the suggested values.
	Enters the modify mode for the selected parameter, then confirms the modification.
	When pressed in modify mode cancels the selection made, otherwise returns to the previous screen.

CONTEXT KEY	FUNCTION
	Enters the modification mode for the selected parameter.
	Confirms the modification.

Example:

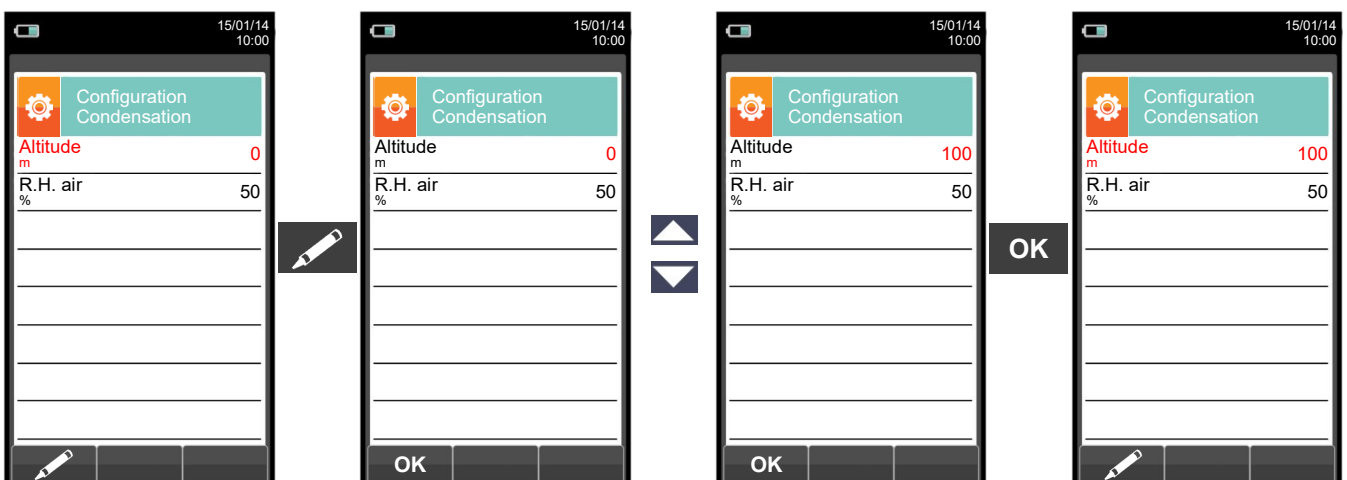

10.2.3 Configuration → Analysis → Reference O₂

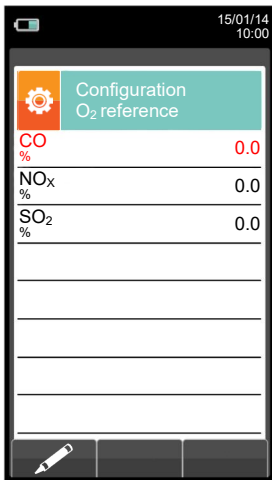
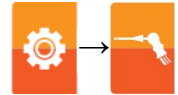

- ▶ Percentage of Oxygen in CO measurement
- ▶ Percentage of Oxygen in NO_x measurement
- ▶ Percentage of Oxygen in SO₂ measurement

KEY	FUNCTION
	Activate the context keys shown on the display.
	Keys '▲' and '▼' select any line shown on the display (the selected line is displayed in red). When in modify mode, sets the desired value.
	Enters the modify mode for the selected parameter, then confirms the modification.
	When pressed in modify mode cancels the selection made, otherwise returns to the previous screen.

CONTEXT KEY	FUNCTION
	Enters the modify menu for the selected parameter.
	Confirms the modification.

Example:

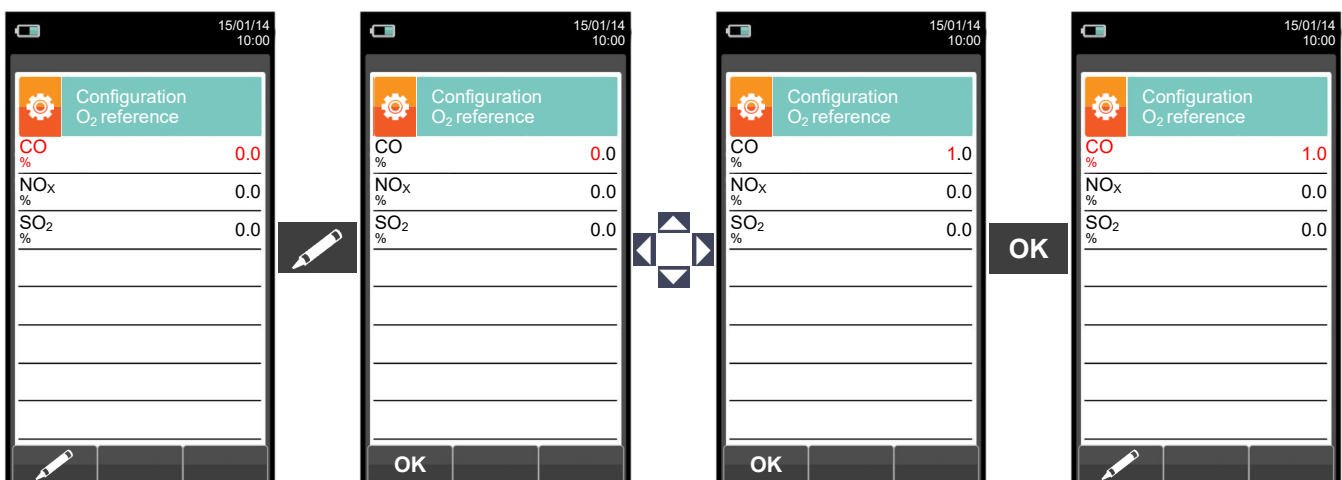

10.2.4 Configuration → Analysis → NO_x/NO ratio

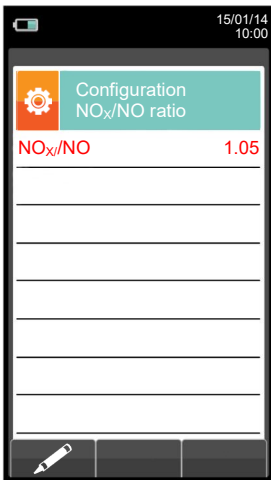
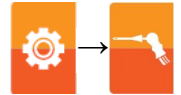

KEY	FUNCTION
	Activate the context keys shown on the display.
	When in modify mode, sets the desired value.
	Enters edit mode of the selected element and then confirms the change.
	When pressed in modify mode cancels the selection made, otherwise returns to the previous screen.

CONTEXT KEY	FUNCTION
	Enters edit mode.
	Confirms the modification.

Example:

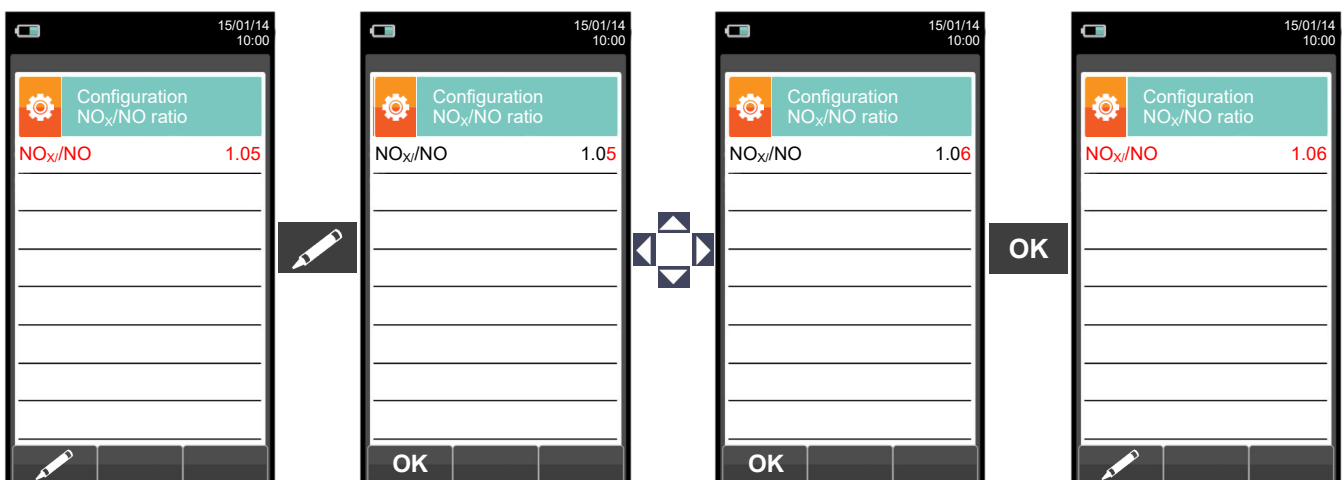

10.2.5 Configuration → Analysis → Measurement units

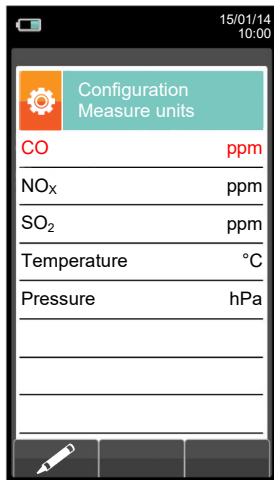
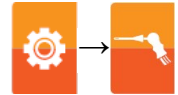

- Measurement unit can be set as: ppm - mg/m³ - mg/kWh - g/GJ - g/m³ - g/kWh - % - ng/J
- Measurement unit can be set as: ppm - mg/m³ - mg/kWh - g/GJ - g/m³ - g/kWh - % - ng/J
- Measurement unit can be set as: ppm - mg/m³ - mg/kWh - g/GJ - g/m³ - g/kWh - % - ng/J
- Measurement unit can be set as: °C - °F
- Measurement unit can be set as: hPa - Pa - mbar - mmH₂O - mmHg - inH₂O - psi



The measurement units mg/m³ and g/m³ are referred to Normal pressure and temperature conditions, P = 101325 Pa and T = 0 °C.

KEY	FUNCTION
	Activate the context keys shown on the display.
	Keys '▲' and '▼' select any line shown on the display (the selected line is displayed in red). When in modify mode, sets the desired value.
	Enters edit mode of the selected element and then confirms the change.
	When pressed in modify mode cancels the selection made, otherwise returns to the previous screen.

CONTEXT KEY	FUNCTION
	Enters the modification mode for the selected parameter.
	Confirms the modification.

Example:

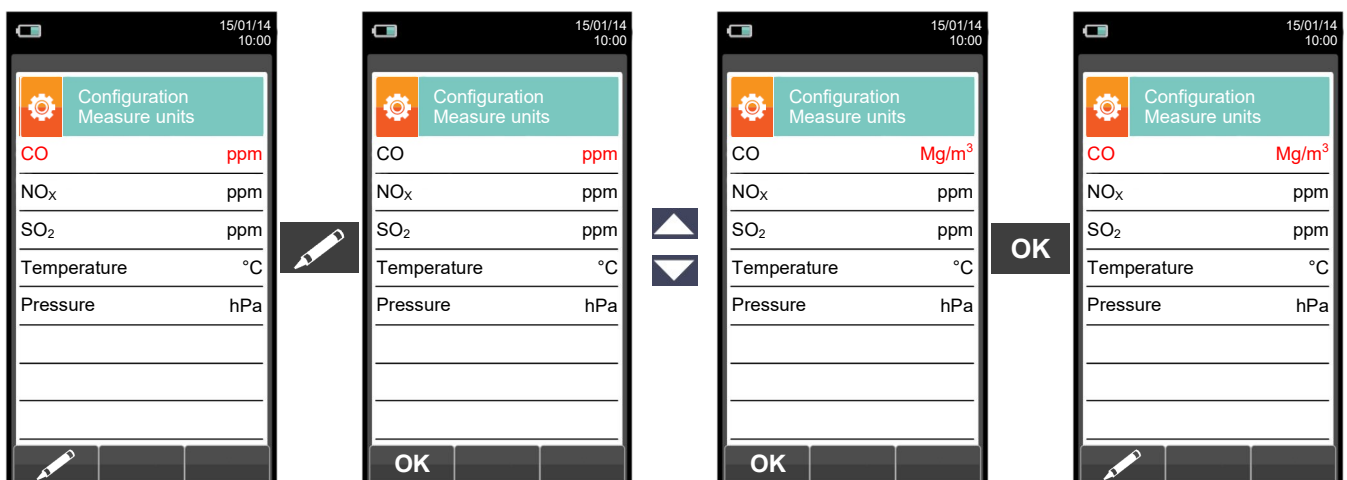

10.2.6 Configuration → Analysis → Autozero

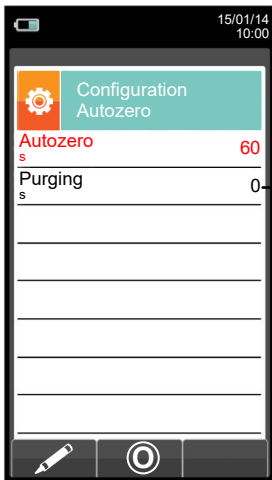
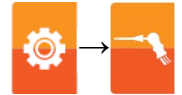

→ Duration of autozero, expressed in seconds.
 → Duration of the cleaning cycle, expressed in seconds.

KEY	FUNCTION
	Activate the context keys shown on the display.
	When in modify mode, sets the desired value.
	Enters edit mode of the selected element and then confirms the change.
	When pressed in modify mode cancels the selection made, otherwise returns to the previous screen.

CONTEXT KEY	FUNCTION
	Enters the modify menu for the selected parameter.
	Confirms the modification.
	Starts autozero for the selected duration.

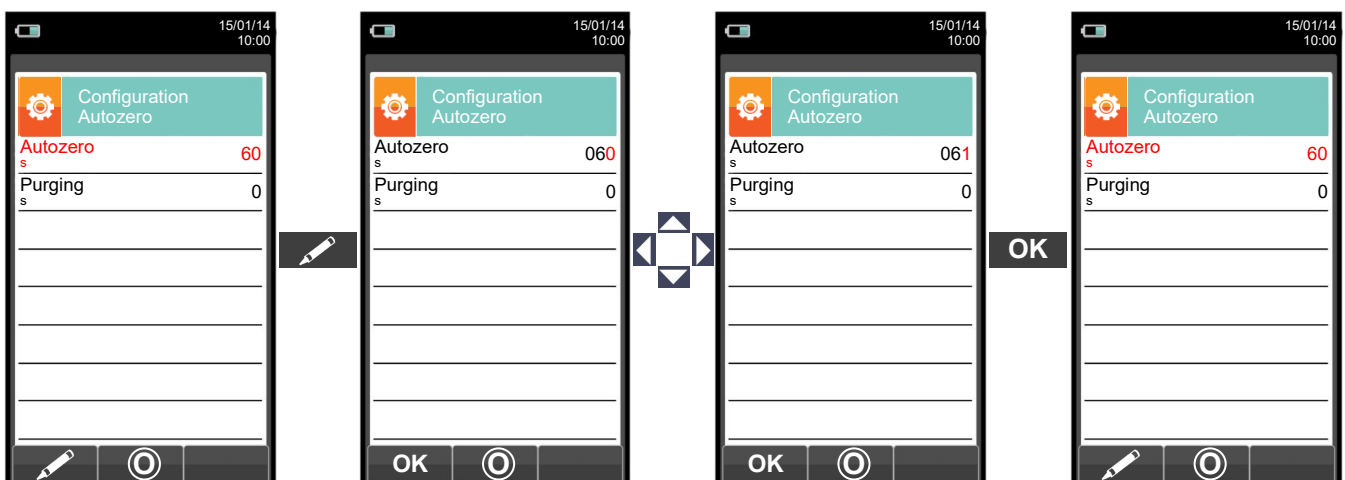

Example:



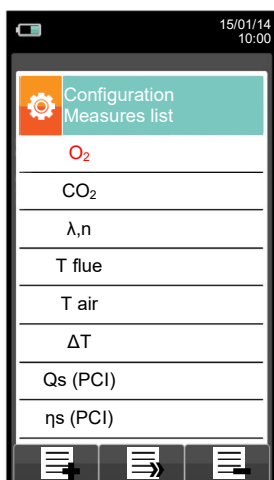







10.2.7 Configuration → Analysis → Measures list



 FOR FURTHER DETAILS SEE THE [ANNEX E](#)

KEY	FUNCTION
	Activate the context keys shown on the display.
	Select each line displayed (the line selected is red). In edit mode, it sets the desired value.
	When pressed in modify mode cancels the selection made, otherwise returns to the previous screen.

CONTEXT KEY	FUNCTION
	Adds a line to the list of available measurements.
	Activates the movement of a measurement from its current position.
	Deletes a measurement from the list of available measurements.
	After the activation of the function '  ': It scrolls through the available measurements. After the activation of the function '  ': It moves the element from its current position.
	Confirms the operation.
	Cancels the operation.

 OTHER THAN THE MEASUREMENT LIST ABOVE, IT IS POSSIBLE TO VISUALIZE THE MEASURE OF THE DETECTED GAS ALSO IN PPM, DEPENDING ON THE KIND OF MEASUREMENT CELL IN THE INSTRUMENT. IF IT IS NECESSARY TO MEASURE THE VALUE OF GAS WITH TWO DIFFERENT MEASUREMENT UNITS, SELECT IN THE MEASUREMENTS LIST THE DESIRED GAS IN PPM AND CHANGE THE MEASUREMENT UNIT FOR THE SAME GAS IN THE "CONFIGURATION->ANALYSIS->MEASUREMENT UNIT" SCREEN. NOW THE INSTRUMENT ACQUIRES THE MEASURE WITH TWO DIFFERENT UNITS (PPM AND THE ONE PREVIOUSLY SET)

Example:

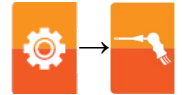

1. Add a measurement to the list - example

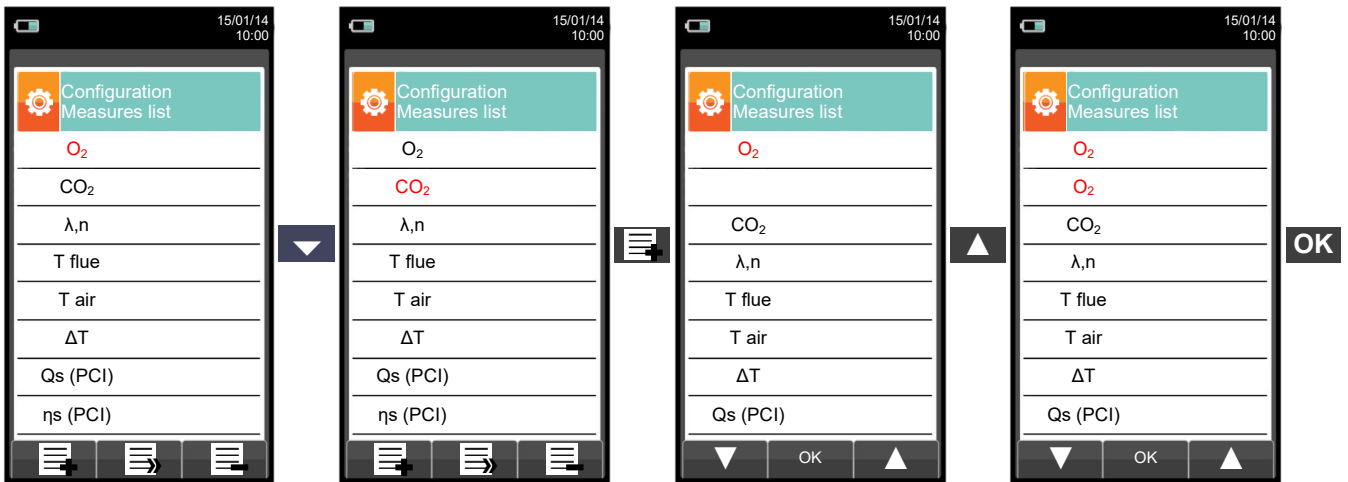

2. Change the position of a measurement - example

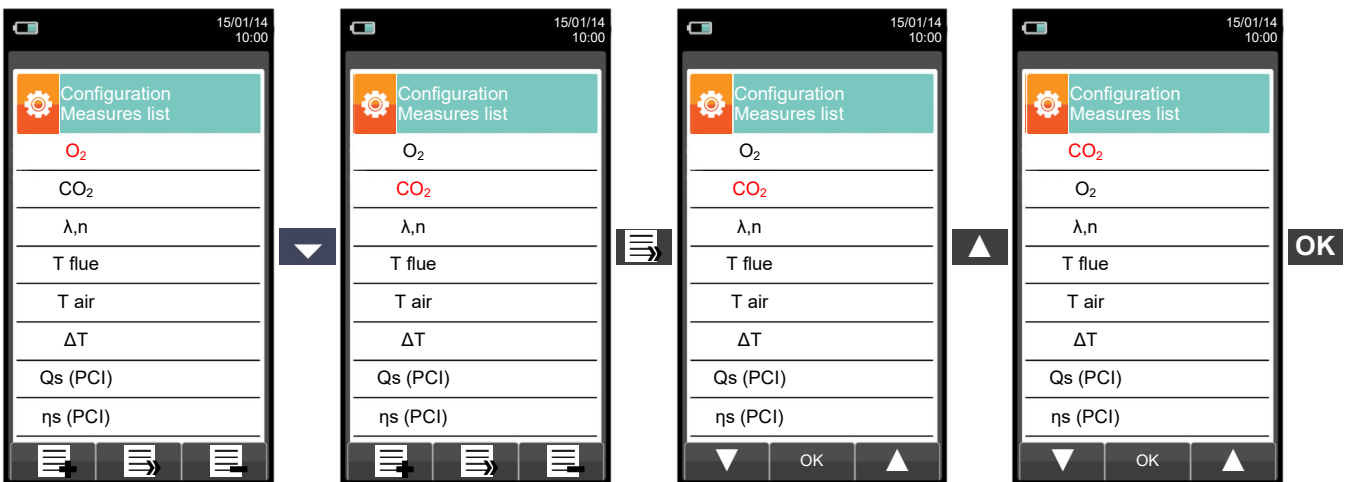

3. Delete a measurement from the list - example

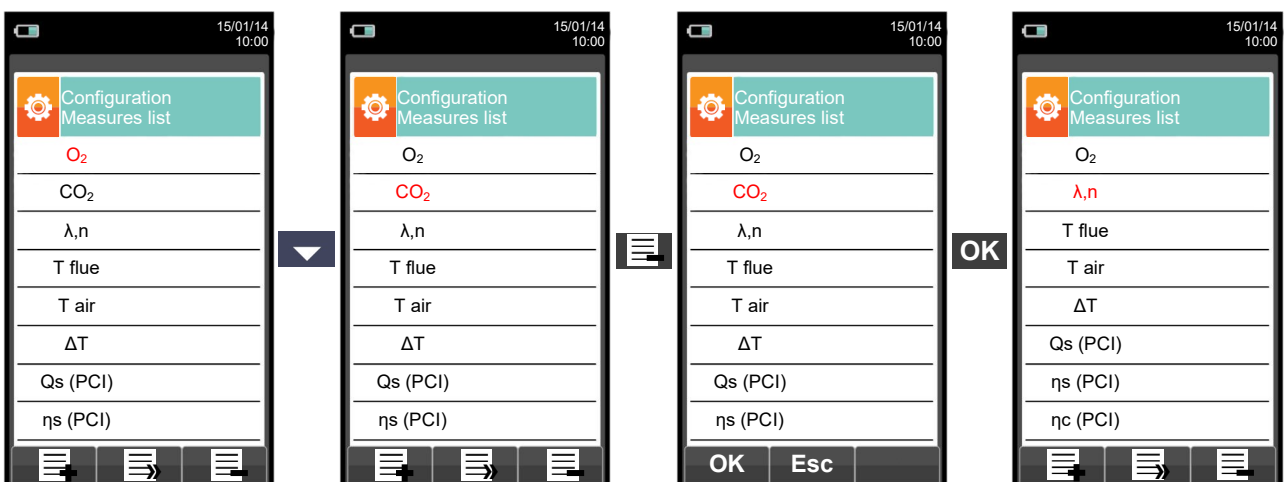

10.2.8 Configuration → Analysis → Air temperature

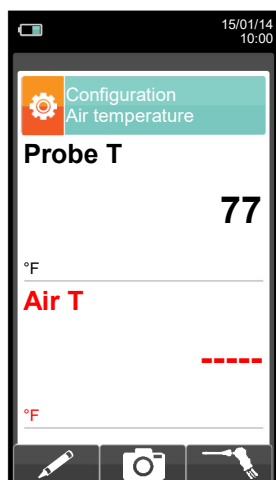

KEY	FUNCTION
	Activate the context keys shown on the display.
	When in modify mode, sets the desired value.
	Activates the context key located in the left side of the display.
	Returns to the previous screen without saving the changes made.

CONTEXT KEY	FUNCTION
	Accesses the Editing mode of the parameter 'Air T': it is possible to enter the desired value of the combustion air temperature that will be used in the combustion analysis.
	It saves the value, acquired or entered in the parameter 'Air T'.
	Acquires the temperature value detected from the sampling probe. That value is reported in the parameter 'Air T'.
	Confirms the operation.

10.3 Configuration→Instrument

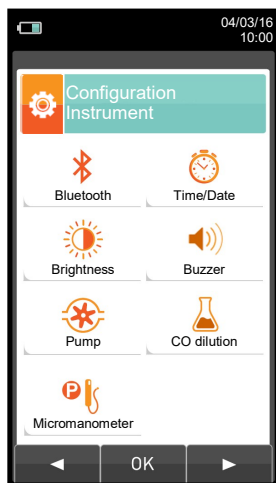

KEY	FUNCTION
	Activate the context keys shown on the display.
	Returns to the previous screen.
CONTEXT KEY	FUNCTION
	Selects the available parameters.
	Enters in the selected parameter setting.
	Selects the available parameters.

PARAMETER	DESCRIPTION
 Bluetooth	<p>Through this sub menu the user can turn on and off the instrument Bluetooth wireless communication with a PC or PDA.</p> <div style="border: 1px solid black; padding: 5px; text-align: center;"> WHEN THE INSTRUMENT BLUETOOTH INTERFACE IS TURNED ON, THE BATTERY LIFE IS REDUCED DOWN TO 10 HOURS. </div> <p>SEE SECTION 10.3.1.</p>
 Time/Date	<p>This allows the current time and date to be set. The user can select the date and hour format either in EU (European) or USA (American) mode.</p> <p>SEE SECTION 10.3.2.</p>
 Brightness	<p>The display contrast may be increased or decreased by acting on cursor keys. This operation may be performed even when the introductory screen is active.</p> <p>SEE SECTION 10.3.3.</p>
 Buzzer	<p>The instrument is fitted with an internal buzzer which is mainly used to signal any faults and/or alarms. In this submenu you can enable or disable the buzzer or enable it and mute the key tones.</p> <p>SEE SECTION 10.3.4.</p>
 Pump	<p>In this sub menu the user can turn the gas suction pump off or back on. Also, if the pump is on, the user can view the flow of the pump in litres per minute. It is not possible to turn off the pump during an autozero cycle.</p> <p>SEE SECTION 10.3.5.</p>
 CO dilutor	<p>The CO sensor is protected by a pump which, in case of need, can inject clean air in the gas path in order to dilute the gas concentration measured by the sensor. This function can be either triggered by the overcoming of a CO concentration threshold which can be set by the user or, in case it is known that the flue gases contain high CO concentration, kept enabled any time, independently of CO concentration.</p> <div style="border: 1px solid black; padding: 5px; text-align: center;"> The main purpose of the CO Auto-Dilution feature is for protection for CO sensor against over-saturation. The accuracy and resolution of the CO measurement is not as great when this feature is enabled. </div> <p>SEE SECTION 10.3.6.</p>
 Micromanometer	<p>Allows to configure the micromanometer input (optional) as P+ or P- port. In case P- is selected, the sign of pressure is inverted.</p> <p>SEE SECTION 10.3.7.</p>

10.3.1 Configuration → Instrument → Bluetooth

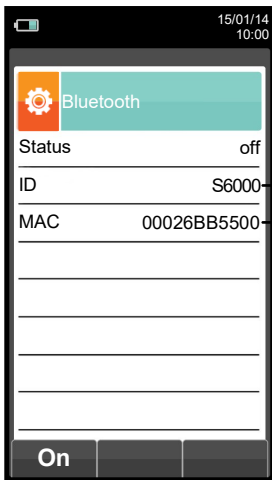

Bluetooth enabling / disabling
 Instrument name
 MAC address detected

KEY	FUNCTION
	Activate the context keys shown on the display.
	Also activates the context key shown on the display.
	Returns to the previous screen.

CONTEXT KEY	FUNCTION
	Turns on Bluetooth communication.
	Turns off Bluetooth communication.

10.3.2 Configuration→Instrument→Time/Date

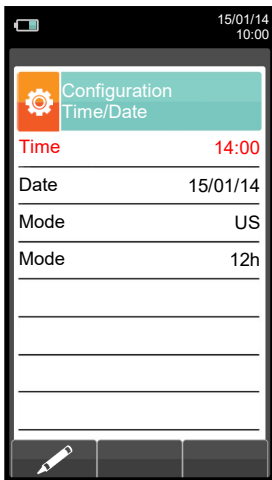

- ▶ Time, in the chosen format
- ▶ Date, in the chosen format
- ▶ Date format: EU (Europe) or USA (America)
- ▶ Time format: 24h or 12h

KEY	FUNCTION
	Activate the context keys shown on the display.
	When in modify mode, sets the desired value.
	Enters edit mode of the selected element and then confirms the change.
	When pressed in modify mode cancels the selection made, otherwise returns to the previous screen.

CONTEXT KEY	FUNCTION
	Enters edit mode of the selected parameter.
	Confirms the modification.

10.3.3 Configuration→Instrument→Brightness

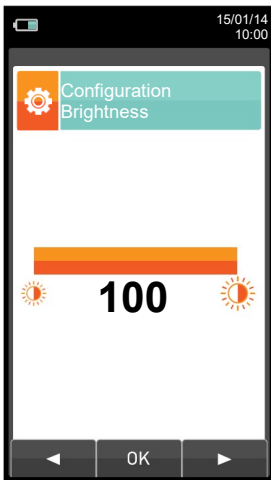

KEY	FUNCTION
	Activate the context keys shown on the display.
	Increases or decreases the brightness of the display.
	Confirms the modification.
	When pressed in modify mode cancels the selection made, otherwise returns to the previous screen.

CONTEXT KEY	FUNCTION
	Decreases the brightness of the display.
	Confirms the setting.
	Increases the brightness of the display.

10.3.4 Configuration→Instrument→Buzzer

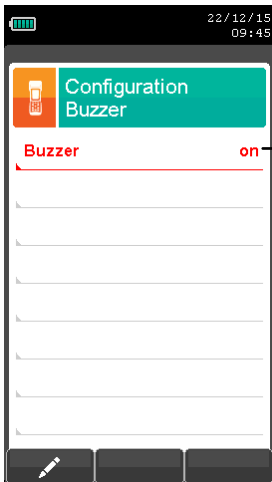

Available settings :

- on:** the buzzer is enabled (key tones and signalling of faults/alarms are enabled).
- limited:** the buzzer is enabled in a limited mode (key tones are disabled, while signalling of faults/alarms is enabled).
- off:** the buzzer is disabled.

KEY	FUNCTION
	Activate the context keys shown on the display.
	When in modify mode, sets the desired value.
	Enters edit mode of the selected element and then confirms the change.
	When pressed in modify mode cancels the selection made, otherwise returns to the previous screen.

CONTEXT KEY	FUNCTION
	Enters edit mode of the selected parameter.
	Confirms the modification.

10.3.5 Configuration→Instrument→Pump

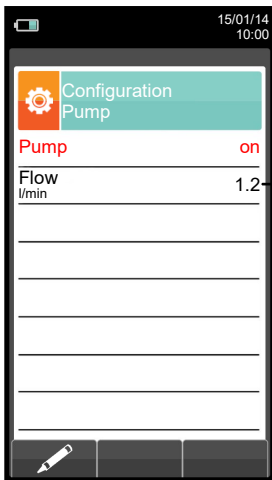

Displays the flow of the pump, expressed in litres per minute.

KEY	FUNCTION
	Activate the context keys shown on the display.
	When in modify mode, sets the desired value.
	Enters edit mode of the selected element and then confirms the change.
	When pressed in modify mode cancels the selection made, otherwise returns to the previous screen.

CONTEXT KEY	FUNCTION
	Enters edit mode: it is possible to turn the gas suction pump on or off.
	Confirms the modification.

10.3.6 Configuration→Instrument→CO dilution

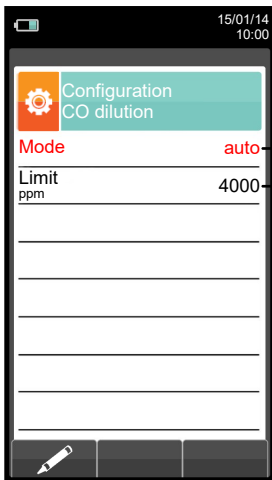

Available settings: auto, on or off

Threshold that activates the dilution pump (available only if the "Mode" parameter is set to "auto").

KEY	FUNCTION
	Activate the context keys shown on the display.
	Select each line displayed (the line selected is red). In edit mode, it sets the desired value.
	Enters edit mode of the selected element and then confirms the change.
	When pressed in modify mode cancels the selection made, otherwise returns to the previous screen.

CONTEXT KEY	FUNCTION
	Enters edit mode of the selected parameter.
	Confirms the modification.

10.3.7 Configuration → Instrument → Micromanometer

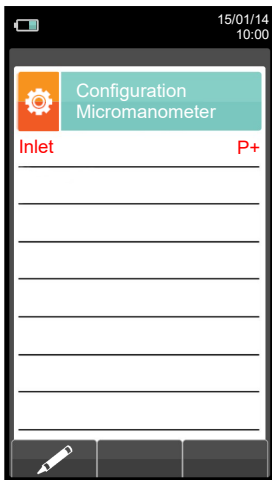

→ Sets the input used for the test: P+ or P-

KEY	FUNCTION
	Activate the context keys shown on the display.
	In edit mode, it sets the desired input.
	Enters edit mode of the selected element and then confirms the change.
	When pressed in modify mode cancels the selection made, otherwise returns to the previous screen.

CONTEXT KEY	FUNCTION
	Enters edit mode of the selected parameter.
	Confirms the modification.

10.4 Configuration→Operator

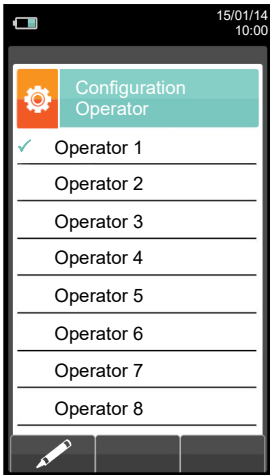
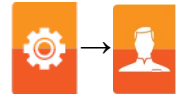

KEY	FUNCTION
	Activate the context keys shown on the display.
	In "edit text": Moves the cursor on the box corresponding to the letter or number required to form the word.
	In "Operator Configuration": Scrolls through the available operators.
	In "edit text": Confirms text input. In "Operator Configuration": selects the operator who will carry out the analysis; the operator is highlighted with the symbol "✓".
	Returns to the previous screen. In "edit text" goes back to the previous screen, without saving any changes.

CONTEXT KEY	FUNCTION
	Enters edit mode of the selected line: it is possible to enter the name of the operator (24 characters available).
	Confirms the selected letter or digit.
	Cancel the letter or digit before the cursor.
	Cycles through uppercase, lowercase, symbols and special characters.

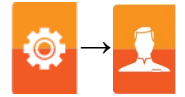

Example:

1. Edit text

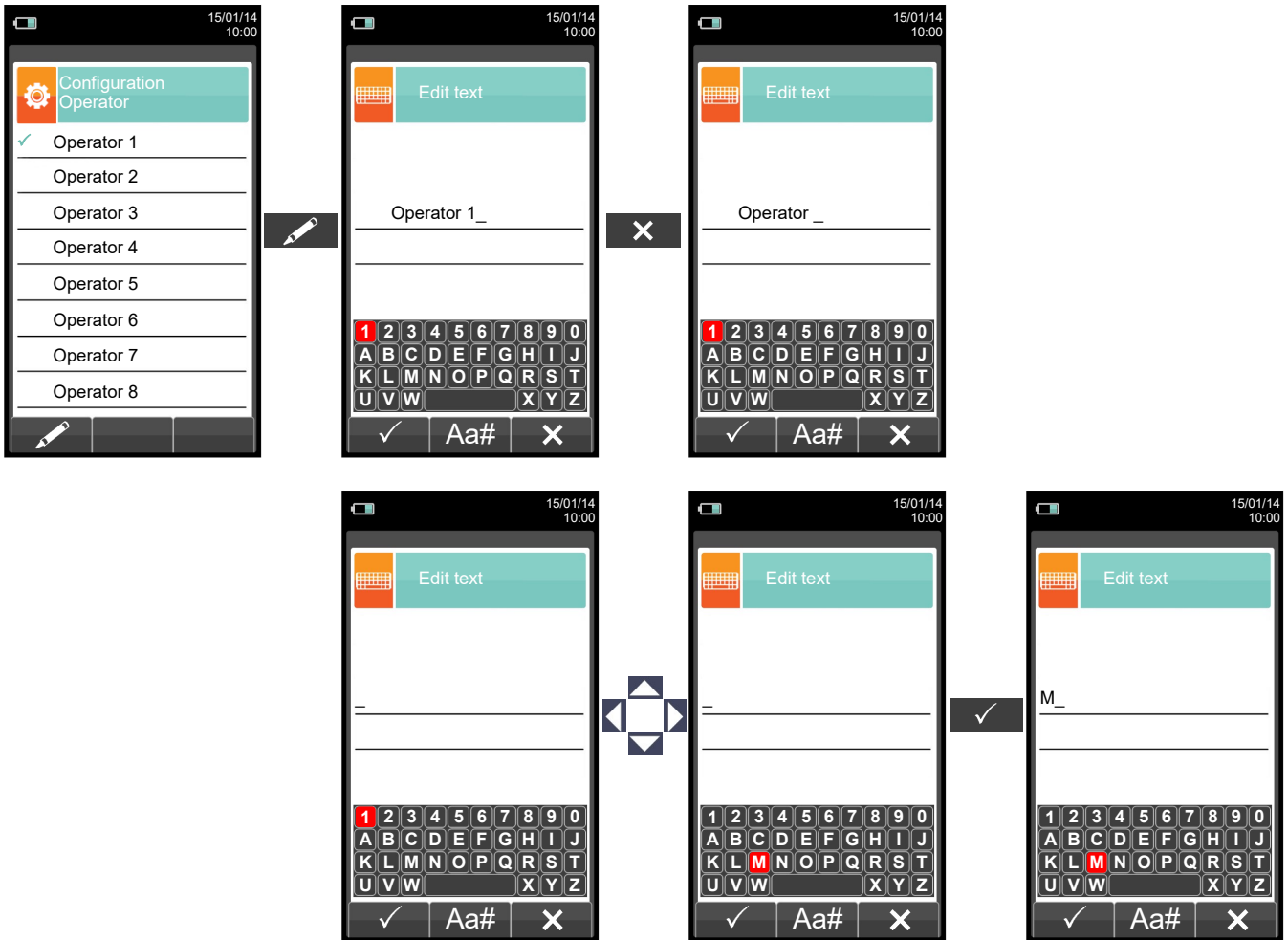

2. Select the operator who will carry out the analysis

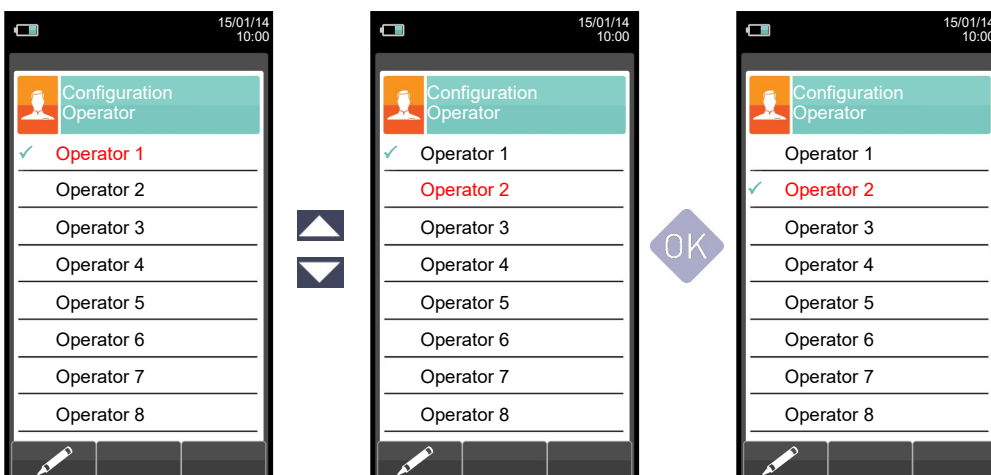

10.5 Configuration → Alarm

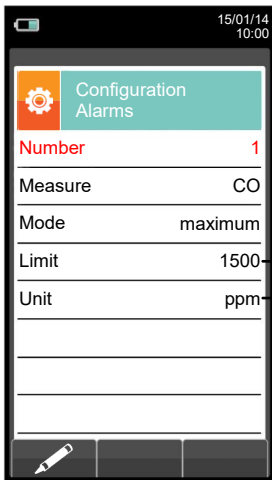

- ▶ Number of the alarm set
- ▶ Monitored parameter: O₂ - CO - NO - NO₂ - P diff - P low - P ext - T1 - T2
- ▶ Type of alarm set: maximum - minimum - off
- ▶ Threshold setting for the alarm: ±999999.999
- ▶ Measurement unit for the threshold set: ppm, mg/m³, mg/kWh, g/GJ, g/m³, g/kWh, % ng/J

KEY	FUNCTION
	Activate the context keys shown on the display.
	Keys '▲' and '▼' select any line shown on the display (the selected line is displayed in red). When in modify mode, sets the desired value.
	Enters the modify mode for the selected parameter, then confirms the modification.
	When pressed in modify mode cancels the selection made, otherwise returns to the previous screen.

CONTEXT KEY	FUNCTION
	Enters the modify menu for the selected parameter.
	Confirms the modification.

Alarm activation flow chart and suggested correctional actions

Type MAX. alarm activation

Type MIN. alarm activation

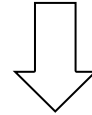
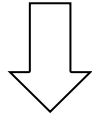

- Buzzer activation.
- The measure blinks on the display.

- Buzzer activation.
- The measure blinks on the display.

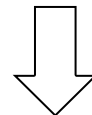
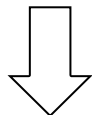

- Regulate the boiler correctly.
- The alarm is switched off automatically, if the gas concentration goes back below the set alarm threshold minus the hysteresis value.

- Regulate the boiler correctly.
- The alarm is switched off automatically, if the gas concentration is higher than the set alarm threshold plus the hysteresis value.

10.6 Configuration→Information

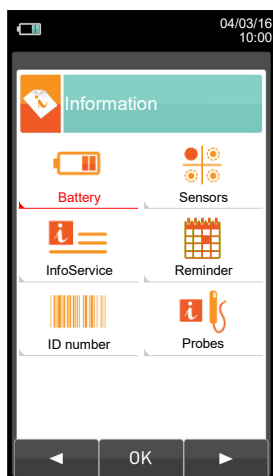

KEY	FUNCTION
	Activate the context keys shown on the display.
	Returns to the previous screen.

CONTEXT KEY	FUNCTION
	Selects the available parameters.
	Enters in the selected parameter setting.
	Selects the available parameters.

PARAMETER	DESCRIPTION
 Battery	Displays the current battery power status in percentage from 0 to 100%, both in text and graphically. SEE SECTION 10.6.1.
 Sensors	It allows to check which sensors are installed on the instrument, and in which position they are installed. The instrument automatically detects whether a sensor has been either added or removed. The screen page allows whether to accept the new configuration or ignore the change performed. SEE SECTION 10.6.2.
 Infoservice	This submenu contains details regarding the nearest Service Center to be contacted in the event of instrument fault or ordinary maintenance. The instrument model, serial number and firmware version are also displayed, thus allowing for a quick product identification. SEE SECTION 10.6.3.
 Reminder	Accessing this menu you can see the calibration's expiration date of the instrument, inserted by factory or assistance center. The menu is protected with a password: password is " 1111 ". SEE CHAPTER 10.6.4.
 ID number	Not available.
 Probes	Displays useful information on the probe connected to the serial cable connector visible in E in section 5 (Description of the Components of the Combustion Analyzer). SEE SECTION 10.6.5.

10.6.1 Configuration→Information→Battery

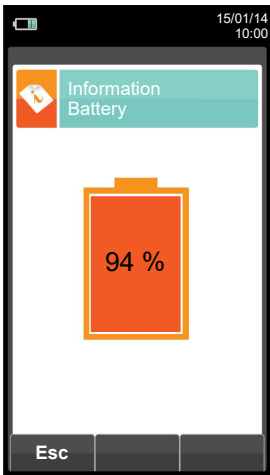

KEY	FUNCTION
	Activate the context keys shown on the display.
	Returns to the previous screen.

CONTEXT KEY	FUNCTION
	Returns to the previous screen.

10.6.2 Configuration→Information→Sensor

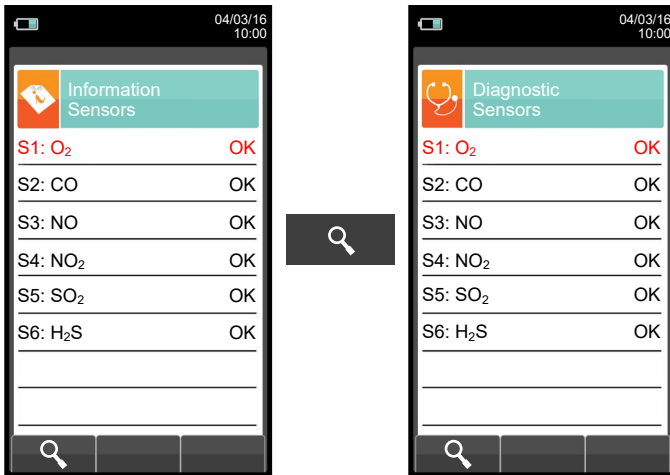

For further information, [see section 10.7.1.](#)

KEY	FUNCTION
	Activate the context keys shown on the display.
	Returns to the previous screen.

CONTEXT KEY	FUNCTION
	Displays the details of the main features of the sensors installed.
	Returns to the previous screen.

This screen displays, for each position, the following messages:

MESSAGE	DESCRIPTION
OK	Sensor configured OK (normal operation).
-----	Sensor is not communicating or has been removed.
The name of the detected gas is flashing	New sensor detected.
Pos err	Detected sensor in wrong position.
Volt err	Detected voltage is out of the normal operating range; repeat the autozero.
Curr err	Detected current is out of the normal operating range; repeat the autozero.

Error messages displayed:

MESSAGE	DESCRIPTION
Cal err	Calibration error.
Data err	Sensor not recognized.
No cal	Sensor not calibrated.

10.6.3 Configuration → Information → InfoService

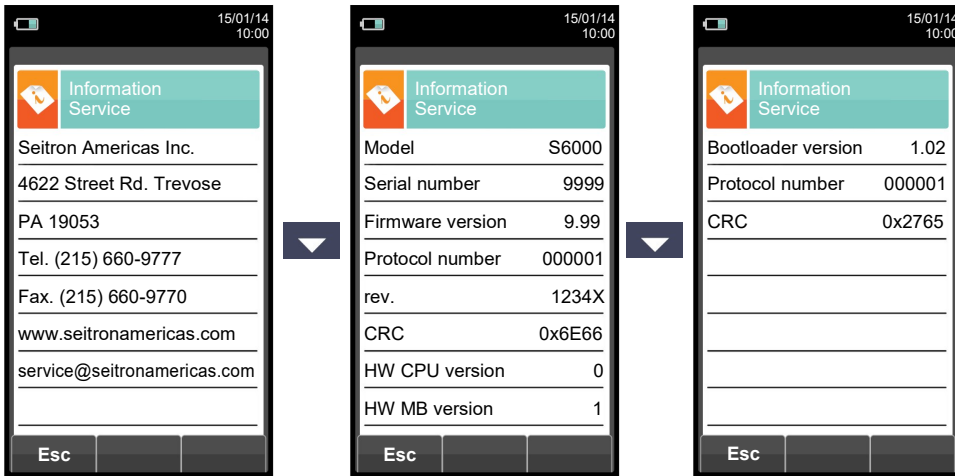

KEY	FUNCTION
	Activate the context keys shown on the display.
	Toggle view between next or previous screen.
	Returns to the previous screen.

CONTEXT KEY	FUNCTION
	Returns to the previous screen.

10.6.4 Configuration→Information→Reminder

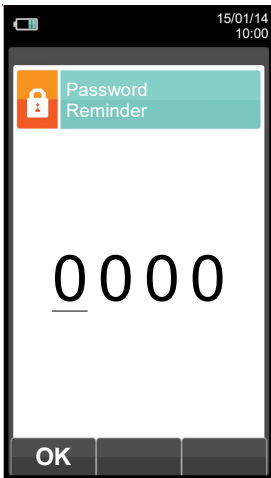

KEY	FUNCTION
	Activate the context keys shown on the display.
	Sets the password. The password is: 1111.
	Returns to the previous screen.

CONTEXT KEY	FUNCTION
	Confirm password and enter the menu "Reminder".
	Returns to the previous screen.
	Displays the information about the assistance center.
	Temporarily ignores the message. Next time the instrument will be turned on, the remainder will be displayed again.
	Permanently ignores the message.

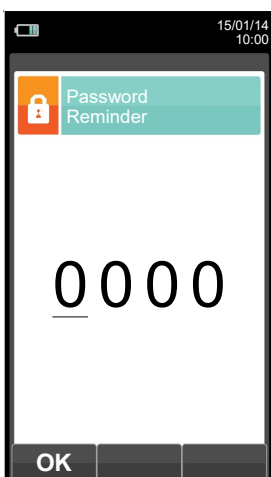

Enter the recalibration menu password 1111.

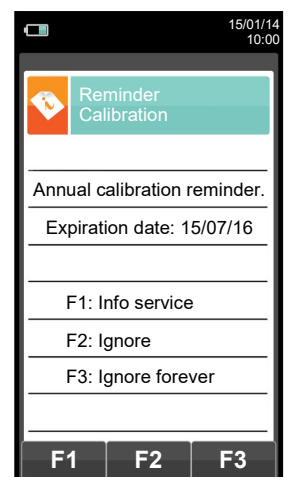
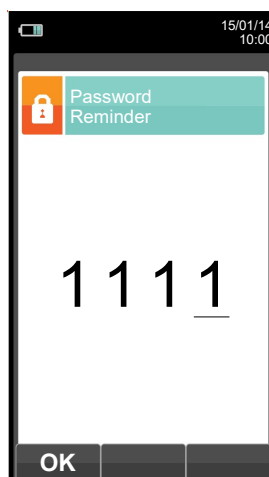

10.6.5 Configuration→Information→Probe

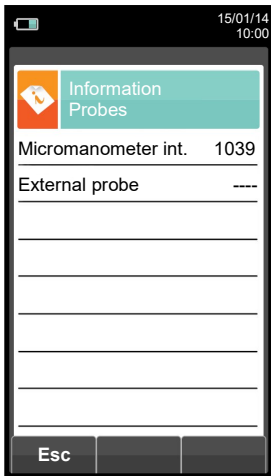

KEY	FUNCTION
	Activate the context keys shown on the display.
	Returns to the previous screen.

CONTEXT KEY	FUNCTION
	Returns to the previous screen.

10.7 Configuration → Diagnostic



KEY	FUNCTION
	Activate the context keys shown on the display.
	Returns to the previous screen.

CONTEXT KEY	FUNCTION
	Selects the available parameters.
	Enters in the selected parameter setting.
	Selects the available parameters.

PARAMETER	DESCRIPTION
 Sensors	<p>Displays information on the state and calibration of the electrochemical sensors:</p> <ul style="list-style-type: none"> Ok No problem detected absent The sensor was not detected err data Memory data error of the sensor unknown It is necessary to update the FW of the device err pos The sensor has been installed in the wrong position err cal Calibration error (sensor not calibrated) err curr Currents outside the range err cfg Do not use this sensor as it has not been accepted on the screen "types of sensors". <p>Also, from this screen the user can access the identification data of the sensor: type, serial number, date of manufacture and calibration. There are also the measured currents; in this way it is possible to perform a quick diagnosis in the event of a malfunction. SEE SECTION 10.7.1.</p>
 Pump	<p>In this submenu the user can temporarily turn the gas suction pump on or off. Also, it is possible to view the actual flow rate of the pump in liters per minute. It will not be possible to turn off the pump during an autozero cycle. SEE SECTION 10.7.2.</p>
 On site cal.	<p>It is possible to make a recalibration of the instrument's gas sensors with suitable known concentration gas cylinders. For the sensors which are sensitive to other gases, called interfering gases (for example NH₃, H₂, H₂S, SO₂, ...), it is possible to perform the on-site calibration also for the related interfering gas. The sensor recalibration procedure is protected by password: ask Seitron Assistance center. SEE SECTION 10.7.3.</p>
 Gas probe	<p>Tests the tightness of the gas probe pneumatic path. SEE SECTION 10.7.4.</p>
 Hardware	<p>At instrument turn on the firmware performs a full check on the physical efficiency of all types of HW memories installed on the instrument, as well as on the integrity of the data stored into them. Any issue is displayed in the screen 'Memories Diagnostics'. Should this happen it is advisable to turn the instrument off and then on again. In case the problem is permanent or frequently recurring, the user should contact the Service Center reporting the error code shown by the instrument. SEE SECTION 10.7.5.</p>

10.7.1 Configuration → Diagnostic → Sensors

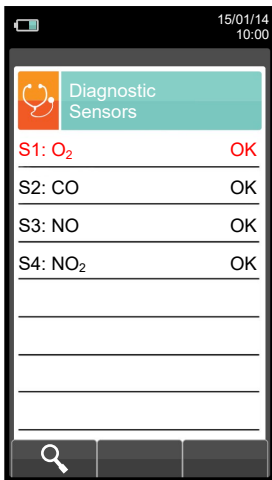

KEY	FUNCTION
	Activate the context keys shown on the display.
	Selects the fuel.
	Activates the context keys located in the left side of the display.
	Returns to the previous screen.

CONTEXT KEY	FUNCTION
	Displays the details of the selected sensor (see example below).
	Returns to the previous screen.

Example:



10.7.2 Configuration → Diagnostic → Pump

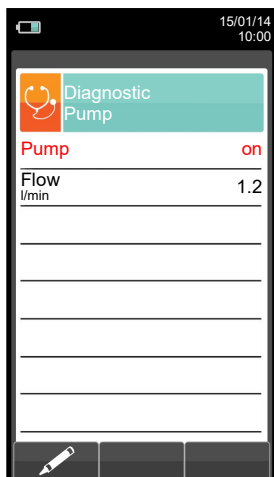

KEY	FUNCTION
	Activate the context keys shown on the display.
	In edit mode, cycling between on and off.
	Enters edit mode of the selected element and then confirms the change.
	Returns to the previous screen.

CONTEXT KEY	FUNCTION
	Enters edit mode: it is possible to turn the gas suction pump on and off.
	Confirms the modification.

10.7.3 Configuration → Diagnostic → On site cal.

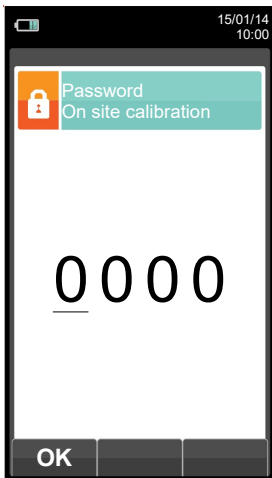
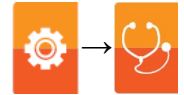

KEY	FUNCTION
	Activate the context keys shown on the display.
	Sets the password.
	Selects line; the selected line is displayed in red. In modification sets the value or the desired mode.
	Activates the context key located in the left side of the display.
	Returns to the previous screen. When in modify mode cancels the modification just made.

CONTEXT KEY	FUNCTION
	Once password is entered, gives access to the 'On site calibration' menu.
	Shows details for the selected sensor.
	Zeroes the timer.
	Enters the modification mode for the selected parameter.

10.7.4 Calibration procedure

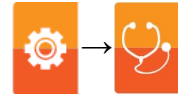

In order to perform the calibration, the following tools are needed:

- Test gas cylinder with certified gas concentration suitable for the concerned sensor, equipped with a pressure regulator.

WARNING!

For the oxygen sensor on site calibration, the zero value calibration must be carried out with nitrogen or any other gas mixture which DOES NOT contain oxygen.

- Flow meter.
- Hose with ' T ' shaped junction, in order to connect the cylinder to the instrument and the flow meter.

Following, the suggested stabilization times for the sensors on-site calibration.

O ₂ sensor:	from 3 to 5 minutes
CO sensor:	from 3 to 5 minutes
NO sensor:	from 3 to 5 minutes
SO ₂ sensor:	from 5 to 8 minutes
NO ₂ sensor:	from 5 to 8 minutes
C _x H _y sensor:	from 3 to 5 minutes
H ₂ S sensor:	from 3 to 5 minutes
CO ₂ sensor:	from 3 to 5 minutes
NH ₃ sensor:	from 3 to 5 minutes
H ₂ sensor:	from 3 to 5 minutes

1. Start the instrument

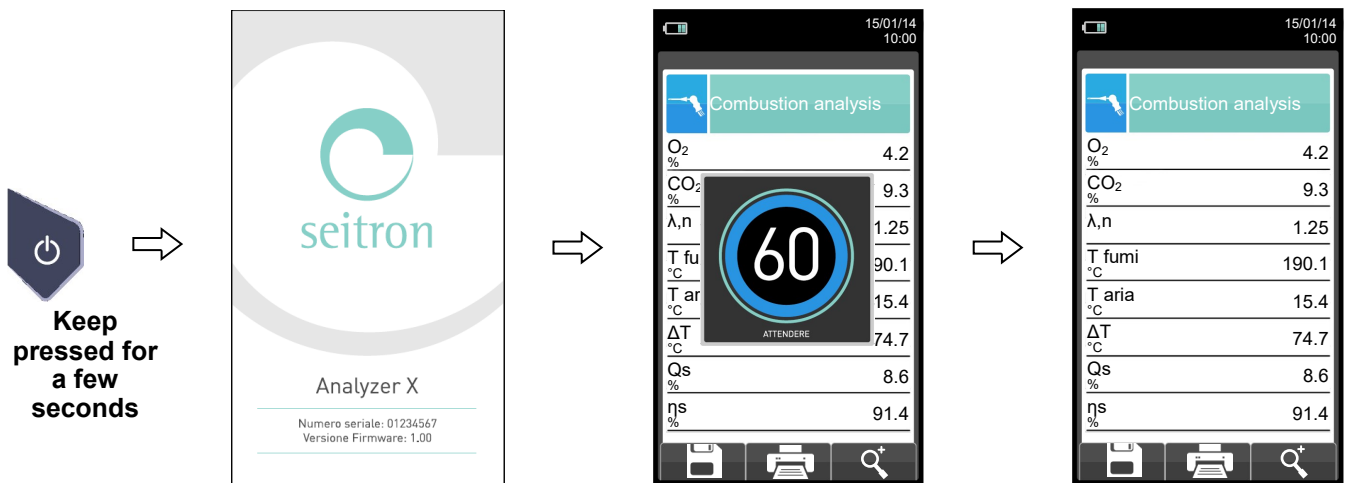

WARNING

- Make sure autozero is execute in clean air and terminates correctly.
- Do not connect the gas probe to the instrument.
- Check the battery charge level or connect the power adapter to avoid data loss during recalibration.

2. Once autozero is completed press the key and select the diagnostic icon.

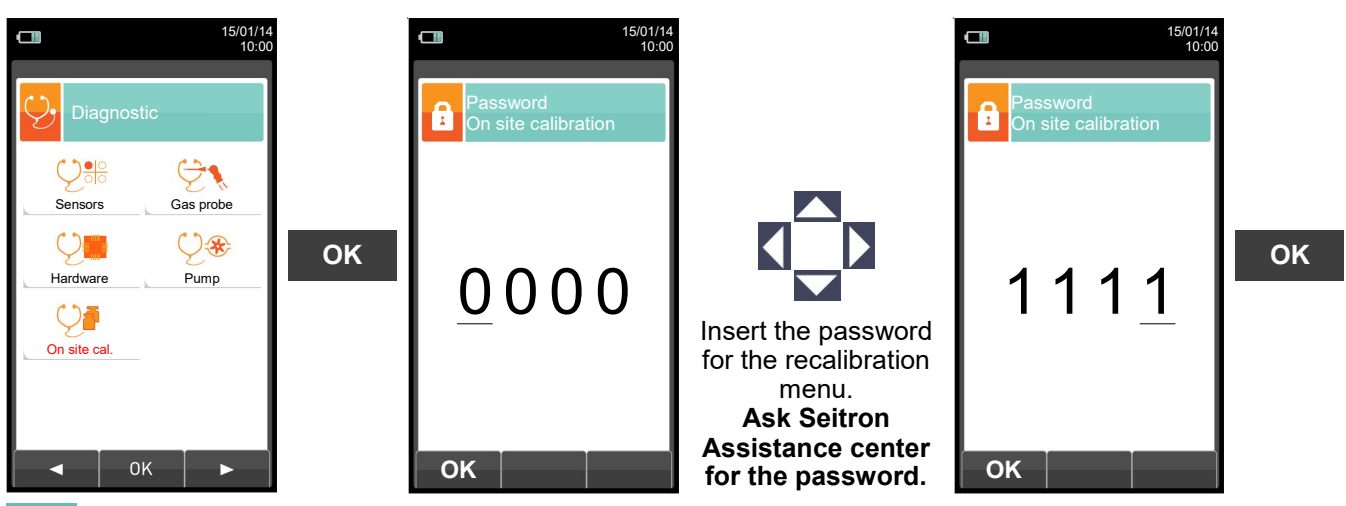



3. Once in the 'On site calibration' menu, is shown the list of the installed sensors for which the recalibration is available.

By selecting a sensor, on the recalibration screen are shown all the information related to the latest calibration.

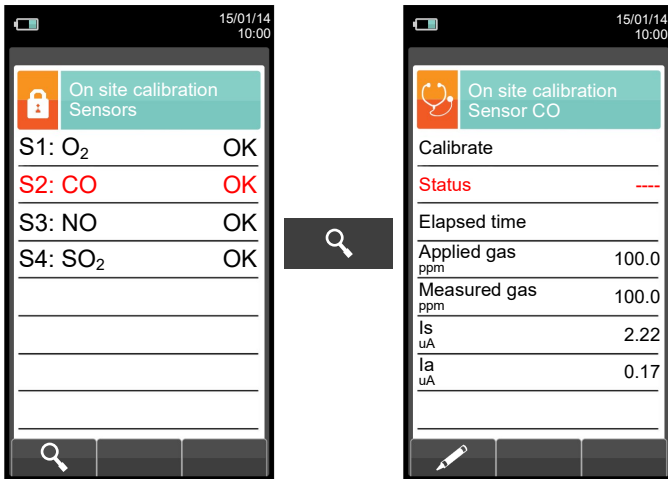

- Calibrate:** saves new calibration
- Status:** not active: returns to the factory calibration
active: returns to the last calibration made by the user
----: no 'on site calibration' has been previously stored
- Elapsed time:** timer
- Applied gas:** enters the concentration of the applied calibration gas
- Measured gas:** measures the concentration of the applied gas
- Is:** 'Is' current from the sensor
- Ia:** 'Ia' current from the sensor (available only on the CO sensor calibration)

CHOOSE THE SENSOR TO BE CALIBRATED AND DO AS FOLLOWS

4. Connect the known concentration gas cylinder to the instrument as shown in the following diagram:



WARNING!
Adequate ventilation must be provided when working with toxic gases, particularly the flow meter and instrument outputs must be evacuated by a ventilation system.

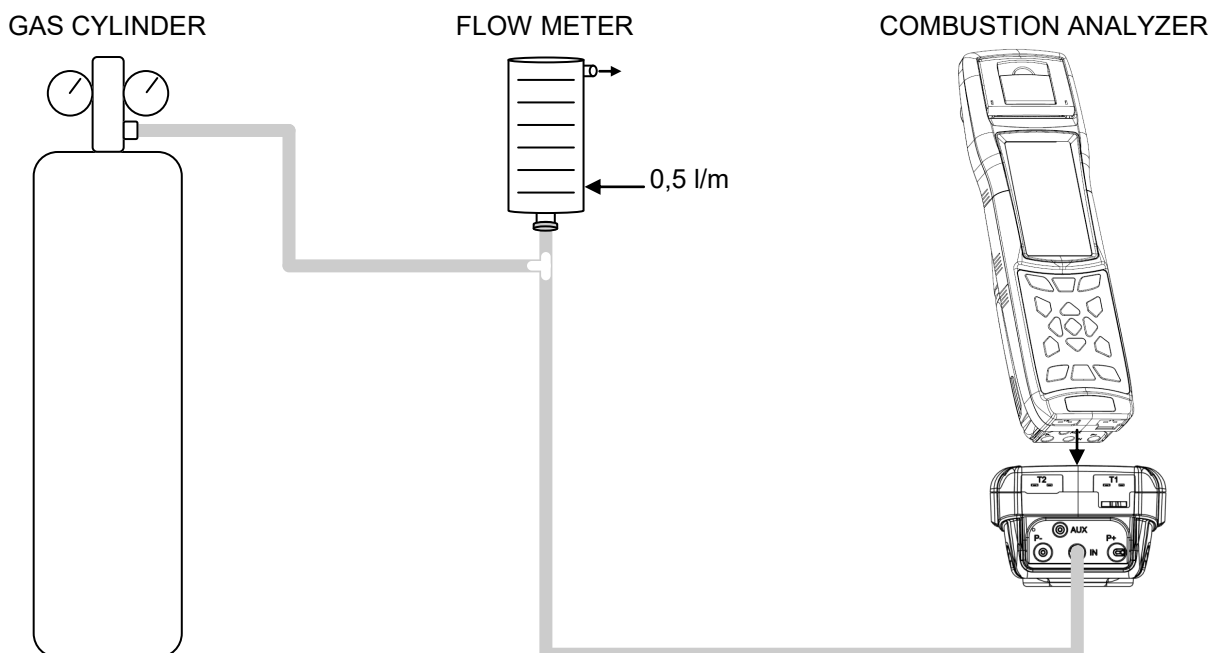

OXIGEN SENSOR (O₂) CALIBRATION DETAIL



- The calibration is **possible** only when the status is set to '----' (sensors that have never been calibrated before) otherwise it is necessary to set the status on 'non active' (see example below).

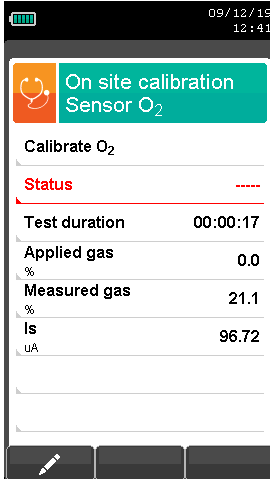

OR

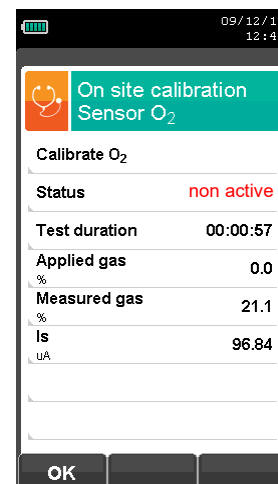
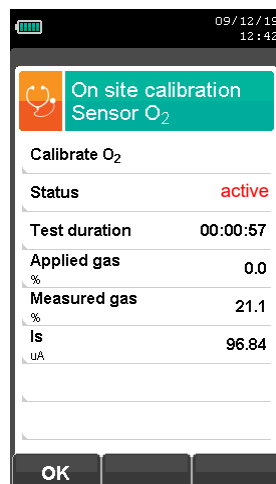
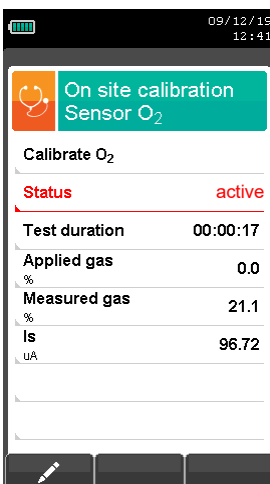

- Apply gas to the instrument** and adjust the output pressure of the gas from the cylinder so that the flow meter indicates a minimum flow of 0.5 l/m: this guarantees that the instrument is taking the exact amount of gas required by the internal pump.
- The instrument measures the concentration of gas applied; **wait at least 3 minutes to allow the reading to stabilize.** The reading is shown in line 'Gas measured'.

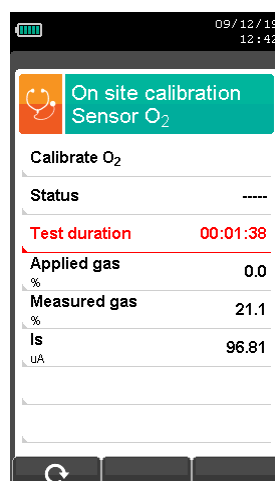
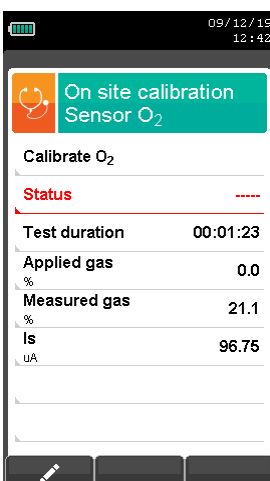

Zeroes the timer - helps to keep under control the time elapsing during the stabilization phase.

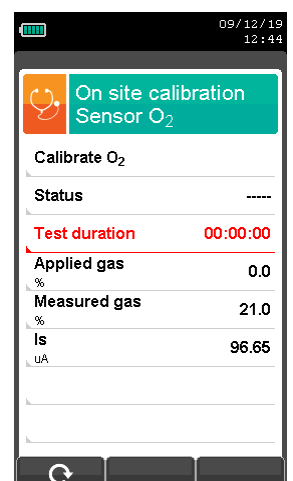



- When the stabilization time is over, select the row 'Calibrate' and store the new calibration.

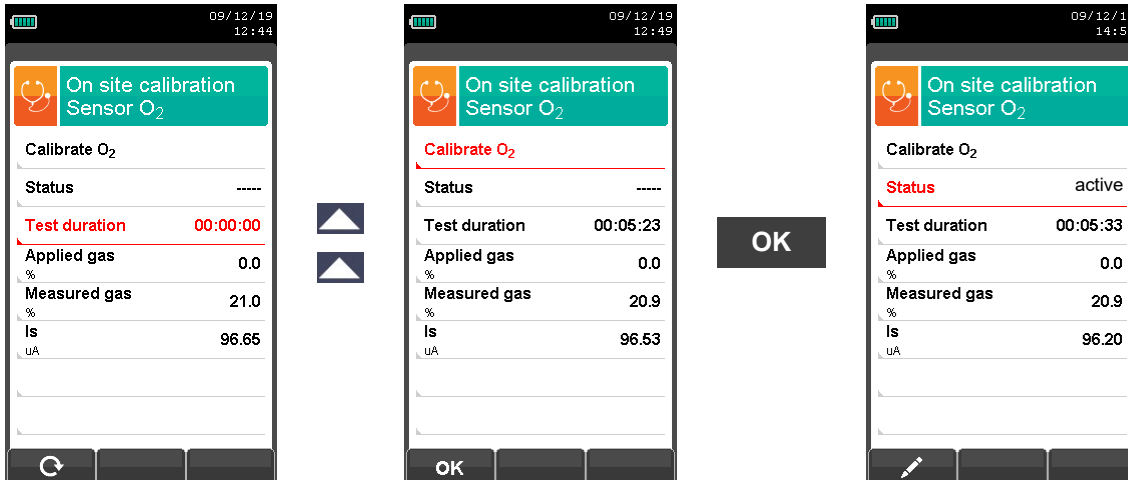

Messages in the 'Status' line:

saving: the instrument is saving the performed calibration

error: the sensor has NOT been recalibrated for any of the following reasons:

- The calibration gas cannot properly reach the instrument.
- Concentration for the calibration gas has not been set in the relevant line 'Applied gas'.
- The user didn't allow for the stabilization time to properly elapse.
- The sensor could be damaged or exhausted and must therefore be replaced.



WARNING

- At any time the user can restore the factory calibration in the instrument by setting the 'Status' line on 'not active'.
- The advised stabilization time for the on-site calibration of the sensors, is 3 minutes. For NO2 and SO2 sensors this time can be up to 5 minutes.

SENSOR CALIBRATION DETAIL FOR TOXIC GASES (EXAMPLE REFERRED TO CO).

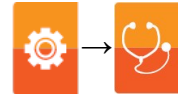

- The calibration is **possible** only when the status is set to '----' (sensors that have never been calibrated before) otherwise it is necessary to set the status on 'non active' (see example below).

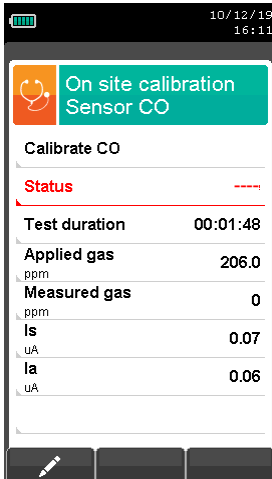

OR

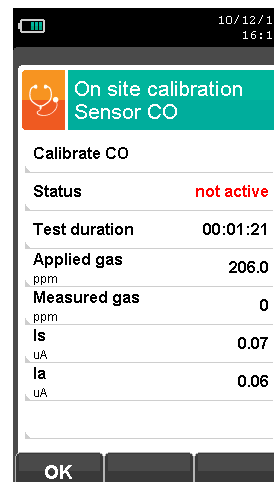
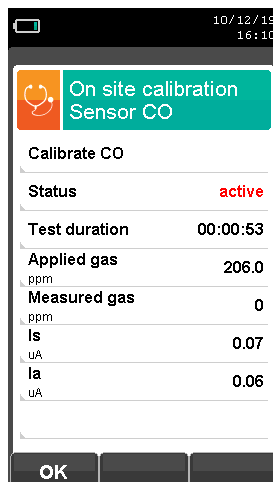
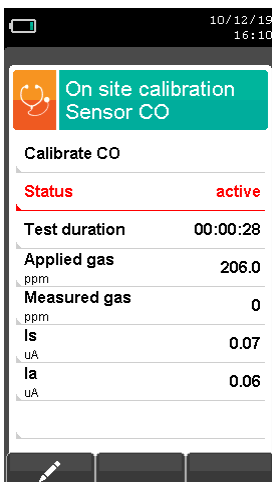

- Enter the value of the concentration of the gas applied.

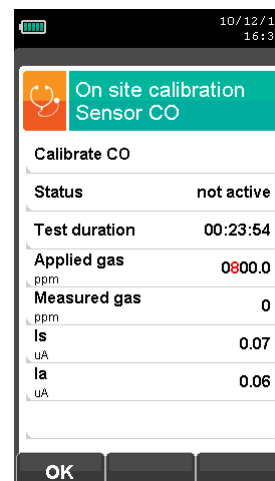
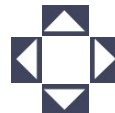
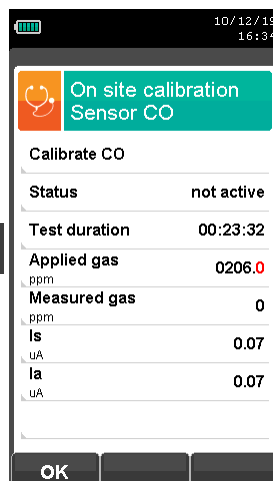
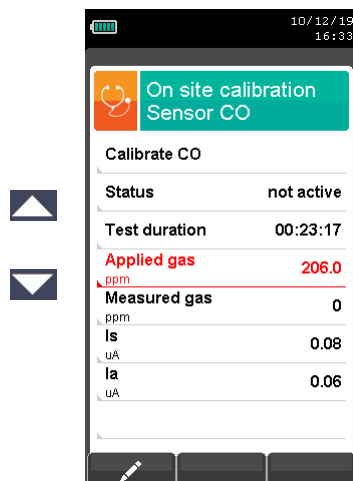

- Apply gas to the instrument and adjust the output pressure of the gas from the cylinder so that the flow meter indicates a minimum flow of 0.5 l/m: this guarantees that the instrument is taking the exact amount of gas required by the internal pump.

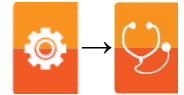

- The instrument measures the concentration of gas applied; **wait at least 3 minutes to allow the reading to stabilize**. The reading is shown in line 'Gas measured'.



 Zeroes the timer - helps to keep under control the time elapsing during the stabilization phase.

- When the stabilization time is over, select the row 'Calibrate' and store the new calibration.



Messages in the 'Status' line:

- saving:** the instrument is saving the performed calibration
- error:** the sensor has NOT been recalibrated for any of the following reasons:
- The calibration gas cannot properly reach the instrument.
 - Concentration for the calibration gas has not been set in the relevant line 'Applied gas'.
 - The user didn't allow for the stabilization time to properly elapse.
 - The sensor could be damaged or exhausted and must therefore be replaced.



WARNING

- At any time the user can restore the factory calibration in the instrument by setting the 'Status' line on 'not active'.
- The stabilization time advised for the on site calibration of the sensors, is 3 minutes. For the NO₂ and SO₂ sensors this stabilization time could reach 5 minutes.

SENSOR CALIBRATION DETAIL FOR TOXIC GASES WITH INTERFERING GASES

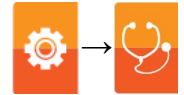

The sensors for toxic gases with interfering gases are those sensors which are sensible to other gases. The on-site calibration for these sensors allows to calibrate also the interfering gases.

The on-site calibration procedure for these sensors is the same described on the previous pages regarding the toxic gases and can be performed for all the interfering gases of the sensor itself.

The following procedure is for accessing the interfering gases of the sensor that must be recalibrated on-site (example referred to the SO₂ sensor).

Not significant value

SENSOR	INTERFERING GASES		
NH ₃	H ₂ S	SO ₂	NO
SO ₂	CO	NO	NO ₂
H ₂ S	SO ₂	NO	NO ₂
H ₂	CO	NO	NO ₂

Tab. 1: Interfering gases table.

WARNING
The recommended stabilization time for the on-site calibration of these sensors is 5 minutes.

WARNING
During analysis, the influence of interfering gases is compensated only if the correspondent sensor is installed.

10.7.5 Configuration → Diagnostic → Gas probe

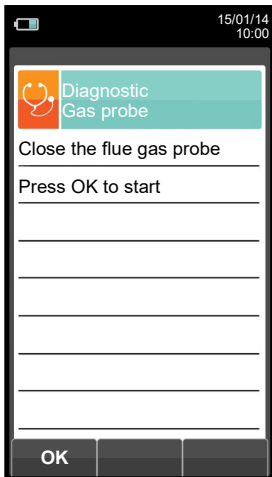
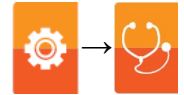

Connect the flue gas sampling probe and filter unit assembly to the instrument;
Fully insert the black rubber cap on the gas probe tip, as shown in the following picture:

KEY	FUNCTION
	Activate the context keys shown on the display.
	Activates the context key located in the left side of the display.
	Returns to the previous screen.

CONTEXT KEY	FUNCTION
	Starts the test to check the tightness of the gas sampling probe.
	Starts the test of the gas sampling probe.

Tightness test of the probe.

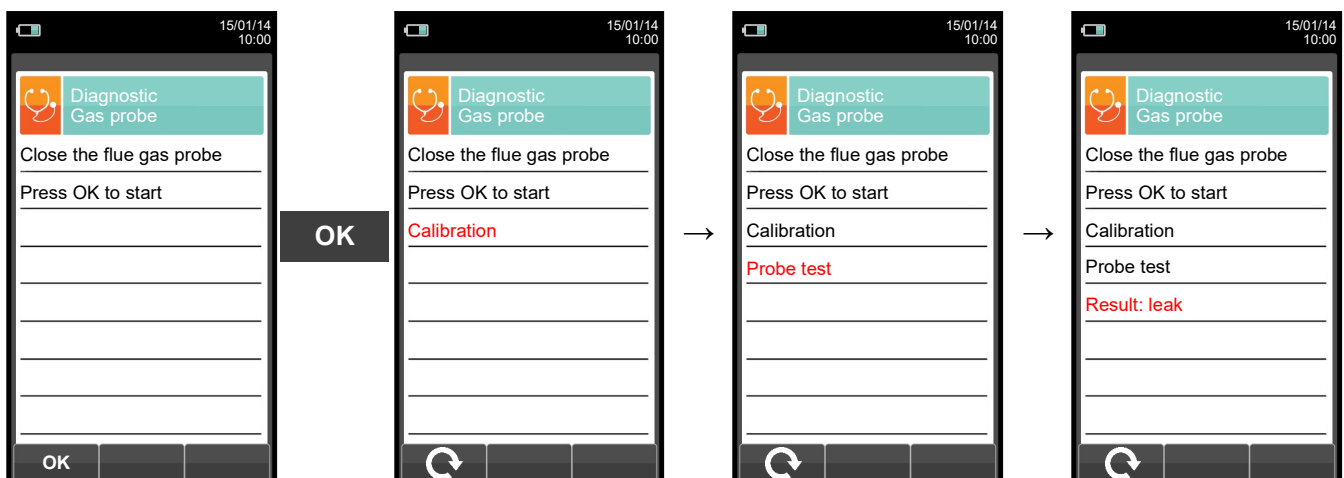

Results:

Tightness: The system is OK

Error: Make sure that the probe is connected to the input P-, check the seals of the pneumatic connections and/or the seal of the condensation trap and check that the test cap is correctly inserted on the tip of the probe. **WARNING: a damaged probe tip may impair the test.**

10.7.6 Configuration → Diagnostic → Hardware

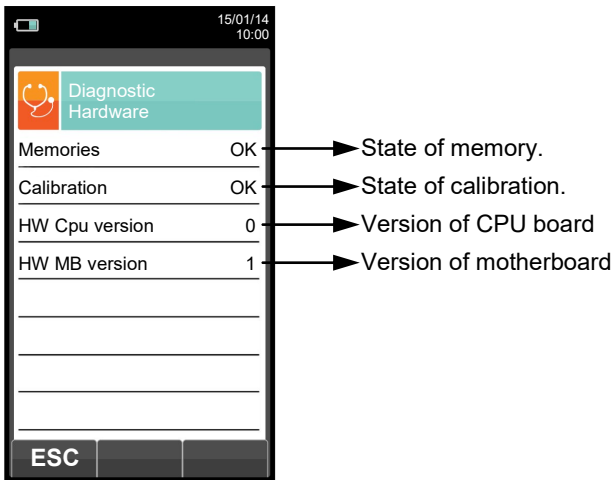

KEY	FUNCTION
	Activate the context keys shown on the display.
	Returns to the previous screen.

CONTEXT KEY	FUNCTION
	Returns to the previous screen.

10.8 Configuration→Language

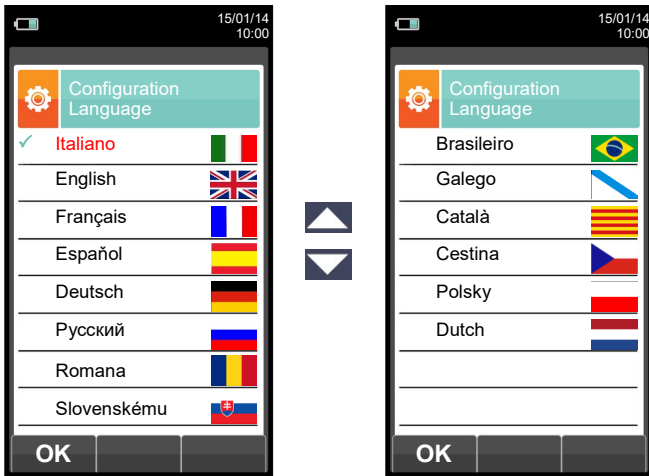

KEY	FUNCTION
	Activate the context keys shown on the display.
	Scrolls through the available languages.
	Sets the selected language.
	Returns to the previous screen.

CONTEXT KEY	FUNCTION
	Sets the selected language.



10.9 Configuration→Restore

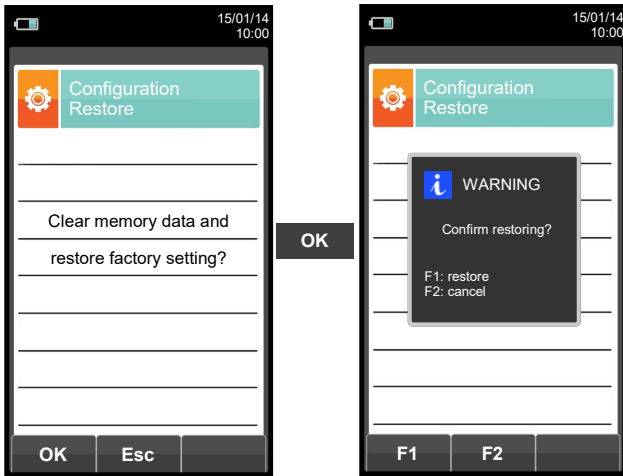

KEY	FUNCTION
	Activate the context keys shown on the display.
	Starts the factory data reset phase.
	Exits the current screen without resetting.

CONTEXT KEY	FUNCTION
	Starts the factory data reset phase.
	Exits the current screen without resetting.
	Factory reset.
	Cancels the factory data reset phase and goes back to the previous screen.

11.1 Memory Menu

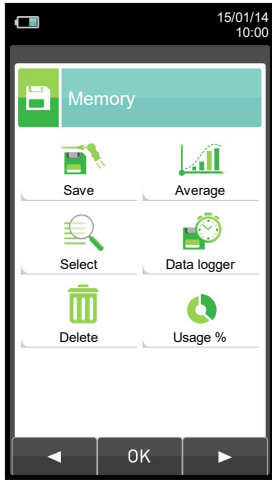



KEY	FUNCTION
	Activate the context keys shown on the display.
	Returns to the previous screen.

CONTEXT KEY	FUNCTION
	Selects the available parameters.
	Enters in the selected parameter setting.
	Selects the available parameters.

PARAMETER	DESCRIPTION
Save	From this screen the user can start the combustion analysis. The data shown summarizes the mode of analysis and the selected memory. SEE SECTION 11.2.
Average	Allows the user to see the average of the analyses contained in the selected memory. SEE SECTION 11.3.
Select	<ul style="list-style-type: none"> - Allows the user to choose the memory position to be used to save the combustion analysis and/or the draft/pressure measurement. For each memory it is possible to enter the personal information of the customer (name of the customer, address, telephone number, type of boiler, etc.). - Allows the user to see and print the stored analyses, individually or as an average. The analyses can be found (via the context key "find") by memory location or by the date they were saved; it is also possible to see the draft, smoke and ambient CO. In the menu "Find Memory" the activation of the Print Memory is enabled only on the page where the analyses or the draft, smoke and ambient CO data are displayed. SEE SECTION 11.4.
Data logger	<p>This submenu allows the user to define the mode of analysis and of memory selection:</p> <p>Automatic analysis mode:</p> <p>data logger</p> <p>This mode is entirely configurable by the user (it is necessary to set the number of samples to be acquired, the duration of acquisition of each sample and the printing mode).</p> <p>When the combustion analysis starts, the device will automatically carry out and store the number of samples set, spaced from one another according to the set time.</p> <p>After the combustion analysis (indicated by a beep), if the "Manual Print" mode has been selected, the device will display the average of the samples taken with the possibility to recall them individually; the user can then print them (total, complete, ...).</p> <p>On the contrary, if the user has selected the option "Automatic Print", the device will automatically proceed to print the analyses, according to the current printing settings, without displaying the average.</p>



 <p>Data logger</p>	<p>Warning: in automatic mode, the measurements of smoke, draft and ambient CO must be taken before starting the combustion analysis.</p> <p>Manual analysis mode If the user chooses the manual mode, he will perform the combustion analysis manually; in this case, the settings regarding printing and duration of the automatic analysis will not be considered. At this point the user can start the manual analysis after waiting for the measured displayed to stabilize: then the user can proceed to save or directly print the data, which will be prepared in accordance with the previously configured settings. At the end of the three analyses, the screen with the average can be displayed, which also contains all the data necessary to fill in the booklet of the system or plant.</p> <p>Memory selection mode Manual: the memory will have to be selected manually via the parameter "Select" Auto: the memory, to which the measurements and combustion analyses will be saved, will be suggested automatically when the device is turned on. SEE SECTION 11.5.</p>
 <p>Delete</p>	<p>Allows the user to delete the contents of each memory or of the entire 99 memories. SEE SECTION 11.6.</p>
 <p>Usage %</p>	<p>The user, through this menu, can view the percentage of memory usage. SEE SECTION 11.7.</p>

11.1.1 Memory Organization

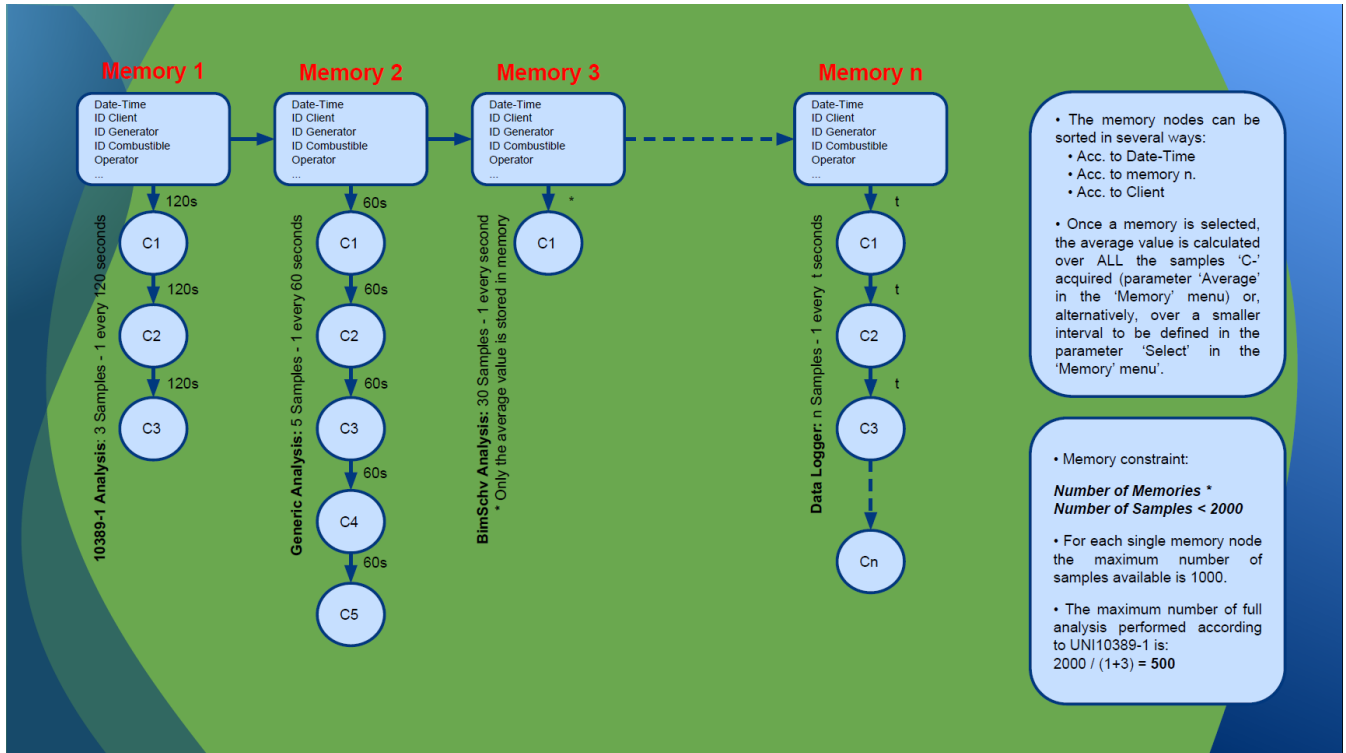

11.2 Memory Menu → Save

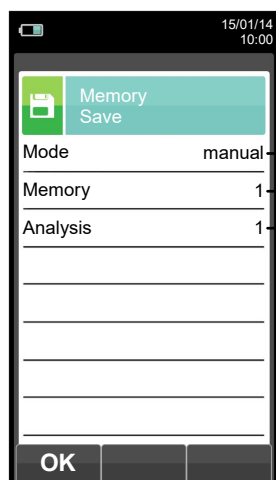

Manual analysis mode
 Number of selected memory
 Number of analyses carried out

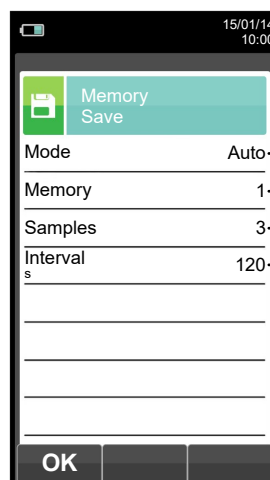

Automatic analysis mode
 Number of selected memory
 Number of samples to take
 Interval between samples

KEY	FUNCTION
	Activate the context keys shown on the display.
	Starts saving the combustion analysis according to the mode set in the parameter 'Data logger'.
	Returns to the previous screen.

CONTEXT KEY	FUNCTION
	Starts saving the combustion analysis according to the mode set in the parameter 'Data logger'.
	Deletes the contents of the selected memory. (Visible when the selected memory contains previous analyses).
	Cancels the deletion of the contents of the selected memory. (Visible when the selected memory contains previous analyses).



Example 1: Saving the combustion analysis in manual mode

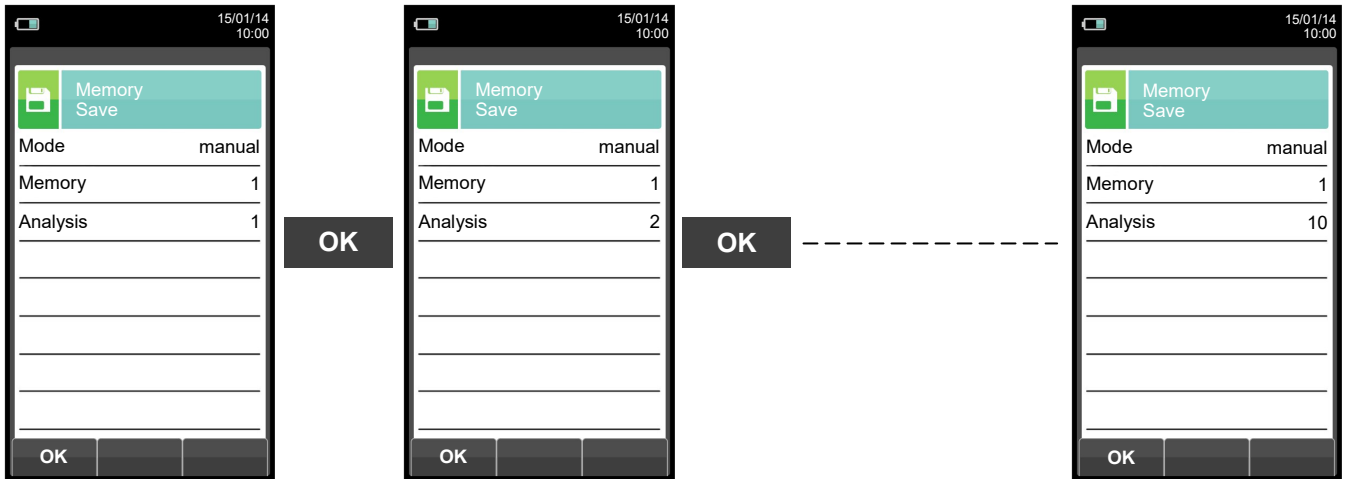

Example 2: Saving the combustion analysis in automatic mode (example auto)

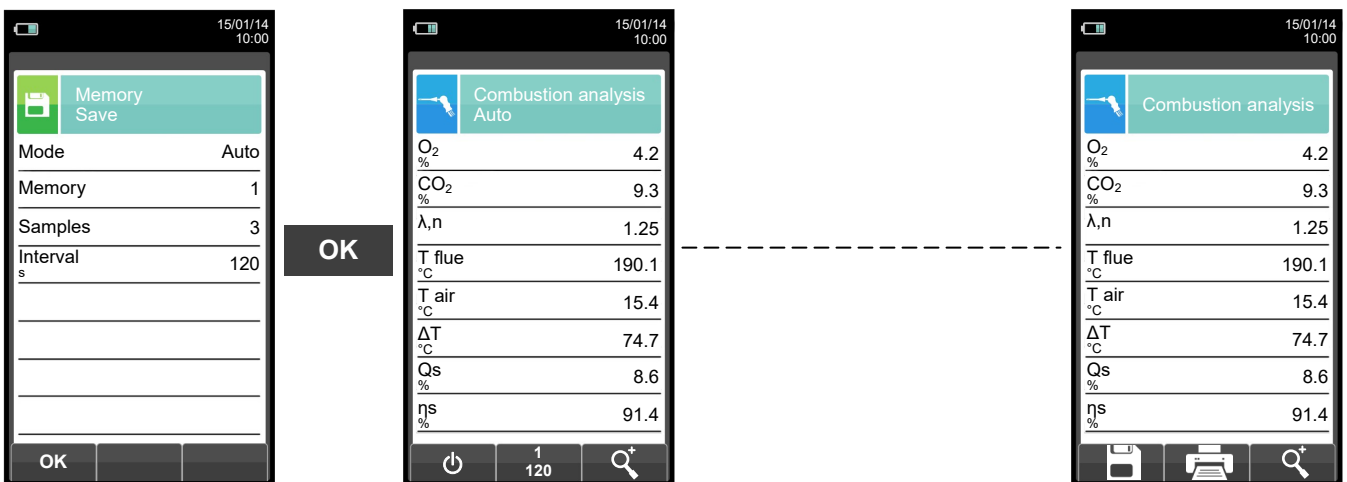

FOR ANY FURTHER INFORMATION SEE [CHAPTER 14 'FLUE GAS ANALYSIS'](#).

11.3 Memory Menu → Average

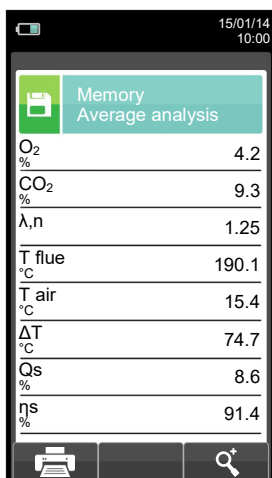

KEY	FUNCTION
	Activate the context keys shown on the display.
	Scrolls through the values of the average analysis.
	Activates the context key located in the left side of the display.
	Returns to the previous screen without saving the changes made.

CONTEXT KEY	FUNCTION
	Zoom. By pressing this interactive key repeatedly, the device displays the following sequence: AAA → AAA → AAA → AAA
	Starts printing the paper print-out. SEE SECTION 12.



11.4 Memory Menu → Select

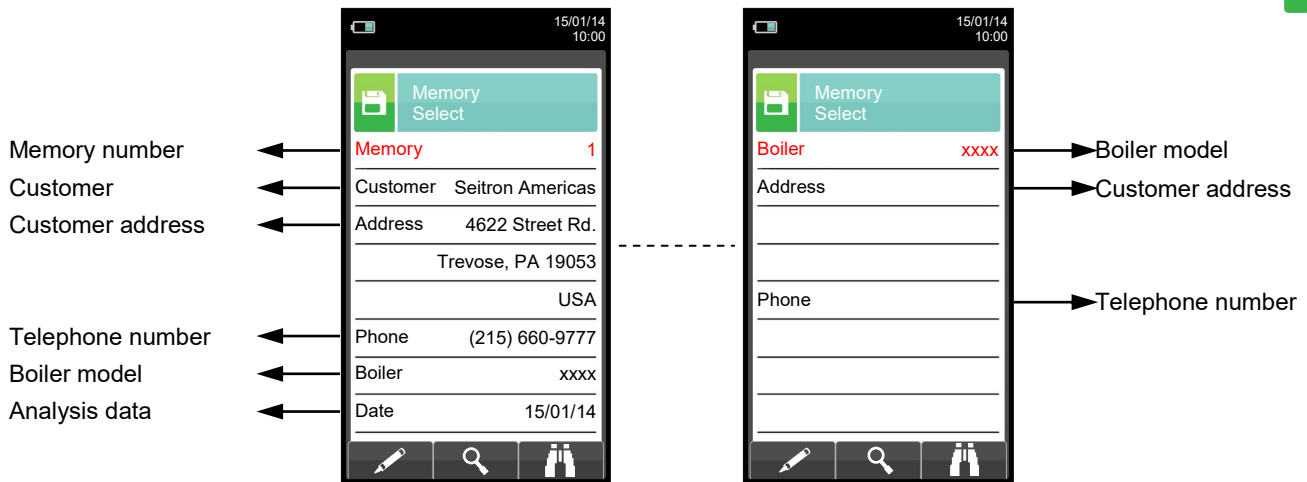

KEY	FUNCTION
	Activate the context keys shown on the display.
	In "edit text"/"search for data"/"search for memory number": it moves the cursor on the box corresponding to the desired letter or number.
	Selects line; the selected line is displayed in red.
	Activates the context key located in the left side of the display.
	Returns to the previous screen without saving the changes made.

CONTEXT KEY	FUNCTION
	Enters the modification mode for the selected parameter. It is possible to select the number of the memory to use for the combustion analysis and/or to enter the information relative to the plant.
	Recall memory. By activating this function, the user has the possibility to view the data present in the selected memory. SEE SECTION 11.4.1.
	Search function. Thanks to this function, the user has the possibility to quickly search for a specific analysis. The search can be carried out considering the memory number (by selecting the parameter "Memory"), the customer (by selecting one of the following parameters: "Customer", "Address", "Telephone" or "Generator") or the date (by selecting the parameter "Date").
	Confirms the settings and, if the search function is enabled, it starts the research.
	In "Edit text" it confirms the input of the selected letter or number.
	In "Edit text" it cancels the letter or number that precedes the cursor.
	In "Edit text" it goes from uppercase to lowercase, to symbols, to special characters.
	Selects the memories within the range of the research carried out.
	Selects the memories within the range of the research carried out.



11.4.1 Memory Recall

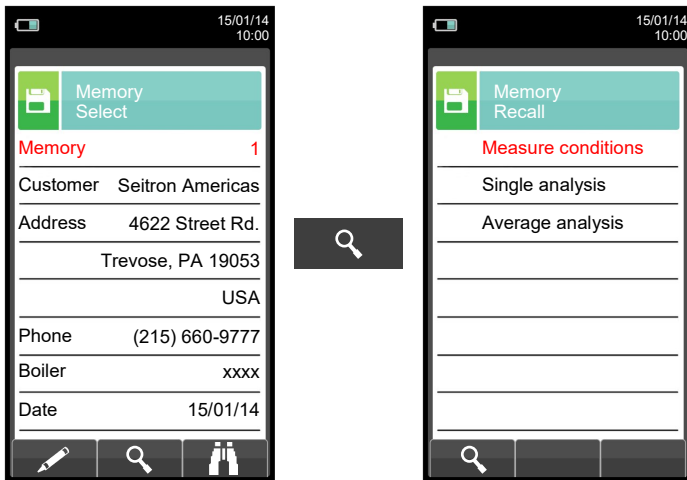

KEY	FUNCTION
	Activate the context keys shown on the display.
	Selects line; the selected line is displayed in red.
	Activates the context key located in the left side of the display.
	Returns to the previous screen.

CONTEXT KEY	FUNCTION
	Displays the details of the selected parameter.

1. Details of measurement conditions

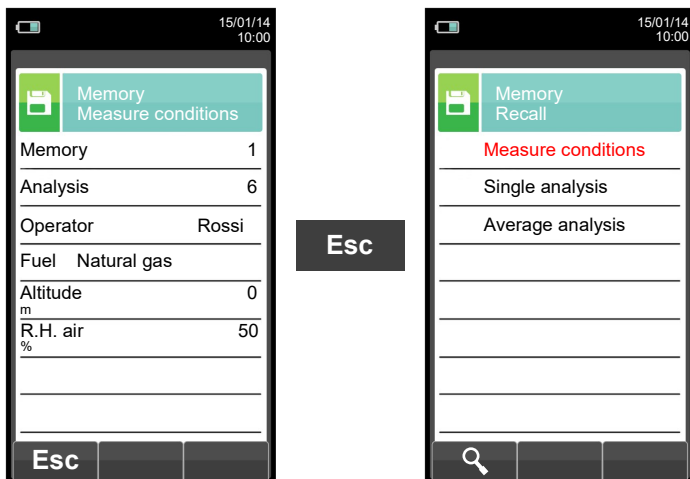

CONTEXT KEY	FUNCTION
	Returns to the previous screen.





2. Details of Single analysis

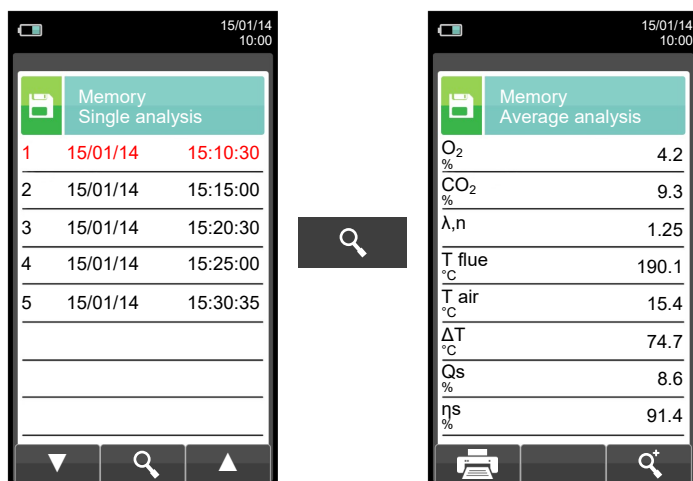

KEY	FUNCTION
	Activate the context keys shown on the display.
	Selects line; the selected line is displayed in red. In "view detail" the previous or next pages are shown.
	Views the details of the selected parameter.
	Returns to the previous screen.

CONTEXT KEY	FUNCTION
	Selects line; the selected line is displayed in red.
	Views the details of the selected parameter.
	Selects line; the selected line is red.
	Goes to next page.
	Goes to previous page.
	Starts printing the paper print-out. SEE SECTION 12.
	Zoom. By pressing this interactive key repeatedly, the device displays the following sequence: AAA → AAA → AAA → AAA



3. Average interval details

Defines the starting sample to define the analysis average.

Defines the end sample to define the analysis average.

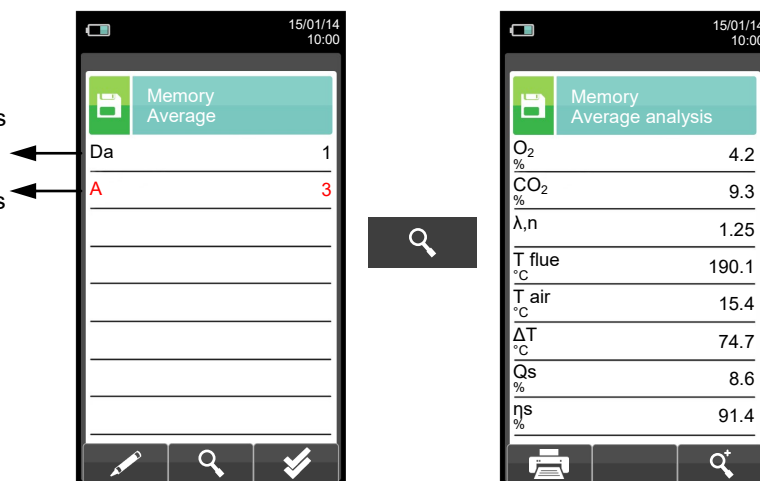

KEY	FUNCTION
	Activate the context keys shown on the display.
	In edit mode, it sets the number of the desired sample; the number to change is red.
	Selects line; the selected line is displayed in red.
	Activates the context key located in the left side of the display.
	Returns to the previous screen without saving the changes made.

CONTEXT KEY	FUNCTION
	Enters edit mode: it is possible to select the number of the sample to use to have the average of the analysis carried out.
	Shows the average analysis in the interval set.
	Zoom. By pressing this interactive key repeatedly, the device displays the following sequence: AAA → AAA → AAA → AAA
	Sets all the samples of the analyses carried out: From 1 (first sample) To xxx (last sample).
	Confirms the settings.
	Starts printing. SEE SECTION 12.

11.5 Memory Menu → Data logger

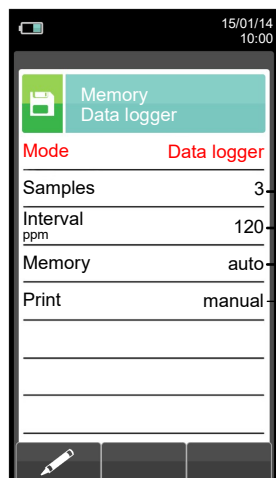

- The selectable analysis modes are: **Manual - Data logger**
- Number of samples to make (parameter not visible in manual analysis mode).
- Period of acquisition of each sample (parameter not visible in manual analysis mode).
- The memory selection modes are: **manual** or **auto**.
If "**auto**" mode has been selected, the research of the available memory will be performed automatically when the device is turned on).
- The selectable printing modes are: **manual** or **auto**.
If "**auto**" mode has been selected, the printing will be performed automatically at the end of the combustion analysis (parameter not visible in manual analysis mode).

KEY	FUNCTION
	Activate the context keys shown on the display.
	Selects line; the selected line is displayed in red.
	Activates the context key located in the left side of the display.
	Returns to the previous screen.

CONTEXT KEY	FUNCTION
	Enters the modification mode for the selected parameter.
	Confirms the settings.

11.6 Memory→Delete

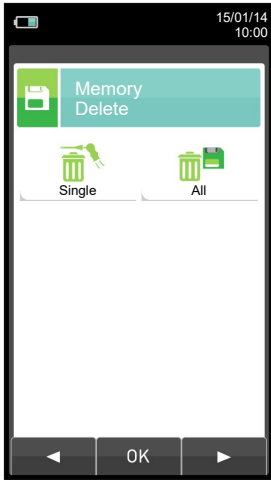

KEY	FUNCTION
	Activate the context keys shown on the display.
	Returns to the previous screen.

CONTEXT KEY	FUNCTION
	Selects the available parameters.
	Enters in the selected parameter setting.
	Selects the available parameters.

PARAMETER	DESCRIPTION
 Single	This option allows the user to delete the contents of each individual memory; to do this, the user will have to confirm the operation so as to avoid losing previously saved data. SEE SECTION 11.6.1.
 All	This option allows the user to delete the contents of the 99 memories; to do this, the user will have to confirm the operation so as to avoid losing previously saved data. SEE SECTION 11.6.2.



11.6.1 Memory→Delete→Single

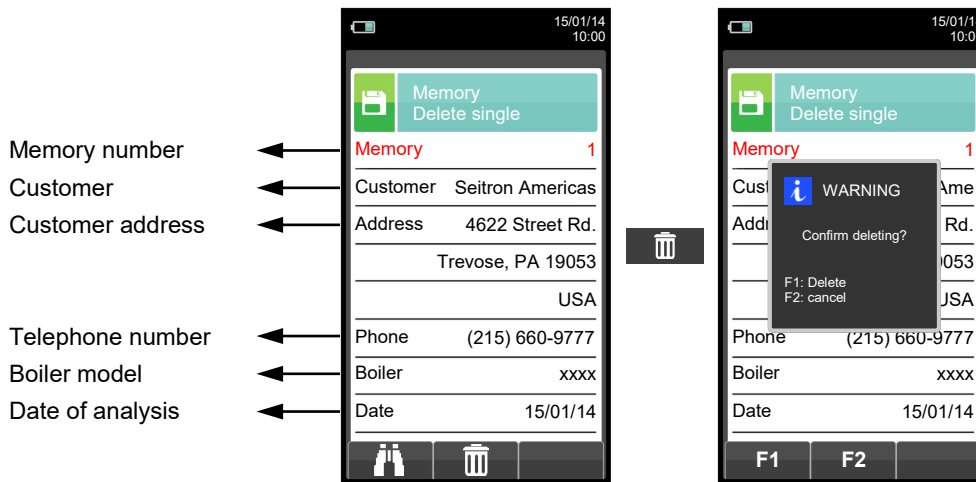

Memory number
 Customer
 Customer address

 Telephone number
 Boiler model
 Date of analysis

KEY	FUNCTION
	Activate the context keys shown on the display.
	In "edit text"/"search for data"/"search for memory number": it moves the cursor on the box corresponding to the desired letter or number.
	Selects line; the selected line is displayed in red.
	Activates the context key located in the left side of the display. In "edit text": Confirms text input.
	Returns to the previous screen.

CONTEXT KEY	FUNCTION
	Search function. Thanks to this function, the user has the possibility to quickly search for a specific analysis. The search can be carried out considering the memory number (by selecting the parameter "Memory"), the customer (by selecting one of the following parameters: "Customer", "Address", "Telephone" or "Generator") or the date (by selecting the parameter "Date").
	Confirms the settings and, if the search function is enabled, it starts the research.
	In "Edit text" it confirms the input of the selected letter or number.
	In "Edit text" it cancels the letter or number that precedes the cursor.
	In "Edit text" it goes from uppercase to lowercase, to symbols, to special characters.
	Selects the memories within the range of the research carried out.
	Selects the memories within the range of the research carried out.
	Starts deleting the selected memory.
	Deletes the selected memory.
	Cancel the deleting and goes back to the previous page.



11.6.2 Memory→Delete→All

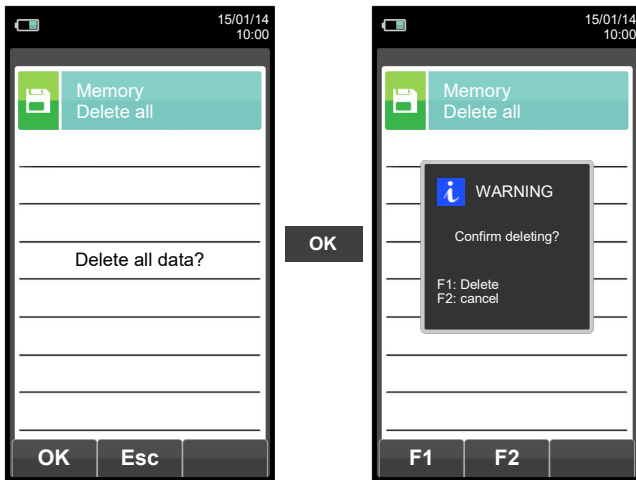

KEY	FUNCTION
	Activate the context keys shown on the display.
	Start erasing all memories.
	Returns to the previous screen.

CONTEXT KEY	FUNCTION
	Start erasing all memories.
	Returns to the previous screen.
	Deletes all memories.
	Cancel the deleting and returns to the previous page.

11.7 Memory→Usage %

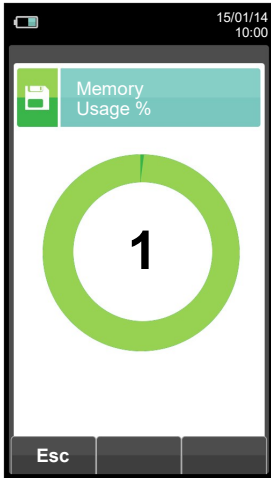

KEY	FUNCTION
	Activate the context keys shown on the display.
	Returns to the previous screen.

CONTEXT KEY	FUNCTION
	Returns to the previous screen.

12.1 Print Menu

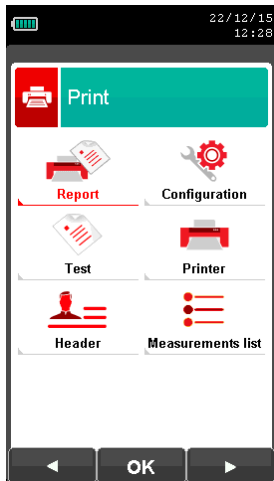

KEY	FUNCTION
	Activate the context keys shown on the display.
	Returns to the previous screen.

CONTEXT KEY	FUNCTION
	Selects the available parameters.
	Enters in the selected parameter setting.
	Selects the available parameters.

PARAMETER	DESCRIPTION
Report	Enables the Print Menu. A hard copy of the complete combustion analysis can be printed. The printed values are those shown on the display when the menu is enabled. This menu can be used for combustion analysis, even when recalled from the memory, for draft, smoke, ambient gas and for tightness test results. SEE SECTION 12.2.
Configuration	The user, by means of this menu, can configure the test report format: Copies: Allows to set the number of printed copies and layout of the paper print-out. Several copies of the test paper print-out can be printed, choosing among different layouts according to the information included. Report: The paper print-out layout selection is only valid for combustion analysis and can be chosen among Complete, Partial and Total. Paper print-outs for draft, smoke, ambient gas concentration and tightness test only allow a specific layout. Layouts options for combustion analysis are specified as described in the following: Full: includes a header with company data as well operator data previously programmed in the configuration menu, measurements sampled in the combustion analysis and, when sampled, the draft, smoke and CO ambient gas values. Partial: only reports the combustion analysis measurement values and information, without any header, comments or blank lines for operator comments. Total: prints full print-out of average values with individual test data. Date/Time: It allows you to define whether or not to print the date and time at which the combustion analysis was performed. Manual: The date and time are not printed in the header of the analysis report . It is the responsibility of the operator to enter the data manually . Auto: The date and time are printed in the header of the analysis report. SEE SECTION 12.3.
Test	Print: Prints a graphical/alphanumeric test paper print-out for a complete check of the printer operation. Paper feed: Feeds paper in the printer; this function is most useful when replacing the paper roll in the printer. SEE SECTION 12.4.
Printer	Selects the printer type: internal or Bluetooth. When Bluetooth printer is selected a pairing procedure will be needed in order to match the printer to the instrument. The pairing procedure has to be performed only once. SEE SECTION 12.5.
Header	Allows the user to enter, in six lines of 24 characters each the name of the Company or owner of the device or the information regarding the latter (e.g. address, telephone number), which will be printed in the header of the analysis report. SEE SECTION 12.6.
Measurements list	In this submenu the user has the possibility to view the list of measurements that the device performs. With the interactive keys, the user can add, delete or move a selected measurement. SEE SECTION 12.7.



12.2 Print→Report

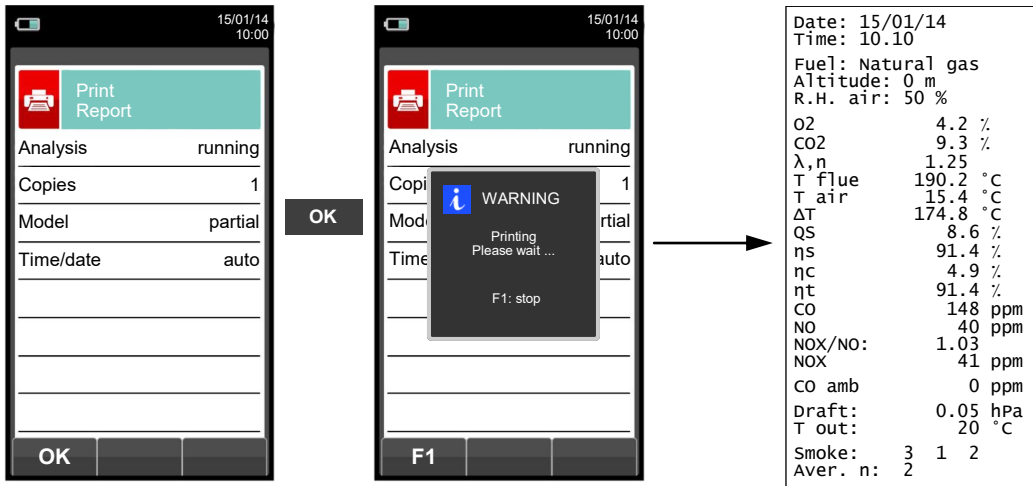

KEY	FUNCTION
	Activate the context keys shown on the display.
	Returns to the previous screen.

CONTEXT KEY	FUNCTION
	Starts printing the paper print-out.
	Stops printing the paper print-out.



12.3 Print→Configuration

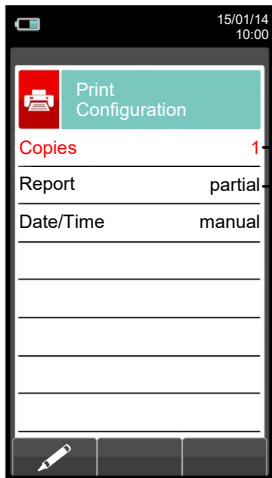

- Set the number of copies to print: 1 .. 5.
- The paper print-out models that can be selected are: **partial - full - total**
- Set between: **Manual:** date and time are not printed on the analysis report.
Auto: date and time are printed automatically on the analysis report.

KEY	FUNCTION
	Activate the context keys shown on the display.
	Selects line; the selected line is displayed in red. In modification sets the value or the desired mode.
	Activates the context key located in the left side of the display.
	Returns to the previous screen. When in modify mode cancels the modification just made.

CONTEXT KEY	FUNCTION
	Enters the modification mode for the selected parameter.
OK	Confirms the settings.

Example:

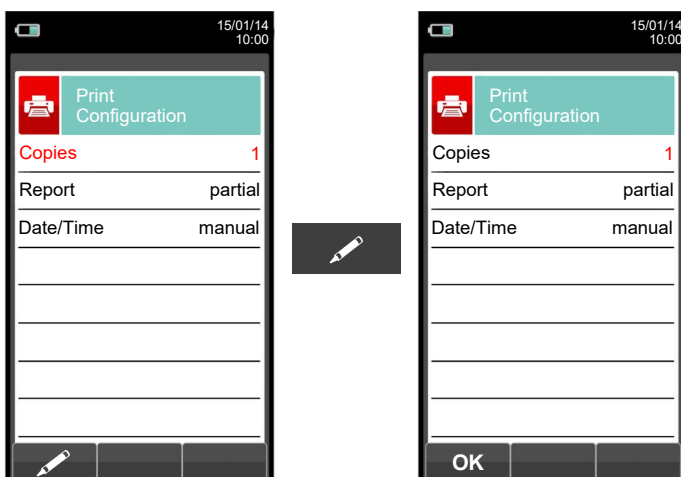



12.4 Print→Test

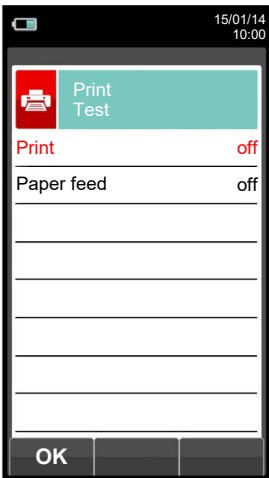

KEY	FUNCTION
	Activate the context keys shown on the display.
	Selects line; the selected line is displayed in red. In modification sets the value or the desired mode.
	Activates the context key located in the left side of the display.
	Returns to the previous screen. When in modify mode cancels the modification just made.

CONTEXT KEY	FUNCTION
	Confirms the settings.

Example:

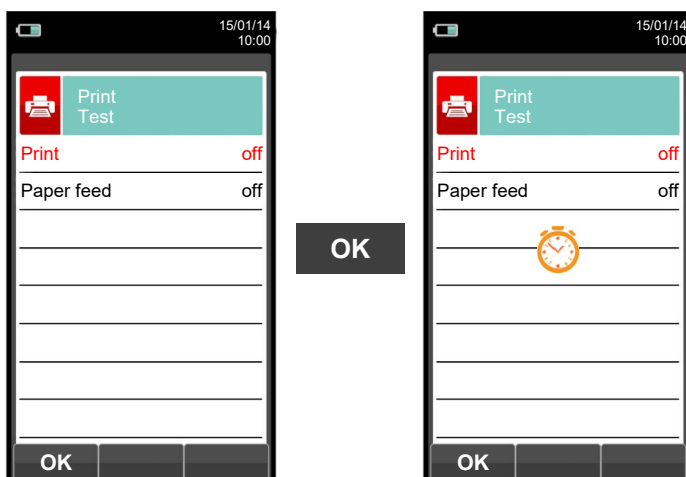



12.5 Print→Printer

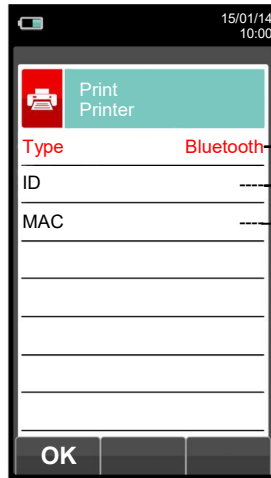
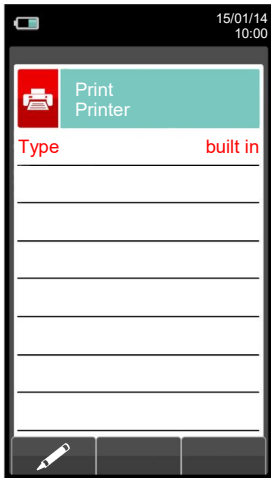

- Printer type: **built in (internal) - Bluetooth (external)**.
- Name of the Bluetooth printer associated with the instrument.
- Address of the Bluetooth printer associated with the instrument.

KEY	FUNCTION
	Activate the context keys shown on the display.
	Selects line; the selected line is displayed in red. In modification sets the value or the desired mode.
	Activates the context key located in the left side of the display.
	Returns to the previous screen. When in modify mode cancels the modification just made.

CONTEXT KEY	FUNCTION
	Enters the modification mode for the selected parameter.
	Confirms the settings.

12.5.1 Print→Pairing

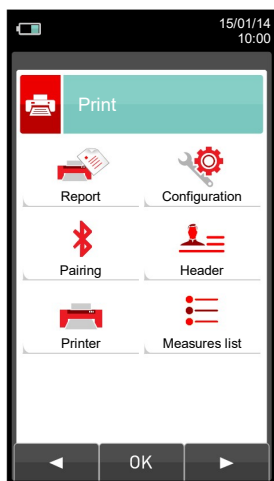

KEY	FUNCTION
	Activate the context keys shown on the display.
	Selects line; the selected line is displayed in red. In modification sets the value or the desired mode.
	Activates the context key located in the left side of the display.
	Returns to the previous screen. When in modify mode cancels the modification just made.

CONTEXT KEY	FUNCTION
	Selects the available parameters.
	Enters in the selected parameter setting.
	Selects the available parameters.
	Starts the search for Bluetooth devices.
	Quits and returns to the previous screen.
	Enters the modification mode for the selected parameter.
	Repeats the pairing procedure.
	Confirms the settings.
	Confirms the selected letter or digit.
	Cancels the letter or digit before the cursor.
	Cycles through uppercase, lowercase, symbols and special characters.

In the following pages the pairing procedure between the instrument and a Bluetooth printer is described.





1. Once the Bluetooth printer is configured, proceed as follows:

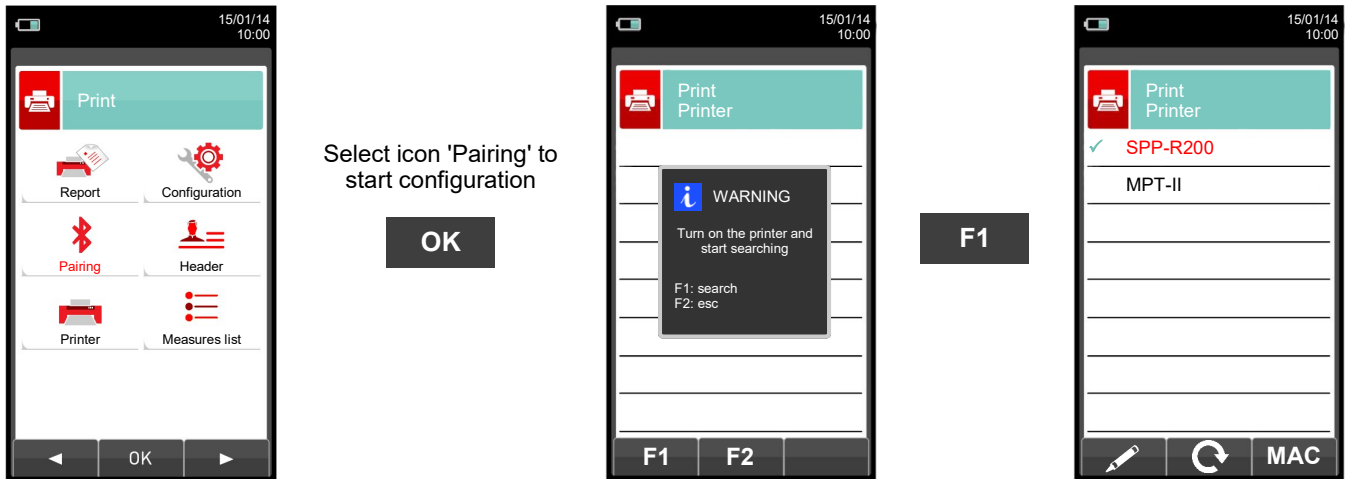

2. Select the line corresponding to the desired Bluetooth printer, then proceed as follows:

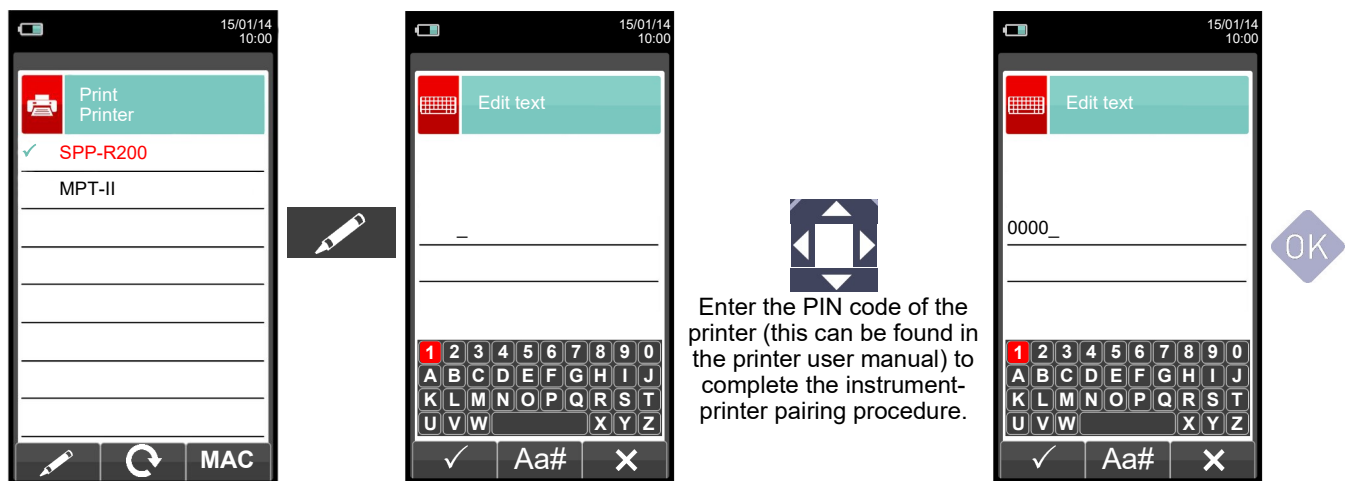

3. The instrument-printer pairing is completed. Press key 'ESC' to return to the previous screen.





12.6 Print→Header

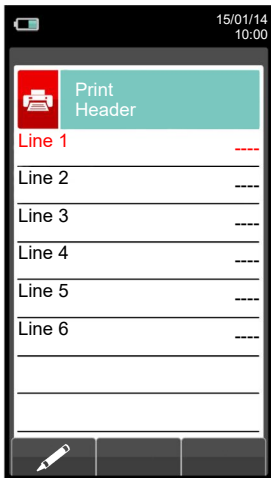

KEY	FUNCTION
	Activate the context keys shown on the display.
	In "edit text": It moves the cursor on the box corresponding to the letter or number required to form the desired word.
	In edit mode it moves the cursor through the available lines.
	In "edit text": it confirms the text input. In "Print header": It activates the context key displayed on the left.
	Returns to the previous screen. In "edit text" it goes back to the previous screen without saving the changes made.

CONTEXT KEY	FUNCTION
	Enters edit mode of the selected line: it is possible to enter the name of the operator (24 characters available).
	Confirms the selected letter or digit.
	Cancel the letter or digit before the cursor.
	Cycles through uppercase, lowercase, symbols and special characters.



Example:

1. Edit text

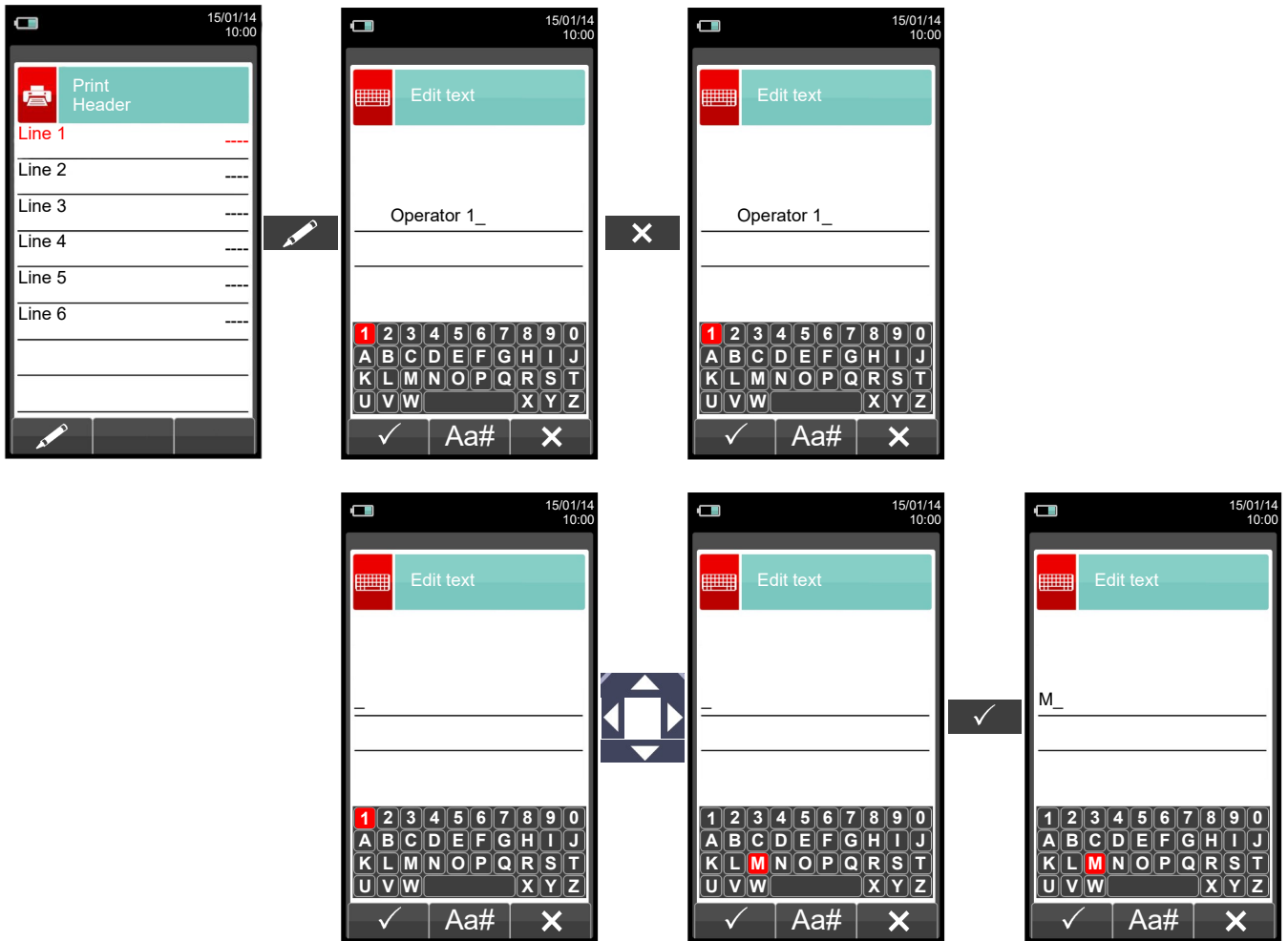

12.7 Print→Measures list

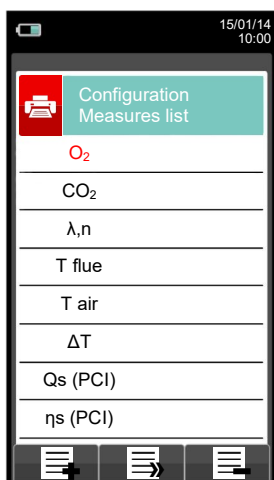

KEY	FUNCTION
	Activate the context keys shown on the display.
	Selects the available measurements from the suggested list. In edit mode, it scrolls through the measurements present.
	Confirms the modification.
	When pressed in modify mode cancels the selection made, otherwise returns to the previous screen.

CONTEXT KEY	FUNCTION
	Adds a measurement.
	Moves the position of a measurement.
	Deletes a measurement from the list.
	Scrolls through the available measurements.
	Confirms the change made.
	Scrolls through the available measurements.
	Cancels the change made.



Example:

1. Add a measurement to the list

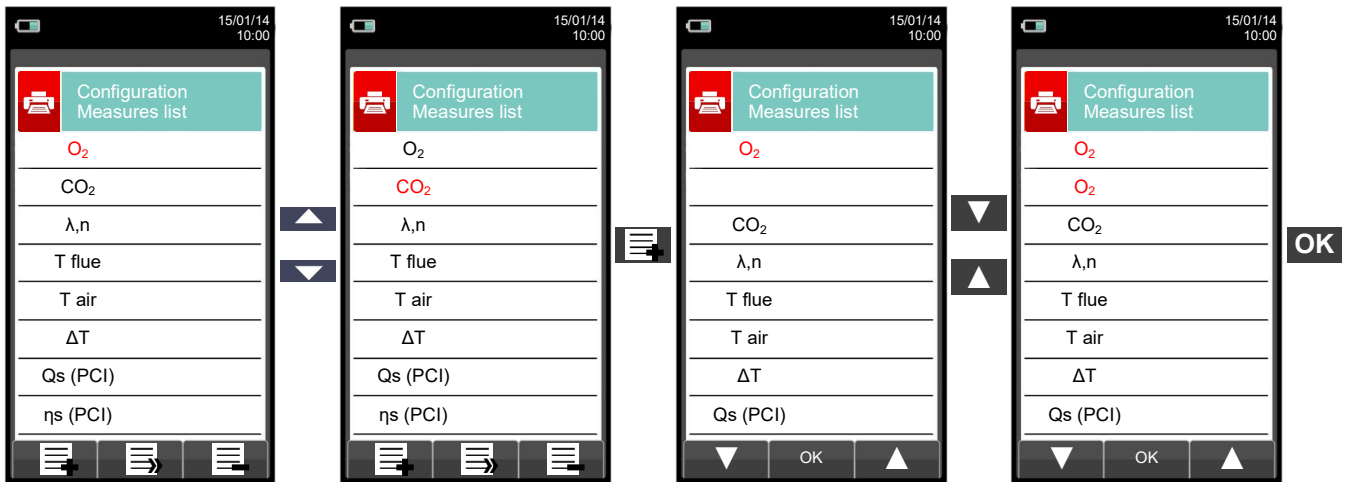

2. Move the position of a measurement

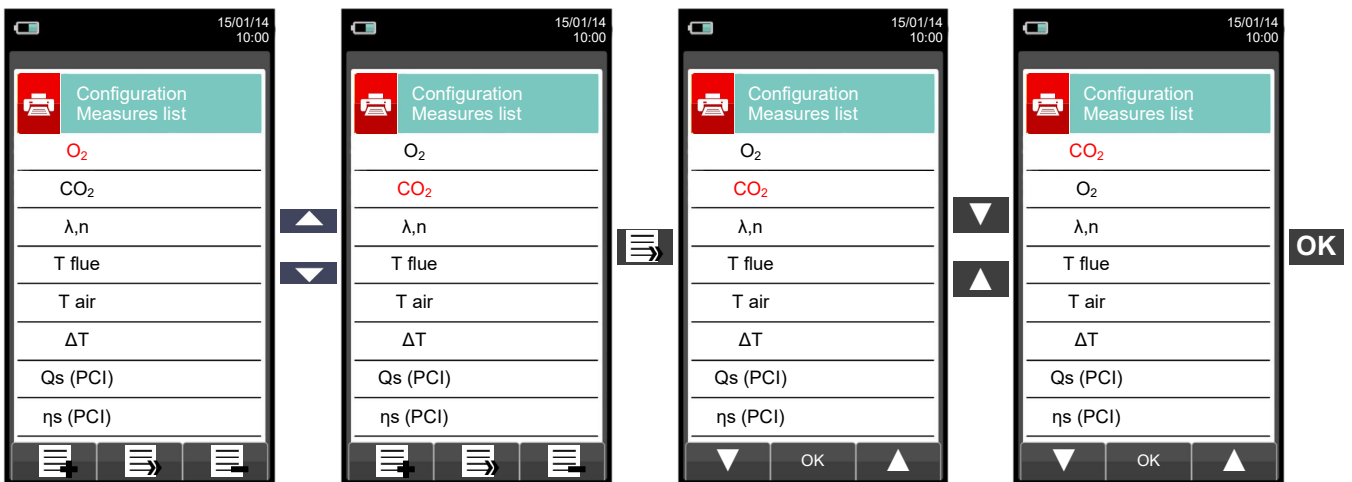

3. Deletes a measurement from the list

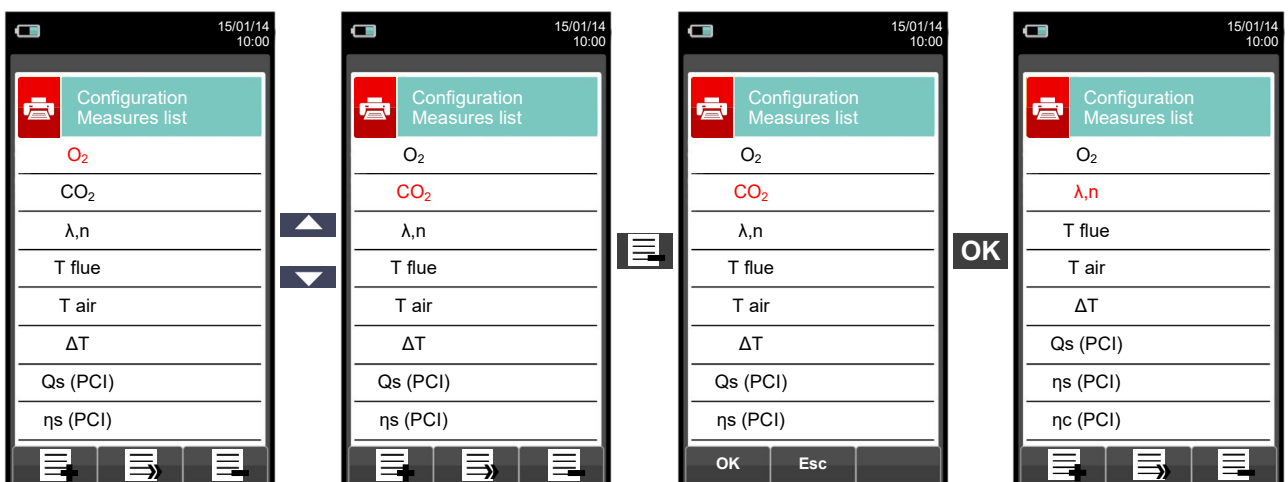

13.1 MEASUREMENTS

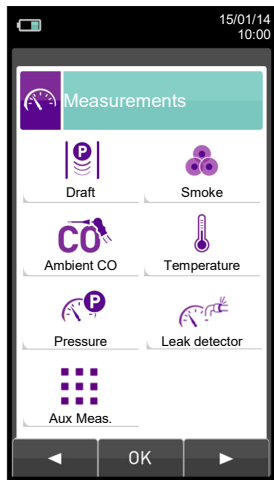



KEY	FUNCTION
	Activate the context keys shown on the display.
	Returns to the previous screen.

CONTEXT KEY	FUNCTION
	Selects the available parameters.
	Enters in the selected parameter setting.
	Selects the available parameters.

PARAMETER	DESCRIPTION
 Draft	<p>The DRAFT menu gives access to the stack draft measurement. Being a negative pressure draft must be measured using the negative pressure input P-. The correct values for a natural draft boiler are therefore positive by definition. Before performing the measurement the instrument allows the user to input the external air temperature as required by the standard. When making the measurement and the temperature has been inserted, the instrument provides a stack draft value related (P diff ref) to the external temperature of 68° F as requested by law. When the inserted external temperature is higher than 68° F the instrument reports a stack draft value reference equal to the measured draft. Afterwards the user can acquire the value displayed in order to add it to the running analysis measurements or, alternatively, print the relevant paper print-out through the 'PRINT' menu.</p> <p>NOTE: The measurement may not be accurate due to condensation inside the gas probe. Should you notice an inaccurate or unstable reading on the instrument, it is advisable to disconnect the gas probe from the instrument itself, and purge pipes by blowing with a compressor. In order to be sure there is no humidity, it is suggested to perform the measurement by means of the transparent rubber pipe supplied on issue.</p> <p>SEE SECTION 13.2.</p>
 Smoke	<p>It is possible to enter the data concerning one to three SMOKE measurements taken by means of an optional device (Smoke Pump Kit); see the relevant instructions.</p> <p>The method consists in taking a certain quantity of combustion gas from the middle of the flue behind the surfaces of the exchangers at the end of the boiler, and make it pass through a special filter paper. The smoke stain obtained is compared with the surfaces blackened in a different way according to a comparison scale; it is thus determined the "smoke number", which will be entered in the instrument by hand.</p> <p>These measurements can be either stored in memory together with the combustion analysis data or printed on a paper print-out.</p> <p>SEE SECTION 13.3.</p>
 Ambient CO	<p>This type of analysis lets the user measure the CO value present in the environment, with the scope of checking the personal safety conditions of a specific working environment. The instrument leaves our factory with the following pre-set threshold values:</p> <p>COmax: 35 ppm Recommended exposure limit (REL) stipulated by the National Institute for Occupational Safety and Health (NIOSH), equivalent to 40 mg/m³ and calculated as an 8-hour Time-Weighted Average (TWA).</p> <p> Make sure to perform the autozero in a clean environment (preferably outdoors), so that the ambient CO measurement is correct. It is advisable to turn on the instrument and wait for the autozero completion outside the area where the test is being performed.</p> <p>SEE SECTION 13.4.</p>







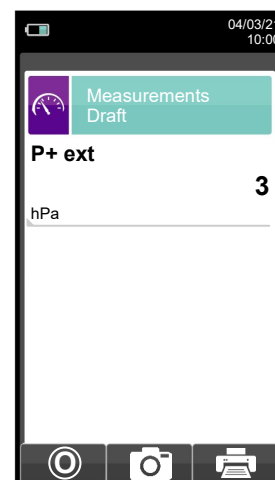

PARAMETER	DESCRIPTION
 Temperature	<p>With this menu it is possible to measure the temperature of the supply water, by means of an OPTIONAL thermocouple K-type contact probe to be connected to the input T1. Also, it is also possible to measure the temperature of the return water, by connecting an OPTIONAL thermocouple K-type contact probe to be connected to the input T1. With the function ΔT it is possible to obtain the relative temperature difference.</p> <p>SEE SECTION 13.5.</p>
 Pressure	<p>It is possible, through the use of the external flexible pipe made in RAUCLAIR (supplied), to measure a pressure value within the range stated in the technical features (connect the pipe to P+ input). During the pressure measurement the 'HOLD' function is made available, which allows to 'freeze' the value shown on the display, by pressing 'HOLD' key.</p> <p>SEE SECTION 13.6.</p>
 Aux meas.	<p>Through this menu the user can access additional measures.</p> <p>SEE SECTION 13.7.</p>



13.2 Measurements → Draft





To measure the draft proceed as follows:

- Connect the probe pressure input hose to the instrument **P+** input.
- Enter the external air temperature.
- Before starting the pressure zeroing sequence pay attention to remove the gas probe from the stack.

- Having carried out the pressure zeroing sequence, insert the probe in the stack and measure the draft.
- The draft values to be stored in the memory must be acquired before storing the analysis data.
- To attach the draft value to the readings of the current analysis, activate the "save" function '  '.
- To print the paper print-out with the value of the draft, activate the function '  '.
- It is possible to cancel an acquired draft from the memory; to overwrite a new one, activate the "save" function again '  '.
- After saving the draft measurement, to carry out the combustion analysis, press the key '  '.

KEY	FUNCTION
	Activate the context keys shown on the display.
	Sets the value of the external temperature.
	Returns to the previous screen.

CONTEXT KEY	FUNCTION
F1 F2 F3	The activation of one of these keys starts the Draft measurement.
	Carries out pressure zeroing.
	Saves, in the memory selected in the "Memory Select" menu, the value of the draft measured.
	Starts printing the paper print-out. SEE SECTION 12.



13.3 Measurements → Smoke



- Measure the smoke using the specific optional kit.
- Enter the values found.
- The values of the smoke that you want to save must be acquired before saving the analyses.
- To join the values of the smoke to the measurements of the current analysis use the ' ' function.
- To print the paper print-out with the measurement of the smoke, activate the ' ' function.
- It is possible to delete the values of the smoke acquired in the memory by overwriting them by activating the ' ' function again.
- After saving the smoke values, to carry out the combustion analysis, press the key ' '.

KEY	FUNCTION
	Activate the context keys shown on the display.
	Sets the "smoke number" found by the device when measuring the smoke.
	Returns to the previous screen.

CONTEXT KEY	FUNCTION
	Enters the modification mode for the selected parameter.
	Confirms the value entered.
	Saves, in the memory selected in the "Select Memory" menu, the values entered.
	Starts printing the paper print-out. SEE SECTION 12.

13.3.1 Measurements → AAPM02 – Manual Smoke Pump Kit

Field of application

The **smoke pump** determines the soot spot number in combustion.

Basic safety instructions

!!! Warning !!!

- Before using the smoke pump, warm it up to room temperature.
- After approx. 10 measurements, check the withdrawal probe up to the valve for soot deposit and, if present clean it. Apply the same to all the others pump parts; this operation should be done regularly (See chapter: "Maintenance of the pump").
- Occasionally test the smoke pump for leaks (see chapter: "Testing the pump for leaks"). It is recommended to keep the soot picture comparison scale always in its wrapper and thus clean.

!!! Read carefully !!!

- It is precondition that the smoke pump is exclusively used according to the intended use.
- Do not apply excessive force to the testing instrument. (It may break)

Test operation. Smoke Sampling.

Before taking the smoke sample, the burner should already be in operation for at least 5 minutes.

- A. Insert the filter paper in the opening on the pump head and clamp it with a clockwise rotation of the probe head.

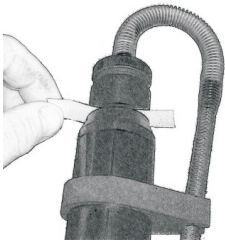

- B. Bring the probe tube through the measuring vent of the exhaust pipe in the middle of the flue-gas flow.

C. Perform 10 full suction strokes;

draw slowly and uniformly (suction stroke), shortly pause at the stop (pressure equalization), than move back fast. According to the prescription, $1.63 \pm 0.07 \text{ dm}^3$ exhaust gas are thereby drawn through the filter paper.

The operation time of the 10 strokes has to be 40-60 seconds.

- D. Release the probe head with a left-hand rotation and extract the filter paper stripe. A measuring spot with the corresponding coloring remains on the filter paper.
To define the exact soot number, you have to take at least 3 samples! The soot spot number is averaged out of them.

In case of a sluggish operation of the pump, lubricate the piston packing (see the chapter: "Lubrication of the soot pump")!

Test for oil derivate

- A. Test the measuring spot for oil-derivate. For that purpose, drop some acetone solvent next to the measuring spot. If there is no grey coloration, no oil is contained in the sample, which is correct.

Otherwise

If there is a grey coloration of the measuring spot: The exhaust gas contains oil! Inspect the oil burning installation!

- B. Hold the filter paper with the measuring spot behind the grey scales of the soot picture comparison scale until the spot appears fully in center and read off the soot spot number. The shade of grey looking more likely to the measuring spot density shows the soot spot number.

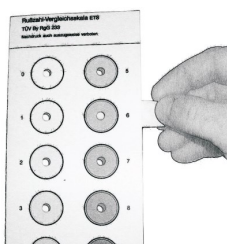

C. Now average over the soot spot numbers of all samples taken. This value, rounded up to the next whole number, is the value respectively the soot spot number of the installation.

Maintenance

Cleaning of the smoke pump.

Remove lightly adhering soot particles:

- For this purpose, make some firm pump strokes, the probe head slightly drawn and no filter paper inserted. Lightly adhering dirt will peel away also from the valve.

Disassembly of the smoke pump:

- Unscrew the cylinder cap with left-hand rotation.
- Carefully pull the piston out of the cylinder. Pay attention not to damage the piston packing on the thread inside of the cylinder!

When cleaning the piston package, do not take it off the piston rod!

- Unscrew the probe head with left-hand rotation.
- Screw off the valve using the supplied key through a left-hand rotation. Put the key securely into the keyhole.

To remove lubricant excesses, use only cleaning agents not affecting plastic material!

- Very dirty piston rods may be cleaned with fine-grained sandpaper.
- Clean the pump components with a cloth or a suitable brush.

Lubrication of the smoke pump

Before lubricating, the pump has to be cleaned (see chapter: "Cleaning of the smoke pump").

To lubricate the pump only use the provided lubricating oil!

Do not apply too much lubricant oil!

Do not use lubricants containing mineral oil!

- Drop some lubricant in the cylinder. Spread the lubricant oil on the piston packing and then put the piston back in.
- Move the piston in the cylinder until it runs smoothly.
- Mount the remaining components.

Testing the pump for leaks

- Turn the probe head under slight pressure to the valve support (clockwise rotation - clamping position)
- Hold the pump with handle towards the body so that the probe tube may be closed with the thumb (Of course you may also use other accessories for closing the probe tube).
- Pull the pump piston on the handle out for approx. 37,4 - 41 inches and let it loose. The handle should spring back in its initial position: in this case the pump is sealed.

or

- If the handle does not spring back in its initial position, the pump is leaked.





Possible causes:

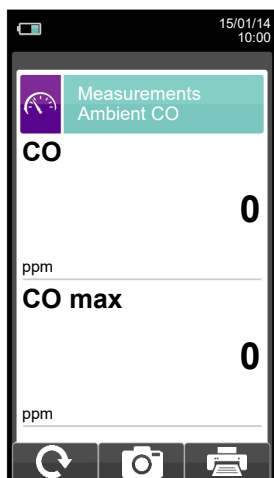

- rubber hose defect
- faulty valve or valve gasket
- crack in the piston packing



13.4 Measurements → Ambient CO



Make sure to perform the autozero in a clean environment (preferably outdoors), so that the ambient CO measurement is correct. It is advisable to turn on the instrument and wait for the autozero completion outside the area where the test is being performed.

- The values of the ambient CO that you want to save must be acquired before saving the analyses.
- To join the values of the ambient CO to the measurements of the current analysis use the '  ' function.
- To print the paper print-out with the measurement of the ambient CO, activate the '  ' function
- It is possible to delete a draft value acquired by the memory by overwriting it by activating the '  ' function again.
- After saving the draft values, to carry out the combustion analysis, press the key '  '.

KEY	FUNCTION
	Activate the context keys shown on the display.
	Returns to the previous screen.

CONTEXT KEY	FUNCTION
	Updates the measurement.
	Saves, in the memory selected in the "Select Memory" menu, the data acquired.
	Starts printing the paper print-out. SEE SECTION 12.



13.5 Measurements → Temperature

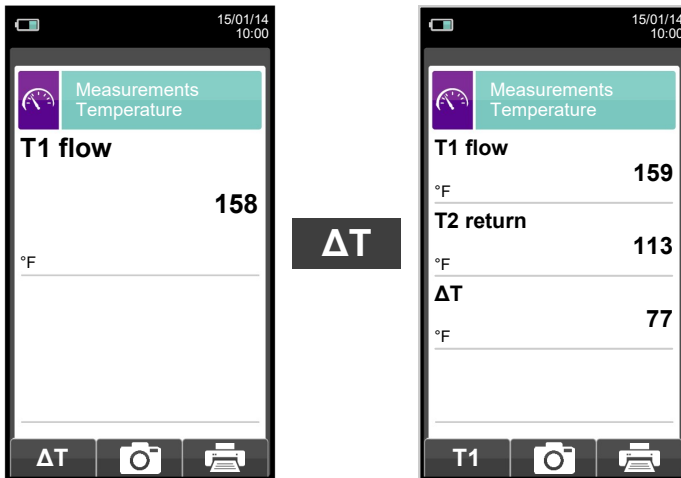

KEY	FUNCTION
	Activate the context keys shown on the display.
	Returns to the previous screen.

CONTEXT KEY	FUNCTION
	Accesses the acquisition of the temperature difference between the supply water (measured by the probe connected to the connector T1 of the device) and the return water (measured by the probe connected to the connector T2 of the device).
	Goes back to the visualisation of the supply water temperature.
	Saves, in the memory selected in the "Select Memory" menu, the data acquired.
	Starts printing the paper print-out. SEE SECTION 12.



13.6 Measurements → Pressure



← Measurement of the differential pressure by means of the internal pressure sensor.

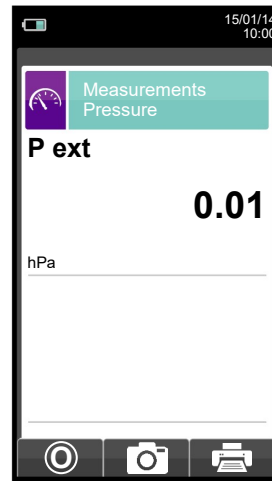

← Measurement of the pressure by means of an external draft gauge.

KEY	FUNCTION
	Activate the context keys shown on the display.
	Returns to the previous screen.

CONTEXT KEY	FUNCTION
	Performs pressure zeroing.
	Saves, in the memory selected in the "Select Memory" menu, the data acquired.
	Starts printing the paper print-out. SEE SECTION 12.

13.7 Measurements → AUX measurements

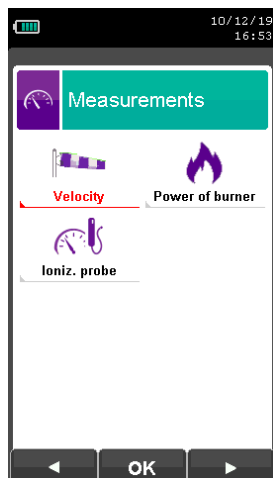

KEY	FUNCTION
	Activate the context keys shown on the display.
	Returns to the previous screen.

CONTEXT KEY	FUNCTION
	Selects the available parameters.
	Enters in the selected parameter setting.
	Selects the available parameters.

PARAMETER	DESCRIPTION
 Velocity	When a Pitot tube and a Tc-K thermocouple are connected, the instrument is capable to measure at the same time both temperature and velocity of a gas (air/flue gas). SEE SECTION 13.8.
 Power of burner	Thermal power of the burner The measurement of the thermal power at the burner can be performed in different ways, depending on the type of fuel selected. Boilers using gaseous fuels FLOW: if the system is equipped with a volumetric flow meter just enter the value of the fuel volume flow (m ³ / h). COUNTER: this mode can be used if the system is equipped with a volumetric flow meter. The volume flow is calculated by reading on the counter, while the generator is in steady operation, the volume of gas flown in a time interval of at least 120 s. MANUAL: if the procedure was provided by the manufacturer and appropriate instructions have been specified on the user manual, the operator can find out the thermal power of the burner and enter it manually. In the absence of counter or any other system for measuring the flow, the nominal thermal power of the boiler stated by the manufacturer is to be assumed as the proper value. Boilers using liquid fuels FLOW: the value of the mass flow rate (kg / h) of the fuel must be entered. MANUAL: if the procedure was provided by the manufacturer and appropriate instructions have been specified on the user manual, the operator can find out the thermal power of the burner and enter it manually. In the absence of counter or any other system for measuring the flow, the nominal thermal power of the boiler stated by the manufacturer is to be assumed as the proper value. SEE SECTION 13.9.
 Ioniz. probe	You can measure the ionization current of a boiler and test its value based on the technical features of the boiler by connecting the ionization probe (optional) to the serial port (See section 8.5 and/or section 8.5.9). SEE SECTION 13.10.



13.8 Measurements → Velocity

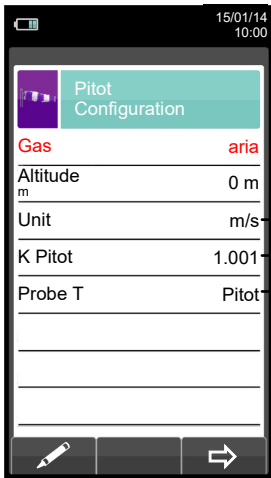

- ➔ Measurement: air or flue gas.
- ➔ Altitude above sea level.
- ➔ Measurement unit selectable across m/s, km/h, fpm, mph.
- ➔ Insert the K-factor of the Pitot tube stated by the tube manufacturer.
- ➔ Temperature acquisition mode:
Pitot (with Tc-K thermocouple) or Flue gas probe (or external Tc-K thermocouple).

KEY	FUNCTION
	Activate the context keys shown on the display.
	Selects line; the selected line is displayed in red. In edit mode, it sets the desired value.
	Activates the context key located in the left side of the display.
	Returns to the previous screen. When in modify mode cancels the modification just made.

CONTEXT KEY	FUNCTION
	Enters the modification mode for the selected parameter.
	Confirms the value entered.
	Go to next step.
	Make the zero for the measurement.
	Saves, in the memory selected in the "Select Memory" menu, the data acquired.
	Starts printing the paper print-out. SEE SECTION 12.



13.8.1 How to connect the Pitot tube to the instrument

- Connect the Pitot tube (accessory) to inputs P+ and P- (which are normally used for the differential pressure measurement)
- Connect the Tc-K thermocouple cable from the flue gas probe to connector T1 of the instrument.

WARNING: when a Pitot tube integrated to a Tc-K thermocouple is used, remember to connect the thermocouple connector to T1 input at instrument side. In this case the flue gas probe must not be connected.

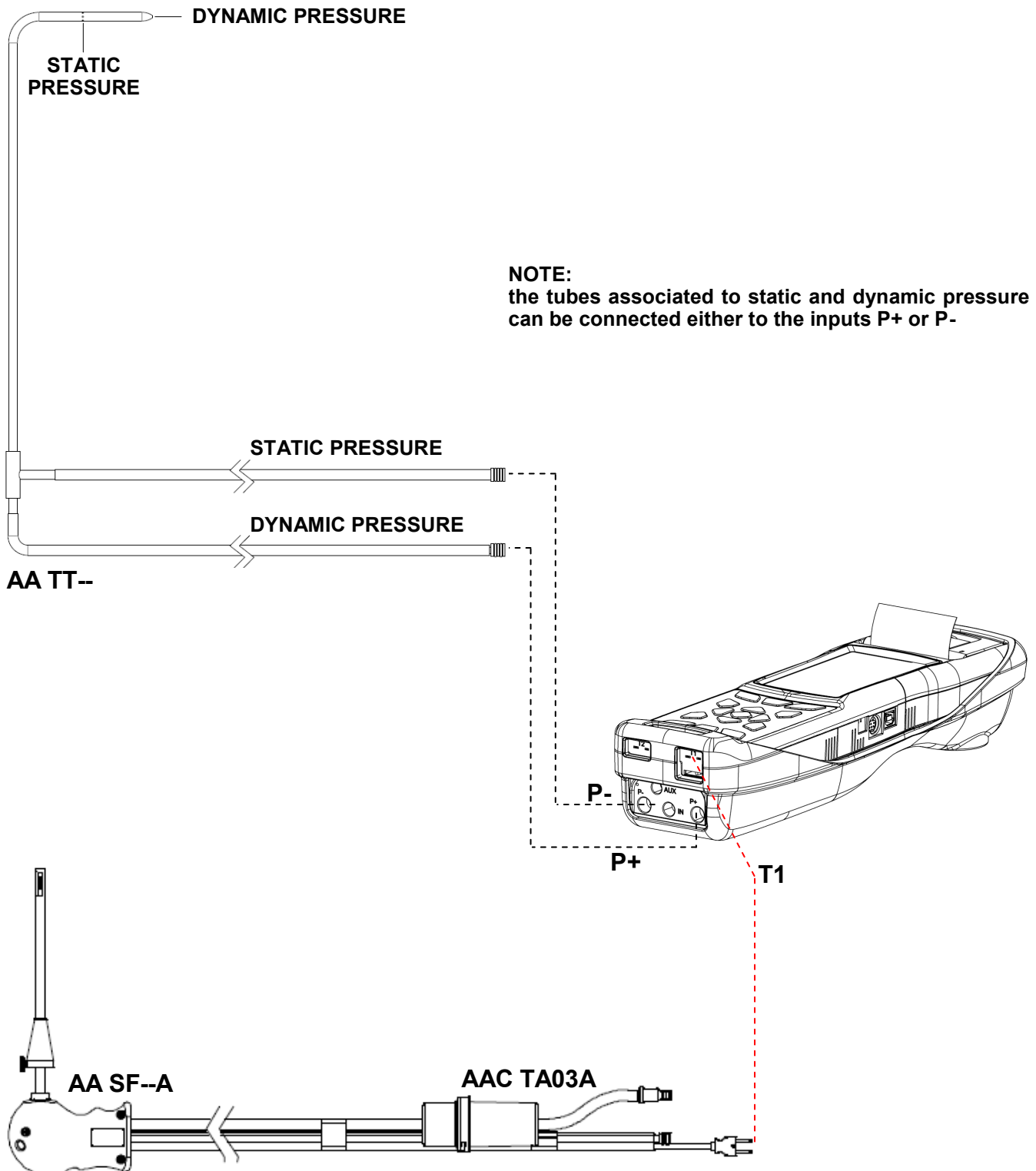

13.8.2 TEST EXECUTION

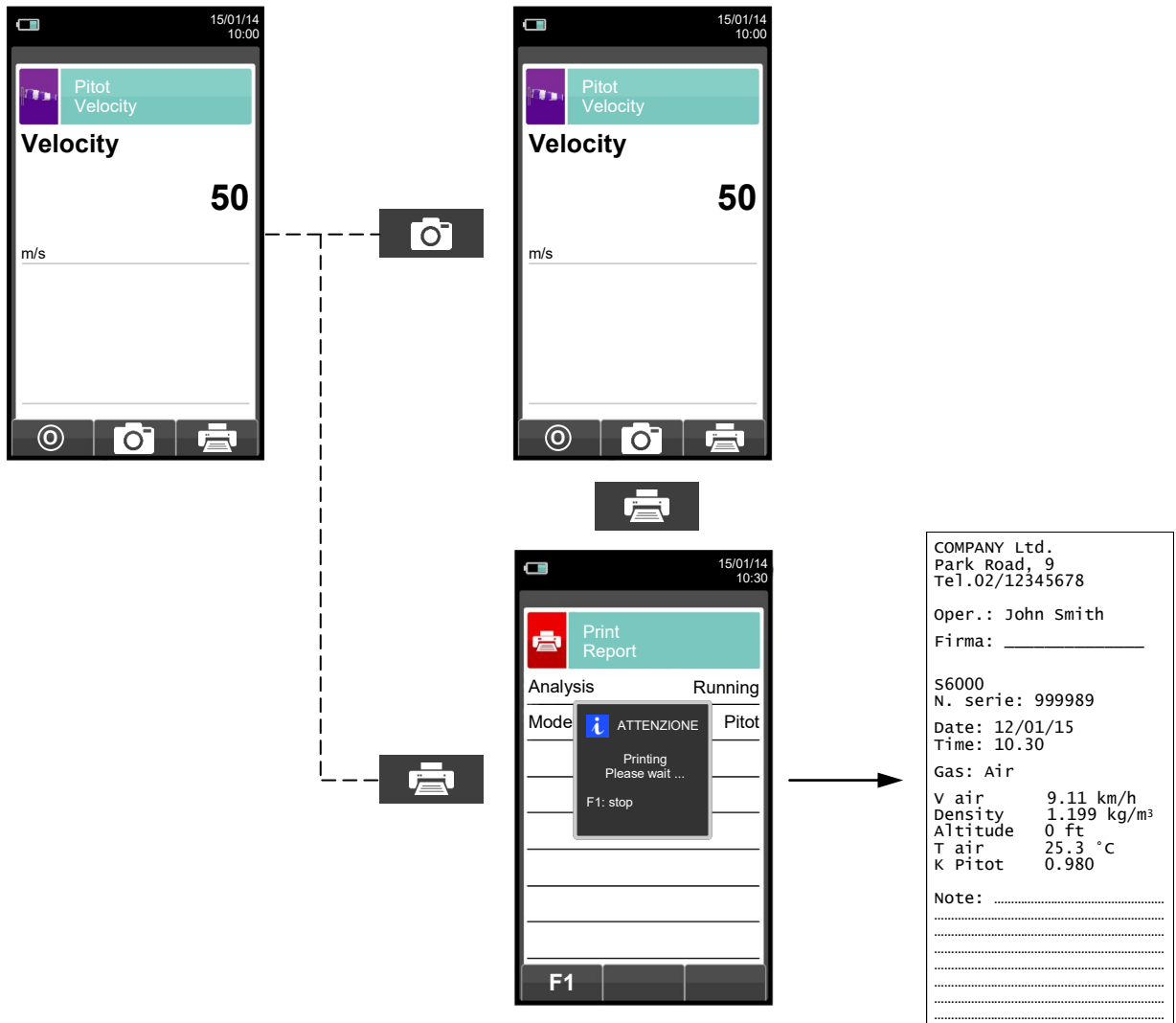

13.9 Measurements → Power of burner

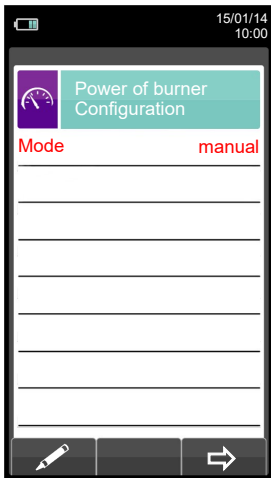

Enter the thermal power value calculated manually by the operator.

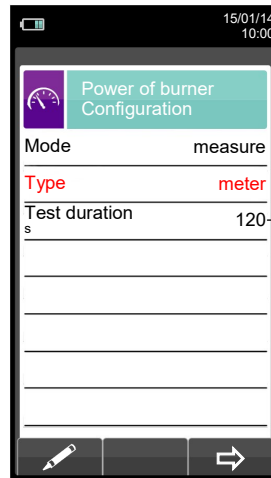

Test mode: you can choose to calculate the thermal power by entering a flow value, or by reading the volumetric counter (gaseous fuels only).

Duration of test: the option is displayed only for the test mode 'COUNTER', available for gaseous fuels. It is possible to enter the number of seconds between the reading of the initial and final gas volume. The minimum time required by law is 120 s.

KEY	FUNCTION
	Activate the context keys shown on the display.
	Selects line; the selected line is displayed in red. When in modify mode, sets the desired value.
	In change moves the cursor to the box corresponding to the desired number to set the desired value.
	Activates the context key located in the left side of the display.
	Returns to the previous screen. When in modify mode cancels the modification just made.

CONTEXT KEY	FUNCTION
	Enters the modification mode for the selected parameter.
	Confirms the settings.
	Go to next step.
	Saves, in the memory selected in the "Memory Select" menu, the value of the draft measured.
	Stops the test.

13.9.1 TESTING IN 'MANUAL' MODE

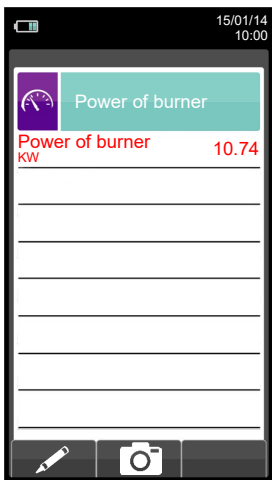
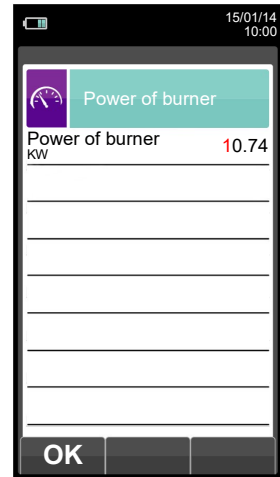
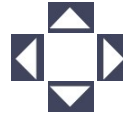
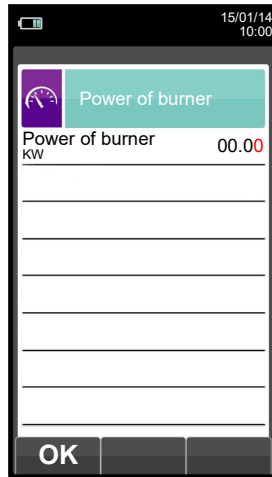
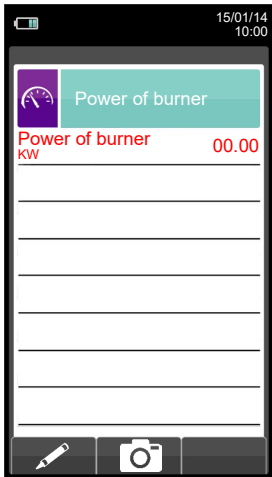

13.9.2 TESTING IN 'MEASURE' MODE (based on Flow rate)

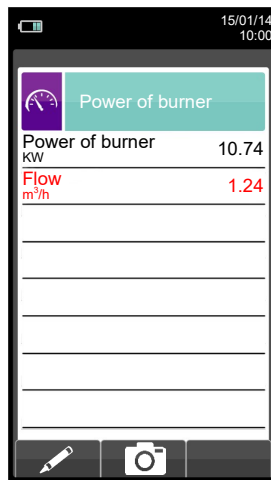
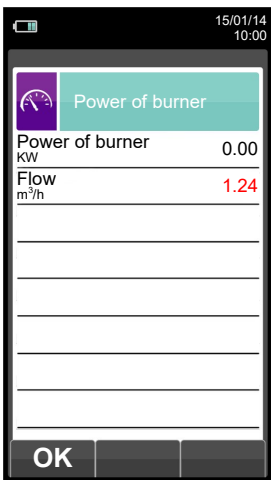
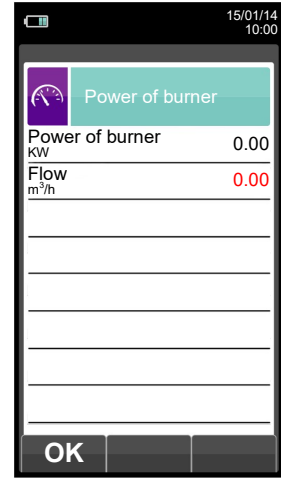
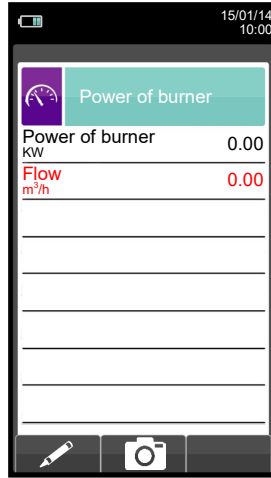
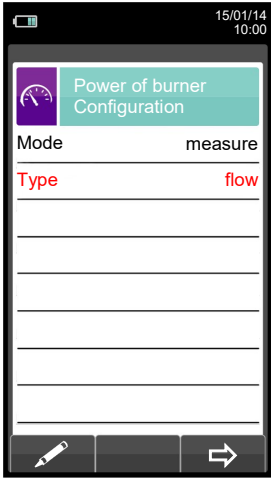

13.9.3 TESTING IN 'MEASURE' MODE (based on meter)

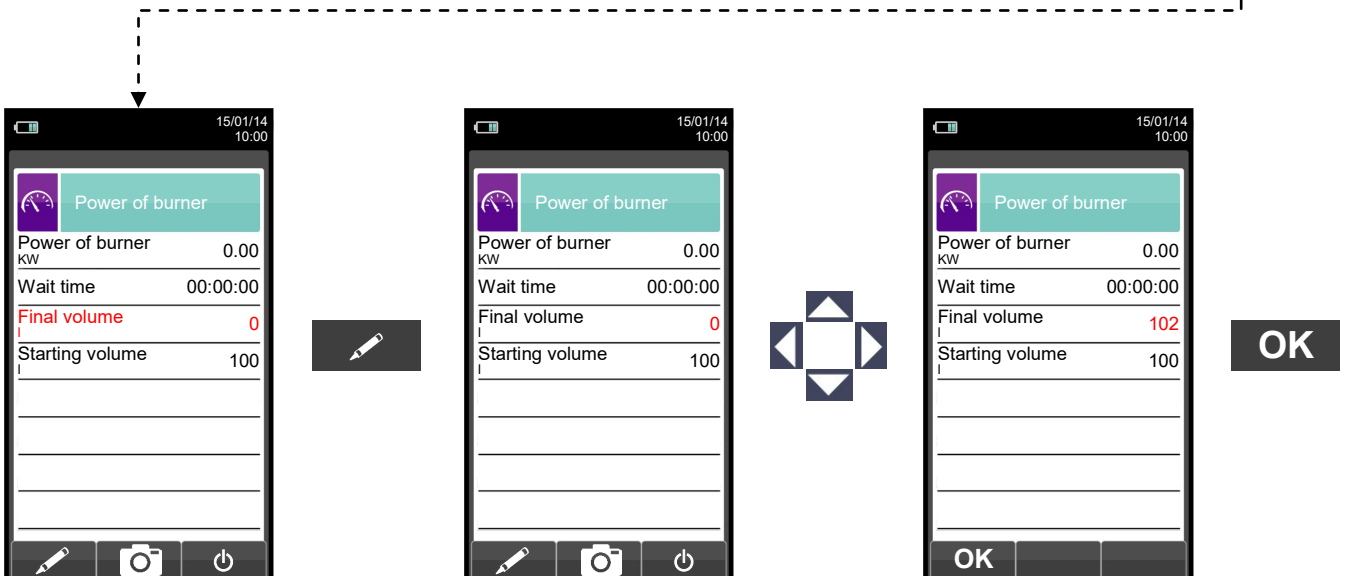
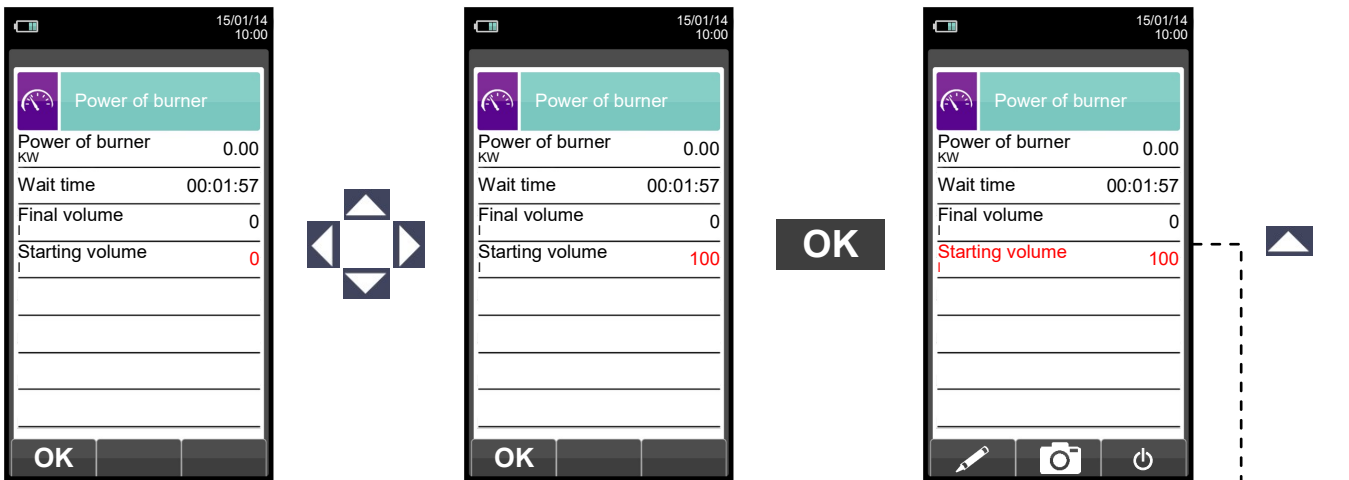
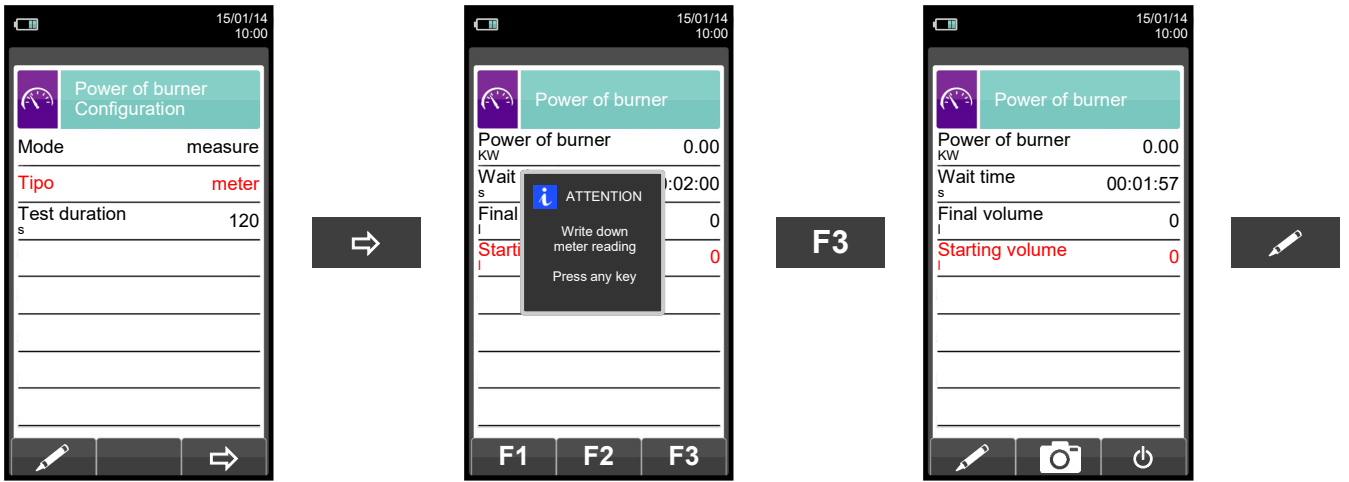



15/01/14
10:00

Power of burner	
Power of burner KW	0.56
Wait time	00:00:00
Final volume	102
Starting volume	100



✎ 📷 🔌



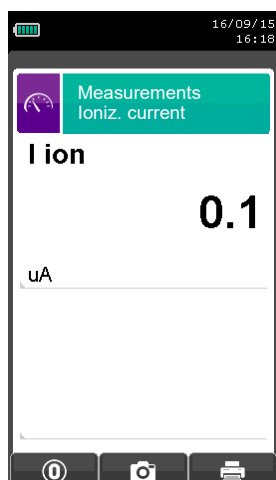

13.10 Measurements → Ionization current

Optional Ionization Probe Part # AACSO01 needed for this measurement



KEY	FUNCTION
	Activate the context keys shown on the display.
	Sets the value of the external temperature.
	Returns to the previous screen.

CONTEXT KEY	FUNCTION
	Performs current zeroing.
	Saves the acquired current value in the memory selected in the "Select Memory" menu.
	Starts printing the paper print-out. SEE SECTION 12.

14.1 FLUE GAS ANALYSIS



To perform complete flue gas analysis, follow the instructions below.



SOME IMPORTANT WARNINGS TO CONSIDER DURING THE COMBUSTION ANALYSIS ARE LISTED BELOW:

FOR A CORRECT ANALYSIS NO AIR MUST FLOW INTO THE PIPE FROM OUTSIDE DUE TO A BAD TIGHTENING OF THE CONE OR A LEAK IN THE PIPELINE.

THE GAS PIPE MUST BE CHECKED IN ORDER TO AVOID ANY LEAKAGES OR OBSTRUCTIONS ALONG THE PATH.

THE CONNECTORS OF THE GAS SAMPLING PROBE AND OF THE CONDENSATE FILTER MUST BE WELL CONNECTED TO THE INSTRUMENT.

KEEP THE CONDENSATE TRAP IN THE VERTICAL POSITION DURING THE ANALYSIS; A WRONG POSITIONING MAY CAUSE CONDENSATE INFILTRATIONS IN THE INSTRUMENT AND THUS DAMAGE THE SENSORS.

DO NOT PERFORM ANY MEASUREMENT WHEN THE FILTER IS REMOVED OR DIRTY IN ORDER TO AVOID ANY RISK OF IRREVERSIBLE DAMAGES ON SENSORS.

14.1.1 Switching on the instrument and auto-calibration

Press the On/Off key to switch on the instrument - an introductory screen will appear. After a couple of moments the instrument will zero itself.



DURING INSTRUMENT AUTOZERO, THE SAMPLING PROBE MUST NOT BE INSERTED IN THE STACK.

IT IS IMPORTANT THAT THE SAMPLE PROBE IS NOT INSIDE THE STACK SINCE DURING AUTOZERO PROCESS THE INSTRUMENT DRAWS FRESH AIR FROM THE ENVIRONMENT AND DETECTS THE ZERO VALUE OF SENSORS (O₂, CO, NO, ..) THE DETAILS OF WHICH ARE THEN SAVED AND USED FOR REFERENCE DURING THE ANALYSIS. IT IS EQUALLY IMPORTANT THAT THIS PHASE IS PERFORMED IN A FRESH-AIR ENVIRONMENT.

14.1.2 Inserting the probe inside the stack

When auto-calibration is complete the instrument will instruct the user to insert in the stack the sample probe that has been previously connected to the relative input on the instrument, and the analysis screen will appear automatically.

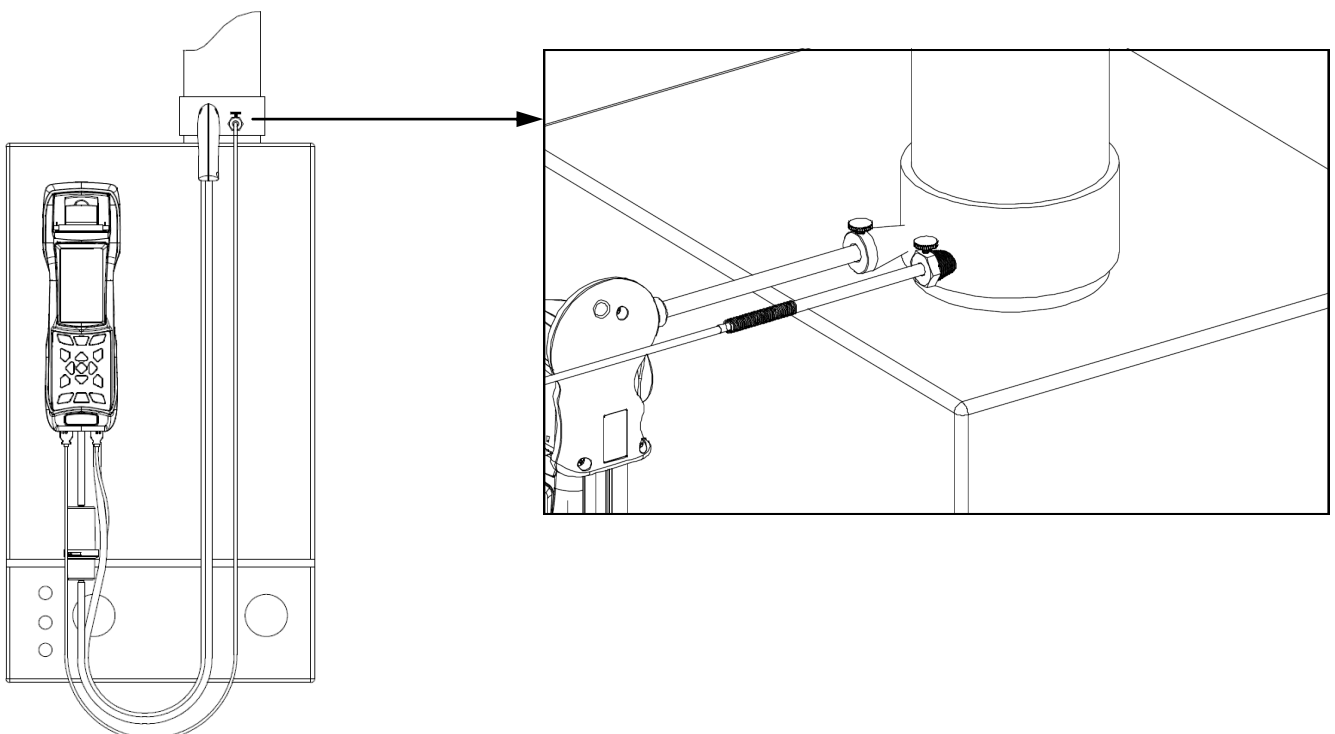



In order for the probe to be inserted at the right point within the stack, its distance from the boiler has to be twice the diameter of the stack pipe itself or, if this is not possible, must comply with the boiler manufacturer's instructions.

In order to position the probe correctly, a reliable support must be provided by drilling a 0.5"/0.6" hole in the manifold (unless already present) and screwing in the positioning cone provided with the probe - in this way no air is drawn from the outside during sampling.

The screw on the cone allows the probe to be stopped at the right measuring depth - this usually corresponds to the centre of the exhaust pipe.

For greater positioning accuracy, the user may insert the probe gradually into the pipe until the highest temperature is read. The exhaust pipe must be inspected before carrying out the test, so as to ensure that no constrictions or losses are present in the piping or stack.

14.1.3 Simultaneous measurement of pressure, O₂, pollutants

In order to measure simultaneously pressure, O₂ and pollutants levels as well as all the others calculated parameters necessary to obtain the correct performance value, connect the instrument as follows:

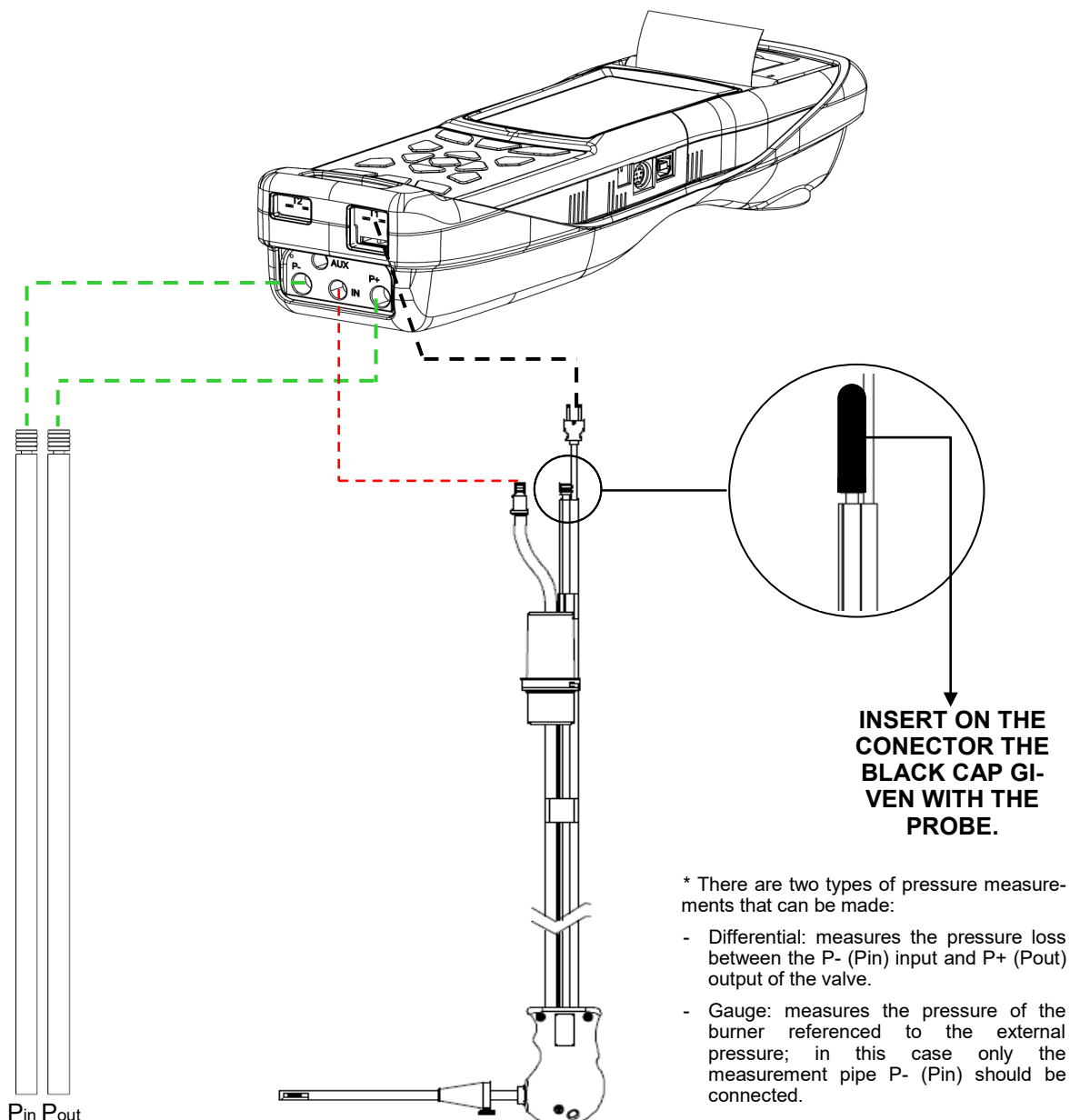



14.1.4 Flue Gas Analysis

After the sample probe has been inserted in the stack and the combustion air temperature probe (if used) has been inserted in the relative sample manifold, if the instrument has not been configured during auto-calibration, the following data must be configured:

Memory: use this submenu to define the memory in which the test data and client details are to be stored.

Fuel: select the type of fuel burned in the combustion equipment producing the flue/exhaust gas being measured.

Operator: this is where the name of the test operator can be entered.

Mode: by entering this submenu, the user can determine the analysis mode - manual or automatic.

If automatic mode is chosen, the reading duration of each and every test must be set, besides the printing mode - manual or automatic. When flue gas analysis begins, the instrument will perform and memorize the three tests automatically, at the respective intervals set.

At the end of each test the instrument will emit an audible alarm (one "beep" after the first test, two "beeps" after the second test and three "beeps" after the third test).

At this point, when all three tests are over, if "Manual Printing" has been chosen the instrument will display the average of the three tests with the possibility of recalling the individual values.

If desired, the user can then print the relative data (total, complete, etc....). On the contrary, if "Automatic Printing" was selected, the instrument will print the test data automatically, based on the current print settings, without displaying the average test values.

Caution: when in automatic mode Draft, Smoke and ambient CO (NO) measurements must be taken before initiating the flue gas analysis.



If, on the other hand, manual analysis mode is chosen, flue gas analysis will proceed manually (please see relative Flow Chart). In this case the print settings and automatic test duration will not be considered.

At this point manual analysis may commence, first waiting at least two minutes until the displayed values stabilize: The user can then proceed with data storage, if required, or print the analysis report directly.

The latter will be printed in the format set beforehand.

When all three tests are over, the user can recall the average analysis screen containing all the data necessary for compiling the maintenance log of the boiler or plant.

While in manual analysis, holding pressed both keys  and  makes the instrument switch off the gas sampling pump and blocks the refresh of any current measure.

To switch on the gas sampling pump again and reactivate the refresh of the current measure, press again the keys  and .

In both modes, automatic and manual, the displayed data of the pollutants CO / NO / NO_x can be translated into normalized values (with reference to the concentration of O₂ previously set).

14.1.5 End of Analysis

At the end of the combustion analysis, carefully remove the sample probe and remote air temperature probe, if used, from their relative stacks, taking care not to get burnt. It is recommended to purge the analyzer with clean fresh air for at least 5 to 10 minutes before turning off the instrument by pressing the On/Off key.

At this point, if the instrument has detected a high concentration of CO and/or NO, a self-cleaning cycle will be initiated during which the pump will draw fresh outside air until the gas levels drop below acceptable values.

At the end of the cycle (lasting no longer than 3 min.) the instrument will switch itself off automatically.

14.2 FLUE GAS ANALYSIS - PRELIMINARY OPERATIONS

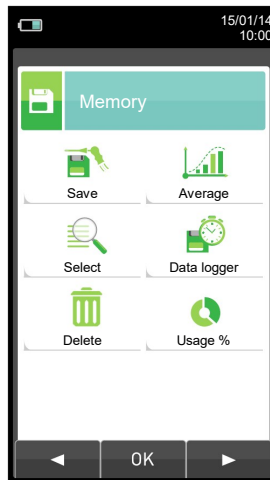
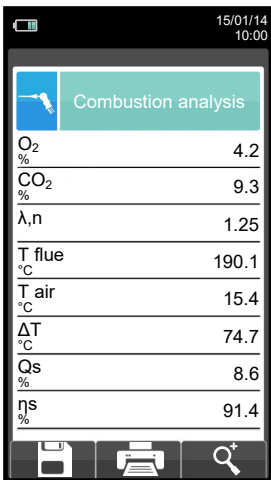
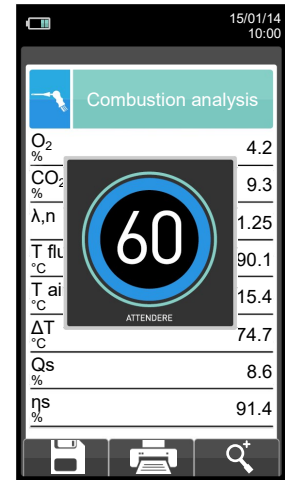
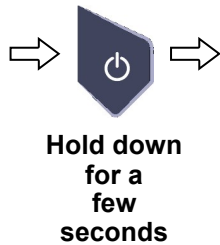
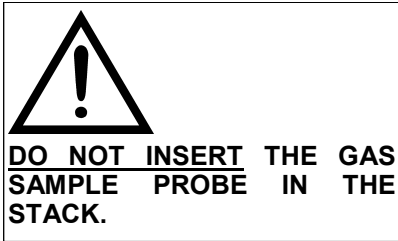

PARAMETERS TO SET BEFORE PROCEEDING (SEE SECTION 11.0):

Select Data logger

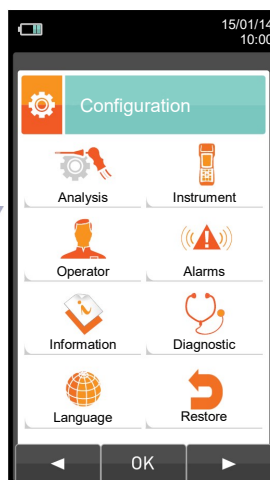
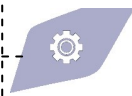

PARAMETERS TO SET BEFORE PROCEEDING (SEE SECTION 10.0):

Analysis Operator

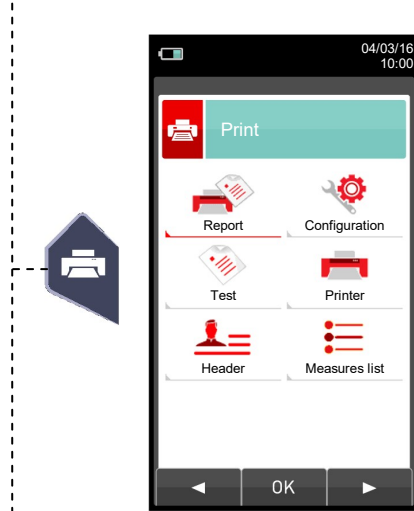

PARAMETERS TO SET BEFORE PROCEEDING (SEE SECTION 12.0):
Configuration
Header
Measures list

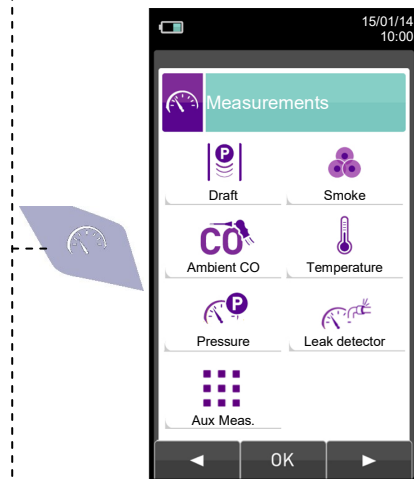



ACQUIRE THE FOLLOWING MEASUREMENTS BEFORE PROCEEDING WITH THE COMBUSTION ANALYSIS (SEE SECTION 13.0):

 **In you don't, the measurements will not be printed with the combustion analysis.**

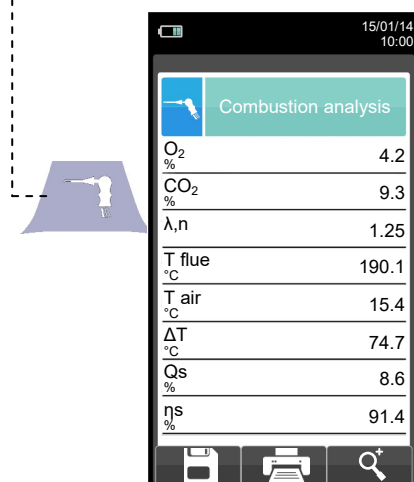
Draft
Smoke
Ambient CO
Temperature
Pressure



PRESS THE KEY '  ':
It starts saving the current analysis according to the set mode.
 - Manual [See section 14.3](#)
 - Data logger [See section 14.4](#)

PRESS THE KEY '  ':
It starts the printing on paper print-out of the current analysis; additional measurements are also printed, if they are present in the memory.



14.3 PERFORMING COMBUSTION ANALYSIS - MANUAL MODE



Combustion analysis	
O ₂ %	4.2
CO ₂ %	9.3
λ,n	1.25
T flue °C	190.1
T air °C	15.4
ΔT °C	74.7
Qs %	8.6
ηs %	91.4



Memory Save	
Mode	manual
Memory	12
Analysis	1

OK
Saves analysis number 1

Combustion analysis	
O ₂ %	4.2
CO ₂ %	9.3
λ,n	1.25
T flue °C	190.1
T air °C	15.4
ΔT °C	74.7
Qs %	8.6
ηs %	91.4



Memory Save	
Mode	manual
Memory	12
Analysis	2

OK
Saves analysis number 2

Combustion analysis	
O ₂ %	4.2
CO ₂ %	9.3
λ,n	1.25
T flue °C	190.1
T air °C	15.4
ΔT °C	74.7
Qs %	8.6
ηs %	91.4



Memory Save	
Mode	manual
Memory	12
Analysis	3

OK
Saves analysis number 3

Combustion analysis	
O ₂ %	4.2
CO ₂ %	9.3
λ,n	1.25
T flue °C	190.1
T air °C	15.4
ΔT °C	74.7
Qs %	8.6
ηs %	91.4



Memory	
Save	Average
Select	Data logger
Delete	Usage %

Recalls the average analysis.



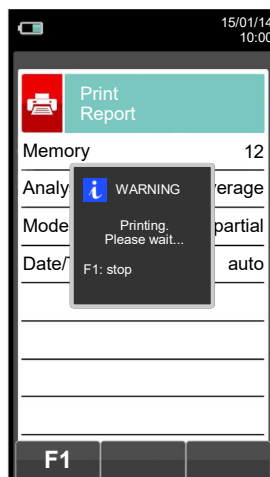
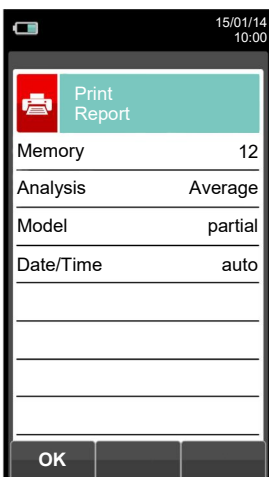
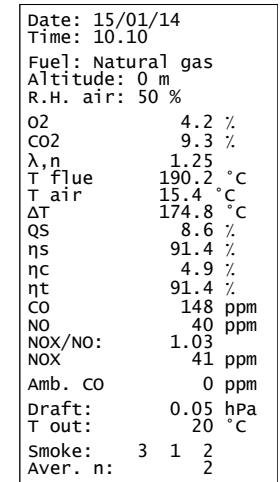
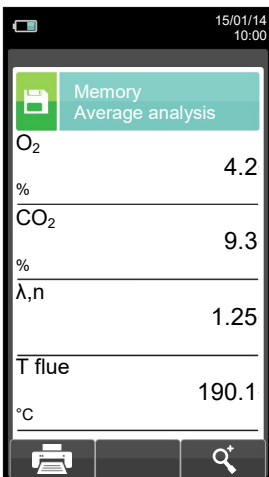
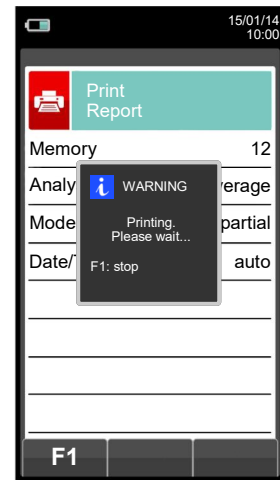
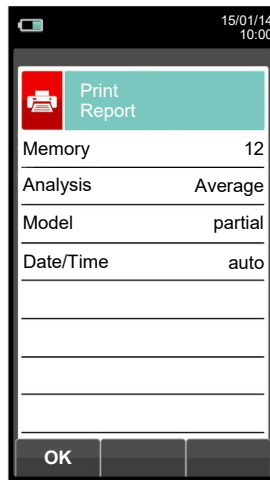
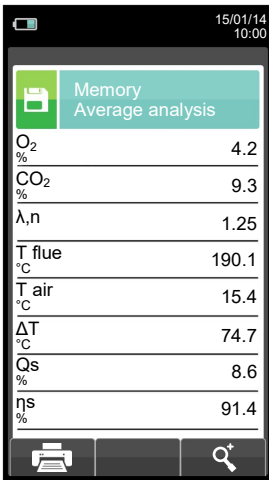

14.6 PERFORMING THE COMBUSTION ANALYSIS - Data logger MODE



15/01/14
10:00

Combustion analysis

O ₂ %	4.2
CO ₂ %	9.3
λ,n	1.25
T flue °C	190.1
T air °C	15.4
ΔT °C	74.7
Qs %	8.6
ηs %	91.4

Save Print Search



15/01/14
10:00

Memory Save

Mode	data logger
Memory	1
Samples	10
Interval s	60

OK



15/01/14
10:00

Combustion analysis data logger

O ₂ %	4.2
CO ₂ %	9.3
λ,n	1.25
T flue °C	190.1
T air °C	15.4
ΔT °C	74.7
Qs %	8.6
ηs %	91.4

Power 1 60 Search



15/01/14
10:02

Combustion analysis data logger

O ₂ %	4.2
CO ₂ %	9.3
λ,n	1.25
T flue °C	190.1
T air °C	15.4
ΔT °C	74.7
Qs %	8.6
ηs %	91.4

WARNING
Data logger active.
Interrupt?
F1: Interrupt
F2: continue
F3: pause

F1 F2 F3



Automatically saves the first sample when the set time is over.

15/01/14
10:02

Combustion analysis data logger

O ₂ %	4.2
CO ₂ %	9.3
λ,n	1.25
T flue °C	190.1
T air °C	15.4
ΔT °C	74.7
Qs %	8.6
ηs %	91.4

Power 2 60 Search

Automatically saves the second sample when the set time is over and so on until the last sample.





NOTE: If, while configuring the tightness test the automatic printing mode has been selected, the tightness test is printed automatically.

Instead, if the manual printing mode has been selected (exemplified case), at the end of the tightness test the results are displayed and they can be saved and/or printed. In this case proceed as follows:

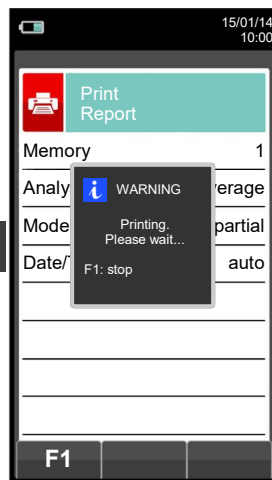
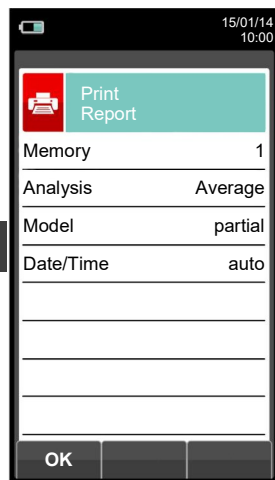
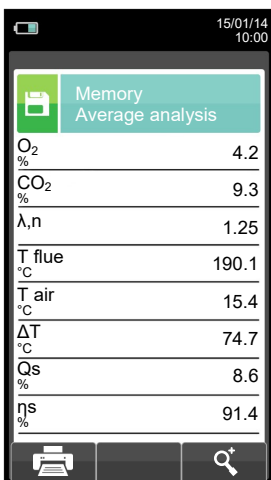

Date:	15/01/14
Time:	10.10
Fuel:	Natural gas
Altitude:	0 m
R.H. air:	50 %
O2	4.2 %
CO2	9.3 %
λ,n	1.25
T flue	190.2 °C
T air	15.4 °C
ΔT	174.8 °C
Qs	8.6 %
ηs	91.4 %
ηc	4.9 %
ηt	91.4 %
CO	148 ppm
NO	40 ppm
NOX/NO:	1.03
NOX	41 ppm
Amb. CO	0 ppm
Draft:	0.05 hPa
T out:	20 °C
Smoke:	3 1 2
Aver. n:	2

15.0 SENSORS

15.1 Sensors arrangement

SENSORS ARRANGEMENT INSIDE THE SENSORS COMPARTMENT

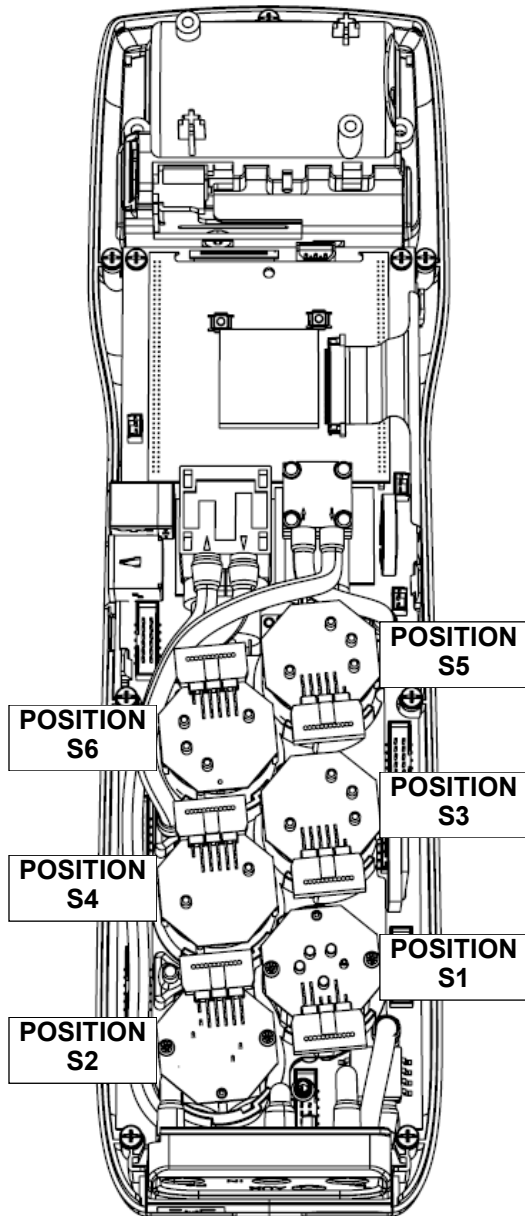

GRAPHICAL DISPLAY OF ARRANGEMENT

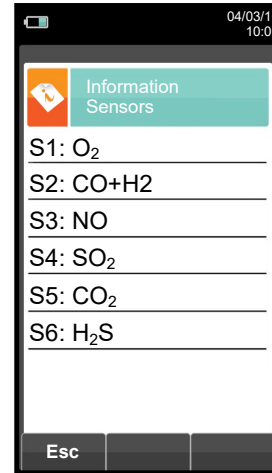

15.2 Sensor types and relevant positioning

CODE	POSITION	S1	S2	S3	S4	S5	S6
	Flex-Sensor O₂ LL Cod. AACSE44		✓	✓	✓		
Flex-Sensor O₂ Cod. AACSE15R		✓	✓	✓	✓	✓	✓
Flex-Sensor CO+H₂ Cod. AACSE12			✓				
Flex-Sensor CO+H₂ low range Cod. AACSE24			✓				
Flex-Sensor CO 100.000 ppm Cod. AACSE17		✓	✓	✓	✓	✓	✓
Flex-Sensor CO 20.000 ppm Cod. AACSE18		✓	✓	✓	✓	✓	✓
Flex-Sensor NO Cod. AACSE10		✓	✓	✓			
Flex-Sensor NO low range Cod. AACSE25		✓	✓	✓			
Flex-Sensor NO₂ Cod. AACSE14		✓	✓	✓	✓	✓	✓
Flex-Sensor NO₂ low range Cod. AACSE26		✓	✓	✓	✓	✓	✓
Flex-Sensor SO₂ Cod. AACSE13		✓	✓	✓	✓	✓	✓
Flex-Sensor SO₂ 1.000 ppm Cod. AACSE77		✓	✓	✓	✓	✓	✓
Flex-Sensor SO₂ low range Cod. AACSE28		✓	✓	✓	✓	✓	✓
Flex-Sensor CxHy 0-5.00% vol. referred to CH₄ Cod. AACSE39		✓	✓	✓	✓	✓	✓
Flex-Sensor CO₂ Cod. AACSE41		✓	✓	✓	✓	✓	✓
Flex-Sensor CO₂ Cod. AACSE47		✓	✓	✓	✓	✓	✓
Flex-Sensor H₂S Cod. AACSE35		✓	✓	✓	✓	✓	✓
Flex-Sensor NH₃ Cod. AACSE56		✓	✓	✓	✓	✓	✓
Flex-Sensor H₂ Cod. AACSE57		✓	✓	✓	✓	✓	✓

15.3 Gas sensors life

The gas sensors used in this instrument are electrochemical: thus, when the relative gas is detected, a chemical reaction takes place inside them that generates an electrical current.

The electrical current acquired by the instrument is then converted into the corresponding gas concentration. Sensor life is strongly related to the consumption of the reagents within.

Sensor characteristics diminish as the reagents are consumed and when these have been used up completely the sensor must be replaced. The sensors must be recalibrated on a regular basis to assure measuring accuracy: recalibration can only be performed by a qualified Seitron Americas service centre. [Table 15.4](#) illustrates the characteristics inherent to each sensor.

15.4 Table gas sensors life

CODE	MEASURED GAS	IDENTIFYING COLOR ⁽¹⁾	AVERAGE LIFE	RECALIBRATION
Flex-Sensor O₂ LL Cod. AACSE44	O ₂ Oxygen		48 months	Not necessary
Flex-Sensor O₂ Cod. AACSE15R	O ₂ Oxygen		>24 months	Not necessary
Flex-Sensor CO+H₂ Cod. AACSE12	CO Carbon Monoxide	Red	48 months	Yearly ⁽²⁾
Flex-Sensor CO+H₂ low range Cod. AACSE24	CO Carbon Monoxide	Red	48 months	Yearly ⁽²⁾
Flex-Sensor CO 100.000 ppm Cod. AACSE17	CO Carbon Monoxide	Purple	48 months	Yearly ⁽²⁾
Flex-Sensor CO 20.000 ppm Cod. AACSE18	CO Carbon Monoxide	Blue	48 months	Yearly ⁽²⁾
Flex-Sensor NO Cod. AACSE10	NO Nitrogen Oxide	Orange	48 months	Yearly ⁽²⁾
Flex-Sensor NO low range Cod. AACSE25	NO Nitrogen Oxide	Orange	48 months	Yearly ⁽²⁾
Flex-Sensor NO₂ Cod. AACSE14	NO ₂ Nitrogen Dioxide	White	36 months	Yearly ⁽²⁾
Flex-Sensor NO₂ low range Cod. AACSE26	NO ₂ Nitrogen Dioxide	White	48 months	Yearly ⁽²⁾
Flex-Sensor SO₂ Cod. AACSE13	SO ₂ Sulphur Dioxide	Green	36 months	Yearly ⁽²⁾
Flex-Sensor SO₂ 1.000 ppm Cod. AACSE77	SO ₂ Sulphur Dioxide		36 months	Yearly ⁽²⁾
Flex-Sensor SO₂ low range Cod. AACSE28	SO ₂ Sulphur Dioxide	Green	48 months	Yearly ⁽²⁾
Flex-Sensor C_xH_y 0-5.00% vol. referred to CH₄ Cod. AACSE39	C _x H _y Unburnt Hydrocarbons		48 months	Yearly ⁽²⁾
Flex-Sensor CO₂ 0-20% Cod. AACSE41	CO ₂ Carbon Dioxide		>48 months	Yearly ⁽²⁾
Flex-Sensor CO₂ 0-50% Cod. AACSE47	CO ₂ Carbon Dioxide		>48 months	Yearly ⁽²⁾
Flex-Sensor H₂S Cod. AACSE35	H ₂ S Hydrogen Sulfide		48 months	Yearly ⁽²⁾
Flex-Sensor NH₃ Cod. AACSE56	NH ₃ Ammonia		48 months	Yearly ⁽²⁾
Flex-Sensor H₂ Cod. AACSE57	H ₂ Hydrogen		24 months	Yearly ⁽²⁾

Notes:

(1) Colored dot on the sensor electronic board.

(2) The instrument calibration once per year is performed in a laboratory authorized to issue calibration certificates.



15.5 Expandability to 6 sensors

The S6000 Emissions Analyzer can be expanded up to 6 cells.

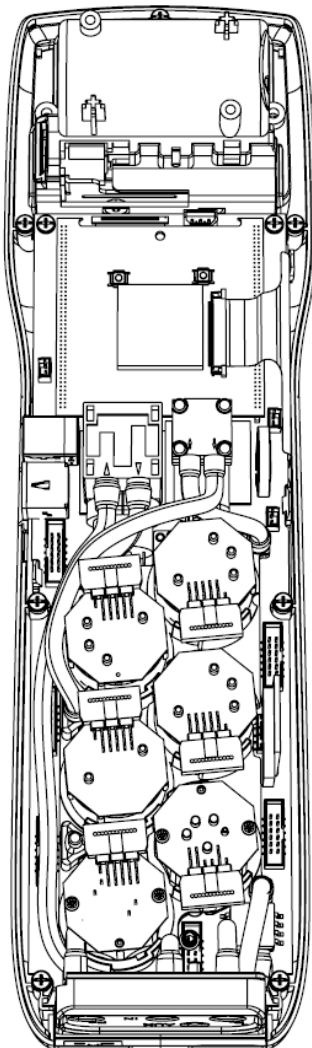

The upgrading of the number of sensors can be easily done by the user by performing the following directions:

- The expandable instruments are arranged in a way to accept up to a maximum of 6 cells.
- Identify, with the help of [paragraph 15.2 'Sensor types and relevant positioning'](#) the sensor(s) which must be added to the existing configuration (Seitron delivers all FLEX-series sensors already pre-calibrated and ready to use).
- To install the new sensors follow all the steps described in the paragraph ['MAINTENANCE'](#) under 'gas sensors replacement'.



THE INSTRUMENT AUTOMATICALLY DETECTS WHEN AN ADDITIONAL SENSOR IS INSTALLED OR HAS BEEN REMOVED. THE SCREEN 'SENSORS CONFIGURATION' ALLOWS TO ACCEPT THE NEW PROPOSED CONFIGURATION OR TO IGNORE THE CHANGE DETECTED.

IN THIS SCREEN ARE SHOWN, FOR EACH POSITION, THE FOLLOWING MESSAGES:

EXAMPLE OF AN 'NO' SENSOR IN POSITION 3 REPLACED WITH AN 'NO2' SENSOR:

NO→NO₂ A SENSOR DIFFERENT FROM THE PREVIOUS ONE HAS BEEN DETECTED.

EXAMPLE OF A NEW SENSOR INSTALLED IN POSITION 4 (PREVIOUSLY NOT PRESENT):

SO₂→□ A NEW SENSOR HAS BEEN DETECTED.

15.6 CxHy sensor for measurement of the unburnt hydrocarbons

The unburnt hydrocarbons are chemicals produced by an incomplete combustion of molecules (hydrocarbons) made of Carbon and Hydrogen.

These are usually named as HC or (better) CxHy: when this is filled with the actual values for the number of C and H atoms, the actual type of fuel is exactly defined. In case of Methane, as an example, the correct formula is CH4. In the following table is shown the cross sensitivity of the CxHy sensor when exposed to fuels different from Methane (CH4), assumed as 1.00.

GAS / VAPOR	RELATIVE RESPONSE (with respect to Methane)	GAIN ADJUSTMENT
Ethanol	0.75	1.33
Iso-Butane	0.60	1.67
Methane	1.00	1.00
Methanol	1.00	1.00
n-Butane	0.60	1.67
n-Heptane	0.45	2.22
n-Hexane	0.50	2.00
Propane	0.70	1.43

Calculation example:

Type of gas: iso-butane
 Relative response: 0.6
 Gain adjustment: 1.67
 Reading value (related to methane): 1.34

Value = reading value x gain adjustment

Example: 1.34 x 1.67 = 2.24

WARNING

Gases that contain acidic or silicone compounds (HMDS) can irreversibly damage the sensor.

15.6.1 Installing the CxHy sensor

When the CxHy (position S1 - S6) is mounted in the instrument, it is mandatory to configure the autozero by setting it at 180 seconds, in order to allow for a proper pre-heating of the sensor itself.

The instrument battery life, once the CxHy is installed, lasts 10 hours, provided no printing is made.

Configuration → Analysis → Autozero (SEE SECTION 10.2.6)

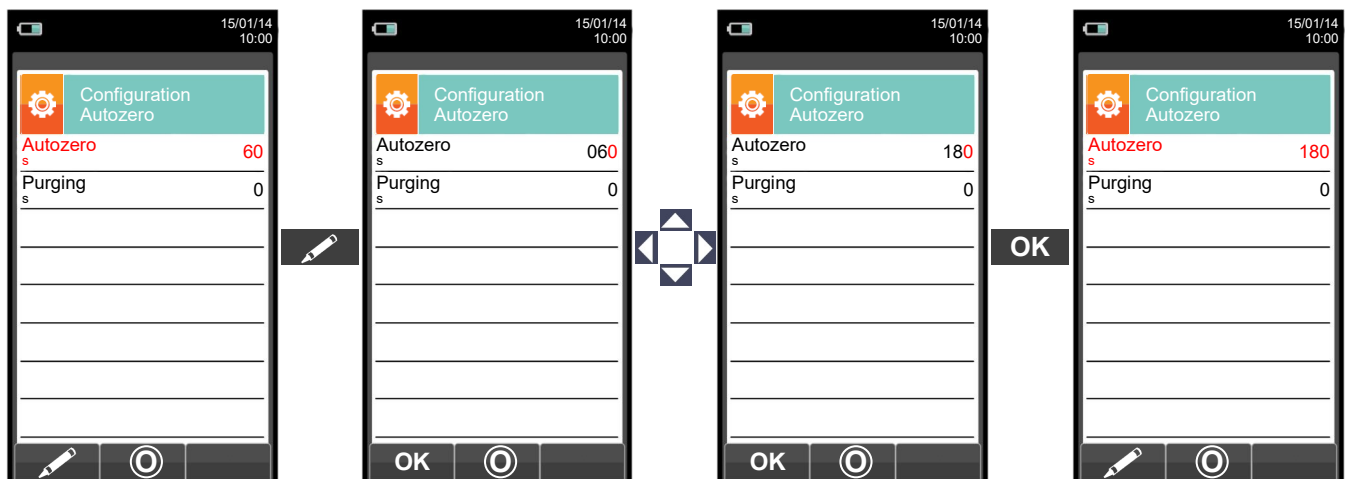
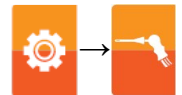

15.7 CO₂ sensor for Carbon Dioxide measurement in combustion processes

Carbon Dioxide (CO₂) is the result of combustion of an organic compound in presence of a quantity of oxygen sufficient to complete its oxidation. In nature, it is also produced by aerobic bacteria during the process of alcoholic fermentation and is the by product of respiration.

Many combustion processes are defined with 'mixed fuel' and is therefore difficult to calculate the amount of CO₂ produced. To avoid this drawback, the only way to know the amount of CO₂ produced in a combustion process with 'mixed fuel' is to measure the CO₂ with special NDIR sensors.

15.7.1 Installing the CO₂ sensor

When the CO₂ (position S1 - S6) is mounted in the S6000, it is mandatory to configure the autozero by setting it at 60 seconds, in order to allow for a proper pre-heating of the sensor itself.

Configuration → Analysis → Autozero ([SEE SECTION 10.2.6](#))

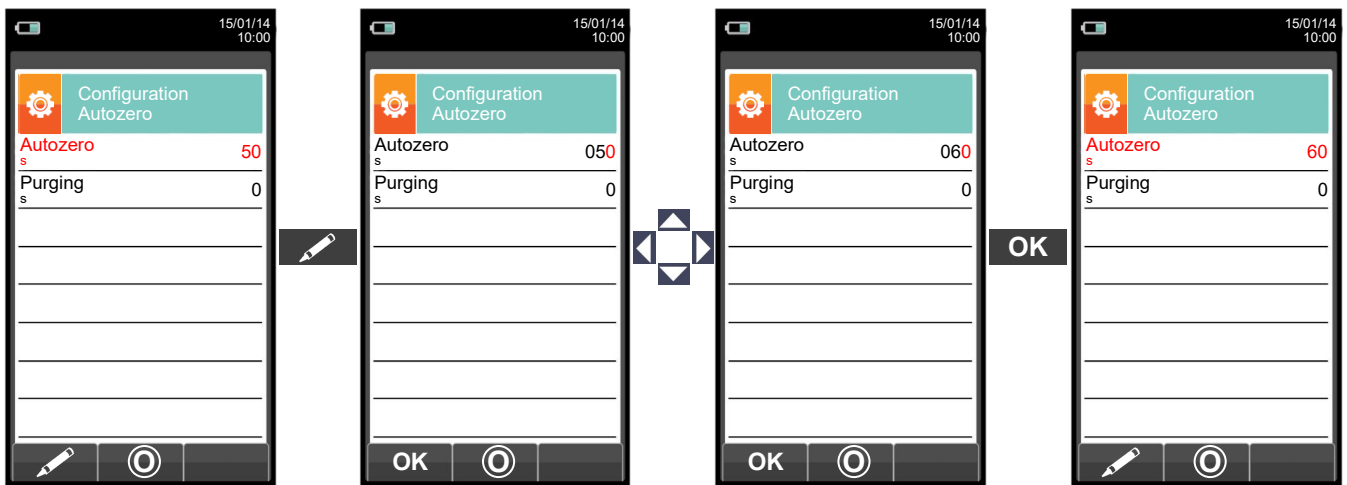
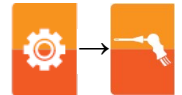

15.8 NH₃ sensor for ammonia gas measurement in combustion processes

This sensor measures the presence of ammonia (NH₃) in combustion gases and, since this gas is easily soluble in H₂O some precautions are necessary; the measure must be performed:

- For short periods of time (1-2 hours)
- Using only the flue gas sampling probe for AASX02 industrial engines as it is equipped with a filter on the tip, suitable to perform this measurement. This filter, creates a dry "pre-filtration" in order to retain the humidity that actually cancels the NH₃ content present in the fumes, making it not measurable.

The filter being inserted inside the stack is heated by the fumes and kept warm; the gas that passes through the filter does not form condensation and therefore allows an accurate measurement of ammonia. The filter inserted in the stack is called "hot filter".

In addition to the filter on the tip, in the second anti-condensation trap there is an HDPE filter that retains the dust particles but does not retain the residual moisture and therefore the ammonia. In the presence of clean fumes and in the presence of so much humidity, this second filter can be omitted, without compromising the ammonia measurement.



USE ONLY WITH THE SMOKE PROBE FOR INDUSTRIAL ENGINES COMPLETE WITH SINTERED STEEL FILTER ON THE TIP AND FILTER CARTRIDGE IN HDPE ON THE WATER TRAP (COD AASX02).

16.1 Routine maintenance

This instrument was designed and manufactured using top-quality components. Proper and systematic maintenance will prevent the onset of malfunctions and will increase instrument life altogether.

General guidelines for operations of the analyzer include the following:

- Do not expose the instrument to substantial thermal shocks before use. If this happens, wait for the temperature to return to normal working values.
- Do not extract flue gas samples directly without using a particulate/water trap.
- Do not exceed sensor overload thresholds.
- When the analysis is completed, disconnect the water trap and hoses and let the analyzer purge with clean fresh air for at least 5 to 10 minutes, or at least until the displayed parameters return to their original values in air.
- Clean the filter unit when necessary, replacing the particulate filter and blowing air through the sample probe hose to eliminate any condensate that may have formed.

Do not clean the instrument with abrasive cleaners, thinners or other similar detergents.

16.2 Preventive maintenance

At least once a year send the instrument to a SERVICE CENTER for a recalibration of the analyzer and maintenance check-up. Seitron Americas highly qualified staff is always at your disposal and will provide you with all the sales, technical, application and maintenance details required.

The service center will always return the instrument to you as new and in the shortest time possible. Calibration is performed using gases and instruments comparable with National and International Specimens. Annual servicing is accompanied by a specific calibration certificate that is a guarantee of perfect instrument performance besides being indispensable for users wishing to maintain ISO 9000 status.

16.3 Cleaning the sample probe

When you finish using the sample probe clean it thoroughly as described below before returning it to its case:

- Disconnect the sample probe from the instrument and from the water trap (Fig. a-b) then blow a jet of clean air into the hose of the probe (refer to Fig. b) to remove any residual condensate that may have formed within.

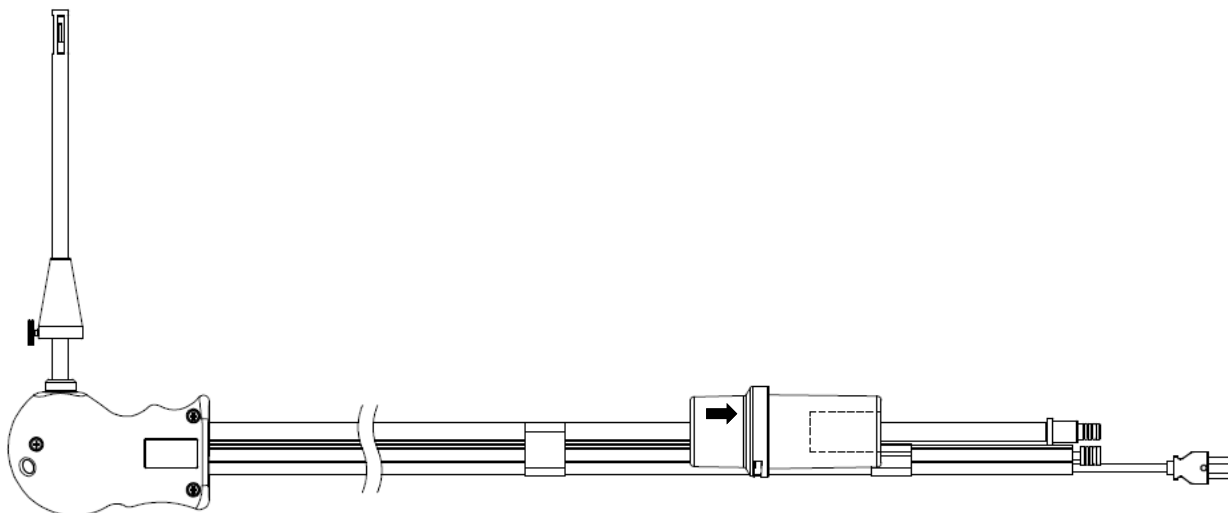

Fig. a

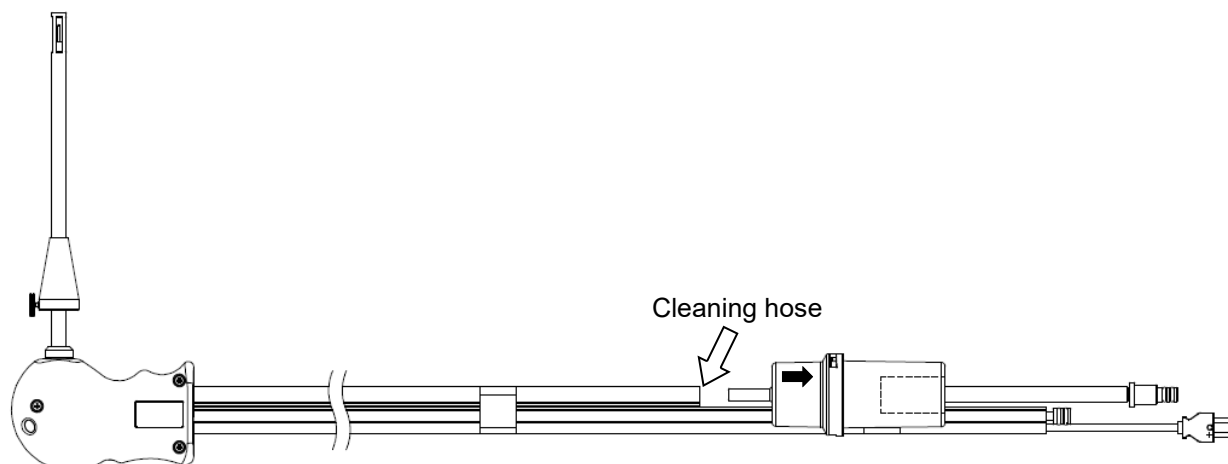
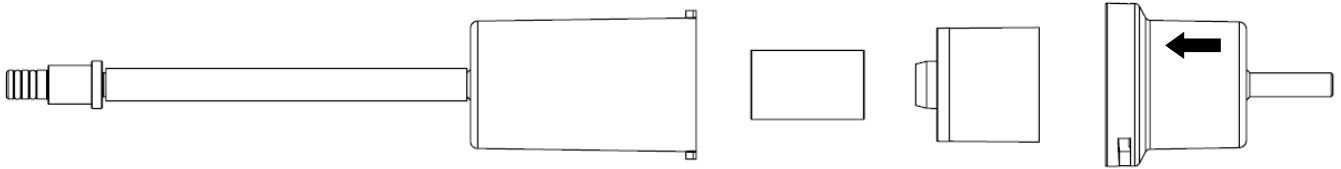

Fig. b

16.4 Maintaining the water trap / filter unit

To remove the water trap, just rotate the cover and unhook the filter holder body; remove the internal cup and then replace the filter (see figure on the side).

Clean all the filter parts using water only, dry the components and reassemble the filter.



16.5 Replacing the particulate filter

If the filter is wet or has any cracks or significant build-up of dust/ash/particulates on it, especially on the inner surface (see adjacent example), it has to be replaced immediately. In this way gas flow is not obstructed.

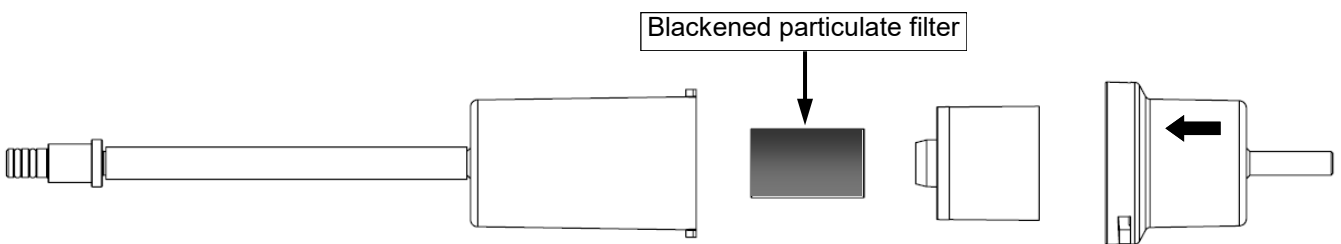

16.6 Replacing the gas sensors

The gas sensors of the instrument shall be periodically replaced (see the following table) with new or recalibrated sensors.

The user can easily perform this replacement operation according to the following instructions.

Access to sensors in positions S1 - S2 - S3 - S4

- 1 Undo the two fixing screws on the sensor compartment cover.
- 2 Extract the cover to have access to the sensor compartment.

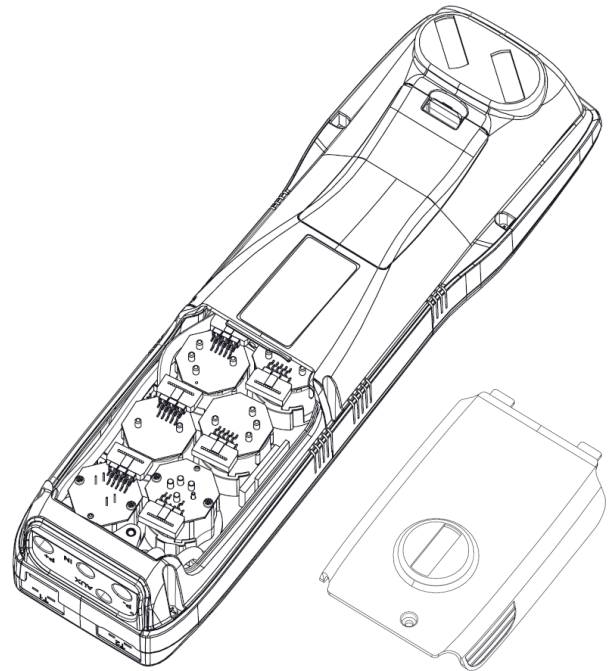
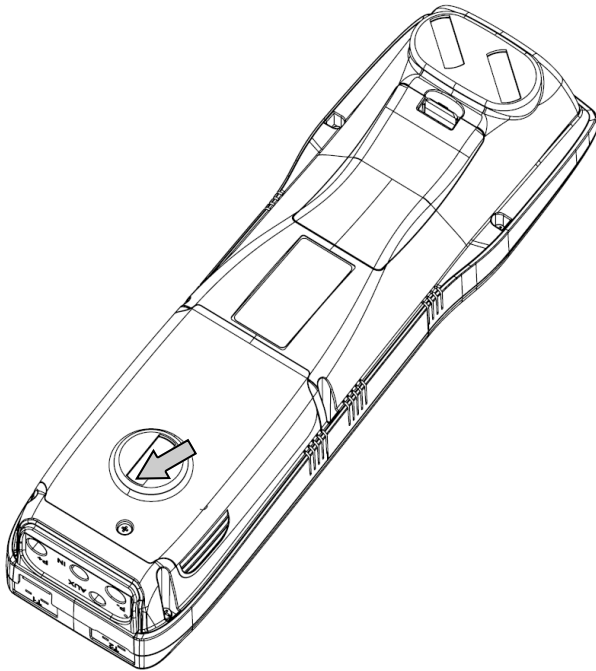

Access to sensors in positions S5 - S6

- 1 Remove the battery compartment cover.
- 2 Extract the battery pack and remove the connector.

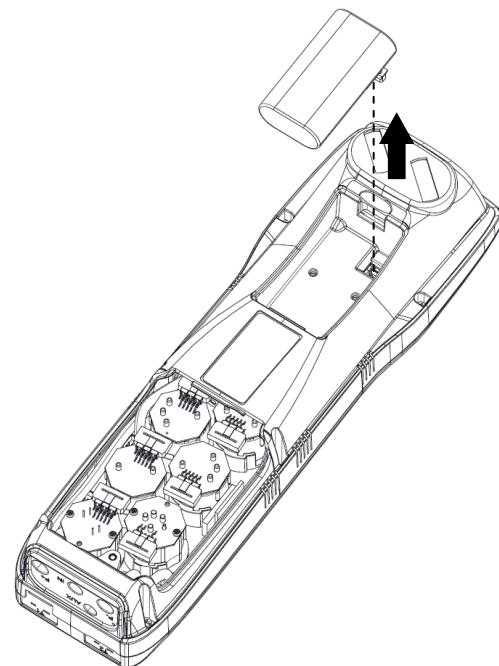
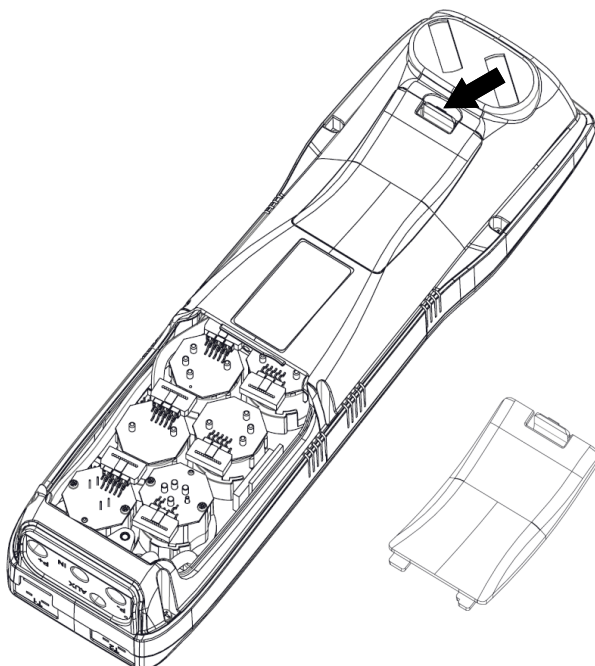

- 3** Unscrew the instrument base fastening screws and remove the base.

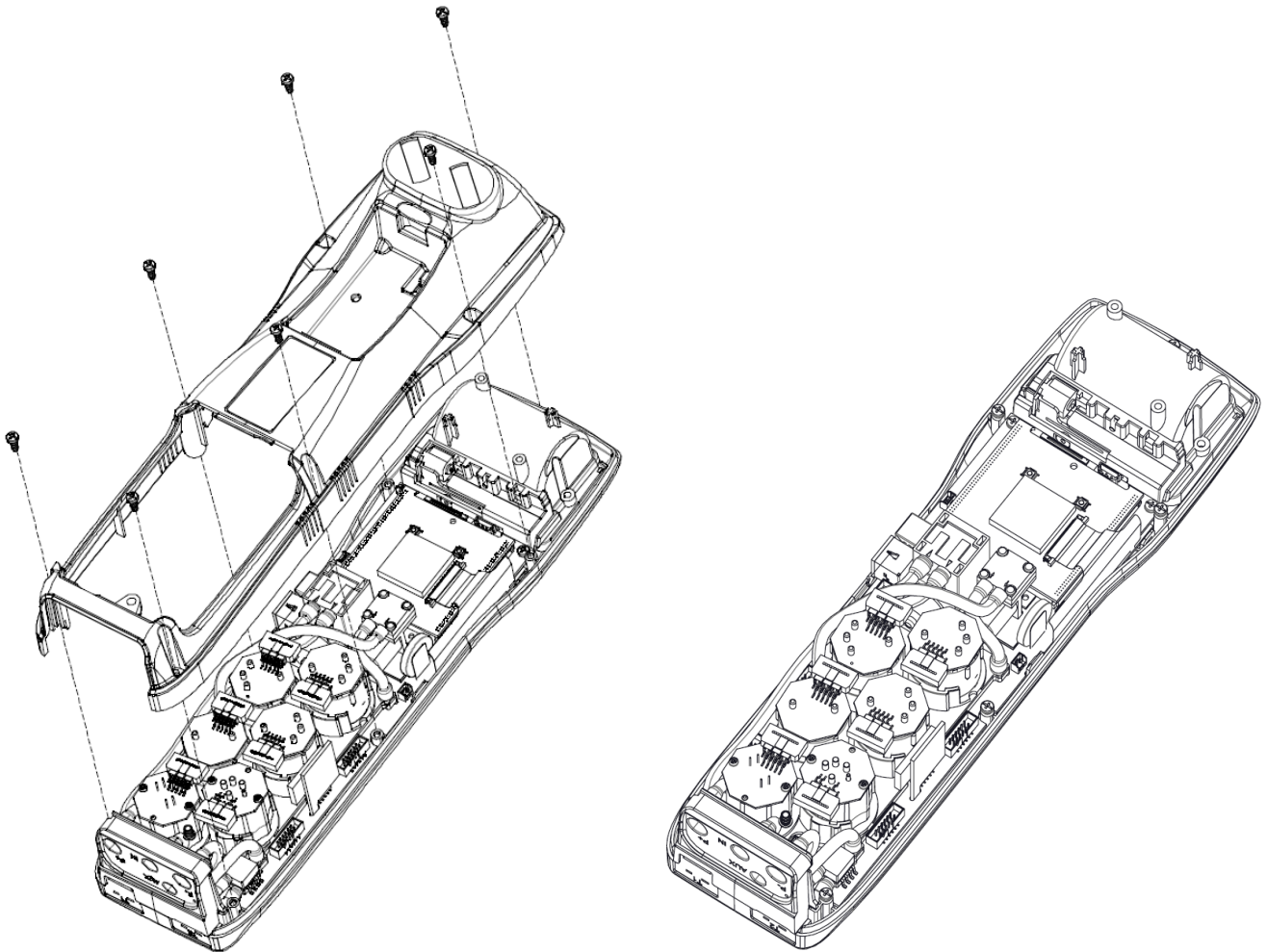

- 3 Locate the sensor to be replaced; here is an example of a connected sensor to be replaced.

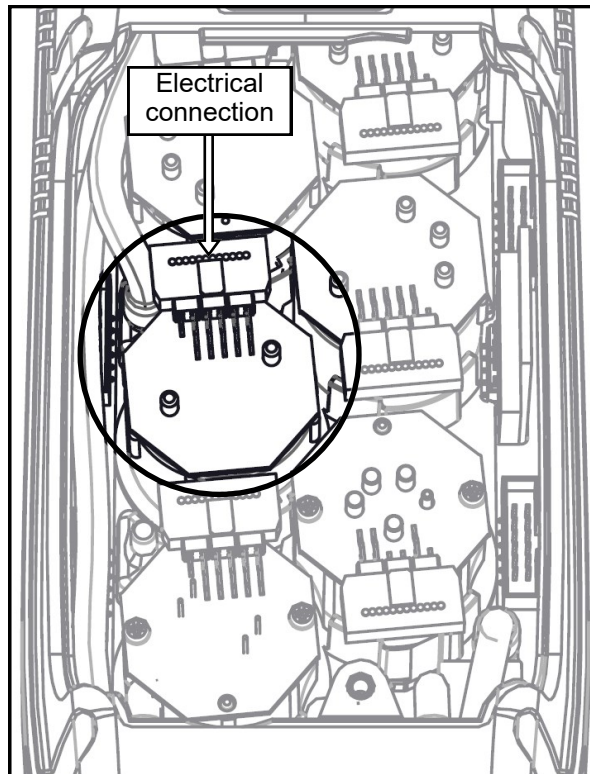

- 4 Disconnect the sensor to be replaced; here is an example of a disconnected sensor to be replaced.

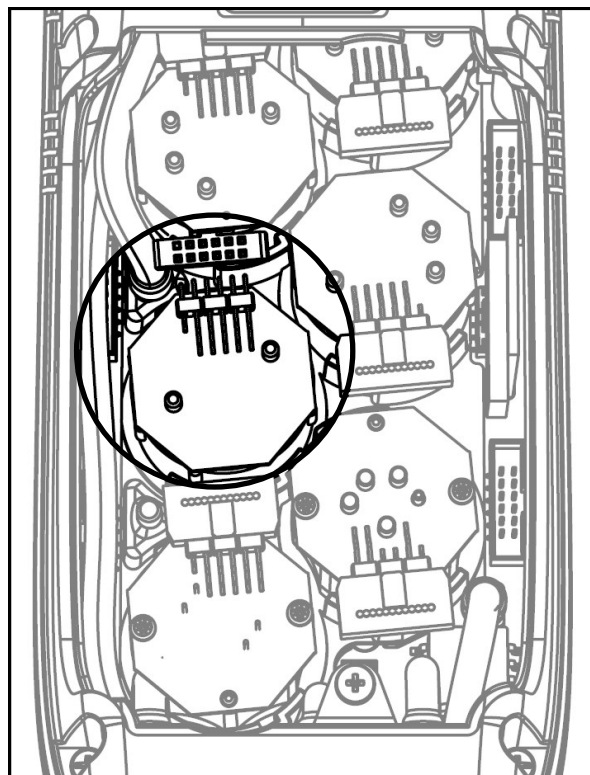

- 5 The sensor is bayonet-connected to its socket; rotate it counter-clockwise to remove it. Here is an example of a rotated sensor.



While rotating the sensor, take care not to exert any pressure on the printed circuit board mounted on the top of the sensor: exert pressure only onto the plastic body.

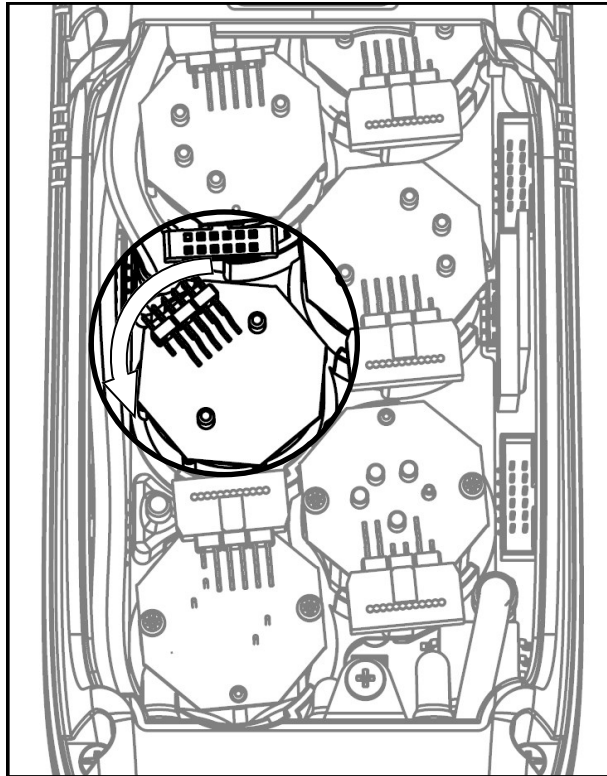

- 6 After rotating the sensor, pull it upward; here is an example of the sensor compartment with a sensor removed.

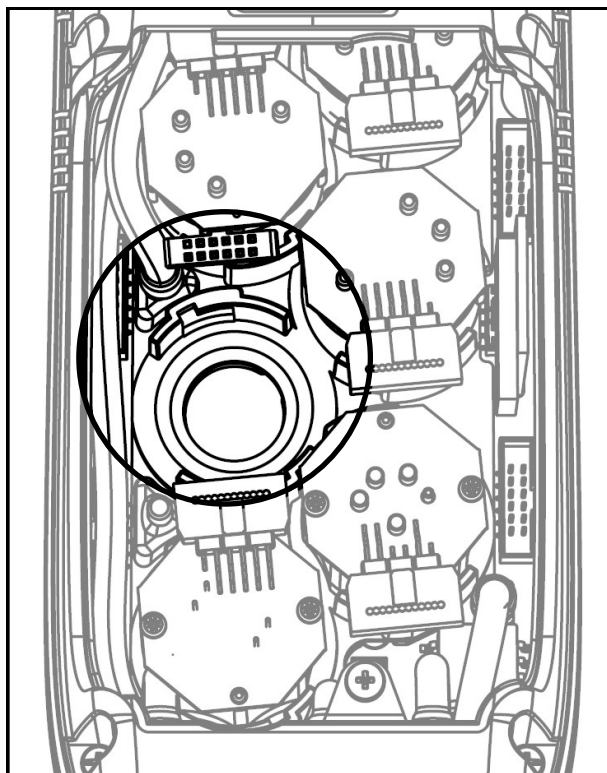

- 7 Fit the sensor again taking care the electric connection is turned outside the instrument, not inside (See point 5).

- 8 Rotate the sensor clockwise until hearing a click (See point 4).



While rotating the sensor, take care not to exert any pressure onto the printed circuit above: exert pressure onto the plastic body only.

- 9 Reconnect the sensor (See point 3).
- 10 To close the instrument logically reverse the procedure described in the section ["Access to sensors in positions S1 - S2 - S3 - S4"](#) or ["Access to sensors in positions S5 - S6"](#).

Turn on the instrument to check the new sensor works correctly through the menu "Sensor Troubleshooting".
It is normal if a newly installed sensor gives a 'current error': it is necessary to wait some time, so that the sensor polarization can settle.

The table here below shows the minimum settling time for each sensor.

CODE	MEASURED GAS	SETTLING TIME
Flex-Sensor O₂ LL Cod. AACSE44	O ₂ Oxygen	24 hours ⁽¹⁾
Flex-Sensor O₂ Cod. AACSE15R	O ₂ Oxygen	2 hours ⁽¹⁾
Flex-Sensor CO+H₂ Cod. AACSE12	CO Carbon Monoxide	2 hours ⁽¹⁾
Flex-Sensor CO+H₂ low range Cod. AACSE24	CO Carbon Monoxide	2 hours ⁽¹⁾
Flex-Sensor CO 100.000 ppm Cod. AACSE17	CO Carbon Monoxide	2 hours ⁽¹⁾
Flex-Sensor CO 20.000 ppm Cod. AACSE18	CO Carbon Monoxide	2 hours ⁽¹⁾
Flex-Sensor NO Cod. AACSE10	NO Nitrogen Oxide	48 hours ⁽²⁾
Flex-Sensor NO low range Cod. AACSE25	NO Nitrogen Oxide	48 hours ⁽²⁾
Flex-Sensor NO₂ Cod. AACSE14	NO ₂ Nitrogen Dioxide	2 hours ⁽¹⁾
Flex-Sensor NO₂ low range Cod. AACSE26	NO ₂ Nitrogen Dioxide	2 hours ⁽¹⁾
Flex-Sensor SO₂ Cod. AACSE13	SO ₂ Sulphur Dioxide	2 hours ⁽¹⁾
Flex-Sensor SO₂ 1.000 ppm Cod. AACSE77	SO ₂ Sulphur Dioxide	2 hours ⁽¹⁾
Flex-Sensor SO₂ low range Cod. AACSE28	SO ₂ Sulphur Dioxide	2 hours ⁽¹⁾
FLEX-Sensor CxHy 0-5.00% vol. referred to CH₄ Cod. AACSE39	CxHy Unburnt Hydrocarbons	1/2 hour ⁽³⁾
Flex-Sensor CO₂ 0 .. 20% vol. Cod. AACSE41	CO ₂ Carbon Dioxide	2 hours ⁽¹⁾
Flex-Sensor CO₂ 0 .. 50% vol. Cod. AACSE47	CO ₂ Carbon Dioxide	2 hours ⁽¹⁾
Flex-Sensor H₂S 500 ppm Cod. AACSE35	H ₂ S Hydrogen Sulfide	2 hours ⁽¹⁾
Flex-Sensor NH₃ 500 ppm Cod. AACSE56	NH ₃ Ammonia	24 hours
Flex-Sensor H₂ 2000 ppm Cod. AACSE57	H ₂ Hydrogen	2 hours

Notes:

- (1) 2 hours' settling time is required.
 (2) 48 hours' settling time is required; should the sensor be equipped with an external polarization battery, the settling time is reduced down to 2 hours.
 (3) 1/2-Hour settling time is required.

16.7 Replacing the battery pack AAPB01

Follow these instructions to replace the battery pack:

1 Remove the battery compartment cover.

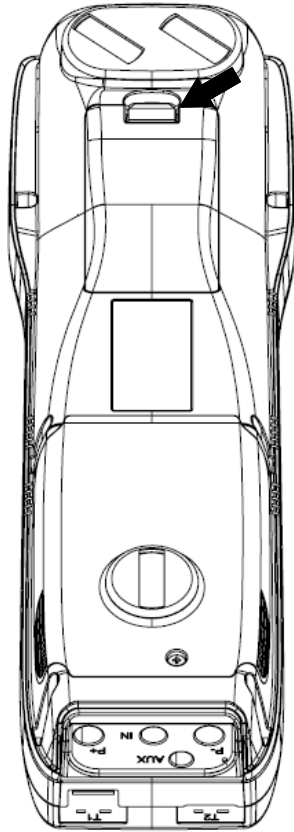

2 Extract the battery pack.

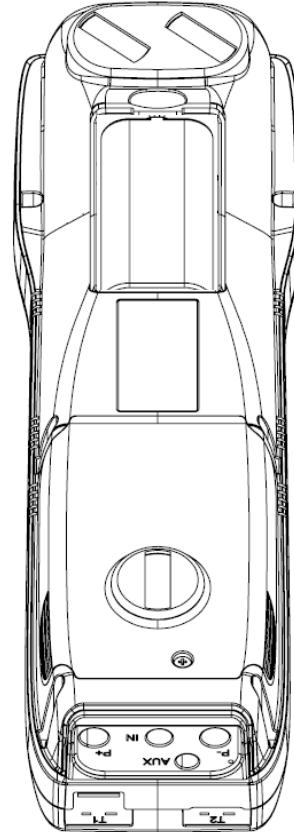

3 Remove the battery pack connector, and replace the pack with a new one following the reverse procedure described above.

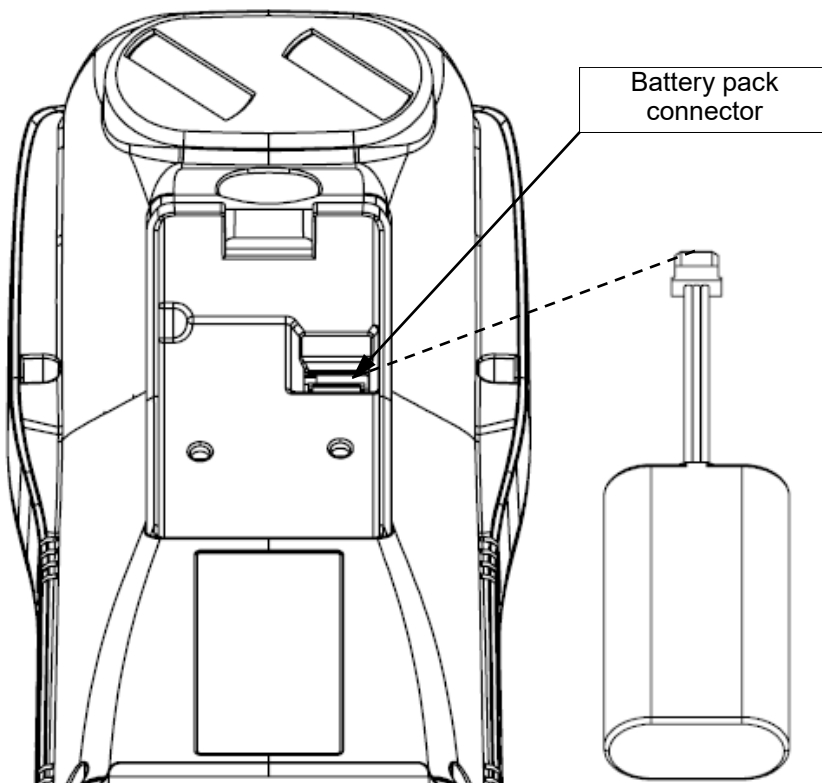

16.8 Replacing the printer paper

Follow these instructions to change the paper roll in the printer.

- 1** Lift the shiny tile, indicated by the arrow.

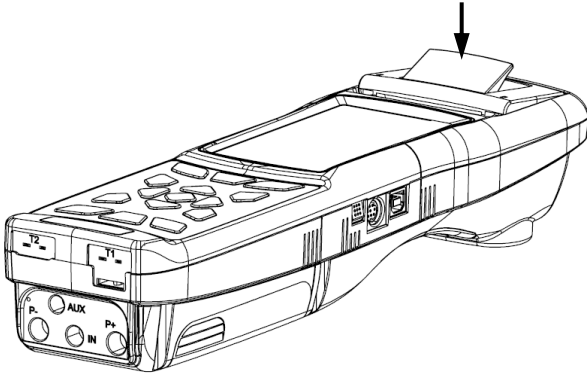

- 2** Lift the whole block of the lid completely.

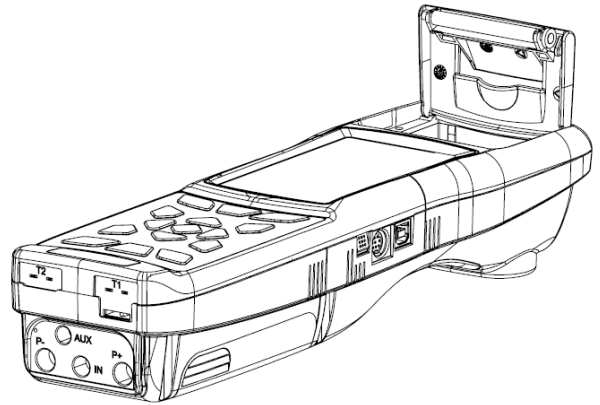

- 3** Insert the roll of printing paper as shown in the following figures.

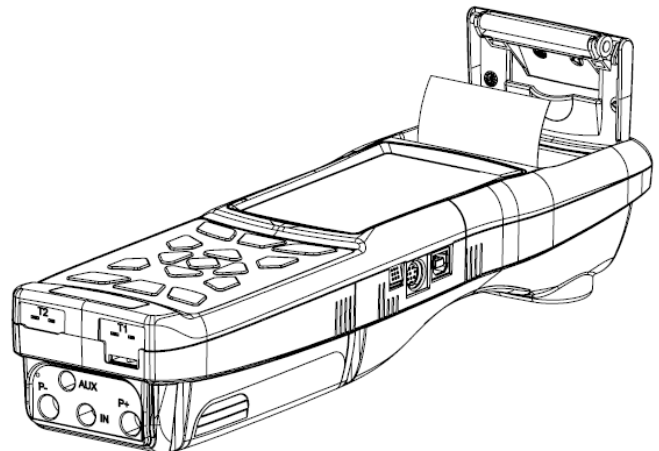
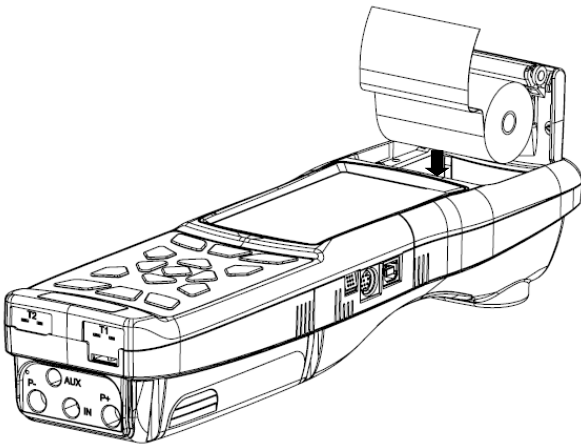

- 4** Close the whole block of the lid of the printer, pressing it lightly so as to hook it on to the device.

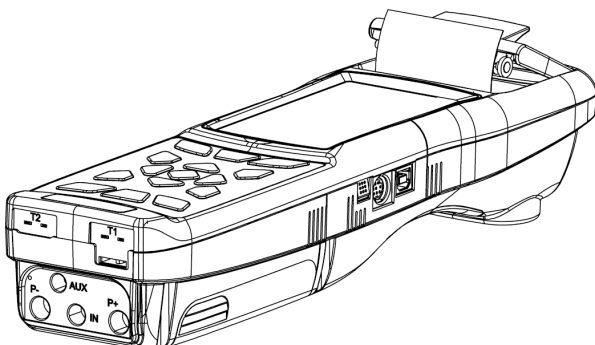

- 5** At this point it is possible to use the printer. See the parameter "Print".

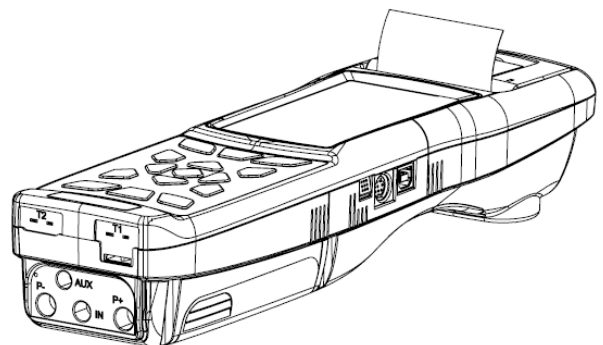

16.9 Firmware Update

The manufacturer periodically releases firmware updates of the instrument in order to correct unavoidable mistakes or improve the instrument performance or add new functions.

This update can be performed by the user by following the simple instructions below.

WARNING:

Since the firmware update could imply a different organization of the data stored in the instrument memory, maintaining the existing analysis data in the instrument is not guaranteed. Therefore it is always mandatory to make the transfer of the analysis from the instrument to the PC prior to the firmware update procedure.

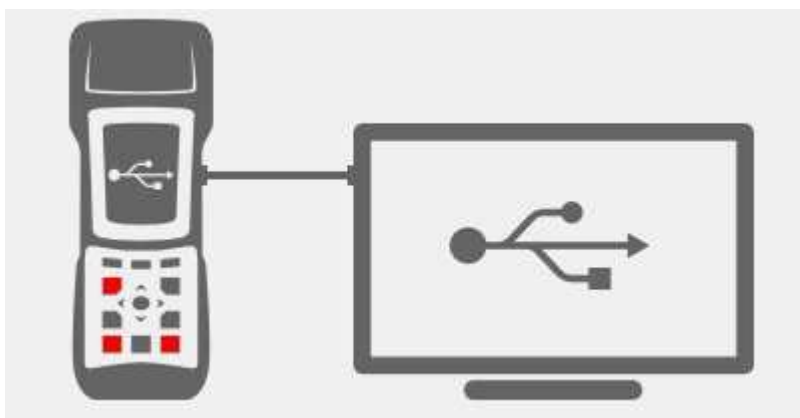

Moreover, for the same reasons, it is absolutely mandatory that the management software tool installed on the PC is updated to a version compatible with the firmware version installed on the instrument.

Instructions to update the combustion analyzer with a new firmware:



1. Log in to the website www.seitronamericas.com and download the firmware file available in the "combustion analyzers" section. This file is in a compressed version .zip.
2. Unzip the file thus obtaining the contents of the .zip file (extension .srec)
3. Plug in the analyzer to the PC via the USB cable
4. Hold down the three red buttons on the analyzer for at least 10 seconds
5. Release only the power on/off button
6. The analyzer will be recognized by the operating system as a portable device drive
7. Release the remaining two buttons
8. Copy the firmware file (extension .srec) to the directory of the analyzer
9. Wait till the end of the file copy operation
10. The file copy directory will be closed and the analyzer will restart
11. The analyzer is now updated, it can be powered off and it can be unplugged from the PC

17.1 Troubleshooting guide

SYMPTOM	PROBABLE CAUSES AND REMEDIES
The instrument does not work at all. When the On/Off pushbutton is pressed the instrument does not come on.	<ul style="list-style-type: none"> a. Keep the On/Off key depressed for at least 2 seconds. b. The battery is low; connect the battery charger to the instrument. c. The battery pack is not connected to the instrument; remove the cover from the battery compartment and connect the connector of the battery pack to the outlet on the printed circuit board. d. The instrument is faulty: send it to a service center.
The battery symbol  is empty on the inside.	The batteries are low. The instrument will remain on for a couple of minutes after which it will switch off; connect the battery charger.
After auto-calibration is complete the sensor diagnostics screen appears and gives an error for one or more cells.	<ul style="list-style-type: none"> a. Auto-calibration took place while the flue gas was being sampled. b. The O₂ sensor is faulty, is not connected correctly or is not connected at all. Check the above points, also referring to sections 10.6.2 - 10.7.1 - 15.0. c. The sensor was not allowed the necessary adjustment time or the instrument was left with a low battery for too long.
A pressure sensor error is shown in the pressure/draft screen.	There is a calibration problem. Send the instrument to a service center.
The analysis screen gives a flue gas temperature (Tf) error.	<ul style="list-style-type: none"> a. The thermocouple is not connected; connect the thermocouple to the analyzer. b. The sensor has been exposed to temperatures greater or lower than its operating temperature range. c. The thermocouple is faulty. Send the complete probe to a service center.
The following symbol "----" appears on the analysis screen.	The instrument is not able to calculate a numerical value based on the flue gas analysis conducted. The "----" are replaced by numbers when the analyzer detects valid combustion data.
"Max. Lim." or "Min. Lim" appears on the analysis screen.	The relative sensor is detecting a value that is beyond the analyzer's measuring range. "Max. Lim." or "Min. Lim." are replaced by numbers when the instrument reveals values that are within the measuring range.
The sample pump sounds as though it is running slowly, tends to stop or does not even start.	<ul style="list-style-type: none"> a. Sample flow is obstructed. Check that the water filter is clean and that it is not completely soaked. Also check that the hose connected to the probe is not crushed. b. Sample intake flow is obstructed. Check that the particulate filter is clean. c. The pump is not connected as it should be. Remove the rear flap and check that the pump's electrical connector is connected to the printed circuit board. d. Pump is faulty. Replace the pump unit. e. Pump is disabled. The key combination   has been pressed. To re-enable the pump, switch off the instrument and then switch it on again.

Troubleshooting guide

SYMPTOM	PROBABLE CAUSES AND REMEDIES
The rear lighting of the display is not on.	The backlighting LED's are faulty. Contact the nearest service center to replace the display.
The battery operating time is less than 9 hours.	<ul style="list-style-type: none"> a. Battery capacity is limited by low temperatures. To achieve a longer battery life it is recommended to store the instrument at higher temperatures. b. The battery pack is old. Battery capacity tends to diminish with age. If battery life has become unacceptable, replace the battery pack:
The values shown in the analysis screen are not reliable.	<ul style="list-style-type: none"> a. Sensor/s is/are faulty. Check that the sensors are installed correctly by accessing the sensor diagnostics menu. b. The sample probe connection presents a leak. Check all joints and the conditions of the hose. c. Pump is faulty. Replace the pump unit. d. The instrument is faulty: Send it to a service center for repair. e. Analyzer needs to be recalibrated.
During the tightness test a "sensor error" is reported.	Check for the correct connection of the hose to the positive pressure input.

18.1 Spare parts

CODE	DESCRIPTION
AAPB01	Li-Ion 7,2V 2,4Ah battery pack
AARC10	Inerasable thermal paper roll for printer, h=2.3" Diam.=1.4"
AACADX005	Dummy sensor
AACSE44	FLEX-Sensor O ₂ , long life, pre-calibrated and interchangeable 4-Year LONG LIFE Sensor
AACSE15R	FLEX-Sensor O ₂ pre-calibrated and interchangeable (Standard 2-Year O ₂ sensor)
AACSE12	FLEX-Sensor CO+H ₂ , pre-calibrated and interchangeable
AACSE10	FLEX-Sensor NO/NO _x , pre-calibrated and interchangeable
AACSE14	FLEX-Sensor NO ₂ , pre-calibrated and interchangeable
AACSE13	FLEX-Sensor SO ₂ , pre-calibrated and interchangeable
AACSE17	FLEX-Sensor CO 100.000 ppm, pre-calibrated and interchangeable
AACSE18	FLEX-Sensor CO 20.000 ppm, pre-calibrated and interchangeable
AACSE19	FLEX-Sensor for combustible gas leak (Methane)
AACSE39	FLEX-Sensor C _x H _y related to CH ₄ , pre-calibrated and interchangeable
AACSE24	FLEX-Sensor CO+H ₂ low range, pre-calibrated and interchangeable
AACSE25	FLEX-Sensor NO low range, pre-calibrated and interchangeable
AACSE26	FLEX-Sensor NO ₂ low range, pre-calibrated and interchangeable
AACSE28	FLEX-Sensor SO ₂ low range, pre-calibrated and interchangeable
AACSE41	FLEX-Sensor CO ₂ 0-20% v/v, pre-calibrated and interchangeable
AACSE47	FLEX-Sensor CO ₂ 0-50% v/v, pre-calibrated and interchangeable
AACSE35	FLEX-Sensor H ₂ S, pre-calibrated and interchangeable
AACSE56	FLEX-Sensor NH ₃ 0-500 ppm, pre-calibrated and interchangeable
AACSE57	FLEX-Sensor H ₂ 0-2000 ppm, pre-calibrated and interchangeable
AAC SE77	FLEX-Sensor SO ₂ compliant with J57-2017, pre-calibrated and interchangeable

18.2 Accessories

CODE	DESCRIPTION
AAKA01	AC Power Adapter Kit For ALL Analyzers (Power adapter w/ US plug adapter + USB A / USB B cable)
AACR10	Rigid plastic case
AAZN01	Back-pack
AACCT01	Case with shoulder strap
AACDP02	Deprimometer for Draft test
AACSO01	Probe for measuring the ionization current
AASA08	Outdoor Primary Air Temp TcK Probe for Condensing Systems (8") w/ 6.5' (2 m) cable
AASF61A	7 inches gas probe, maximum working temperature: 752°F, with 6.6 ft. cable
AASF51A	7 inches gas probe, maximum working temperature: 752°F, with 6.6 ft. cable
AASF62A	11.8 inches gas probe, maximum working temperature: 1112°F, with 9.8 ft. cable
AASF52A	11.8 inches gas probe, maximum working temperature: 1112°F, with 6.6 ft. cable
AASF65A	29.5 inches gas probe, maximum working temperature: 1472°F, with 9.8 ft. cable
AASF66A	39 inches gas probe, maximum working temperature: 2192°F, with 9.8 ft. cable
AASL05A	7 inches flexible gas probe, 266°F extended temperature range, with 6.6 ft. cable
AASX01	Gas sampling probe for average CO, 7 inches with 6.6 ft. cable
AASX02	Probe for industrial motors, 29.5 inches with 9.8 ft. cable
AASP01	Protective screen for gas sampling probe
AACTA03	Particulate/water filter assembly
AACTA03A	Particulate/water filter assembly with steel pipe and connector
AAEX01	10ft' (3m) Extension Hose for all gas analyzer probes
AASM06	Rubber protecting cover.
AATT01	'L' shaped Pitot Tube (without Tc-K thermocouple): length 7 inches - external \varnothing 0.2" Supplied with two silicone tubes with length 6.6 ft.
AATT03	36" (900mm) S-Type Pitot Tube for Gas Velocity
AATT02	'L' shaped Pitot Tube (without Tc-K thermocouple): length 31.5" - external \varnothing 0.2" Supplied with two silicone tubes with length 6.6 ft.
AAPM02	Manual pump kit for smoke measurement.
AASW08	Configuration software kit (USB + PC cable).
AAUA01	Adapter cable USB-A / USB-B.
AASC01	Ambient CO probe
SP4500	S-Probe attachment for forklifts and small engines

18.3 Service Centers

Headquarters:

Seitron Americas Inc.

4622 Street Rd. Trevoise PA

19053 - USA

Tel.: (215) 660-9777

Fax.: (215) 660-9770

E-mail: service@seitronamericas.com

<http://www.seitronamericas.com>

Data Management with “Seitron Smart Analysis” APP



SCAN THE QR CODE USING SEITRON APP “Seitron Smart Analysis”, TO DOWNLOAD THE ACQUIRED DATA.

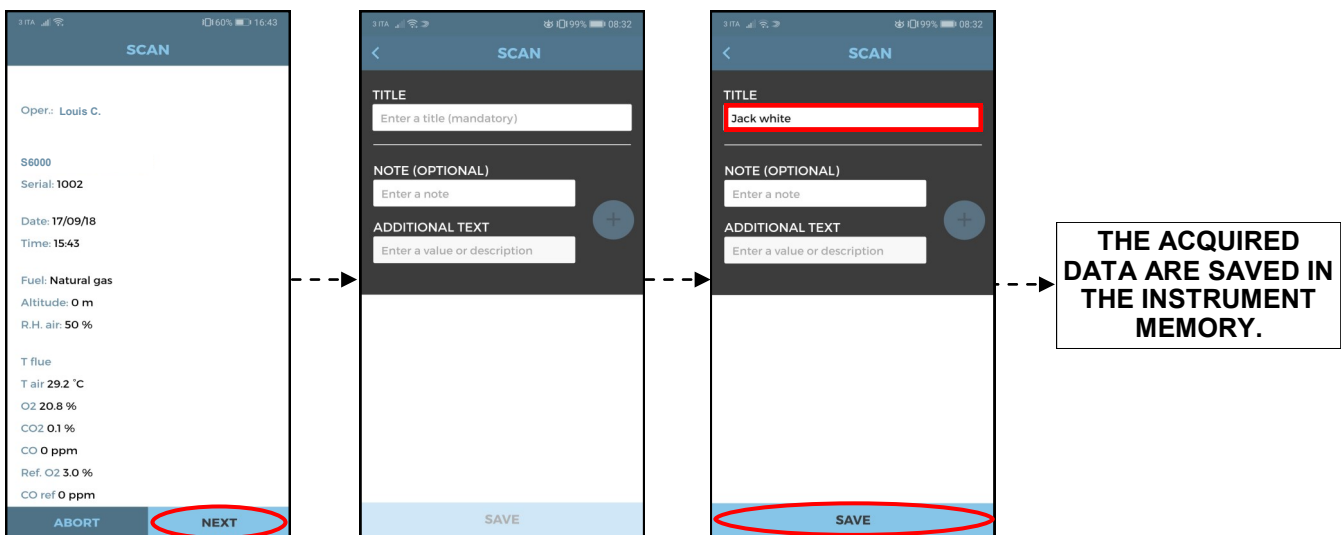

APP settings.

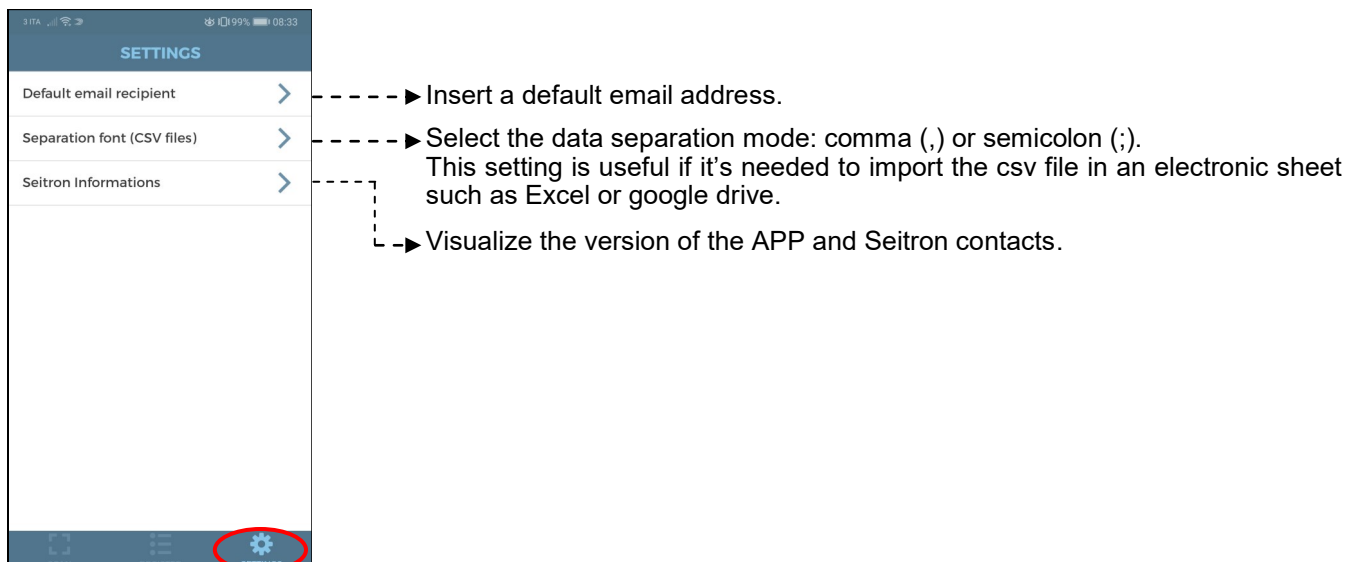

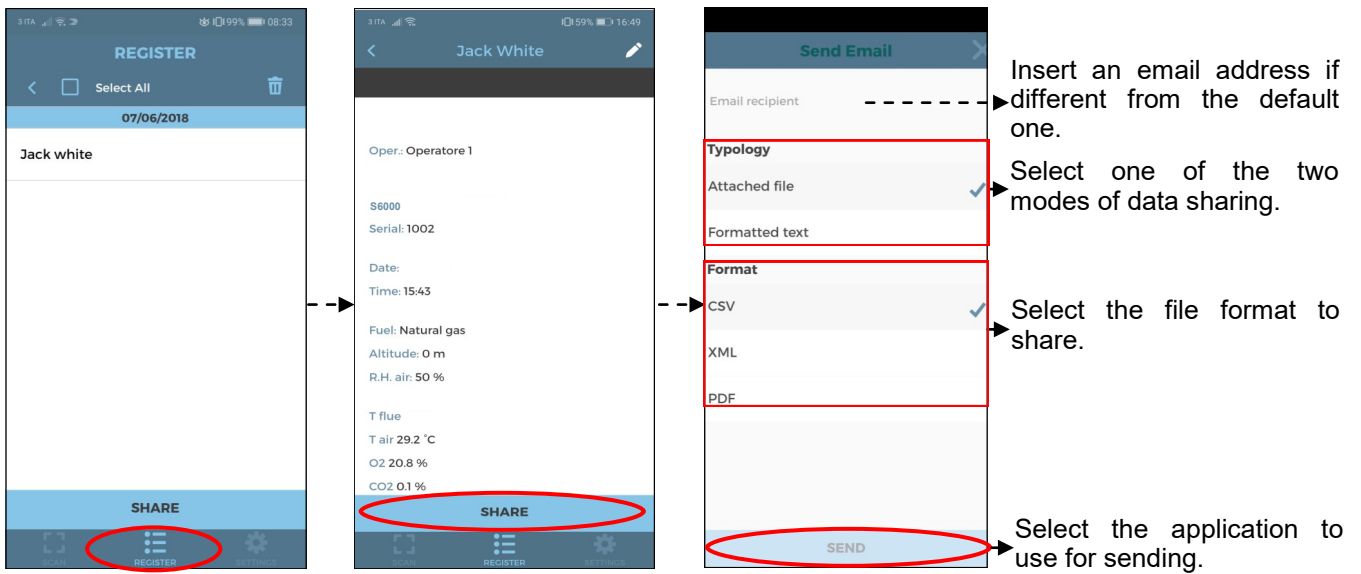

Example of the exported csv file and imported in an excel file:

S6000		
Serial number	1100	
Date	15/12/2017	
Time	12:00	
Fuel	Natural gas	
Altitud.	0.000000m	
Air humidity	50%	
O2	15.7%	
CO	23ppm	
CO2	2.9%	
T smoke	100.6°C	
T air	27.0°C	
ηs	90.0%	
NO	0.000mV	
CO-SEN	258.270mV	
O2	1.131.867mV	
I sen	0.000uA	
I sen	0.000uA	
I sen	100.346uA	
T az	22.5°C	
ΔT	73.6°C	
Qs	10.0%	
λ,n	4.01	
Air excess	4.01	
ηc	0.0%	
ηt	90.0%	
Qs (PCS)	10.0%	
Qt (PCS)	10.0%	
ηs (PCS)	90.0%	
ηc (PCS)	0.0%	
ηt (PCS)	90.0%	
NO	0ppm	
NOx	0ppm	
CO (0.0%)	0ppm	
NO (0.0%)	0ppm	
NOx (0.0%)	0ppm	
Draught	4.5Pa	

Example of Total analysis report.

COMPANY Ltd.
Park Road, 9
Tel.02/12345678

Oper.: John Smith

Sign.: _____

S6000
Serial: 999989

Memory: 01
Analysis: Average
Date: 04/04/14
Time: 10.30

Fuel: Natural gas
Altitude: 0 m
R.H. air: 50 %

O ₂	15.7 %
CO ₂	2.9 ppm
λ,n	4.01
T flue	100.6 °C
T air	27.0 °C
ΔT	73.6 %
QS	10.0 %
η _S	90.0 %
η _C	0.0 %
η _T	90.0 %
CO	23 ppm
NO	14 ppm
NO _x	15 ppm
Ref. O ₂ :	0.0 %
CO ref	92 ppm
Ref. O ₂ :	0.0 %
NO ref	56 ppm
Ref. O ₂ :	0.0 %
NO _x ref.:	60 ppm
Draft	4.5 Pa
T ext.	10.0 °C

Note: -----

Analysis: 1
04/03/16 10.00

O ₂	15.7 %
CO ₂	2.9 %
λ,n	4.01
T flue	100.4 °C
T air	27.0 °C
ΔT	73.4 °C
QS	10.0 %
η _S	90.0 %
η _C	0.0 %
η _T	90.0 %
CO	23 ppm
NO	14 ppm
NO _x	15 ppm
Ref. O ₂ :	0.0 %
CO ref	92 ppm
Ref. O ₂ :	0.0 %
NO ref	52 ppm
Ref. O ₂ :	0.0 %
NO _x ref.:	56 ppm
Tiraggio	4.5 Pa
T ext.	10.0 °C

Analysis: 2
04/03/16 10.15

O ₂	15.7 %
CO ₂	2.9 %
λ,n	4.01
T flue	100.6 °C
T air	27.0 °C
ΔT	73.6 °C
QS	10.0 %
η _S	90.0 %
η _C	0.0 %
η _T	90.0 %
CO	23 ppm
NO	14 ppm
NO _x	15 ppm
Ref. O ₂ :	0.0 %
CO ref	92 ppm
Ref. O ₂ :	0.0 %
NO ref	56 ppm
Ref. O ₂ :	0.0 %
NO _x ref.:	60 ppm
Draft	4.5 Pa
T ext.	10.0 °C

Analysis: 3
04/03/16 10.20

O ₂	15.7 %
CO ₂	2.9 %
λ,n	4.01
T flue	100.8 °C
T air	27.0 °C
ΔT	73.8 °C
QS	10.1 %

η _S	89.9 %
η _C	0.0 %
η _T	89.9 %
CO	23 ppm
NO	14 ppm
NO _x	15 ppm
Ref. O ₂ :	0.0 %
CO ref	92 ppm
Ref. O ₂ :	0.0 %
NO ref	56 ppm
Ref. O ₂ :	0.0 %
NO _x ref.:	60 ppm
Draft	4.5 Pa
T ext.	10.0 °C

Example of Full analysis report.

```

COMPANY Ltd.
Park Road, 9
Tel.02/12345678

Oper.: John Smith

Sign.: _____

S6000
Serial: 999989

Memory: 01
Analysis: Average
Date: 04/04/14
Time: 10.30

Fuel: Natural gas
Altitude: 0 m
R.H. air: 50 %

O2                15.9 %
CO2                2.8 ppm
λ,n               4.18
T flue            80.6 °C
T air             26.9 °C
ΔT                53.7 %
Qs                7.6 %
ηs                92.4 %
ηc                0.0 %
ηt                92.4 %
CO                 27 ppm
NO                 11 ppm
NOx                12 ppm
Ref. O2:          0.0 %
CO ref            113 ppm
Ref. O2:          0.0 %
NO ref            46 ppm
Ref. O2:          0.0 %
NOx ref.:         50 ppm
Draft              4.5 Pa
T ext.            10.0 °C

Note: -----
-----
-----
-----
-----
-----
-----

```

Example of Partial Paper print-out.

```

Date: 04/04/14
Time: 10.15

Fuel: Natural gas
Altitude: 0 m
R.H. air: 50 %

O2                15.7 %
CO2                2.9 ppm
λ,n               4.01
T flue            95.4 °C
T air             26.9 °C
ΔT                68.5 %
Qs                9.3 %
ηs                90.7 %
ηc                0.0 %
ηt                90.7 %
CO                 23 ppm
NO                 13 ppm
NOx                14 ppm
Ref. O2:          0.0 %
CO ref            92 ppm
Ref. O2:          0.0 %
NO ref            52 ppm
Ref. O2:          0.0 %
NOx ref.:         56 ppm
Smoke              4.5 Pa
T ext.            10.0 °C

Smoke:    3 1 2
Aver n°:  2

```

Example of Draft Paper print-out.

```

COMPANY Ltd.
Park Road, 9
Tel.02/12345678

Oper.: John Smith

Sign.: _____

S6000
Serial: 999989
Memory: 01

Date: 04/04/14
Time: 10.30

Draft              4.5 Pa
T ext.            10.0 °C

Note: -----
-----
-----
-----

```

Example of ambient CO Paper print-out.

```

COMPANY Ltd.
Park Road, 9
Tel.02/12345678

Oper.: John Smith

Sign.: _____

S6000
Serial: 999989
Memory: 01

Date: 04/04/14
Time: 10.30

CO amb           0 ppm

Note: -----
-----
-----
-----
    
```

Example of Smoke Paper print-out.

```

COMPANY Ltd.
Park Road, 9
Tel.02/12345678

Oper.: John Smith

Sign.: _____

S6000
Serial: 999989
Memory: 01

Date: 04/04/14
Time: 10.30

Fuel: Diesel

Smoke:   3  1  2
Aver. n°:   2

Note: -----
-----
-----
    
```

Example of Velocity Paper print-out.

```

COMPANY Ltd.
Park Road, 9
Tel.02/12345678

Oper.: John Smith

Sign.: _____

S6000
Serial: 999989
Memory: 01

Date: 04/04/14
Time: 10.30

Gas: Air

V air           9.11 km/h
Density         1.199 kg/m³
Altitude        0 ft
T air           25.3 °C
K Pitot         0.980

Note: -----
-----
-----
    
```

Coefficients of the fuels and Formulas

The following chart lists the coefficients of the memorised fuels, used for calculating losses and efficiencies. Details of the coefficients of the fuels:

Coefficients for calculating combustion efficiency								
Fuel	A1 USA	B	CO ₂ t (%)	PCI (KJ/Kg)	PCS (KJ/Kg)	M air (Kg/Kg)	M H ₂ O (Kg/Kg)	V dry gas (m ³ /Kg)
Natural Gas	0.0280	0.0090	11.70	50050	55550	17.17	2.250	11.94
#2 Oil	0.0305	0.0066	15.70	42900	45700	14.30	1.136	10.34
#4 Oil	0.0306	0.0066	15.80	41100	43500	13.80	0.973	10.06
#6 Oil	0.0346	0.0048	16.00	39800	42197	13.61	0.981	9.97
Diesel	0.0305	0.0066	15.70	42900	45700	14.30	1.136	10.34
Wood/Pellets 8%	0.0354	0.0071	19.01	18150	19750	6.02	0.660	4.58
Bagasse	0.0395	0.0219	20.45	6950	8834	2.50	0.779	1.93
Coal	0.0320	0.0000	18.60	31400	32300	10.70	0.370	8.14
Biogas	0.0353	0.0091	17.33	17800	19800	6.08	0.830	4.55
Bio-Fuel 5%	0.0305	0.0066	15.70	42600	45400	14.22	1.133	10.64
Butane	0.0277	0.0073	14.00	45360	49150	15.38	1.548	10.99
Propane	0.0277	0.0073	13.70	45950	49950	15.61	1.638	11.11
B20	0.0313	0.0052	15.52	41806	44620	14.04	1.152	13.89

- **CO₂ t:** The value of CO₂ generated by combustion in stoichiometric condition, i.e. without excess Oxygen and therefore maximum.
- **A1, B:** Also please have a look at the Siegert formulas (in the following).
A1 is the parameter in the Siegert Formula when the O₂ measurement is available.
A2 is used when the CO₂ measurement is available.
Note: - Please also consider that in the U.S. usually the A1 parameter is the same as the 'european' A1 BUT divided by 2.

Flue gas heat losses are calculated from measured oxygen content according to the relationship:

$$q_A = (t_A - t_L) \times \left(A1 \frac{21}{21 - O_2} + B \right)$$

Flue gas heat losses are calculated from measured carbon dioxide content according to the relationship:

$$q_A = (t_A - t_L) \times \left(A1 \frac{CO_2t}{CO_2} + B \right)$$

Air index is calculated with the formula:

$\lambda = 21 / (21 - O_2)$, where O₂ is the oxygen residual concentration in the combustion smokes.

Air excess is calculated with the formula:

$$e = (\lambda - 1) * 100$$

- **CO conv:** Conversion coefficient from ppm to mg/KWh. It can be expressed as a function of the gas density (CO in this case) and the volume of the dry smoke.
- **NO conv:** Same as CO conv, but for NO.
- **NOx conv:** Same as CO conv, but for NOx.
- **SO2 conv:** Same as CO conv, but for SO2.
- **PCI:** Potere Calorifico Inferiore. Italian for LHV (Lower Heating Value).
- **PCS:** Potere Calorifico Superiore. Italian for HHV (Higher Heating Value).
- **m H₂O:** Mass of the air produced (per each Kg of fuel) in the combustion in stoichiometric condition.
- **m Air:** Mass of the air needed for combustion in stoichiometric condition.
- **V g.d.:** Volume of dry smokes produced in the combustion.

Instructions for accurate testing

In order to achieve a certain degree of accuracy when conducting flue gas analysis, the following should be respected:

- the boiler being checked should be running in steady state conditions.
- the flue gas analyzer should be switched on at least 3 minutes before testing (time to auto-calibrate) with the probe located in fresh air.
- the point in which the probe is inserted for analysis has to be at a distance of approximately twice the stack diameter or, alternatively, as directed by the boiler manufacturer.
- the water trap should be completely empty and positioned vertically.
- before switching off the instrument, extract the probe and wait at least 3 minutes (the CO value has to drop below 10 ppm).
- Before returning the instrument to its place, clean the water trap and relative hose; if water is present in the hose clean the latter by blowing inside.

Optional measures list:

MEASURE	DEFINITION
λ, n	Air index (defined as λ , sometimes also indicated as n).
e	Air excess. Expressed as a percentage according to the formula in the appendix B, is the ratio between the volume of air actually entering the combustion chamber and the one theoretically needed.
ΔT	Differential temperature: It is the difference between the smoke temperature and the air combustion temperature.
Q_s (LHV)	Stack losses in relation to the Lower Heating Value: It is the percentage of dissipated heat through the stack referred to the lower heating value (LHV)
Q_s (HHV)	Stack losses in relation to the Higher Heating Value: It is the percentage of dissipated heat through the stack referred to the higher heating value (HHV)
η_s (LHV)	Sensible efficiency in relation to the Lower Heating Value: It is the burner efficiency calculated as the ratio between conventional heating power and the burner heating power. Among the combustion losses, only the sensible heat lost with flue gasses is taken into account, thus neglecting the radiation losses and incomplete combustion losses. This value is referred to the Lower Heating Value (LHV) of the fuel and cannot exceed 100%. The sensible efficiency value is to be compared against minimum efficiency stated for the heating system performances.
η_s (HHV)	Sensible efficiency in relation to the Higher Heating Value: It is the burner efficiency calculated as the ratio between conventional heating power and the burner heating power. Among the combustion losses, only the sensible heat lost with flue gasses is taken into account, thus neglecting the radiation losses and incomplete combustion losses. This value is referred to the Higher Heating Value (HHV) of the fuel and cannot exceed 100%. The sensible efficiency value is to be compared against minimum efficiency stated for the heating system performances.
η_c (LHV)	Condensation efficiency in relation to the Lower Heating Value: Efficiency deriving from the condensation of water vapour contained in flue gases, and it is referred to the LHV.
η_c (HHV)	Condensation efficiency in relation to the Higher Heating Value: Efficiency deriving from the condensation of water vapor contained in flue gases and it is referred to the HHV.
η_t (LHV) $\eta_t = \eta_s + \eta_c$	Total efficiency in relation to the Lower Heating Value: Total efficiency. It is the sum of sensible efficiency and condensation efficiency. It is referred to LHV (Lower Heating Value) and can exceed 100%.

MEASURE	DEFINITION
η_t (HHV)	Total efficiency in relation to the Higher Heating Value: Total efficiency. It is the sum of sensible efficiency and condensation efficiency. It is referred to HHV (Higher Heating Value) and can not exceed 100%.
Q_t (HHV)	Total stack losses: It is the total heat percentage dissipated through the stack.
NOx	Measure of nitrogen oxides quantity; the measurement unit can be set in the special menu.
NOx ppm *	Measure of nitrogen oxides quantity; the measurement unit can not be set but it is fixed in ppm.
NOx (rif. O2)	Measure of nitrogen oxides quantity referring to O2; the measurement unit can be set in the special menu.
NOx (rif. O2) ppm *	Measure of nitrogen oxides quantity referring to O2; the measurement unit can not be set but it is fixed in ppm.
PI	Poison Index (CO/CO2 ratio): It is defined as the ratio between CO and CO2 useful to determine whether the system needs maintenance.
CO	CO quantity measurement. Measurement units: ppm - mg/m ³ - mg/kWh - g/GJ - g/m ³ - mg/kWh - % - ng/J
CO (RIF)	CO quantity measurement with O2 reference. Measurement units: ppm - mg/m ³ - mg/kWh - g/GJ - g/m ³ - g/kWh - % - ng/J
CO amb. ext.	Measure of the outer CO level when using the external CO probe. Measurement unit: ppm. This is the only measurement unit which is possible to set.
T dew	Flue water condensation temperature (Dew point). This value is calculated.

* : Valid for Piemonte region only (Italy only).



OTHER THAN THE MEASUREMENT LIST ABOVE, IT IS POSSIBLE TO VISUALIZE THE MEASURE OF THE DETECTED GAS ALSO IN PPM, DEPENDING ON THE KIND OF MEASUREMENT CELL IN THE INSTRUMENT. IF IT IS NECESSARY TO MEASURE THE VALUE OF GAS WITH TWO DIFFERENT MEASUREMENT UNITS, SELECT IN THE MEASUREMENTS LIST THE DESIRED GAS IN PPM AND CHANGE THE MEASUREMENT UNIT FOR THE SAME GAS IN THE "CONFIGURATION->ANALYSIS->MEASUREMENT UNIT" SCREEN. NOW THE INSTRUMENT ACQUIRES THE MEASURE WITH TWO DIFFERENT UNITS (PPM AND THE ONE PREVIOUSLY SET)

WARRANTY CERTIFICATE

WARRANTY

The S6000 flue gas analyzer is guaranteed for **24 months** from purchasing date including the internal electro-chemical sensors which are also guaranteed for **24 months** from purchasing date. Seitron undertakes to repair or replace, free of charge, those parts that, in its opinion, are found to be faulty during the warranty period. The products which are found defective during the above mentioned periods of time have to be delivered to Seitron Laboratories carriage paid. The following cases are not covered by this warranty: accidental breakage due to transport, inappropriate use or use that does not comply with the indications in the product's instruction leaflet. Any mistreatment, repairs and modifications to the product not explicitly authorized by Seitron shall invalidate the present warranty.

IMPORTANT

For the product to be repaired under Warranty, please send a copy of this Certificate along with the instrument to be repaired, together with a brief explanation of the fault observed.

Space reserved for user

Name: _____

Company: _____

User's notes:

Date: _____

S.N.: _____



4622 E. Street Rd, Trevose PA 19053 - USA - Tel. (215) 660-9777 - Email: service@seitronamericas.com

Seitron Americas Inc.

4622 Street Rd. Trevose, PA 19053 - USA

Tel: (215) 660-9777 Fax: (215) 660-9770

service@seitronamericas.com - www.seitronamericas.com