

PN-SR780M

Flat Panel Floor Cart

FOR SHARP® AQUOS BOARD®



The PN-SR780M Flat Panel Floor Cart offers the most complete mobile solution for today's interactive display system. Designed for Sharp® displays, durable 4" swivel casters provide easy maneuverability over various flooring surfaces and through doorways. Two locking casters ensure complete stability wherever the cart is placed. In addition, the continuous tilt and height adjustment assures the display will be positioned at the ideal viewing angle for the viewing audience.



Display size
60"-80"



Max load
180lb (82kg)

The PN-SR780M's wide wheel base increases the amount of work space in front of the AQUOS BOARD®.

Additional Features

- ✓ For Sharp® AQUOS BOARD® models: PN-C603D, PN-L603B, PN-L603W, PN-C703B, PN-L703B, PN-L703W, PN-L803C
- ✓ Integrated cable management protects, contains and conceals cables for a clean, professional installation
- ✓ Maneuvers easily on four 4.00" (102mm) swivel casters, two locking
- ✓ Comes standard with a six plug surge protector that provides convenient cable management on the back of the cart
- ✓ Display can be located anywhere along the column for perfect viewing height (up to 60" at center)
- ✓ Wide wheel base provides convenient access to the AQUOS BOARD®



AVAILABLE EXCLUSIVELY THROUGH YOUR SHARP® PRO-AV DEALER OR DISTRIBUTOR.

SHARP®

www.sharppusa.com/aquosboard
1-800-BE-SHARP



Cart with optional PN-SR763ACC1 Accessory Shelf

PN-SR780M	Flat Panel Floor Cart for Sharp® AQUOS BOARD®
-----------	---

Product Specifications

	DIMENSIONS (W x H x D)	PRODUCT WEIGHT	LOAD CAPACITY	FINISH	AVAILABLE COLORS
PN-SR780M	64.53" x 68.54" x 29.33" (1639 x 1741 x 745mm)	98lb (45kg)	180lb (82kg)	Powder Coat	Black

Package Specifications

	PACKAGE SIZE (W x H x D)	PACKAGE SHIP WEIGHT	PACKAGE UPC CODE	PACKAGE CONTENTS	UNITS IN PACKAGE
PN-SR780M	47.75" x 38.50" x 10.875" (1212 x 978 x 276mm)	114lb (51.6kg)	735029307235	Cart, surge protector and mounting hardware	1

Accessories

PN-SR763ACC1: PC/Keyboard Accessory Shelf

All dimensions = inch (mm)

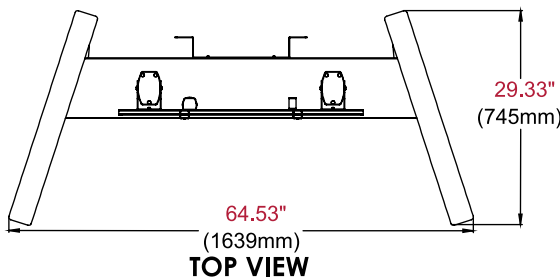

Touchboards
 205 Westwood Ave, Long Branch, NJ 07740
 Phone: 866-94 BOARDS (26273) / (732)-222-1511
 Fax: (732)-222-7088 | E-mail: sales@touchboards.com

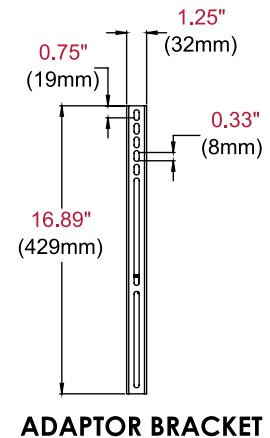
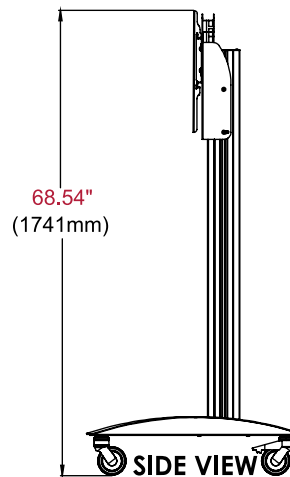
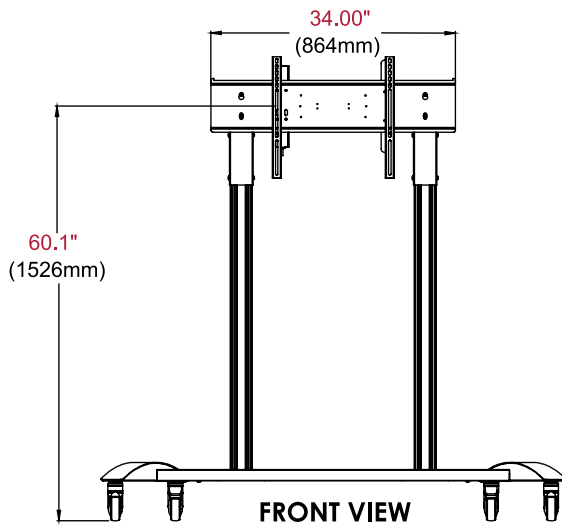

Architect Specifications

The Flat Panel Floor Cart shall be a Sharp model PN-SR780M and shall be located where indicated on the plans. Assembly and installation shall be done according to instructions provided by the manufacturer.