

FGV/E-HX DART 2.0 High Capacity Digital Force Gauges

High Capacity Digital Force Gauges with 180° reversible display & dual labeled keypad for both push, pull applications

The Series FGV-HX & FGE-HX Digital Force Gauges offer an enhanced heavy-duty housing allowing them to be utilized in high capacity tension and compression applications. These instruments are utilized in a variety of applications such as, incoming quality inspection, finished goods testing, R&D or almost any portable or force stand testing requirement.

Models are available in 200, 500 or 1000 lb ranges providing necessary performance for high capacity testing. The 180° reversible display combined with the adjustable force direction and dual labeled keypad enable these units to excel in both compression and tension applications in any direction.

The FGV-HX's add the free Toriemon software allowing further data analysis on a PC. In addition, the RS-232C and analog outputs provide maximum communication flexibility.



Features

- 1000 Hz Sample Rate provides faster sampling producing better resolution and more accurate results
- Ideal for strict tolerances with its high accuracy $\pm 0.2\%$ F.S.
- Measure and record compression and tension tests. Permits true "push-pull" testing
- 180° Reversible display and dual printed keypad allows usage as a portable gauge or mounted upside down on a test stand
- 1 million operation load cell with superior overload protection provides a long-life, damage free product
- High-capacity rugged, ergonomic die cast aluminum construction allows usage on production floor
- Variable display response rate aids viewing readings
- Quick retrieval of peak measurement with a single push button in test stand
- Flexible user preference with one button selection of engineering units
- Field calibration through keypad eliminates down time
- Dual power capable with rechargeable battery or AC line voltage
- CE Mark

FGV Models Additionally Include:

- Maximum data collection flexibility with 2 outputs: RS-232 & Analog Output



FGV-HXY with Accessories
in Protective Carrying Case

A Nidec Group Company

SHIMPO All for dreams

FGE-HX & FGV-HX Specifications

Capacity	-200HX: 200 lb, 100 kg, 1000 N; -500HX: 500 lb, 250 kg, 2500 N; -1000HX: 1000 lb, 453.6 kg, 4448 N
Resolution	0.1 lb/0.1 kg/1 N
Accuracy	±0.2% F.S.
Display	Four digit LCD, .47" high (12 mm) with various indicators including tension and low battery indication (reversible) Minus sign for tension
Average/Peak Mode	Selectable
Display Update	0.05, 0.1, 0.2, 0.3, 0.5, 1 sec
Sampling Rate	1000 Hz
Overload Capacity	150% of F.S.
Power	Rechargeable Ni-Cad batteries (included) or AC adapter/charger (included)
Auto Power Shut-Off	Yes (not active if adapter/charge is in use)
Battery Charge	12 hours (when fully charged)
Temperature Range	32 - 104°F (0 - 40°C)
Dimensions	8.43" x 3.23" x 2.15" (214 x 82 x 54.5 mm)
Product Weight	Approx. 2 lb (900 kg) for 500 lb range; 2.65 lb (1.20 kg) for 1000 lb range
Package Weight	Approx. 7.45 lb (3.38 kg) for 500 lb range; 8.25 lb (3.74 kg) for 1000 lb range
Certification	CE
Warranty	2-Year
Included Accessories	AC adapter/charger, carrying case, 2 handles, metric thread to inch adapter and attachments (flat head, hook, chisel, notched head, cone head, extension rod), RS-232 cable. RS-232 cable is included with FGV-HX series only. Note: software available at www.shimpoint.com for free download

Ordering Details

FGE-200HX	200 lb high capacity digital force gauge
FGE-500HX	500 lb high capacity digital force gauge
FGV-500HX	500 lb high capacity digital force gauge with data output
FGV-1000HX	1000 lb high capacity digital force gauge with data output
NIST-FG-HC	NIST traceable calibration certificate

Accessories

FG-M10ADP	Standard adapter set with M10 threads for ranges Includes: chisel, cone, flat head, notched head, hook, extension rod
FG-M10CL	Chisel adapter with M10 thread for ranges
FG-M10CN	Cone head adapter with M10 thread for ranges
FG-M10FL	Flat head adapter with M10 thread for ranges
FG-M10GV	Notched head adapter with M10 thread for ranges
FG-M10HK	Hook adapter with M10 thread for ranges
FG-M10RD	Extension rod adapter with M10 thread for ranges
FG-09V120UC	Universal charger adapter for 120/240V AC

Note: Additional accessory adapters available. Please contact the factory.

DISTRIBUTED BY:

FGE-HX & FGV-HX Dimensions

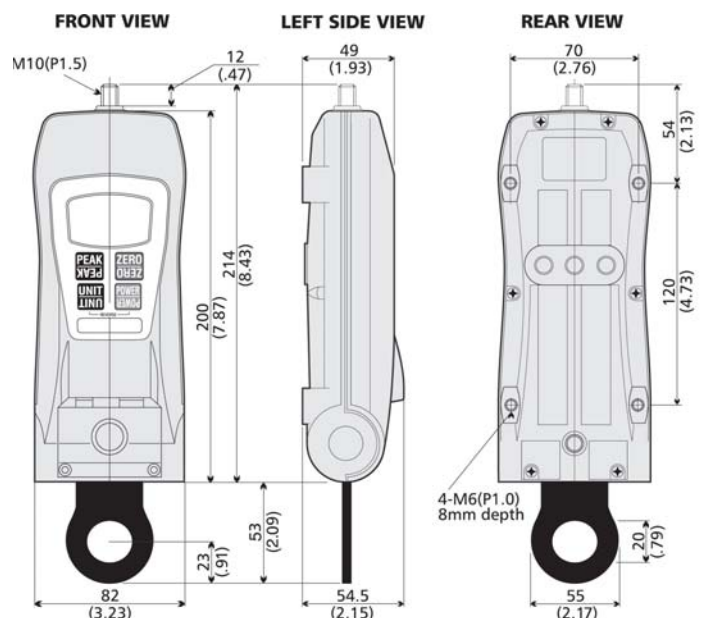

BOTTOM VIEW

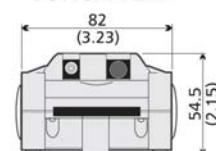

mm (inches)

A Nidec Group Company

SHIMPO All for dreams