



An ITW Company

IONIZATION SOLUTIONS



Ionizing Air Blower

Aerostat[®] PC with Heater

User's Manual

About Simco-Ion

Simco-Ion develops, manufactures and markets system solutions to manage electrostatic charge. As the world's largest provider of electrostatics management products and services, Simco-Ion improves its customers' business results by providing a total solution to their electrostatic discharge challenges. Simco-Ion Technology Group is a division of Illinois Tool Works (ITW), located in Alameda, California. For more information about Simco-Ion, visit www.simco-ion.com or call +1 800-367-2452. Simco-Ion is ISO 9001-2015 Certified.

Ion Systems' logo  is a registered trademark of
Simco-Ion, An ITW Company.
© 2020 Ion Systems. Printed in the USA.

© 2020 Simco-Ion

Important Safety Information



Carefully read the following safety information before installing or operating the equipment. Failure to follow these safety warnings could result in damage to your ionization system and/or voiding the product warranty.

- The use of improper input voltage may result in poor performance or damage to the ionizer. This will also void the warranty.
- This product is supplied with a 3-prong grounding plug, which must be inserted in an appropriate, properly wired and grounded receptacle. Do not defeat the electrical ground. For safety, the use of extension cords is not recommended.
- Do not use this Blower in an explosive environment. Poorly maintained Ionizers could produce minuscule electric arcs along the emitter. This may cause detonation in an explosive environment. Read Section 2.3 Electrical before applying power to the unit.
- To avoid personal injury or damage to the equipment, do not perform any maintenance other than that contained in these instructions. Do not insert anything within the intake or outlet grills.
- There are no user-replaceable parts inside this blower other than the emitter cartridge. Any unauthorized service will void the warranty and may result in additional repair charges. Contact your local Simco-Ion representative if the blower requires service or repair.
- For in-door use only in a non-condensing environment.
- Before performing any recommended maintenance, be sure the unit is powered off and unplugged.
- Do not point the blower face any lower than 80° from horizontal.

Informations de Sécurité Importantes



Lisez attentivement les consignes de sécurité suivantes avant d'installer ou d'utiliser l'équipement. Le non-respect de ces avertissements peut entraîner des dommages à votre système d'ionisation et/ou d'annuler la garantie du produit.

- ✓ L'utilisation d'une mauvaise tension d'entrée peut entraîner de mauvais résultats ou de détérioration de l'ioniseur. Ce sera également annuler la garantie.
- ✓ Ce produit est fourni avec un 3-broches fiche de mise à la terre, qui doit être insérée dans un accès approprié et correctement câblé et mis à la terre prise. Ne pas défaire la mise à la terre électrique. Pour des raisons de sécurité, l'utilisation de cordons d'extension n'est pas recommandée.
- ✓ Ne pas utiliser ce ventilateur dans un environnement explosif. Mal entretenu ioniseurs pourrait produire infime arcs électriques le long de l'émetteur. Cela peut provoquer de la détonation dans un environnement explosif. Lisez la Section 2.3 Installation électrique avant d'appliquer la tension de l'unité..
- ✓ Pour éviter tout risque de blessure ou de détérioration du matériel, n'effectuez aucune opération d'entretien autres que celles contenues dans ces instructions. N'introduisez rien dans le collecteur d'admission ou de sortie des barbecues.
- ✓ Il n'y a aucune pièces remplaçables par l'utilisateur l'intérieur cette soufflerie autres que l'émetteur cartouche. Tout service non autorisé annulera la garantie et peut entraîner des charges de réparation. Contactez votre représentant Simco-Ion si le surpresseur requiert un entretien ou réparation.
- ✓ Pour une utilisation sur porte uniquement dans une non-condensation environnement.
- ✓ Avant d'effectuer tout entretien recommandé, assurez-vous que l'appareil est hors tension et débranchée.
- ✓ Ne pointez pas le visage de soufflante inférieure à 80° de l'horizontale.

Contents

1 Description	1
1.1 Aerostat PC Ionizing Air Blower	2
2 Installation	4
2.1 Unpacking	5
2.2 Location	6
2.3 Electrical	7
3 Operation	8
3.1 Controls & Indicators.....	9
4 Maintenance	11
4.1 Cleaning & Adjustments.....	12
4.2 Emitter Cleaning	13
4.3 Air Inlet & Outlet Cleaning.....	14
4.4 Air Filter Cleaning	14
4.5 Ion Output Check	15
4.6 Ion Balance Check.....	16
4.7 Calibration.....	17
5 Specifications	18
6 Warranty & Service	22

1

Description

1.1 Aerostat PC Ionizing Air Blower

1.1 Aerostat PC Ionizing Air Blower

Small and quiet running, yet uncompromising in performance, Simco-Ion's Aerostat PC provides superior electrostatic discharge times rates over a targeted work surface area. It provides optimum protection from the destructive effects of ESD by neutralizing potentially destructive surface charges in the work environment.

The Aerostat PC ionized air blower produces an airflow that is rich in positive and negative ions. Directing the airflow on an object that has an electrostatic charge will neutralize the charge. If the object has a negative charge, it will draw positive ions from the airflow. Conversely, if the object has a positive charge, it will draw negative ions from the airflow. The air ions are attracted to the oppositely charged object and neutralize the charge on the object.



Figure 1. Aerostat PC Ionizing Air Blower

The Aerostat PC is a portable ionized air blower. It uses a small fan to produce airflow. The volume of airflow is controlled by a variable speed control which provides a wide range of airflow settings. The

low wattage heating element (where applicable) can be turned on at any time for user comfort. The ionizing elements are energized with a low current, high voltage transformer. The transformer contains a current limiting resistor which enhances ionization stability and provides for safety. The high voltage AC is applied to a circular arrangement of ion emitter points, which results in an intense alternating electric field at the tip of the emitter points. It is this electric field that creates alternating polarity ions in the airflow. To assure that the unit is working properly, the high voltage AC is monitored by an ionization indicator lamp.

The Aerostat PC features a balancing circuit and built-in emitter point cleaner. Using the point cleaner takes only seconds. Cleaning the emitter points prevents the build-up of airborne debris. This keeps your Aerostat PC working in top form for the life of the unit. The Aerostat PC was designed for use with sensitive electronic components, where electrostatic charge is a problem. The Aerostat PC can also be used where static electricity causes problems such as: attraction of dirt to product, misalignment of small parts due to electrostatic "jumping" and undesirable adhesion of plastic films due to electrostatic charge.

Features

- Small and portable
- Rapidly neutralizes static charges
- Covers an extended distance with ionized air
- Variable speed fan with wide range of air flow
- Low wattage heater for operator comfort (where applicable)
- Inherently balanced ion output
- Built-in ion emitter cleaner
- Ionization indicator lamp
- Durable, electrically grounded metal enclosure

2

Installation

2.1 Unpacking

2.2 Location

2.3 Electrical

2.1 Unpacking

Carefully remove the equipment from the carton and inspect all contents. Empty the carton to insure that small parts are not discarded. If any damage has occurred during the shipment, notify the local carrier immediately. A report should also be forwarded to Simco-Ion Technology Group, saleservices@simco-ion.com. See Warranty for Return Shipment information.

2.2 Location

The Aerostat PC is designed for portable or permanent operations. The bench stand can be used in a permanent location by bolting it to a sturdy flat surface such as a wall or under a shelf. If the bench stand is bolted in place, use ¼ inch diameter screws or bolts to secure it.

For extremely dirty environments, an optional air filter may be installed. The air filter consists of a filter retainer (part number 4710017) and an air filter element (part number 4100810, pack of 6).

The Aerostat PC should be placed approximately 1 to 3 feet from the critical work area or objects to be neutralized. It should be positioned to cover as much of the area as possible with the ionized air stream. The air stream can be directed upward or downward by tilting the unit in its stand. Tightening the lock knobs on each side of the unit secures it in position.

2.3 Electrical

Depending on the ordering part number, the Aerostat PC requires the following electrical power for proper operation.

Part Number	Voltage	Power Cord
4003367	120 VAC, 60 Hz	North America
4003368	230 VAC, 50 Hz	EUR (Schucko)
4008087	230 VAC, 50 Hz	UK
4015566	230 VAC, 50 Hz	China

The unit must be grounded for safe operation. Plug the supplied power cord into a standard 3-terminal grounded receptacle. If an extension cord is necessary, use only a 3-wire extension cord that provides grounding.

3

Operation

3.1 Controls & Indicators

3.1 Controls & Indicators

Activate the Aerostat PC by turning the FAN SPEED knob clockwise, out of the OFF position. The IONIZATION INDICATOR will illuminate to indicate the presence of ionized air. Set the airflow as desired by adjusting the FAN SPEED knob. If warm air is available / desired for operator comfort, set the WARM AIR switch to the ON (1) position. The direction of the air stream can be adjusted upward or downward by loosening the LOCK KNOBS, tilting the unit and retightening the knobs. To clean the ion emitter points, rotate the POINT CLEANER knob clockwise to the stop (approximately one turn) and release.



Figure 2. Aerostat PC Identification

- 1. Emitter Point Cleaner Knob
- 2. Ionization Indicator
- 3. Warm Air Switch
- 4. Tilt Position Lock Knob
- 5. Fan Speed Control Knob

The Aerostat PC produces an ionized air stream that covers a targeted area. The time required to neutralize a static charge on an item in the air stream depends on many factors. Two important factors are; distance to ionizer and air velocity. Air ions constantly "neutralize" each other. Positive and negative ions are electrostatically attracted to each other. When they contact, the charge transfers and the ions "recombine". With high air velocity, the air ions travel further before they "recombine". Setting the fan speed as high as acceptable results in more rapid neutralization. For fast neutralizing, the item should be held within 1 to 3 feet from the Aerostat. For virtually instantaneous neutralization, the item may be held as close as 6 inches.

When using the Aerostat in an electronics assembly area, the ionized air stream should cover as much of the work area as possible. Charged items introduced into the work area will be neutralized and will remain neutral while in the ionized air stream.

4

Maintenance

- 4.1 Cleaning & Adjustments
- 4.2 Emitter Cleaning
- 4.3 Air Inlet & Outlet Cleaning
- 4.4 Air Filter Cleaning
- 4.5 Ion Output Check
- 4.6 Ion Balance Check
- 4.7 Calibration

4.1 Cleaning & Adjustments

The Aerostat PC has been designed with low maintenance in mind. The only regular maintenance suggested is emitter point cleaning, ion balance checking and ion output checking. Emitter point cleaning takes only seconds with the point cleaner. The Aerostat PC contains a balancing circuit that is inherently self-balancing. This circuit compensates for dirt build-up on emitters, emitter point wear, line voltage fluctuations and variations in air velocity. Scheduled checking of the ion output and balance should be considered to assure quality audit requirements.

4.2 Emitter Cleaning

To clean the ion emitter points: simply rotate the point cleaner knob located at the center of the outlet grille clockwise to the stop (approximately one turn) and release. The spring-loaded point cleaning brush will return to its parking spot. Recommended frequency of emitter point cleaning is every 160 hours of operation. (Weekly for 24 hr/day operation, monthly for 8 hr/day operation.)

4.3 Air Inlet & Outlet Cleaning

The air inlet grille on the rear of the unit and the ionized air outlet should remain clean to prevent restriction of air flow. They can be cleaned with a soft brush or vacuum.

4.4 Air Filter Cleaning

Check the air filter regularly for dirt. If the Aerostat PC is used on a regular basis.

Remove the air filter from the rear of the unit by unsnapping the filter retainer. Rinse the filter in plain water while gently squeezing. If the dirt is stubborn, wash the filter in mild soap and water then rinse. Blot the filter dry with paper towels and allow to dry. Install filter on air inlet and secure by snapping the filter retainer in place.

4.5 Ion Output Check

To test the unit for ion output, the use of a charged plate monitor is recommended. Discharge times can be measured and checked against the Discharge Specification values in Section 5. If a charged plate monitor is not available, but a static meter such as a Simcolon handheld electrostatic field meter is available, ion output may be checked with the following procedure. Take a piece of plastic and rub it with cloth until a static charge can be read with the static meter. Turn on the Aerostat PC. Hold the plastic one foot away from the ionized air outlet for five seconds. Remove the plastic from the ionized air stream and measure the static charge. The plastic should be neutralized.



Do not insert objects through the unit's intake or outlet grilles while in operation. Damage to the ionizer and/or personal injury may result.

Do not try to verify operation of the unit by drawing a spark from an ion emitter point. The design of the balancing circuit makes the "spark test" inconclusive. Sustained grounding of the ion emitters may damage the balancing circuit.



N'insérez pas d'objets dans l'unité de grilles d'entrée ou de sortie en cours de fonctionnement. Dommages pour l'ioniseur et/ou peut entraîner des blessures graves.

Ne pas essayer de vérifier le fonctionnement de l'unité en dessinant une étincelle provenant d'un émetteur d'ions point. La conception du circuit d'équilibrage rend le "contrôle d'allumage" non concluantes. Mise à la terre soutenue des émetteurs d'ions peut endommager le circuit d'équilibrage.

4.6 Ion Balance Check

To test the unit for ion balance, the use of a charge plate monitor is recommended. Offset voltage should be measured and checked against the Ion Balance in Specification Section 5. Do not try to determine ion balance by holding a static meter in the ionized air stream. This will result in a meaningless reading.

4.7 Calibration

The Aerostat PC's ion output is inherently balanced by design. As a result, there are no calibration adjustments. If, after checking the ion balance as outlined above, an unbalance or offset voltage exists in excess of +/-10 volts, contact Simco-Ion Technical Support at techsupport@simco-ion.com.





5

Specifications

5.1 Specifications

5.2 Parts & Accessories

5.1 Specifications

Input Voltage	120 VAC, 60 Hz, 1.7A*; 230 VAC, 50 Hz, 0.9A				
Discharge (in sec)		<u>1 ft</u>	<u>2 ft</u>	<u>3 ft</u>	<u>4 ft</u>
Fan Low	6" off center	10	14	24	34
	center	4	9	16	24
Fan High	6" off center	5	7	11	34
	center	2	5	6	10
Balance	±10V @ 1'				
Air Volume	Low fan 35 cfm; high fan 70 cfm				
Air Velocity	<u>1 ft</u>	<u>2 ft</u>	<u>3 ft</u>	<u>4 ft</u>	
Low	250 fpm	200 fpm	150 fpm	125 fpm	
High	500 fpm	400 fpm	300 fpm	250 fpm	
	(measured at center line of air stream)				
Audible Noise	Fan low 50 dB; fan high 57 dB (measured @ 2 ft from unit)				
Coverage	1' x 5'				
Heated Air Temp	Fan High: 12-15°F (7-8°C) above ambient; Fan Low: 6-8°F (4-5°C) above ambient, measured at 12" in front of blower (Heater optional)				
Operating Env.	Temperature 15-35°C (59-95°F) recommended; relative humidity 20-65%				
Ozone	0.01 ppm (measured @ 6" in front of unit, fan low)				
Air Filter	30 PPI Open cell Polyurethane foam				
Enclosure	Aluminum; paint, polyester/Epoxy				
Weight	5.7 lbs (2.6 kg) with heater				
Dimensions	5 ½W x 8 5/8H x 3 ¼D in. (14 x 22 x 8.4 cm)				
Warranty	Two year limited warranty				
Certifications	   				

Offset voltage and discharge time determined as per ANSI/ESD STM3.1-2006 using a 6" x 6", 20 pF plate (charged plate monitor). Discharge times are in seconds from 1000 volts to 100 volts at locations shown.

Note: Discharge times for high speed are 10% longer for 230 V, 50 Hz.

5.2 Parts & Accessories

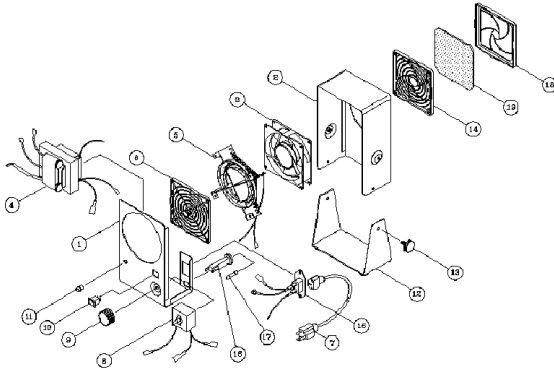

Item No.	Part No.	Description
1	4251616	Chassis
2	4251617	Cover
3	4104522	Fan, 120 VAC
3	4104539	Fan, 230 VAC
4	4108534	HV Transformer with Leads, 120 VAC
4	4108535	HV Transformer with Leads, 230 VAC
5	4104523	Ionizer / Heater Assembly, 120 VAC
5	4104540	Ionizer / Heater Assembly, 230 VAC
6	4104515	Outlet Grille (includes point cleaner)
7	5050767	Line Cord, 120 VAC (North American)
7	5050768	Line Cord, 230 VAC (Continental European)
7	5051191	Line Cord, 230 VAC (UK / Ireland)
7	5051726	Line Cord, 230 VAC (China)
8	4104526	Fan Speed Control, 120 VAC
8	4104542	Fan Speed Control, 230 VAC
9	4104514	Knob (for speed control)
11	4610782	Indicator Lamp Lens
12	4104524	Bench Stand
13	4670900	Lock Knob (2 required)
14	4710018	Air Inlet Grille
15	4108453	Cord Inlet Assembly (120 VAC Units)

15	4108454	Cord Inlet Assembly (230 VAC Units)
16	4612205	Fuse Holder
17	28-21459	Fuse, 5 x 20 mm, 5.0 A, Slo-Blo (units with heater)
18	4710017	Air Filter Retainer (optional accessory)
19	4100810	Air Filter Element, Package of 6 (optional accessory)

6

Warranty & Service

Simco-Ion provides a limited warranty for the Aerostat PC Ionizing Blower. New products manufactured or sold by Simco-Ion are guaranteed to be free from defects in material or workmanship for a period of two (2) years from date of initial shipment. Simco-Ion liability under its new product warranty is limited to servicing (evaluating, repairing, or replacing) any unit returned to Simco-Ion that has not been subjected to misuse, neglect, lack of routine maintenance, repair, alteration, or accident. In no event shall Simco-Ion be liable for collateral or consequential damages. Consumable items such as, but not exclusive to, emitter points, emitter wires, batteries, filters, fuses or light bulbs are only covered under this warranty if found defective as received with the new product.

To obtain service under this warranty, please contact Simco-Ion Technical Support at techsupport@simco-ion.com or +1 (510) 217-0470.



SIMCO ION™

An ITW Company

Technology Group

1141 Harbor Bay Pkwy, Ste 201

Alameda, CA USA 94502

Toll free: +1 800-367-2452

Sales services: +1 510-217-0460

Tech support: +1 510-217-0470

Fax: +1 510-217-0484

saleservices@simco-ion.com

techsupport@simco-ion.com

www.simco-ion.com