







## AEROSTAT<sup>®</sup> XC

### EXTENDED COVERAGE IONIZING BLOWER

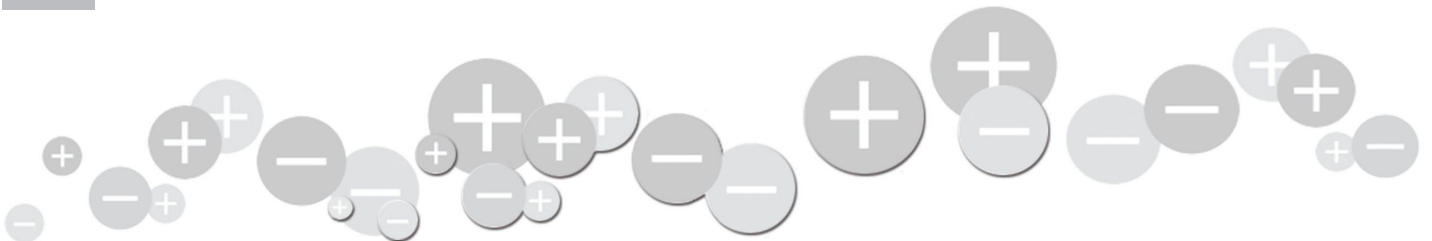
Simco-Ion's AeroStat XC Extended Coverage Ionizing Blower provides excellent coverage, balance stability, and rapid static charge decay times. The XC can be used in a variety of applications, such as injection molding, device manufacturing and packaging. The XC features Simco-Ion's emitter point cleaner, an ionization status light and an integrated heater. The XC neutralizes static across a broad three-foot by six-foot area and operates on AC technology to provide stabled balanced performance over time.

- Improves productivity by rapidly neutralizing sheets and other surfaces
- Neutralizes charges over the entire workbench
- Easy to maintain sustainable static charge control
- Easy to verify the presence of ionization
- Provides a comfortable working environment for operators, ensuring continuous operation
- Optional air filter to adapt for use in extremely dusty environments



Specifications																				
<b>Input Voltage</b>	120 VAC, 60 Hz: 0.6A (high fan/heater off); 3.6A (high fan/heater on) 220-230 VAC, 50 Hz: 0.3A (high fan/heater off); 1.8 (high fan/heater on)																			
<b>Discharge</b>	1.5 sec @ 1' (30 cm); fan speed high (1000-100V) <sup>1</sup>																			
<b>Balance</b>	0 ±10V																			
<b>Ion Emission</b>	AC Ionization																			
<b>Emitters</b>	Stainless Steel																			
<b>Controls</b>	POWER ON/OFF switch, WARM AIR ON/OFF switch; FAN SPEED control LOW/MEDIUM/HIGH, Emitter Point Cleaner Knob																			
<b>Indicators</b>	Orange IONIZATION status; orange within POWER and WARM AIR switches																			
<b>Coverage</b>	3' x 5' to 2.5' x 6' (91 x 152 cm) to (76 x 183 cm) area																			
<b>Air Volume</b>	70 cfm (low), 95 cfm (medium), 120 cfm (high)																			
<b>Air Velocity<sup>2</sup></b>	Fan Speed: <table border="1"> <tr> <td>1'</td> <td>2'</td> <td>3'</td> <td>4'</td> </tr> <tr> <td>Low:</td> <td>600</td> <td>300</td> <td>180</td> <td>150</td> </tr> <tr> <td>Medium:</td> <td>800</td> <td>400</td> <td>220</td> <td>180</td> </tr> <tr> <td>High:</td> <td>1000</td> <td>500</td> <td>250</td> <td>200</td> </tr> </table>	1'	2'	3'	4'	Low:	600	300	180	150	Medium:	800	400	220	180	High:	1000	500	250	200
1'	2'	3'	4'																	
Low:	600	300	180	150																
Medium:	800	400	220	180																
High:	1000	500	250	200																
<b>Heated Air Temp</b> (heater optional)	Fan high: 4-5°F (2-3°C) above ambient Fan medium: 4-5°F (2-3°C) above ambient; Fan low: 5-7°F (3-4°C) above ambient (measured @ 12" in front of blower)																			
<b>Operating Env.</b>	Temperature 50-95°F (10-35°C); humidity 30-70% RH, non-condensing																			
<b>Audible Noise</b>	Fan speed: low 52 dB, medium 58 dB, high 64 dB																			
<b>Ozone</b>	0.05 ppm, measured @ 6" in front of unit <sup>3</sup>																			
<b>Air Filter</b>	30 ppi open cell polyurethane foam (optional)																			
<b>Mounting</b>	Metal stand/bracket included (optional pedestal mount kit for elevated mounting and locking stand kit)																			
<b>Enclosure</b>	Powder-coated white steel																			
<b>Dimensions</b>	15.375"W x 4.5"H x 8.125"D (39.1 x 11.4 x 20.6 cm)																			
<b>Weight</b>	17.5 lb (7.9 kg)																			
<b>Warranty</b>	Two year limited warranty																			
<b>Certifications</b>	 120V, 60 Hz  																			

1. Tested in accordance with ANSI/ESD STM3.1-2015.
2. Velocity in fpm measured at center line of air stream.
3. Test conducted in accordance with EPA EQQA-0577-019 using Dasibi Ozone Monitor Model 1003AH.

## Part Numbers

<b>I-4002612</b>	Aerostat XC, 120V
<b>I-4015593</b>	Aerostat XC, 230V
<b>I-5050282</b>	Aerostat XC Pedestal Mount Kit
<b>I-5051321</b>	Aerostat XC Air Filter Kit
<b>I-33-6010-01</b>	Locking Stand Kit
<b>I-4470059</b>	Aerostat XC Air Filter Replacement

## Wide Variety of Applications

The Aerostat XC is a mid-size anti-static blower, designed for use in controlled environments, where the goal is to eliminate static charge and electrostatic attraction on various parts and processes. The XC is widely used in the electronics manufacturing and medical device assembly, test and packaging processes. The Aerostat XC easily mounts on a workbench or integrates into an existing assembly area where space is at a premium and neutralizing capability is critical.

## Discharge Times

Discharge times are tested in accordance with ANSI/ESD STM3.1-2015. Each point shows the discharge times (1000-100V) with high fan/low fan speed.

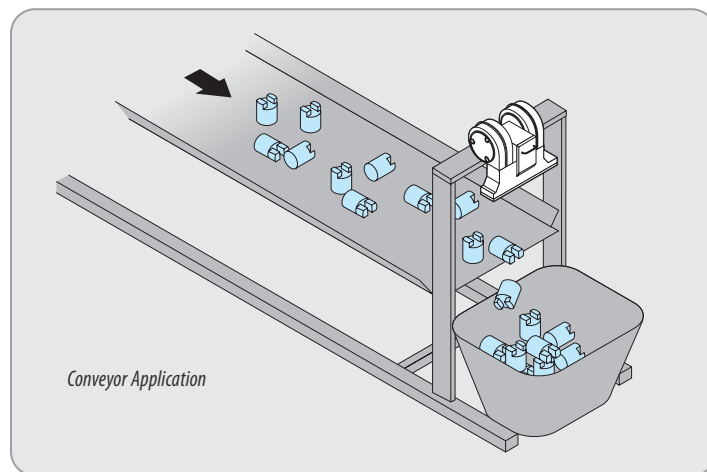
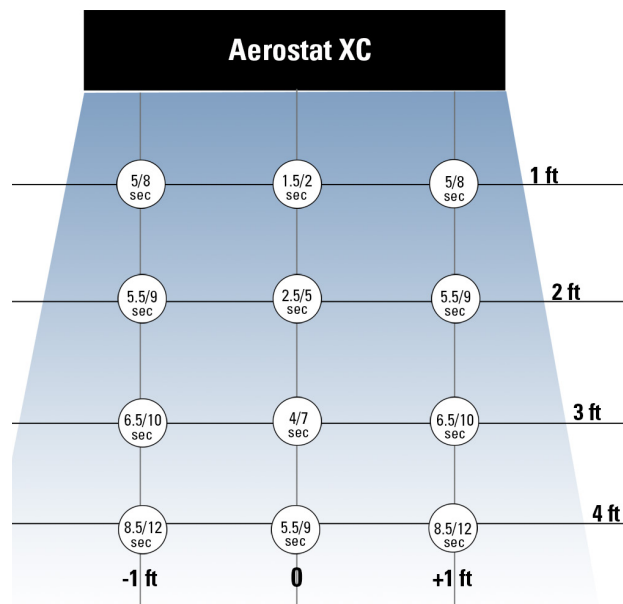

Thermoforming trays can attract dirt and contamination that results in rejects. Installing a static control blower directly above the delivery of the trays, offers improved product quality with the reduction of dust and dirt.

**SIMCO ION**™  
An ITW Company

5201320 Rev B  
© 2021 Simco-Ion  
All rights reserved.

**Simco-Ion**  
2257 North Penn Road  
Hatfield, PA 19440-1998  
Tel: 800.203.3419 (in USA)  
Tel: 215.822.6401  
customerservice@simco-ion.com  
www.simco-ion.com