



An ITW Company

IONIZATION SOLUTIONS



Ionizing Air Blower

Aerostat® XC

User's Manual

About Simco-Ion

Simco-Ion develops, manufactures, and markets system solutions to manage electrostatic charge. As the world's largest provider of electrostatics management products and services, Simco-Ion improves its customers' business results by providing a total solution to their electrostatic discharge and electromagnetic interference challenges. Simco-Ion Technology Group is a division of Illinois Tool Works (ITW), located in Alameda, California. For more information about Simco-Ion visit www.simco-ion.com (Technology Group) or call +1 800-367-2452. Simco-Ion is ISO 9001-2008 Certified.

Ion Systems' logo  is a registered trademark of Simco-Ion, An ITW Company.

© 2019 Ion Systems. Printed in the USA.

© 2019 Simco-Ion

Important Safety Information



Carefully read the following safety information before installing or operating the equipment. Failure to follow these safety warnings could result in damage to your ionization system and/or voiding the product warranty.

- This unit is supplied with a 3-prong grounding plug, which must be inserted in an appropriate, properly wired, and grounded receptacle. Do not defeat the electrical ground. Grounding and proper wiring are required for safe and efficient operation.
- Keep the unit dry. Do not operate the ionizer in flammable, or explosive atmospheres.
- Do not insert objects through the unit's intake or outlet grilles. Damage to the ionizer and/or personal injury may result.
- Do not ground or make electrical connections of any kind to the unit's metal fan guards located on the intake and output.
- A factory-qualified service technician must perform component service and repairs. Please contact Simco-Ion Customer Service for information.

Informations de Sécurité Importantes



Lisez attentivement les consignes de sécurité suivantes avant d'installer ou d'utiliser l'équipement. Le non-respect de ces avertissements peut entraîner des dommages à votre système d'ionisation et/ou d'annuler la garantie du produit.

- Cette unité est fournie avec un 3-broches fiche de mise à la terre, qui doit être insérée dans un approprié, correctement câblé et boîtier raccordé à la terre. Ne pas défaire la mise à la terre électrique. La mise à la terre et le câblage correct sont requis pour un fonctionnement sûr et efficace.
- Garder l'unité sec. Ne pas faire fonctionner le ioniseur, inflammables ou atmosphères explosives.
- N'insérez pas d'objets dans l'unité de grilles d'entrée ou de sortie. Dommages pour l'ioniseur et/ou peut entraîner des blessures graves.
- Ne porter pas à la masse ou des connexions électriques de toute nature à l'unité en métal de protections du ventilateur situé sur l'admission et la sortie.
- Usine d'un technicien qualifié doit effectuer composant service et réparations. Veuillez contacter Simco-Ion Service client pour plus d'informations.

Contents

1 Description	1
1.1 Aerostat® XC Ionizing Air Blower	2
1.2 Aerostat XC Identification	4
2 Installation	5
2.1 Unpacking	6
2.2 Location	7
2.3 Electrical	8
3 Operation	9
3.1 Controls & Indicators.....	10
4 Maintenance	12
4.1 Cleaning & Adjustments.....	13
4.2 Emitter Cleaning	14
4.3 Air Inlet & Outlet Cleaning.....	15
4.4 Optional Air Filter Cleaning.....	16
4.5 Ion Output Check	17
4.6 Ion Balance Check.....	18
4.7 Calibration.....	19
5 Specifications	20
6 Warranty & Service	25

1

Description

- 1.1 Aerostat® XC Ionizing Air Blower
- 1.2 Aerostat XC Identification

1.1 Aerostat[®] XC Ionizing Air Blower

Simco-Ion's Aerostat XC was designed for use with sensitive electronic components where electrostatic discharge (ESD) is a problem. It can be applied in inspection, testing, and assembly environments. The Aerostat XC can also be used where static electricity causes problems such as attraction of dirt to product, misalignment of small parts due to electrostatic "jumping", and undesirable adhesion of plastic films due to electrostatic charge.

The Aerostat XC ionized air blower produces an air flow that is rich in positive and negative ions. Directing the air flow on an object that has a static charge will neutralize the charge. If the object has a positive static charge, it will draw negative ions from the air flow. If the object has a negative static charge, it will draw positive ions from the air flow. The ions are attracted to the oppositely charged object and neutralize the electrostatic charge on the object.



Figure 1. Aerostat XC Ionizing Air Blower

The Aerostat XC uses a three-speed tangential blower to produce a uniform air flow. This air flow is directed into a duct, which shapes the airflow. The duct also contains a heater and ionizer. The low-wattage heater can be turned on at any time for user comfort. The ionizer uses a transformer which produces high voltage AC. The transformer output contains a current limiting resistor which provides redundant safety and enhances the ionization stability.

The high voltage AC is applied to a row of stainless steel emitter pins, which results in an intense alternating electric field at the tip of the emitters. It is this intense electric field that introduces alternating polarity ions into the air flow. The shaped air flow exiting the Aerostat XC carries these ions over a broad area for control of electrostatic charge. To ensure that the unit is working properly, the output is monitored by an ionization indicator lamp.

The ionizer of the Aerostat XC features an exclusive balancing circuit. This results in the equal production of positive and negative ions. The Aerostat XC also features a built-in emitter cleaner. Taking a few seconds to clean the emitters on a weekly basis prevents the build-up of debris on the emitter pins, keeping your AeroStat, keeping your Aerostat XC working in top form for the life of the unit.

Features

- Rapidly neutralizes static charges
- Covers an extended area with ionized air
- Three-speed fan with wide range of air flow
- Low-wattage heater for operator comfort
- Tilt Bench stand, or optional pedestal mount.
- Inherently balanced ion output
- Built-in ion emitter cleaner
- Ionization indicator lamp
- Durable, electrically grounded steel enclosure

1.2 Aerostat XC Identification

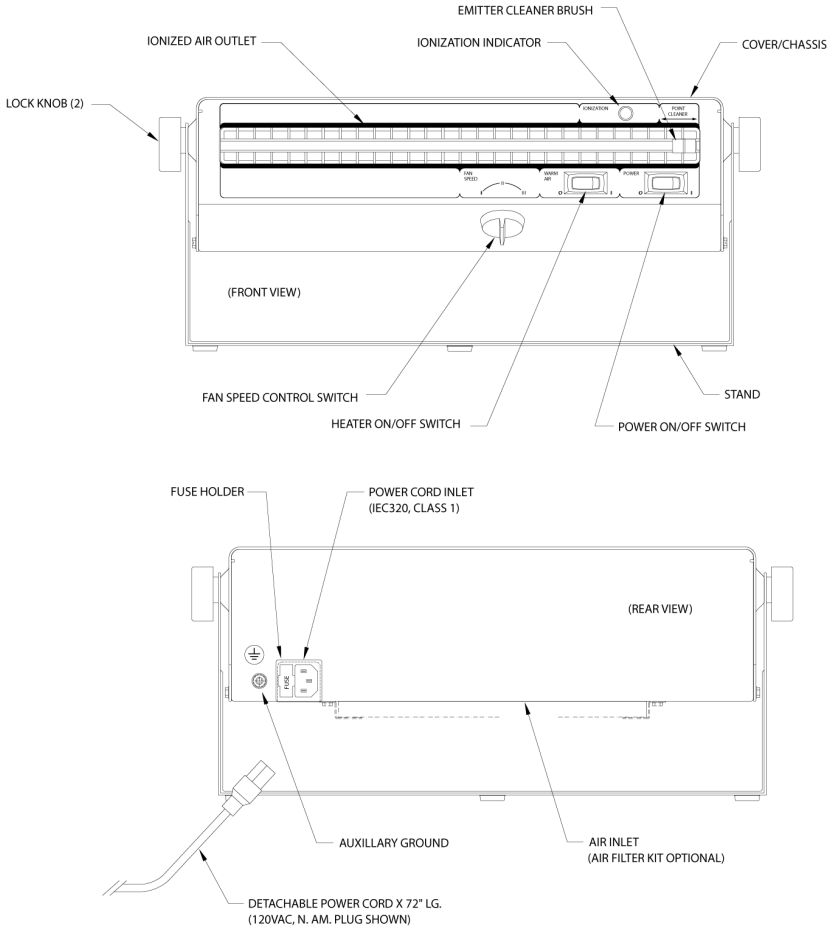

Figure 2. Aerostat XC Identification

2

Installation

2.1 Unpacking

2.2 Location

2.3 Electrical

2.1 Unpacking

Carefully remove the equipment from the carton and inspect all contents. Empty the carton to insure that small parts are not discarded. If any damage has occurred during the shipment, notify the local carrier immediately. A report should also be forwarded to Simco-Ion Technology Group email address at sallesservices@simco-ion.com. See Warranty section for Return Shipment information.

2.2 Location

The Aerostat XC is designed for free or fixed position operation on a table top or work bench surface. Each unit includes an adjustable, skid resistant stand intended for placement onto the selected surface. Holes in the base of the stand are provided for securing the unit in a fixed location using 5/16 diameter screw hardware (not provided).

An optional pedestal kit is available for elevated mounting.

For extremely dusty environments, an optional air filter kit is available. The air filter kit includes support brackets, screw hardware, and a polymer foam air filter. The air filter is cleanable and reusable. See section 5 for air filter ordering part numbers

The Aerostat XC should be placed approximately 1 to 3 feet (0.3 to 1.0 meters) from the objects to be neutralized or the critical work area. It should be positioned to cover as much of the area with the ionized air stream as possible. The air stream can be directed upward or downward by tilting the unit within the stand. Tightening the lock knobs on each side of the unit secures it in position.

2.3 Electrical

Depending on the ordering part number, the Aerostat XC requires the following electrical power for proper operation.

Part Number	Voltage	Power Cord
4002612	120 VAC/60 Hz	North America
4002667	230 VAC/50 Hz	EUR (Schuko)
4009044	230 VAC/50 Hz	UK
4015593	230 VAC/50Hz	China

The unit must be grounded for safe and efficient operation. Plug the supplied power cord into a standard 3-terminal grounded receptacle. If an extension cord is necessary, use only a three wire extension cord that provides grounding.

3

Operation

3.1 Controls & Indicators

3.1 Controls & Indicators

Activate the XC by setting the POWER switch to the ON position. The ionization indicator will illuminate to indicate the presence of ionized air. Set the air flow as desired by adjusting the FAN SPEED to low (I), medium (II), or high (III). If warm air is desired for operator comfort, set the HEATER switch to the ON (I) position. The direction of the air stream can be adjusted upward or downward by loosening the lock knobs, tilting the unit and retightening the knobs.

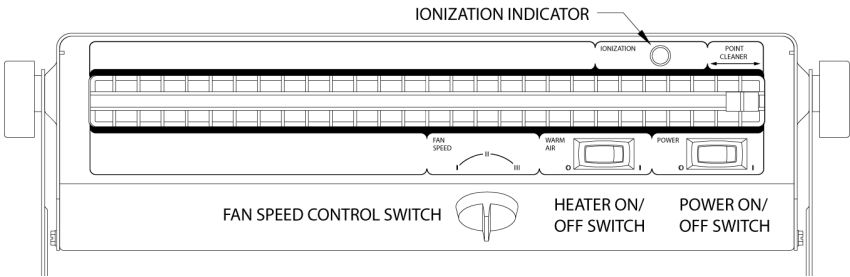

Figure 3. Aerostat XC Controls and Indicators

The Aerostat XC produces an ionized air stream that covers a large area uniformly. The time required to neutralize a static charge on an item in this area depends on many factors.

Two important factors are:

- Distance to the ionizer
- Air velocity

Air ions constantly "neutralize" each other. Positive and negative ions are attracted to each other. When they contact, the charge transfers and the ions recombine. With high air velocity, the ions travel further before they recombine. Setting the fan speed to high results in coverage for the greatest possible area. Decreasing the distance to the ionizer results in more rapid neutralization. For fast neutralizing, the item should be placed approximately 1 to 3 feet (0.3 to 1.0 meters) from the objects. For virtually instantaneous neutralizing, the item may be held as close as 6 inches.

When using the Aerostat XC in an electronics assembly area, the ionized air stream should cover as much of the work area as possible. The constant flow of ionized air will prevent items such as work surfaces, tools, materials and components from developing a static charge. Charged items introduced into the work area will be neutralized and will remain neutral while they are in the air stream.

4

Maintenance

- 4.1 Cleaning & Adjustments
- 4.2 Emitter Cleaning
- 4.3 Air Inlet & Outlet Cleaning
- 4.4 Optional Air Filter Cleaning
- 4.5 Ion Output Check
- 4.6 Ion Balance Check
- 4.7 Calibration

4.1 Cleaning & Adjustments

The Aerostat XC has been designed with low maintenance in mind. The only regular maintenance suggested is emitter point cleaning, ion balance checking and ion output checking. Emitter point cleaning takes only seconds with Simco-Ion's built-in point cleaner. The Aerostat XC contains a balancing circuit that is inherently self balancing. This circuit compensates for dirt build-up on emitters, emitter point wear, line voltage fluctuations and variations in air velocity. Scheduled checking of the ion output and balance should be considered to assure quality audit requirements.



ELECTRICAL SHOCK HAZARD!

Do not insert objects through intake or outlet grille.



RISQUE DE CHOC ÉLECTRIQUE !

N'insérez pas d'objets à l'admission ou grille de sortie.

4.2 Emitter Cleaning

To clean the ion emitters, simply sweep the emitter cleaner back and forth once across the ionized air outlet. Recommended frequency of cleaning is once a week.

4.3 Air Inlet & Outlet Cleaning

The air inlet grille on the rear of the unit and the ionized air outlet should remain clean to prevent restriction of air flow. They can be cleaned with a soft brush or vacuum.

4.4 Optional Air Filter Cleaning

Remove the air filter from the rear of the unit by sliding the aluminum frame of the filter towards the rear of the unit. Rinse the filter in plain water while gently squeezing. If the dirt is stubborn, wash the filter in mild soap and water then rinse. Blot the filter dry with paper towels and allow to dry. Reinstall filter on air inlet by sliding it under brackets from rear of the unit.



If an air filter is used, clean the air filter regularly.



Si un filtre à air est utilisé, nettoyez régulièrement le filtre à air.

4.5 Ion Output Check

To test the unit for ion output, the use of a charge plate monitor is recommended. Discharge times can be measured and checked against the Discharge Specification in Section 5.

If a charge plate monitor is not available, but a static meter such as a Simco-Ion handheld electrostatic fieldmeter is available, ion output may be checked with the following procedure. Take a piece of plastic and rub it with cloth until a static charge can be read with the static meter. Turn on the Aerostat XC. Hold the plastic one foot away from the ionized air outlet for five seconds. Remove the plastic from the ionized air stream and measure the static charge. The plastic should be neutralized.

Do not try to verify operation of the unit by drawing a spark from an ion emitter point. The design of the balancing circuit makes the "spark test" inconclusive. Sustained grounding of the ion emitters may damage the balancing circuit.

4.6 Ion Balance Check

To test the unit for ion balance, the use of a charge plate monitor is recommended. Offset voltage should be measured and checked against the Balance Specification in Section 5.

If a charge plate monitor is not available you may use a Simco-Ion brand electrostatic fieldmeter equipped with a removable test plate. Follow the instructions in the fieldmeter instruction booklet for the ion balance test procedure.

4.7 Calibration

The Aerostat XC's ion output is inherently balanced by design, so there are no calibration adjustments. If after checking the ion balance as outlined above, an unbalance or offset voltage exists in excess of 0 ± 5 volts, contact Simco-Ion Technical Support at 510-217-0470 or email techsupport@simco-ion.com.

Never open the case of the unit. This exposes hazardous voltages. If repairs are necessary, call Simco-Ion for a Return Authorization Number and return the unit to the factory.

5





Specifications

5.1 Specifications

5.2 Parts & Accessories

5.3 Dimensional Drawing

5.1 Specifications

Input Voltage	120 VAC, 60 Hz, 0.6-3.6A (heater on) 230 VAC, 50 Hz, 0.3-1.8A (heater off)				
Discharge*	<u>1 ft</u>	<u>2 ft</u>	<u>3 ft</u>	<u>4 ft</u>	
Fan High	5/1.5	5.5/2.5	6.5/4	8.5/5.5	12"/Center
Fan Medium	6/1.7	7/3.5	9/5	11/7	12"/Center
Fan Low	8/2	9/5	10/7	12/9	12"/Center
Balance	0 ±10V				
Air Volume	Fan low 70 cfm; fan medium 95 cfm; fan high 102 cfm				
Air Velocity (fpm)	<u>1 ft</u>	<u>2 ft</u>	<u>3 ft</u>	<u>4 ft</u>	
Fan Low	600	300	180	150	
Fan Medium	800	400	220	180	
Fan High	1000	500	250	200	
	(measured @ center line of air stream)				
Coverage	3' x 6'				
Heated Air Temp	Fan High: 4-5°F (2-3°C) above ambient; Fan Medium: 4-5°F (2-3°C) above ambient; Fan Low: 5-7°F (3-4°C) above ambient, measured at 12" in front of blower (Heater optional)				
Operating Env.	Temperature 50-95°F (10-35°C); humidity 30-70% RH, non-condensing				
Ozone	0.005 ppm measured @ 6" in front of unit; test conducted in accordance with EPA EQOA-0577-019 using Dasibi ozone monitor model 1003AH				
Audible Noise	Fan low 52 dB; fan medium 58 dB; fan high 64 dB (measured @ 2' from unit)				
Optional Air Filter	30 ppi open cell polyurethane foam				
Enclosure	Formed steel, white polyester paint				
Weight	17.5 lbs (7.9 kg)				
Dimensions	15-3/8W x 4-1/2H x 8-1/8D in. (39.1 x 11.4 x 20.6 cm)				
Warranty	Two year limited warranty				
Certifications			230V, 50 Hz		120V, 60 Hz 

* Tested in accordance with ANSI/ESD STM3.1-20015.

Note: Discharge times at high speed are approx. 10% longer for 230 V, 50 Hz.

5.2 Parts & Accessories

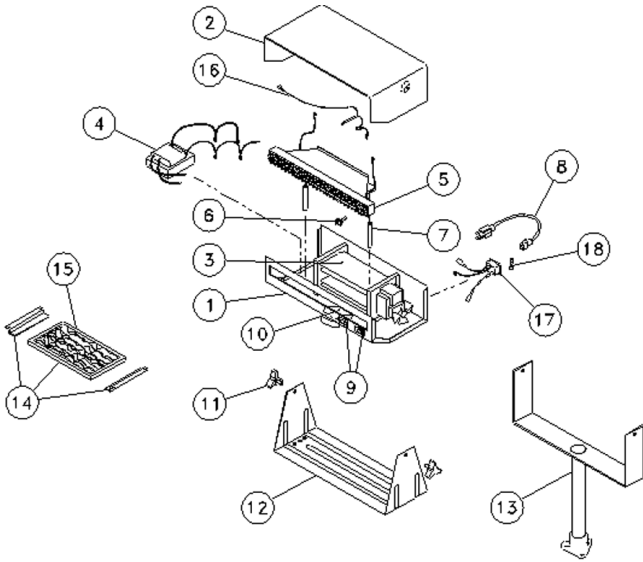

Part No.	Description
4343230	Chassis
4108398	Lid Assembly
4710066	3-Speed Blower, 120 VAC
4710077	3-Speed Blower, 230 VAC
4108537	HV Transformer with Leads, 100 VAC
4108538	HV Transformer with Leads, 120 VAC
4108540	HV Transformer with Leads, 230 VAC
4103939	Ionizer Duct Assembly, 120 VAC (with Heater)
4104036	Ionizer Duct Assembly, 230 (with Heater)
4104100	Ionizer Duct Assembly, 120/230 VAC (without Heater)
4670700	Brush
4401510	Ionizer Duct Standoff (2 required)
5050767	Line Cord, 120 VAC (N. Am.)
5050768	Line Cord, 230 VAC (Continental European)
5051191	Line Cord, 230 VAC (UK / Ireland)
5051726	Line Cord, 230 VAC (China)

4610699	Illuminated Rocker Switch, 120 VAC
4610729	Illuminated Rocker Switch, 230 VAC
4610700	3-Position Rotary Switch and Knob
4670063	Lock Knob (2 required per unit)
4103942	Stand Assembly
5050282	Pedestal Mount (includes hardware)
5051321	Air Filter Kit (includes filter, mounting brackets, hardware)
4470059	Air Filter
4104354	Ionizer indicator assembly
4108400	Inlet Assembly
28-21459	Fuse, 5x20 mm, 5.0A, Slo-Blo, (Units with Heater)
10648-002	Fuse, 5x20 mm, 2.5A, Slo-Blo, (Units without Heater)
33-6010-01	Locking stand kit (optional)

5.3 Dimensional Drawing

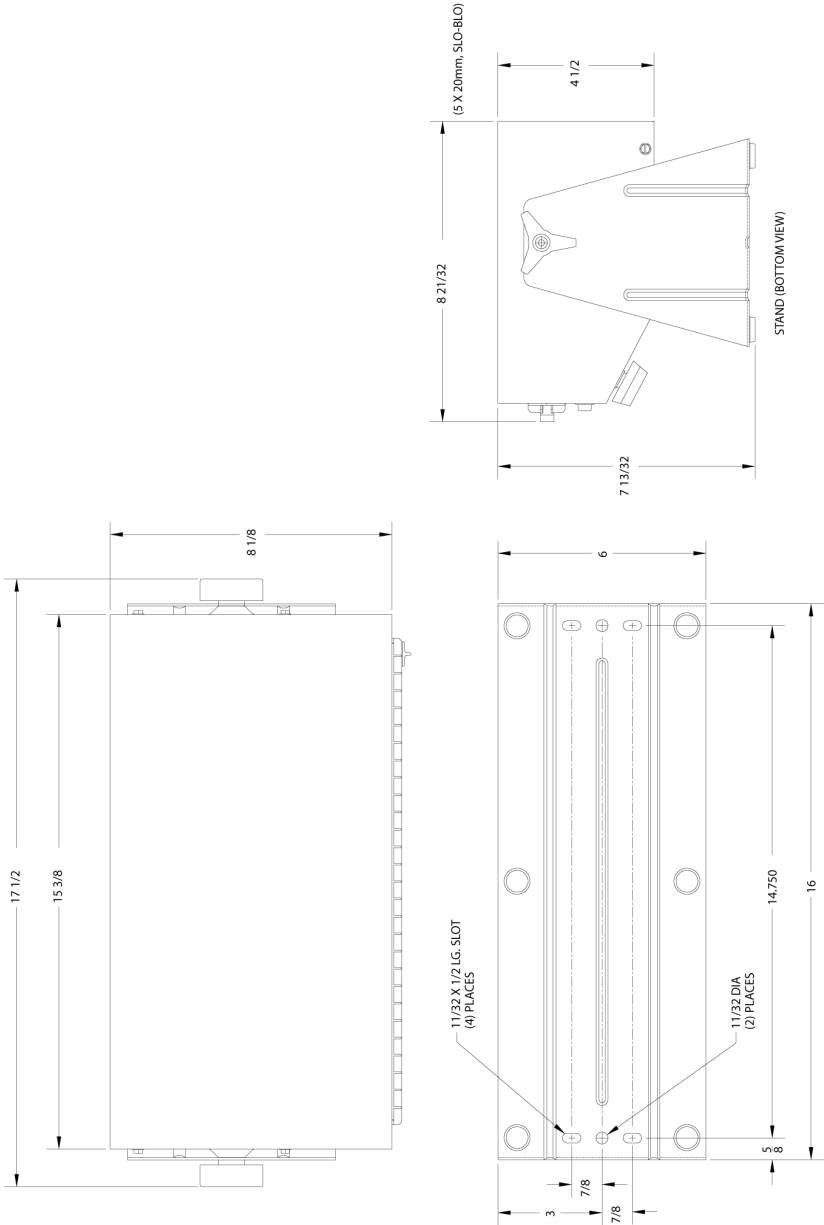

6

Warranty & Service

Simco-Ion provides a limited warranty for the Aerostat XC Ionizing Blower. New products manufactured or sold by Simco-Ion are guaranteed to be free from defects in material or manufacture for a period of two (2) years from date of initial shipment. Simco-Ion liability under its new product warranty is limited to servicing (evaluating, repairing, or replacing) any unit returned to Simco-Ion that has not been subjected to misuse, neglect, lack of routine maintenance, repair, alteration or accident. In no event shall Simco-Ion be liable for collateral or consequential damages. Consumable items such as, but not exclusive to, emitter points, emitter wires, batteries, filters, fuses or light bulbs are only covered under this warranty if found defective as received with the new product.

To obtain service under this warranty, please contact Simco-Ion Technical Support at techsupport@simco-ion.com or +1 (510) 217-0470.



SIMCOION™

An ITW Company

Technology Group

1141 Harbor Bay Pkwy, Ste 201

Alameda, CA USA 94502

Toll free: +1 800-367-2452

Sales services: +1 510-217-0460

Tech support: +1 510-217-0470

Fax: +1 510-217-0484

saleservices@simco-ion.com

techsupport@simco-ion.com

www.simco-ion.com