

TECHNICAL SPECIFICATIONS

VIDEO	
Resolution	800X600, 1024X768 , 1280X1024, 1366X768, 1920X1200, 480i, 720p, 1080i, 1080p and 3D
Color Depth	Deep Color 36/30/24 Bit at 1080p and 3D
Video Bandwidth	10.2 Gbps
Input Video Signal	1.2 Volts P-P
Input DDC Signal	5 Volts (TTL)

AUDIO	
Format	Up to PCM 8 channel, Dolby Digital TrueHD, and DTS-HD Master Audio
Input Interface	HDMI (Integrated)
Output Interface	HDMI (Integrated)

IR	
Signal Type	38kHz, 56kHz
Interface	3.5 mm Jack Socket (Female)

I/O CONNECTOR (Transmitter)	
Input	<ul style="list-style-type: none"> • HDMI-A 19PIN Socket • 12VDC Jack • 3.5mm Jacks for IR Receiver
Output	<ul style="list-style-type: none"> • RJ45 Jack • 3.5mm Jack for IR Emitter

I/O CONNECTOR (Receiver)	
Input	<ul style="list-style-type: none"> • RJ45 Jack • 3.5mm Jack for IR Receiver • 12VDC Jack
Output	<ul style="list-style-type: none"> • 3.5mm Jack for IR Emitter • HDMI-A 19PIN Socket

SYSTEM	
Interface	RJ-45
Cable Requirements	CAT5/5e/6
Maximum Length	250 ft.

OTHER	
Power	12VDC2.5A
Approvals	UL, CE, ROHS Compliant
Operating Temp.	32 to 104 °F (0 to 40 °C)
Storage Temp.	-4 to 140 °F (-20 to 60 °C)
Humidity	10% to 85% (Non-condensing)
Dimensions	0.9" x 2.9" x 3.7"
Weight	0.26 lbs



Designed and Manufactured in the USA

800.AVI.2131

Tel: (818) 503-6200 Fax: (818) 503-6208
11651 Vanowen St. North Hollywood, CA 91605

SmartAVI.com

Smart-AVI
SMART AUDIO VIDEO INNOVATION

HDX-POE



**HDMI, IR, and Power Extender
Over Single CAT5e/6 Cable**

Watch and control HDTV 1080p video up to
250ft from the source via Cat5e/6 using
HDBaseT and POE technology

USER MANUAL

OVERVIEW

Are you extending your HD signal reach and finding that the best potential new locations don't have the proper power available? You may not have to scale down your plans if you consider using an HDX-POE system from SmartAVI. HDX-POE injects power into HDBaseT CAT5/CAT6 cable that transports both HDMI and IR and picks it off at the load.

FEATURES

- Supports POE: Can be powered by TX or RX
- Extends HDMI,IR and Power Output over one Cat5e/6 Cable
- Extends IR Control Signals for Remote Control
- Uses HDBaseT Technology
- Full HD support: 1080p@60Hz@48 bit/pixels, 1080p@120Hz@24 bit/pixels, 3D, 1080P60Hz and 4K x 2K@30Hz@24bit
- Data Signals up to 3.4Gbps
- HDMI 1.4 and HDCP Compliance
- Uses Bi-Directional IR Communication
- Transmits High-Quality Dolby TrueHD, DTS-HD MA Audio Signals
- Transmits 1080p Resolution Video up to 250 ft

WHAT'S IN THE BOX?

PART NO.	DESCRIPTION
HDX-POES	HDBaseT HDMI & IR Extender over a Single Cat5e/6 Cable Includes: [HDX-POE-TX, HDX-POE-RX and (PS12V2.5A Wall Mount)]

APPLICATION DIAGRAM

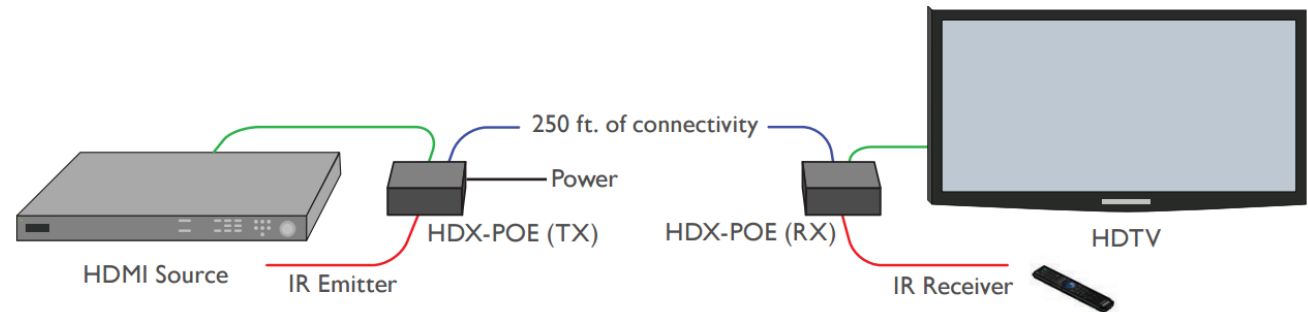

CONNECTING THE HDX-POE

1. Power off the HDMI source and display.
2. Connect an HDMI cable from the HDMI source to the HDMI IN port of the HDX-POE transmitter.
3. Connect an IR emitter (optional) to the IR OUT port on the transmitter.
4. Connect the HDX-POE transmitter to the HDX-POE receiver using a CAT5e/6 cable (up to 150ft).
5. Connect an IR receiver (optional) to the IR IN port on the receiver.
6. Connect an HDMI cable from the HDMI OUT port on the HDX-POE receiver to the HDMI Display.
7. Connect the power on the HDX-POE transmitter plugging in their power adapters (12VDC2A) or provide 12VDC input from the rear DC input port.
NOTE: If the RX side has connected DC adapter, TX can get the DC power over the CAT5e/CAT6 cable, so leave DC input port empty. Only 1 power supply is required for both units.
8. Power on the HDMI source, displays and speakers. The RX will read the EDID from the monitor, and then pass the data into the TX automatically.