

HDMI over CAT5 Extender



HLX-500

Chainable HDMI Extender via LAN

Break distance barriers to extend HDMI signals over IP using Cat5e/6 cables

OVERVIEW

The HLX-500 HDMI Extender gives users the freedom to extend HDMI signals via LAN, using inexpensive Cat5e/6 cables that many modern communications already rely on. This chainable extender can be used to generate thousands of feet of HDMI signal extension, breaking distance barriers. Users can set up their own extension cabling or utilize the pre-existing LAN infrastructure they have access to. Each unit extends signals up to 500 feet. With no software or driver required, users can easily extend HDMI signals such as HDTV, Blu-Ray, video game consoles and more. HLX-500 supports 1080p HD video up to 1920x1080 resolution at 60Hz and is Infrared Remote enabled.

The HLX-500 is a compact unit that is easily integrated into a digital display network at retail stores, restaurants, office spaces and many other venues. The transmitter and receiver units are small yet sturdy, which makes inclusion into any audio/video infrastructure quick and efficient.

The HLX-500 compresses data to utilize Cat5e/6 cables, but users will see no degradation of signal when using one gigabit Internet connections and up. For users utilizing pre-existing LAN connections, implementing a one gigabit switch allows for full resolution extension. Users with smaller bandwidth will experience compressed signals, if they so choose.

FEATURES

- Extends HDMI signal up to 500 feet via LAN (Cat5e/6 cables)
- Chainable for thousands of feet of extension
- Supports high resolution 1080p HD video, 1920x1080 at 60Hz
- Supports stereo audio
- IR (Infrared) remote enabled
- Bracket mountable
- No software or driver required
- Plug-and-Play ready

APPLICATION DIAGRAM

APPLICATION ONE

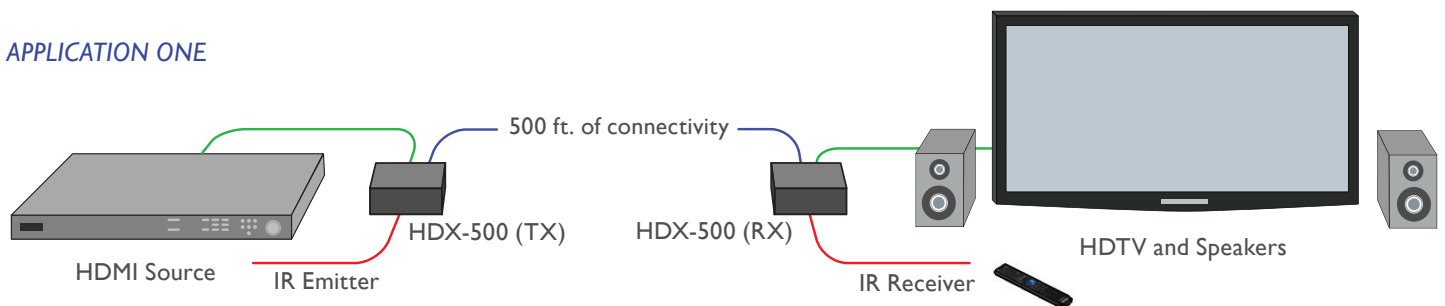

APPLICATION TWO

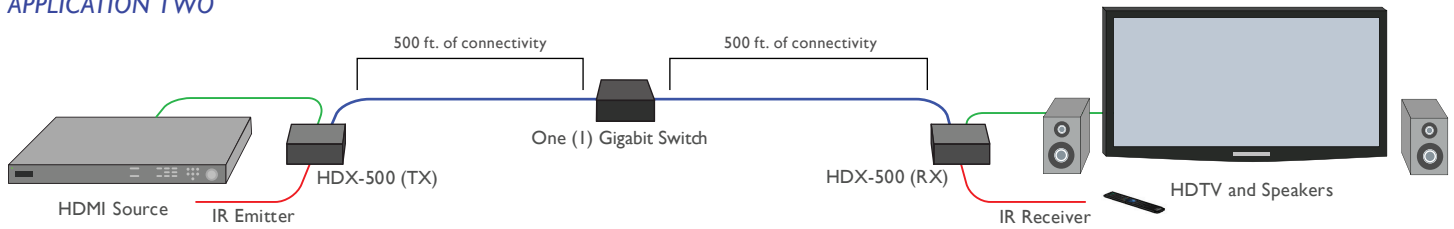

SPECIFICATIONS

VIDEO

Format	HDMI 1.3 and HDCP compliant
HDTV Resolutions	480p, 720p, 1080i, 1080p/60Hz/48bit
TV Resolution	480i
Input Interface (TX)	HDMI Type A 19-pin Female TMDS
Output Interface (RX)	HDMI Type A 19-pin Female TMDS
Input Cable Length (TX)	Up to 40 ft.
Output Cable Length (RX)	Up to 40 ft.

AUDIO

Format	Dolby TrueHD, DTS-HD MA
Input Interface	HDMI (Integrated)
Output Interface	HDMI (Integrated)

IR

Signal Type	38 KHz
Interface	3.5 mm Jack Socket (Female)

RS-232

Baud Rate	Up to 19,200 bps
Input Interface (TX)	DB-9 (Serial) Female
Output Interface (RX)	DB-9 (Serial) Male

HLX-500 (TX) Back



HLX-500 (RX) Back



HLX-500 (TX) Front



HLX-500 (RX) Front



SYSTEM

Interface	RJ-45
Cable Requirements	CAT5/5e/6
Maximum Length	500 ft.

OTHER

Power	External 100-240 VAC/5VDC2A @10W
Dimensions	4"W x 1"H x 4.357"D
Weight	0.6 lbs.
Approvals	UL, CE, ROHS Compliant
Operating Temp.	32-131°F (0-55 °C)
Storage Temp.	-4-185 °F (-20-85 °C)
Humidity	Up to 95%

Part No.	Description
HLX-500-S	HDMI, IR, RS-232 Point to Point CAT5 Extender. Includes: [HLX-500-TX, HLX-500-RX, 2 x (PS5VD2A)]



Designed and Manufactured in the USA

www.smartavi.com

Tel: 800.AVI.2131 • 818.503.6200 • 11651
Vanowen St. North Hollywood, CA. 91605

Smart-AVI
SMART AUDIO VIDEO INNOVATION