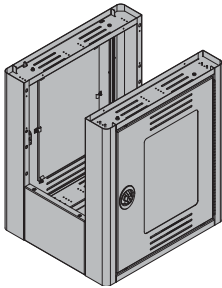


## Assembly Instructions

To purchase parts or accessories, please contact us at  
[www.spectrumfurniture.com](http://www.spectrumfurniture.com)  
 1-800-235-1262  
 Thank you for purchasing Spectrum products!

Before you begin, please make sure all parts and proper quantities are included. Any parts damaged during shipment must be reported within 15 days of receipt. To report information regarding damages or if you have any questions, please call 1-800-235-1262.



(1) 0112530  
 rack cabinet assembly



(8) 054544  
 1/4-20 x 1/2 flanged  
 hex head screw



(4) 0106543  
 1/4-20 keps nut



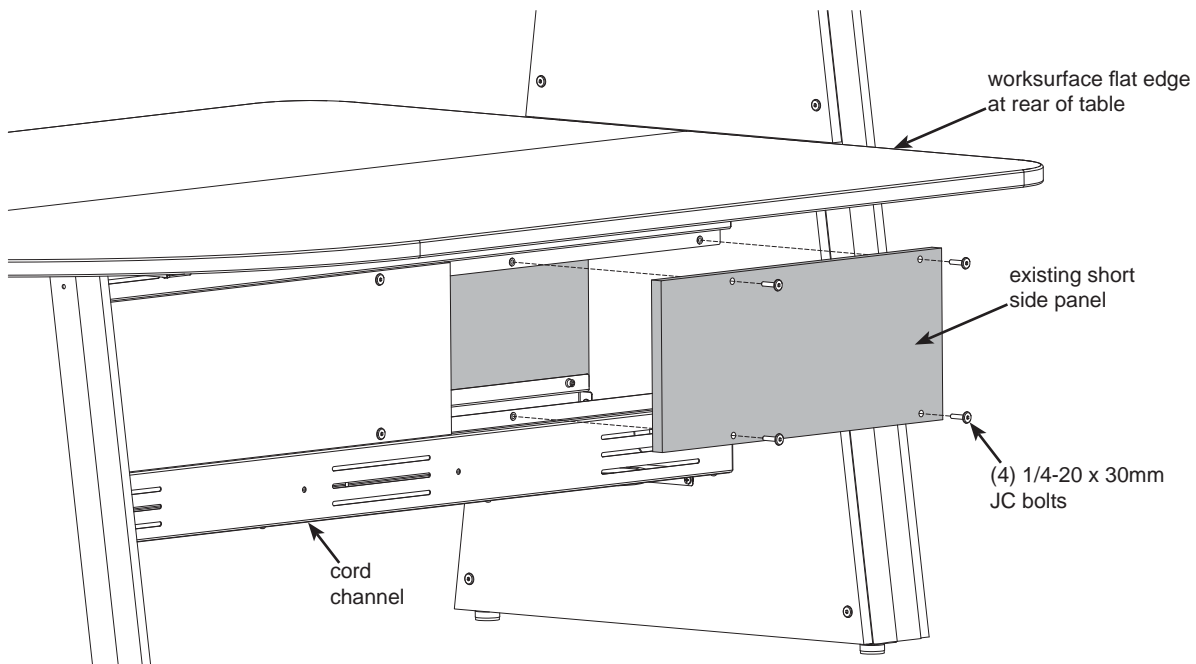
(1) 025039  
 4mm hex wrench

**Note:** If you are attaching this equipment rack to a new InVision table, attach the equipment rack to the table while the table is still upside-down during the table assembly (see InVision table assembly instructions). The following instructions show installation onto an upright table.

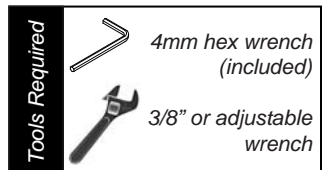
### 1. Remove short side panels

- A. Remove the (4) 1/4-20 x 30mm JC bolts to remove each short side panel from the existing cord channel. **Figure 1.**
- B. Remove the other short side panel on the opposite side of the cord channel using the same procedure.

**Note:** If the equipment rack will be permanent, these two panels will no longer be needed.

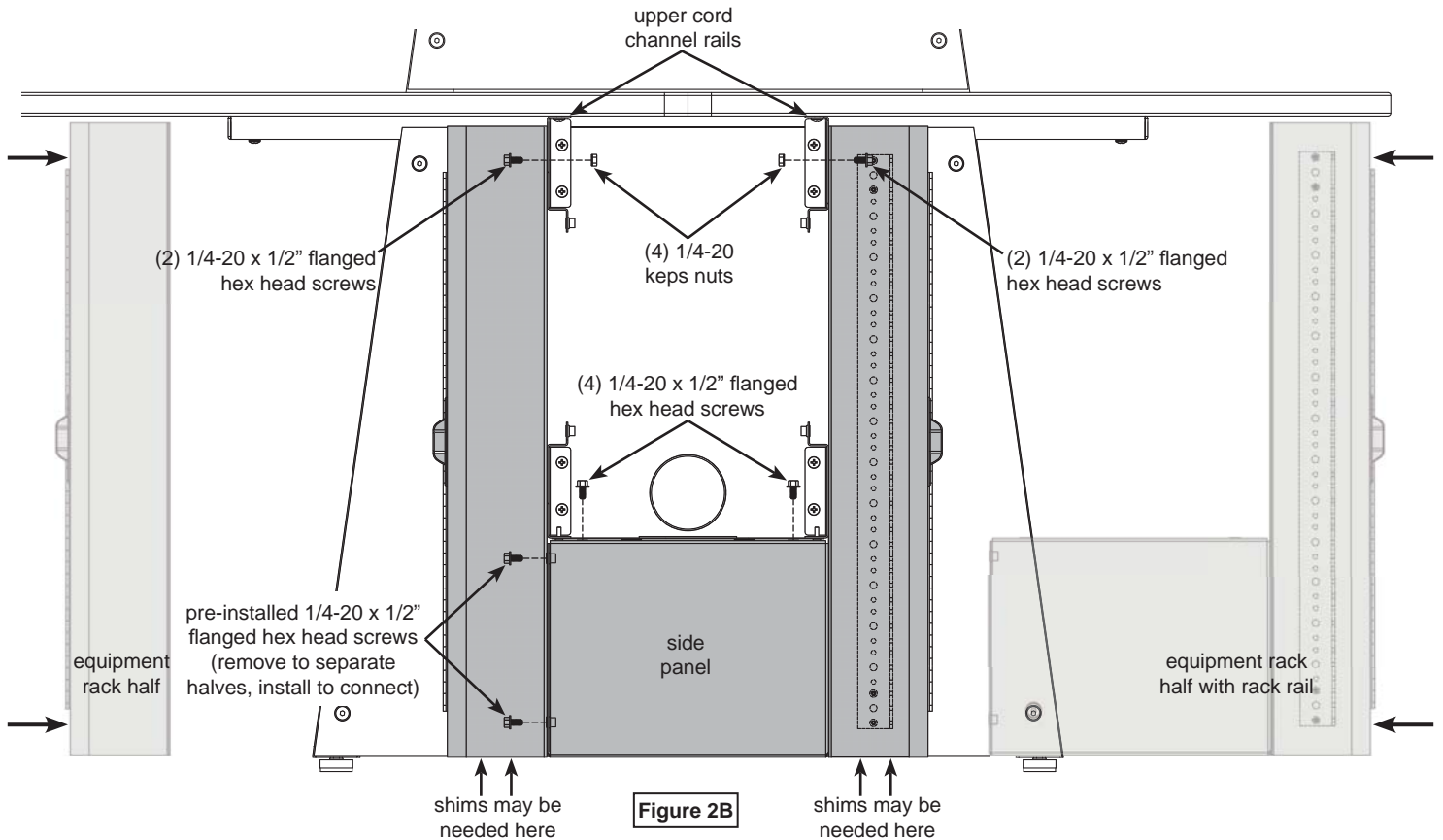


**Figure 1**



## 2. Attach equipment rack halves to cord channel

- A. Open the door on each equipment rack half. **Figure 2A.**
- B. Remove the four pre-installed 1/4-20 x 1/2" flanged hex head screws attaching the two halves together at the side panels.



- C. Align the equipment rack halves with the mounting holes in the cord channel as shown. **Figure 2B & 2C.** Note the hinge-side of each door will go toward the flat edge (or rear) of the table. If necessary, shims can be placed under the rack halves to lift and help align the mounting holes.
- D. Attach each equipment rack half to the upper cord channel with (2) 1/4-20 x 1/2" flanged hex head screws. **Figure 2B.**
- E. Install (2) 1/4-20 x 1/2" flanged hex head screws through the cord channel bottom panel into each equipment rack side panel. **Figure 2B.**
- F. Reattach the halves to each other at the side panels with the four previously removed 1/4-20 x 1/2" flanged hex head screws from step B.

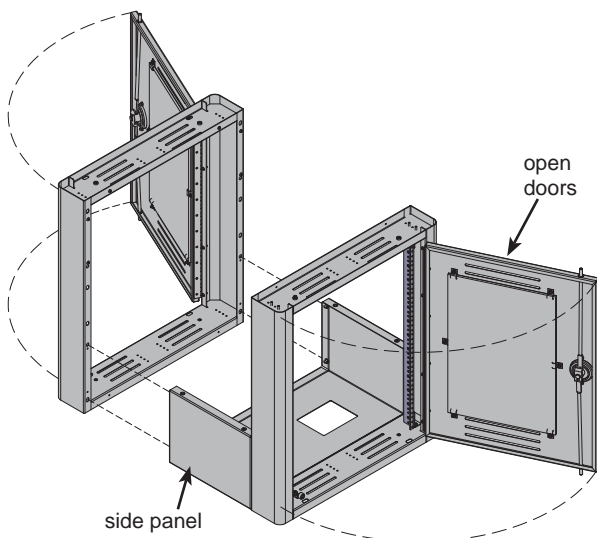


Figure 2A

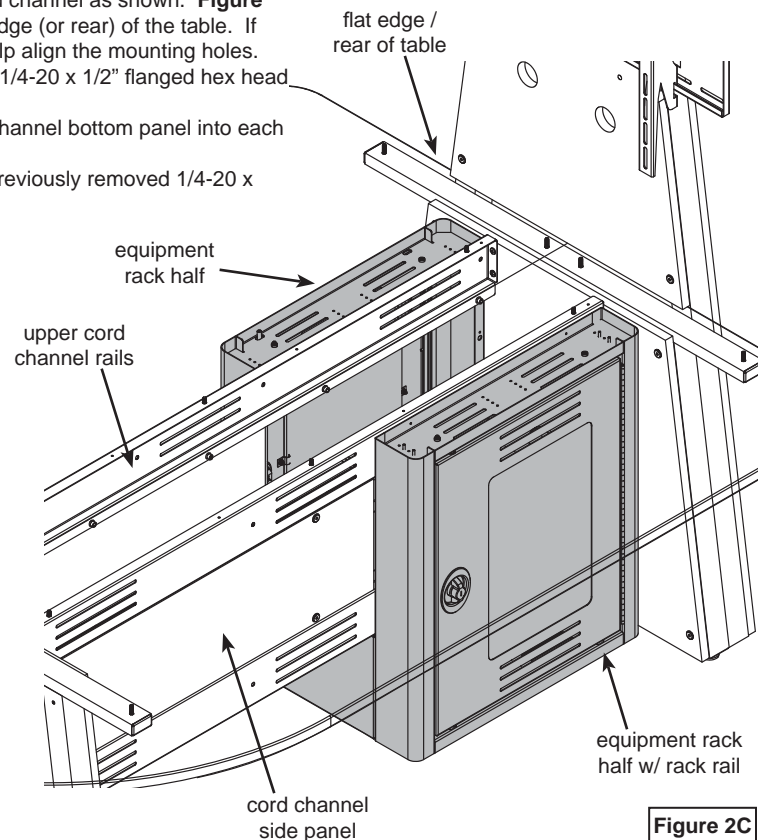
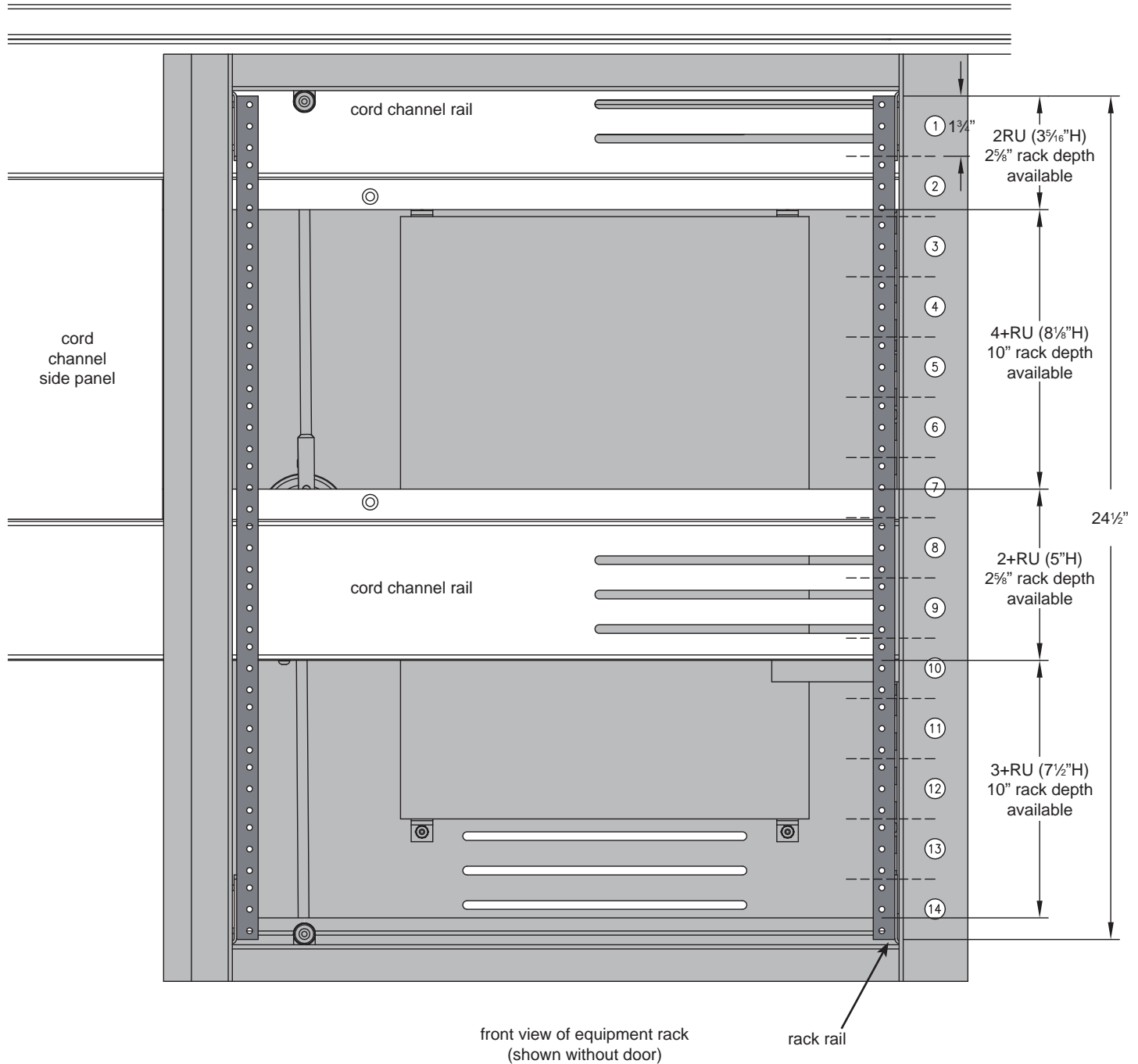


Figure 2C

## 3. Install rack-mount equipment

This equipment rack provides 7RU with up 10" of depth for rack-mount equipment. Approximately 4½ RU is available in front of the cord channel rails with a depth of 2⅝". This space directly in front of the cord channel rails can be used for fans, lights, or other rack-mount devices with a depth less than 2⅝". See **Figure 3** for dimensions.



**Figure 3**

# Warranty

## WE WILL MAKE IT RIGHT FOR YOU!

Spectrum is committed to provide complete customer satisfaction. Each of our products are manufactured from the best materials available and each product is stringently monitored throughout the production process through our P.A.C.E. program (Product Assurance to meet Customer Expectations). Our Customer Service Help Line 1-800-235-1262 is ready to provide immediate attention to any questions, comments or concerns. We are available to answer your calls Monday through Friday from 7 am to 5 pm CST, excluding observed holidays. In addition your product comments or concerns are welcome via e-mail at: [spectrum@spectrumfurniture.com](mailto:spectrum@spectrumfurniture.com).

## Warranty Statement

We guarantee all Spectrum products to be free of all defects in materials and workmanship, for the original owner, for a period of ten years. Any item deemed defective by Spectrum or the original manufacturer, under normal use conditions, will be repaired or replaced at Spectrum's discretion. This warranty applies to all products manufactured and distributed by Spectrum except the products listed below.

Items that have a varying warranty include, but are not limited to, the following:

- Adjustable Crank/Electric Desk Legs (1 yr)
- Flat Panel Desk Gas Cylinders (1 yr)
- Upholstered Soft-Goods (5 yrs)
- Adjustable Height & Stacking Chair Parts – including frames, gas cylinders, wood and plastic parts, and control handles (7 yrs)
- Adjustable Height & Stacking Chair Casters (2 yrs)
- Chair Upholstery & Textiles (2 yrs of normal use of Soft Goods, Adjustable Height, Stacking, Wood and Metal Chairs)
- Chair Upholstery - Graded-In Fabrics and C.O.M (no warranty)
- Height Adjustable Columns and Lifts (1 yr)
- General Use Casters (1 yr)
- Electrical – Electri-Pak, Power Communication Modules, and special order ECA electrical items (1 yr)
- Electrical - Power Strips & Electrical Timers (1 yr)
- Electrical Surge Suppressors (lifetime)
- Electrical - Retractable Power Cords (1 yr)
- Keyboard/Mouse Trays (1 yr)
- Flat Panel Monitor Arm – General Parts (5 yrs)
- Flat Panel Monitor Arm – Gas Cylinders (2 yrs)
- CRT Monitor Arm (1 yr)

Warranty is void if product is not used for its intended purpose or subjected to an unusual application, multiple-shift use, alteration, accident, abuse or abnormal wear and tear. Representations of colors on-line and in printed materials are meant to be a close reference to the actual colors but not an exact match. Slight variations in color and texture of wood stains, powder coating, laminates, fabrics and other materials are normal in different manufacturing lots; as such these variations are not considered defects.

**DESIGNED FOR INDOOR USE ONLY** – Unless specifically stated in the product specifications, Spectrum's products have been designed and constructed for indoor use only. Moving or using outdoors, or on excessively rough surfaces, may cause damage to the products and will void the warranty. If an outdoor application is desired please contact us to discuss potential custom design solutions.

**The warranty, as stated above, supersedes any previous warranties and is effective as of 9/1/2010**

