

Assembly Instructions

⚠ Important ⚠

Before you begin, read and comply with all safety and operating instructions, and ensure all parts and correct quantities are included.

Any parts damaged during shipment must be reported within 5 days of receipt. To report information regarding missing parts or damage, to purchase parts or accessories, or if you have any questions, please contact us.

www.spectrumfurniture.com
800-235-1262, 715-723-6750

Thank you for purchasing Spectrum products!

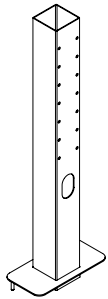

(1) 0118510
Upright assembly

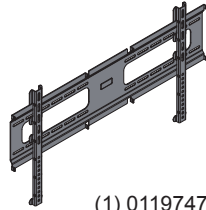

(1) 0119747
Monitor mount

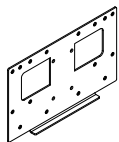

(1) 0131924
Upright bracket



(12) 052605
1/4-20 x 15mm
JC bolt

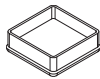

(1) 0118193
End cap 3" x 3"

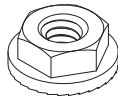

(4) 0108896
1/4-20 Flanged
serrated locknut

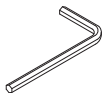

(1) 025039
4mm Hex wrench

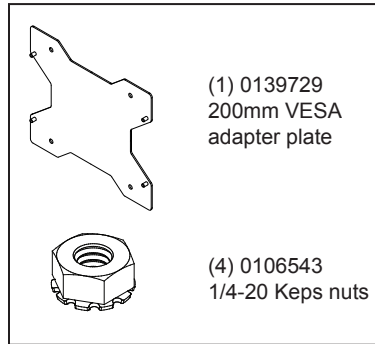

(1) 0139729
200mm VESA
adapter plate

(4) 0106543
1/4-20 Keps nuts

Tools Required



4mm Hex wrench
(included)



7/16" or Adjustable
wrench

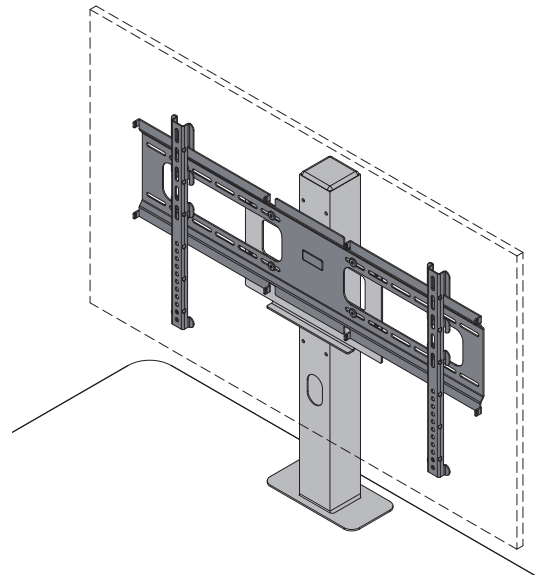

Display Stand 37130

Installation

1. With the upright assembly upside-down, remove the rubber thread protector from each threaded stud. **Figure 1.** (A utility knife may be needed to cut off.)

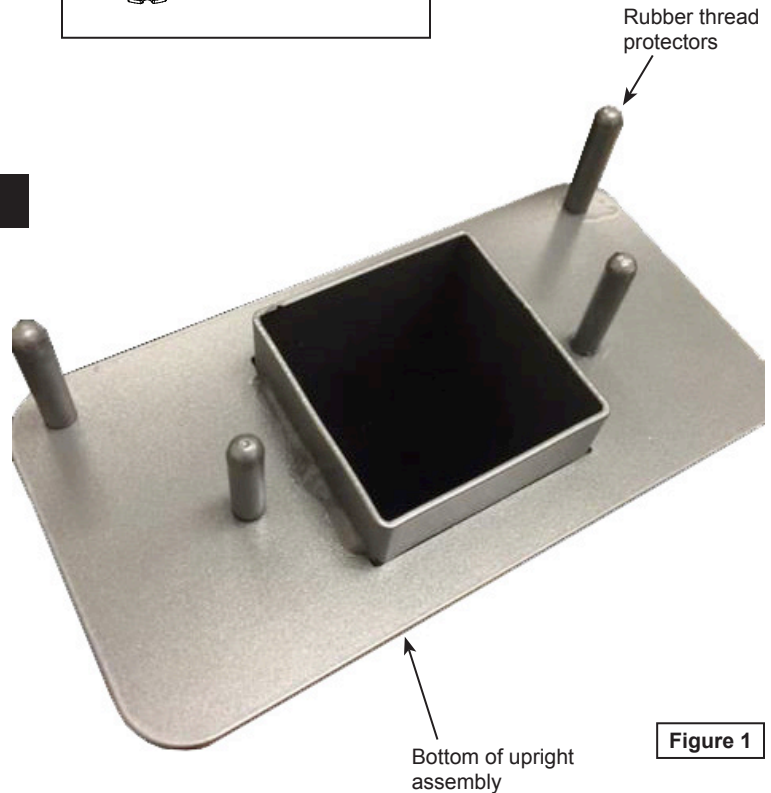
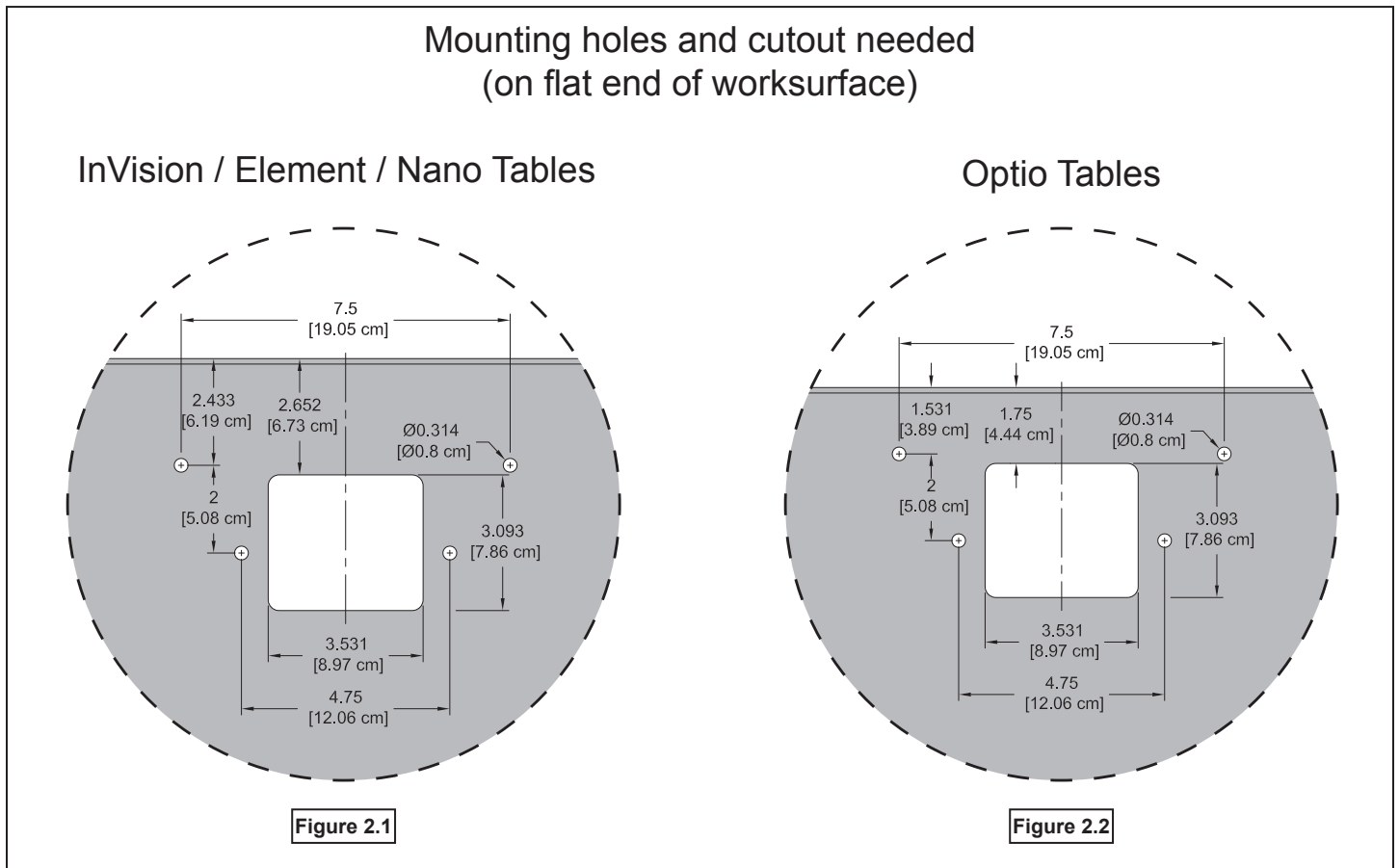

Figure 1

- Be sure the worksurface being used has the cutout / hole pattern shown in **Figure 2.1**, or **Figure 2.2**.



- An unattached worksurface will facilitate installation of the display stand fasteners. If attached, remove the worksurface fasteners securing it to the base and slide the worksurface 6" over the base to provide access to the display stand mounting holes. **Figure 3**.
- Align the studs and insert the upright into the worksurface mounting holes.
- With a second person holding the upright, Install (4) 1/4-20 Flanged serrated locknuts and tighten securely.

Note: For InVision Nano table installation, see p.3 for special instructions.

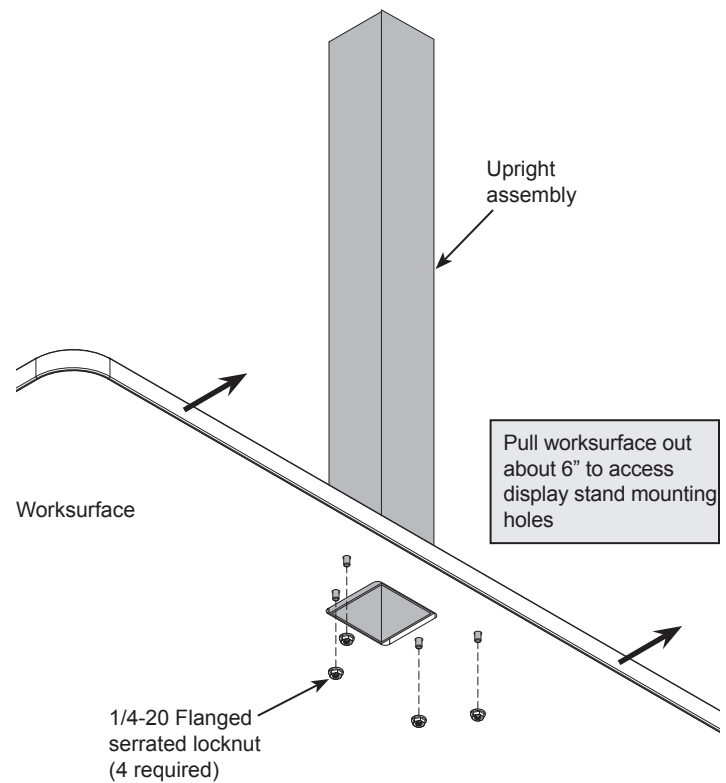

Figure 3

- Attach the upright bracket to the upright assembly as shown using (4) 1/4-20 x 15mm JC bolts and tighten securely. (Multiple mounting holes / height positions are available on the upright assembly). **Figure 4.**

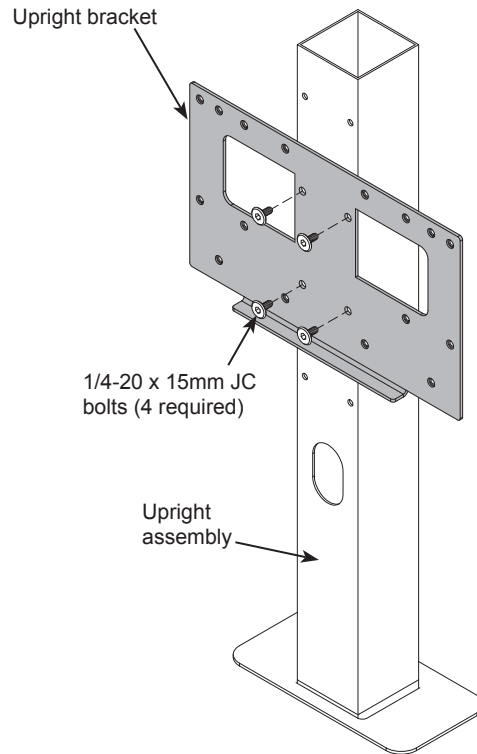

Figure 4

Install monitor

- Refer to the instructions included with the monitor mount for complete monitor and security rod installation procedure.
- The assembled display stand accommodates most 37"-70" monitors.
- Be sure your monitor does not exceed the weight capacity of 125 lb.

- Refer to the instructions included with the monitor mount for complete monitor installation procedure.
- Install the monitor mounting plate to the upright bracket with (4) 1/4-20 x 15mm JC bolts and tighten securely. **Figure 5.**
- Install monitor and route wiring through the upright opening.
- Install end cap on top of upright.

⚠ WARNING ⚠

The monitor should always be removed from the stand before moving the table.

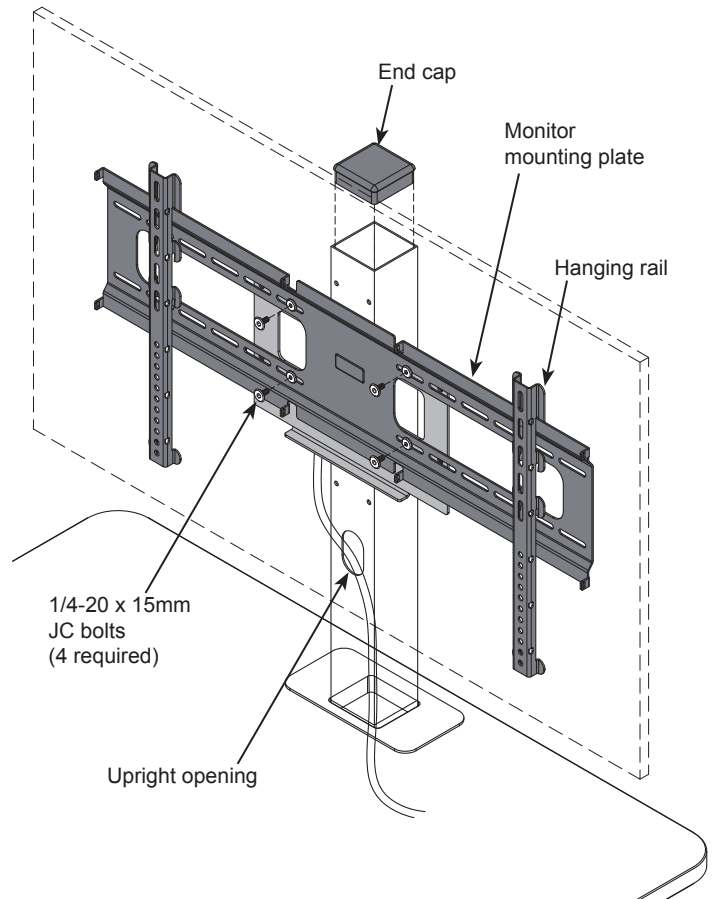
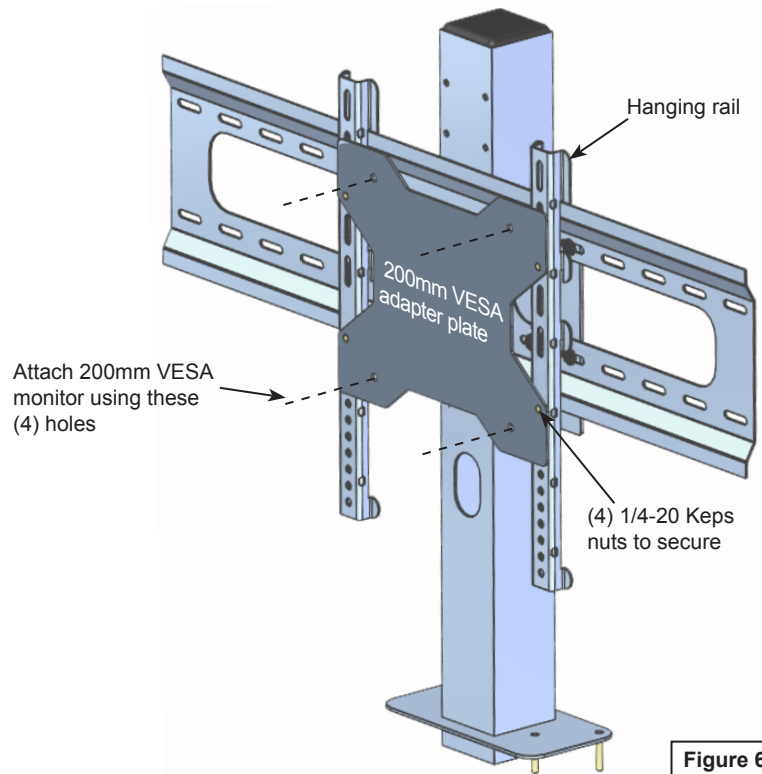

Figure 5

200mm VESA adapter plate (optional)

Note: The included adapter plate is for 200mm VESA monitor applications. To install, align the adapter plate posts with the hanging rail mounts and secure with 1/4-20 Keps nuts.



InVision Nano Table Installation only

Note: To install the Display Stand on a Nano table, the end panel must be removed prior to installing.

1. Remove the (4) screws shown. **Figure 7.1.**
2. Remove end panel.

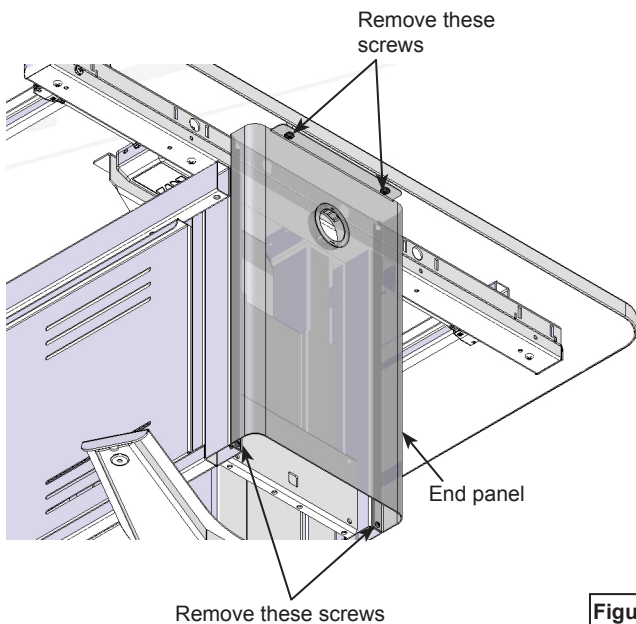

3. Align the studs and insert the upright into the worksurface mounting holes.
4. With a second person holding the upright, install the (2) inner 1/4-20 Flanged serrated locknuts. **Figure 7.2.**
5. Replace the end panel.
6. Install the (2) outer 1/4-20 flanged serrated locknuts.
7. Tighten all locknuts securely.

