

Assembly Instructions

⚠ Important ⚠

Before you begin, read and comply with all safety and operating instructions, and ensure all parts and correct quantities are included.

Any parts damaged during shipment must be reported within 5 days of receipt. To report information regarding missing parts or damage, to purchase parts or accessories, or if you have any questions, please contact us.

www.spectrumfurniture.com
800-235-1262, 715-723-6750

Thank you for purchasing Spectrum products!

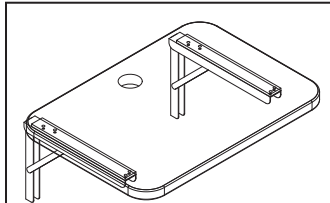

Flip-up Shelf Assembly

- | | |
|-----------------------------|---------------------------|
| (1) 0119425
Worksurface | (2) 0109646
Shelf shim |
| (2) 056886
Shelf bracket | (8) #8 x 1"
PHSM screw |

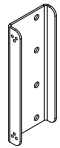

- (2) 0135022
Channel bracket

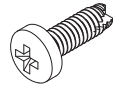

- (4) 0100167
8-32 x 1/2" PH
Thread-cutting
screw

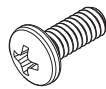

- (2) 026064
1/4-20 x 5/8"
PHMS

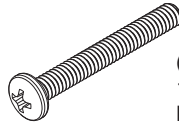

- (2) 0190564
1/4-20 x 2-1/2"
PHMS



- (2) 0106543
1/4-20 Keps nut



- (1) 039622
2" Grommet

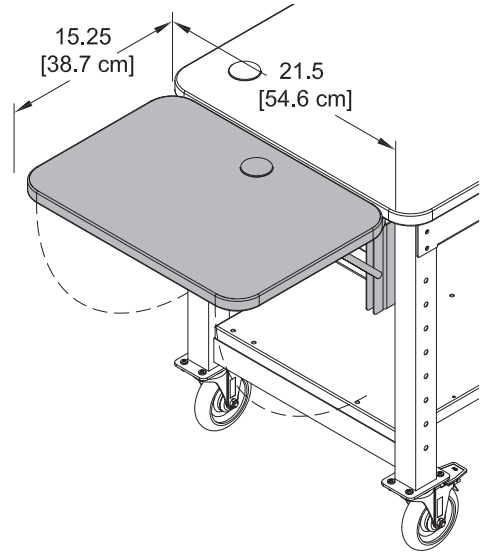

Flip-up Shelf for 3D2GO™ Printer Cart 37137

Note: Only one flip-up shelf, or one handle will attach to each side-not both at the same time.

Tools Required
 Phillips
Screwdriver

1. Installation

- Determine the side of the unit the shelf will go on. (Left or right).
- Align each channel bracket with the leg mounting holes. **Figure 1**. (The two sets of 3 smaller holes will face outward.)
- Install (1) 1/4-20 x 5/8" PHM screw at the top of each bracket.
- Install (1) 1/4-20 x 2-1/2" PHM screw and Keps nut on the bottom of each bracket.

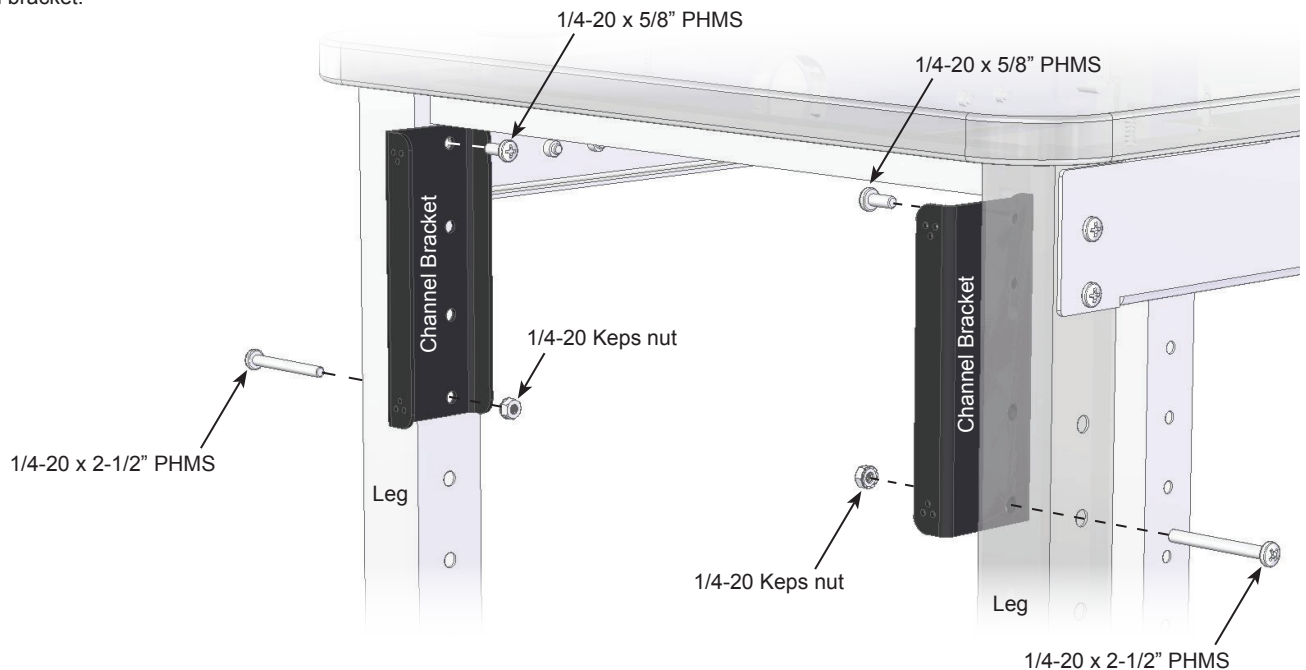

Figure 1

Touchboards

205 Westwood Ave, Long Branch, NJ 07740
Phone: 866-94 BOARDS (26273) / (732)-222-1511
Fax: (732)-222-7088 | E-mail: sales@touchboards.com

2. Attach Flip-up shelf assembly

1. Extend both shelf brackets fully.
2. Align the brackets with both sets of "tri-holes" as shown.
3. Attach the shelf with (4) 8-32 x 1/2" PH thread-cutting screws using the holes shown. **Figure 2.1** and **Figure 2.2**.
4. Tighten screws securely.
5. Install 2" grommet.

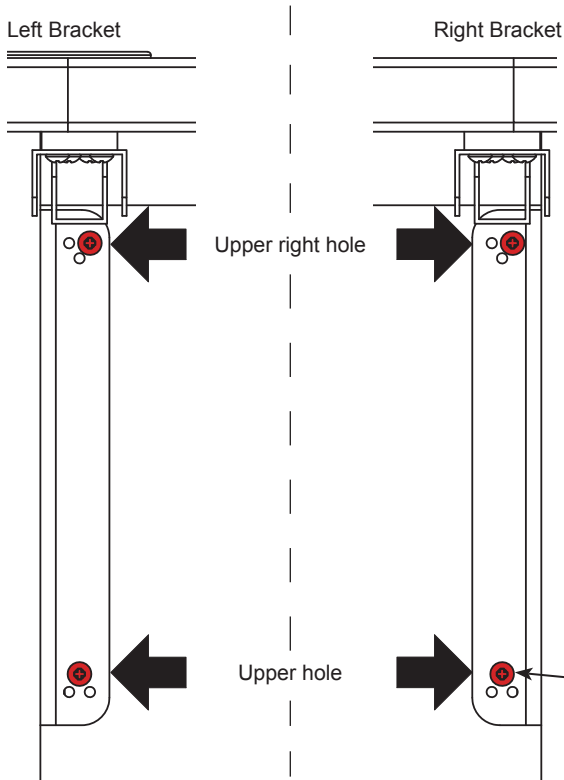

Figure 2.1

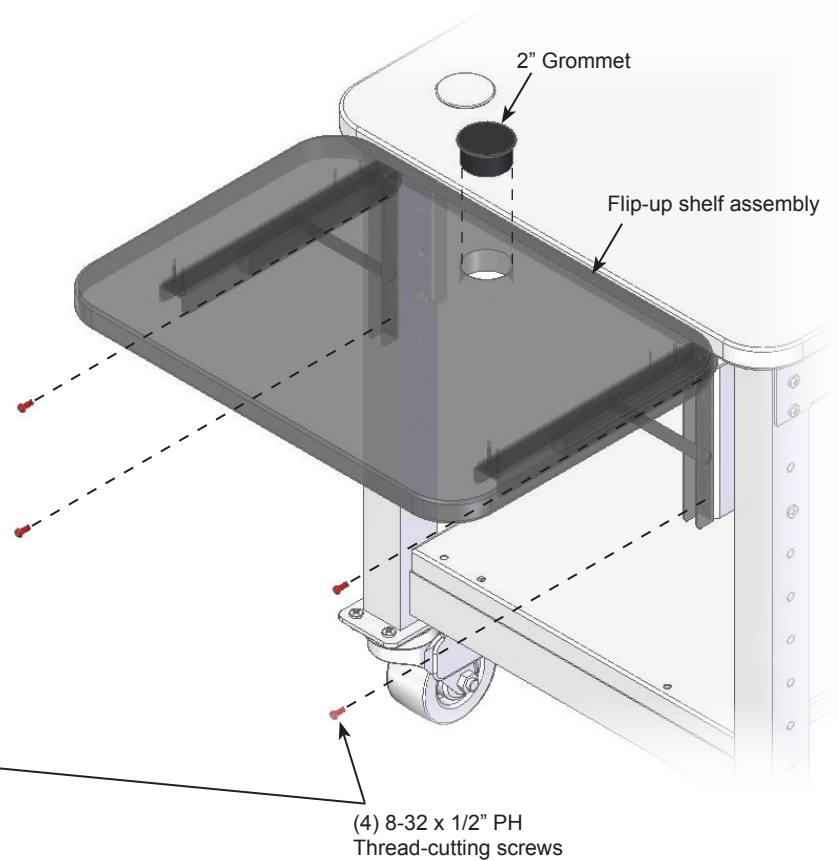

Figure 2.2

3. Operation

The shelf will automatically lock into place when lifted into the horizontal position with the levers released. **Figure 3**. To lower or flip-up the shelf, press and hold the levers under each folding shelf bracket at the same time while slowly lowering or raising the shelf. Do not exceed a maximum of 25 lb of weight on the shelf. Do not move the unit while the shelf is in the horizontal position.

Note: Wiring for document cameras or laptop computers placed on the flip-up shelf should be routed on top of the audience-side of the shelf. Use of the shelf grommet hole for wiring will result in pinching of the cords when the shelf is folded.

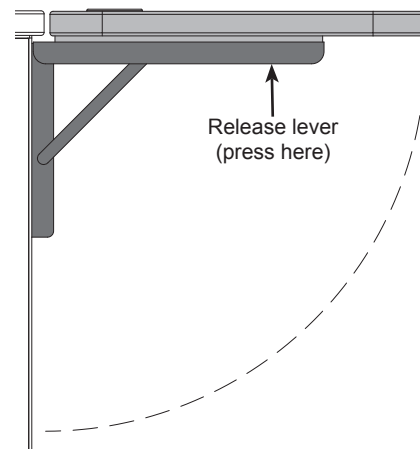
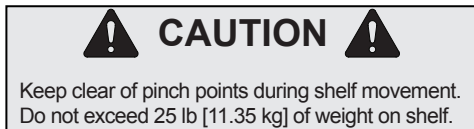

Figure 3