

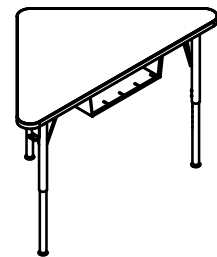

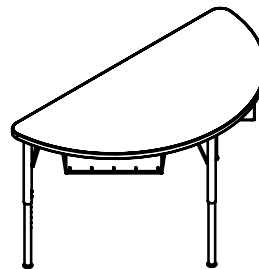

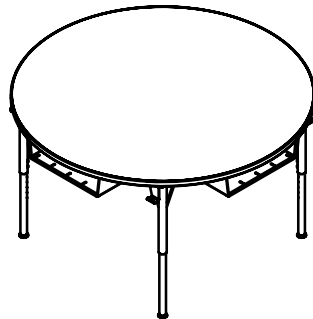

Aspire Table™

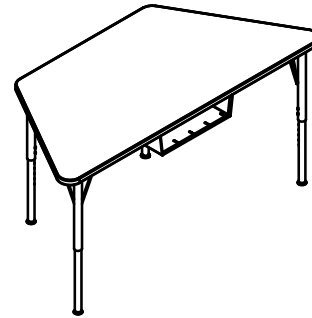
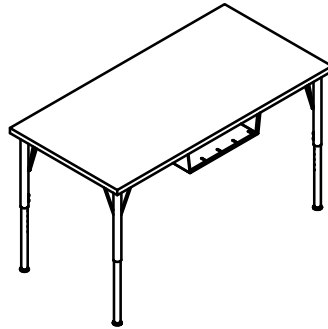

	Product #
Rectangular table	37320
Round table	37321
Half-round table	37322
Trapezoid table	37323
Triangular table	37368



 Important 	 Important 	 Importante 
<p>Before using this product:</p> <ul style="list-style-type: none"> • Read this manual • Comply with all safety and operating instructions • Ensure all parts and correct quantities are included <p>Any parts damaged during shipment must be reported within 5 days of receipt. To report information regarding missing parts or damage, to purchase parts or accessories, or if you have any questions, please contact us.</p> <p>Thank you for purchasing Spectrum products!</p>	<p>Avant d'utiliser ce produit:</p> <ul style="list-style-type: none"> • Veuillez à lire ce guide • Respectez les consignes de sécurité et d'utilisation • Vérifiez que vous disposez de toutes les pièces nécessaires à l'installation <p>Les pièces endommagées pendant le transport doivent faire l'objet d'un rapport dans les 5 jours de leur réception. Veuillez prendre contact avec nous si des pièces manquent ou sont abîmées, si vous avez des questions, ou encore pour acheter des pièces ou des accessoires.</p> <p>Merci pour votre achat d'un produit Spectrum!</p>	<p>Antes de utilizar este producto:</p> <ul style="list-style-type: none"> • Lea este manual • Cumpla con todas las instrucciones de prevención de accidentes y operativas • Revise que todas las partes y las cantidades correctas estén incluidas <p>Si alguna parte se dañó durante el embarque, deberá reportarla en un lapso de 5 días a partir de la recepción. Para reportar cualquier información sobre partes faltantes o dañadas, para adquirirlas o comprar accesorios, o bien, si tiene alguna duda, póngase en contacto con nosotros.</p> <p>¡Gracias por adquirir productos Spectrum!</p>



<http://www.spectrumfurniture.com>

 Owner's Manual Le manuel du propriétaire El manual del propietario	 Specs Spécifications Especificaciones	 Video Vidéo Vídeo
--	---	---



 800-235-1262

Tools

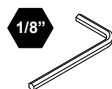

1 Attach legs to worksurface

2 Install glides or casters

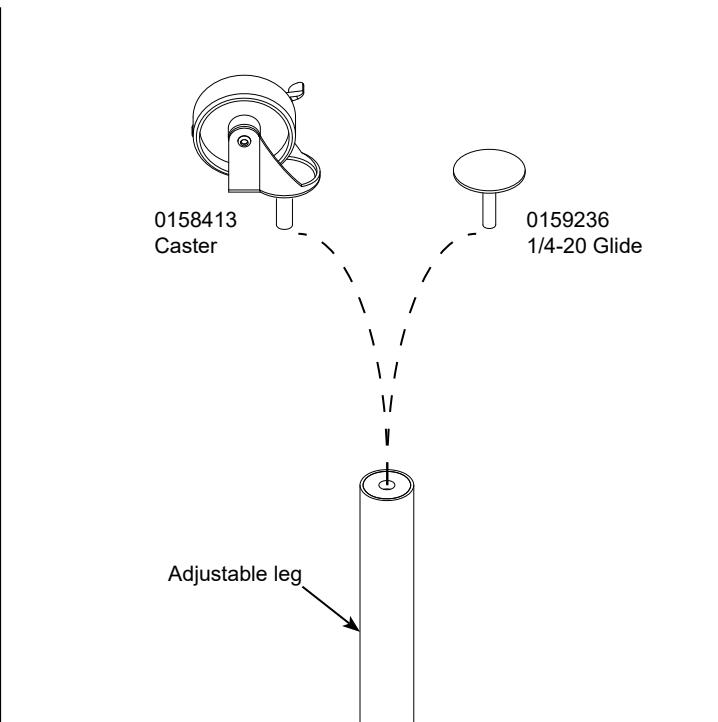
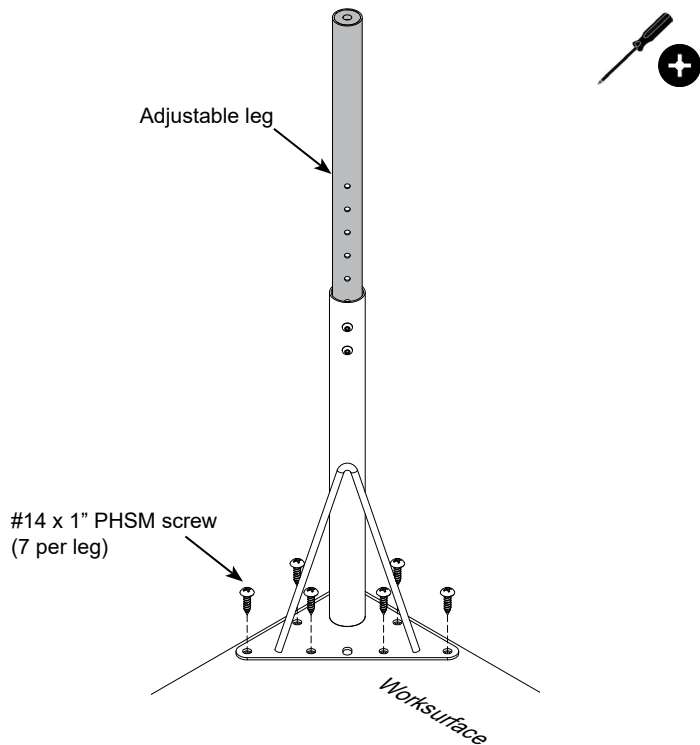

3 Adjust leg height

4 Flip table upright

5 Locking casters

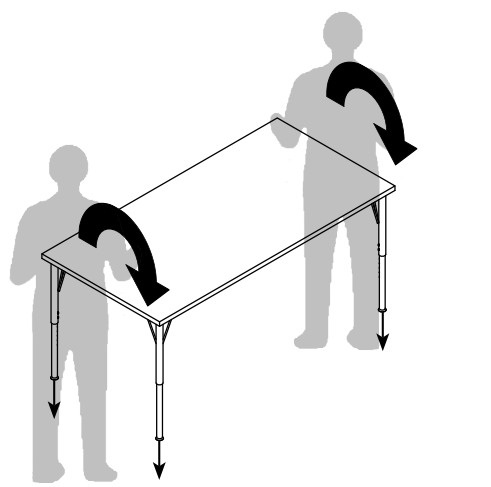
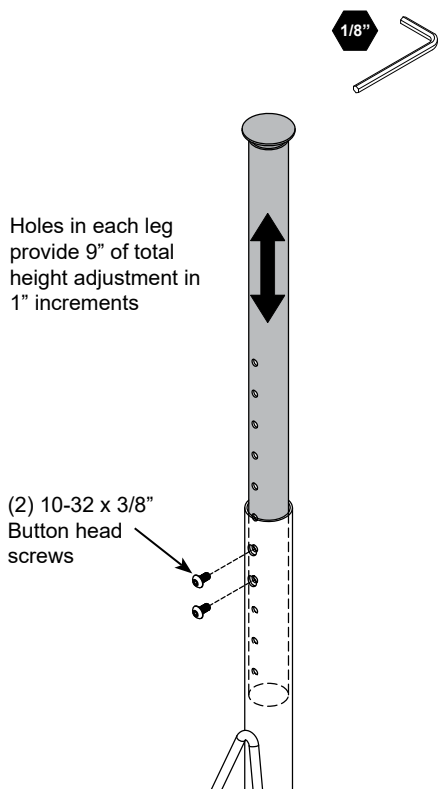

CAUTION

Do not allow the table legs to contact the floor until the table is completely flipped over. Side-loading of the legs could cause damage.

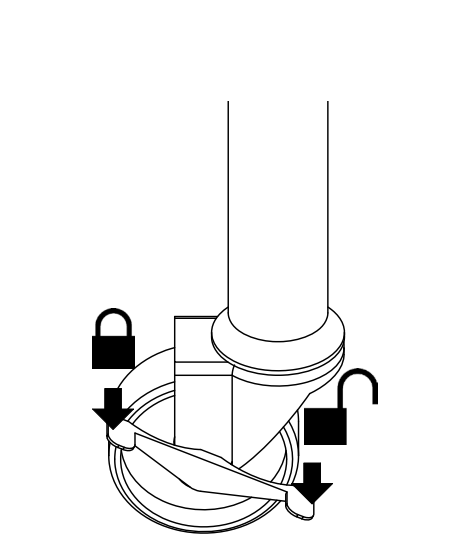

Accessories

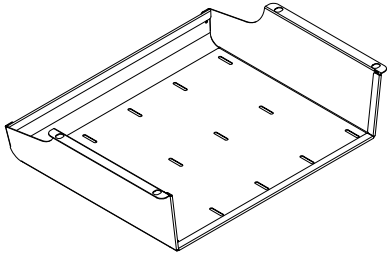

Tray - 37369

- Provides storage under worksurface for supplies
- 15.15"W x 12.625"D x 4"H
- Black powdercoat
- 20ga steel
- Each tray installs with (4) included screws

Note: When tray is installed, the knee clearance height of the table will no longer be ADA-compliant

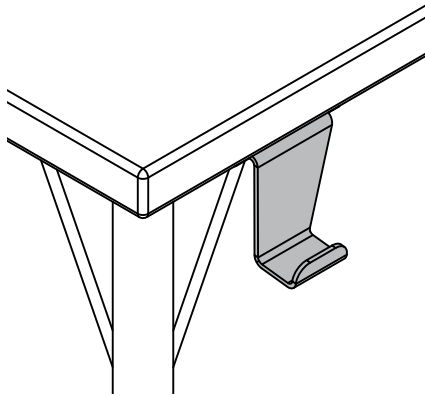

Backpack Hanger Bracket - 37370

- Includes (one) bracket
- Available in all metal colors
- 12 ga steel
- Each hanger bracket installs with (2) included screws
- Each Aspire leg can support up to two brackets

See spectrumfurniture.com for the latest accessories and detailed warranty information.



Important Safety & Care Information



- Read this owner's manual before assembly or operation.
- Do not allow children to move the table.
- For indoor use only. Do not install or store the table where it will be exposed to moisture.
- Do not block the ventilation openings.
- Do not allow anyone to sit, stand, or climb on the table.
- Use a damp, soft-cloth, or sponge, with mild soap or detergent solution to clean dirty surfaces. Do not use harsh solvents or abrasives.
- This table is intended for institutional use. It does not have any user-serviceable parts or user-maintenance requirements. If servicing is necessary, please contact Spectrum Industries for assistance.

Warning - Relocating audio and/or video equipment to furniture not specifically designed to support audio and/or video equipment may result in death or serious injury due to the furnishing collapsing or over turning onto a child.

Warning - Death or serious injury may occur when children climb on audio and/or video equipment furniture. A remote control or toys placed on the furnishing may encourage a child to climb on the furnishing and as a result the furnishing may tip over on to the child.

General Electrical Safety:

- Keep power switches in the OFF position before plugging or unplugging from the wall outlet.
- Be sure total device / equipment load does not exceed 12-amps.
- Do not plug power cords into an extension cord.
- Inspect power cords for damage before each use. Do not use cords that are damaged.
- Unplug power cord from electrical outlet by gripping the cord-do not unplug by pulling only on the cord.
- Do not step on, drive over, drag, or place objects on power cords.
- For added safety, plug into a grounded outlet controlled by a GFI (Ground Fault Interrupter) circuit breaker.
- Damaged electrical components can create significant hazards to users and is not covered by the warranty. Repairs should always be performed by a qualified electrician.
- Electrical devices are not toys. Children are often unaware of the hazards associated with electrical devices. This table must always be used by adults or with adult supervision.

Warranty

We will make it right for you!

Thanks for choosing Spectrum! Spectrum is committed to provide complete customer satisfaction. Each of our products is manufactured from the best materials available and each product is stringently monitored throughout the production process through our P.A.C.E. program (Product Assurance to meet Customer Expectations).

We expressly warrant that Spectrum products will be of good quality and workmanship and free from defect for the period set out in the warranty from the date of delivery.

For a listing of all product specific warranty terms please visit our website at:

<https://www.spectrumfurniture.com/en/resources/purchasing-terms-warranty>

1-800-235-1262

Toll-free HELPLINE

spectrum@spectrumfurniture.com



Spectrum Industries is Certified ISO 9001:2015