

## Technical Specifications

	Product #
Rectangular table	37320
Round table	37321
Half-round table	37322
Trapezoid table	37323
Triangular table	37368

Discounts available in bulk pack quantities of 8 or more. Contact Spectrum for more information.

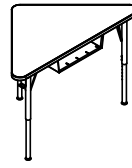
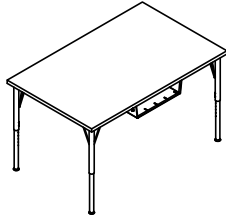
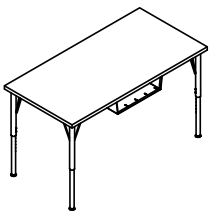

Triangular

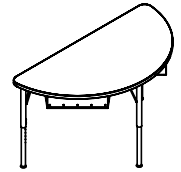
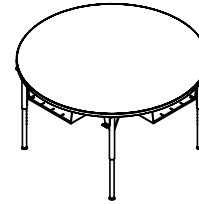
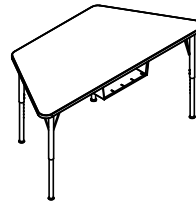
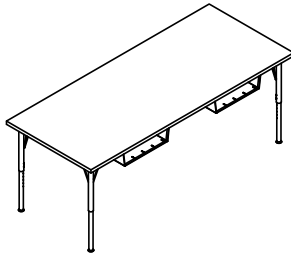
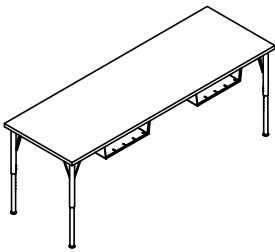
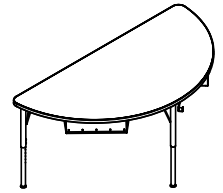
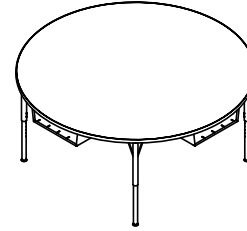
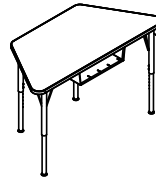
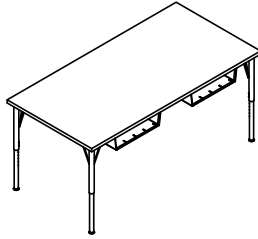
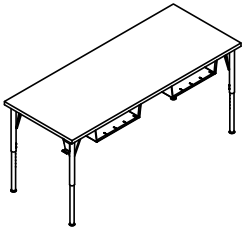

Rectangular

Trapezoid

Round

Half-round

Spectrum's Aspire Tables were designed with room reconfiguration in mind. These durable, all-purpose tables are designed for use in a wide variety of applications such as classrooms, training/conference rooms, and computer labs. Optional casters provide quick and easy reconfiguring of any room.

Tables shown with optional trays and backpack hanger brackets.

## Features and Benefits

- Available in 72", 60", 48", and 32" wide versions
- Available in 30" or 24" depths
- Rectangular, round, half-round, triangular, and trapezoid worksurface shapes available
- Steel legs provide 9" of height adjustment
- Available with stationary glides or locking casters for easy room reconfiguration
- Scratch and impact-resistant high-pressure laminate worksurface
- Steel worksurface brace provides support and minimizes flexing (all sizes)
- Matching vinyl edge trim on worksurface edges (some laminate choices use non-matching edge trim)
- Optional hanger bracket provides a place to hang backpacks or purses
- Optional tray provides storage under worksurface for supplies

- Standard laminate colors available to match existing furniture
- Table ships "knocked-down" for lower shipping costs and can be easily assembled at the final location
- Warranted to be free of all defects in materials and workmanship for 10 years
- Designed and assembled in Chippewa Falls, WI, USA

### Color Options

Worksurface laminate:



Wild Cherry (CH)



Fusion Maple (FM)



Graphite Talc (GT)

Metal adjustable leg:

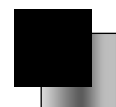

Black upper, chrome lower

Matching edgeband

Black edgeband

### Ordering Instructions

Spectrum has designed this product to receive the useful options shown here. To ensure your options are ordered correctly please call 1-800-235-1262.

# Construction

- The worksurface is constructed from 1" thick composite board with .030" [.762mm] high-pressure laminate on one face, and a balancing backer on the opposing face
- Worksurface edges are covered with vinyl edgeband
- The formed worksurface brace is 14-gauge steel
- All metal components are finished with a scratch-resistant powder coat epoxy
- All tables are shipped knocked-down (KD) and require assembly
- Bulk packaging available for quantities of 8 or more. Access to a truck-height loading dock, forklift, liftgate truck, or other means of unloading a heavy shipment is needed.

Worksurface edge

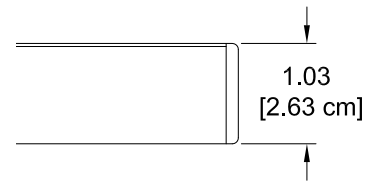

# Specifications

Worksurface height ( <i>adjustable legs</i> )	23.7" - 32.7"H [60.13 - 82.98 cm] (w/ casters) 21.4" - 30.4"H [54.25 - 77.11 cm] (w/ glides)	(9" of adjustability in 1" increments)
Casters ( <i>caster-versions only</i> )	Hard polyurethane, with brake Weight capacity: N/A	
ADA-compliance*	 1 ADA seat per table <i>*Minimum ADA guidelines for knee clearances are 30"W x 19"D x 27"H</i>	
Certifications / Compliance	<ul style="list-style-type: none"> <li>• SCS Indoor Advantage Certified-Pending</li> <li>• Meets or exceeds applicable ANSI-BIFMA test standards</li> </ul>	
Shipping	<i>Bulk packaging available for quantities of 8 or more. Access to a truck-height loading dock, forklift, liftgate truck, or other means of unloading a heavy shipment is needed.</i> <i>Note: Weights of bulk packed tables will vary</i>	

Specifications subject to change without notice

## Adjustable legs

Order Code		Unit weight (nominal)
<b>5</b>	Adjustable legs w/ glides	10 lb [4.5 kg] (per leg)

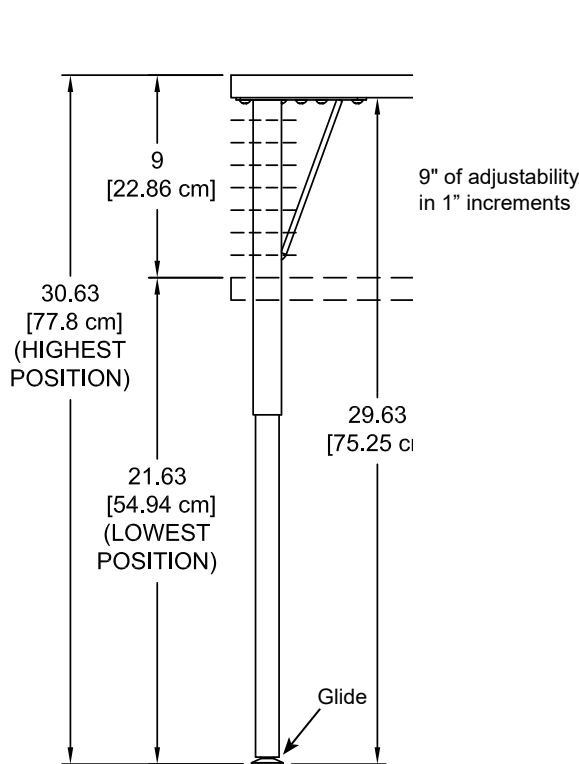

Order Code		Unit weight (nominal)
<b>6</b>	Adjustable legs w/ casters	10 lb [4.5 kg] (per leg)

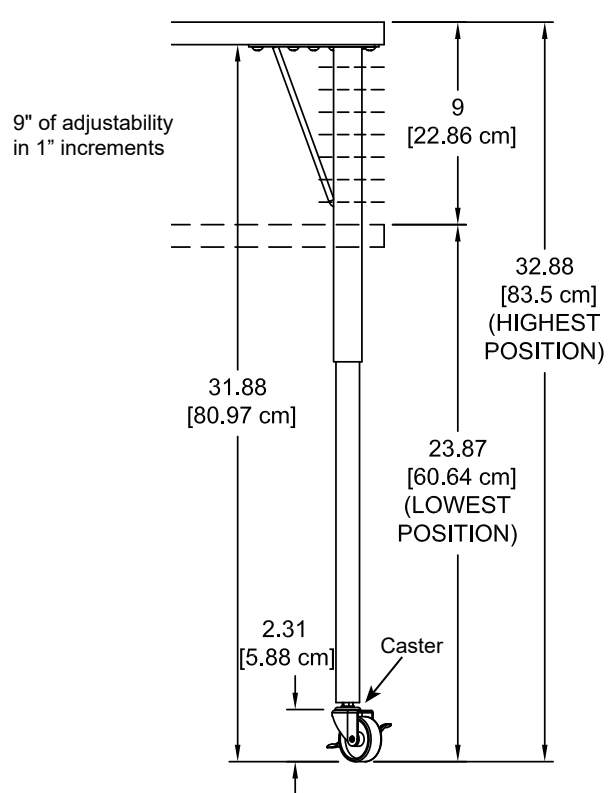

(Shown with optional trays)

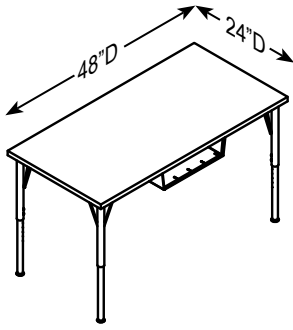

Order Code	Size		Unit weight (nominal)	Shipping weight (nominal)
<b>A</b>	48"W x 24"D	Worksurface	32 lb [15 kg]	33 lb [15 kg]
		(4) Legs	40 lb [18.6 kg]	51.2 lb [23.2 kg]

**Note:** 48"W tables are not wide enough for two people in most situations. Spectrum recommends at least a 60"W table to accommodate 2 people.

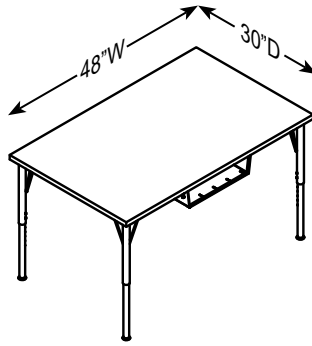

Order Code	Size		Unit weight (nominal)	Shipping weight (nominal)
<b>B</b>	48"W x 30"D	Worksurface	41 lb [19 kg]	50 lb [23 kg]
		(4) Legs	40 lb [18.6 kg]	51.2 lb [23.2 kg]

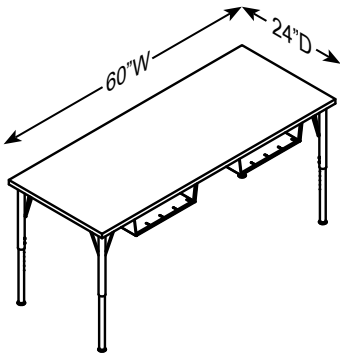

Order Code	Size		Unit weight (nominal)	Shipping weight (nominal)
<b>C</b>	60"W x 24"D	Worksurface	41 lb [19 kg]	50 lb [23 kg]
		(4) Legs	40 lb [18.6 kg]	51.2 lb [23.2 kg]

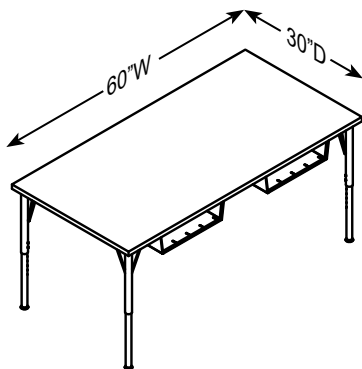

Order Code	Size		Unit weight (nominal)	Shipping weight (nominal)
<b>D</b>	60"W x 30"D	Worksurface	52 lb [24 kg]	62 lb [28 kg]
		(4) Legs	40 lb [18.6 kg]	51.2 lb [23.2 kg]

(Shown with optional trays)

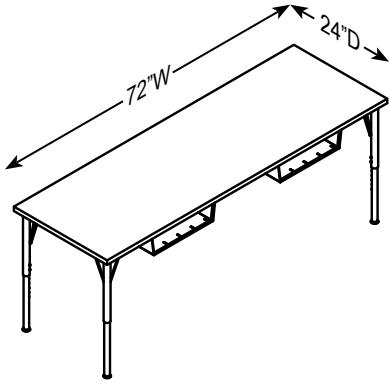

Order Code	Size		Unit weight (nominal)	Shipping weight (nominal)
<b>E</b>	72"W x 24"D	Worksurface	50 lb [23 kg]	59 lb [27 kg]
		(4) Legs	40 lb [18.6 kg]	51.2 lb [23.2 kg]

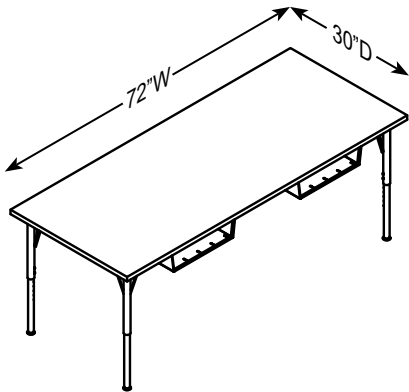

Order Code	Size		Unit weight (nominal)	Shipping weight (nominal)
<b>F</b>	72"W x 30"D	Worksurface	62 lb [28 kg]	75 lb [34 kg]
		(4) Legs	40 lb [18.6 kg]	51.2 lb [23.2 kg]

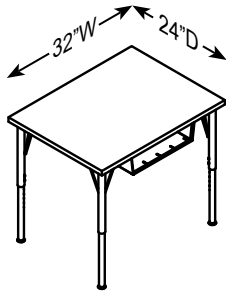

Order Code	Size		Unit weight (nominal)	Shipping weight (nominal)
<b>H</b>	32"W x 24"D	Worksurface	22 lb [10 kg]	31 lb [14 kg]
		(4) Legs	40 lb [18.6 kg]	51.2 lb [23.2 kg]

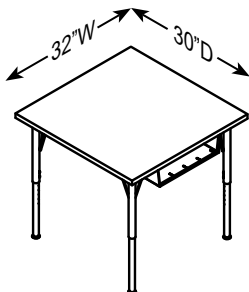

Order Code	Size		Unit weight (nominal)	Shipping weight (nominal)
<b>J</b>	32"W x 30"D	Worksurface	28 lb [12.7 kg]	37 lb [16.8 kg]
		(4) Legs	40 lb [18.6 kg]	51.2 lb [23.2 kg]

Order Code	Size		Unit weight (nominal)	Shipping weight (nominal)
<b>A</b>	48" dia	Worksurface	52 lb [23.6 kg]	61 lb [27.7 kg]
		(4) Legs	40 lb [18.6 kg]	51.2 lb [23.2 kg]

Order Code	Size		Unit weight (nominal)	Shipping weight (nominal)
<b>B</b>	60" dia	Worksurface	81 lb [36.8 kg]	90 lb [40.9 kg]
		(4) Legs	40 lb [18.6 kg]	51.2 lb [23.2 kg]

(Shown with optional trays)

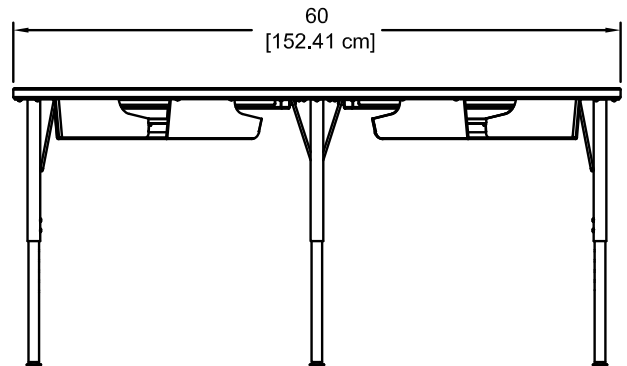
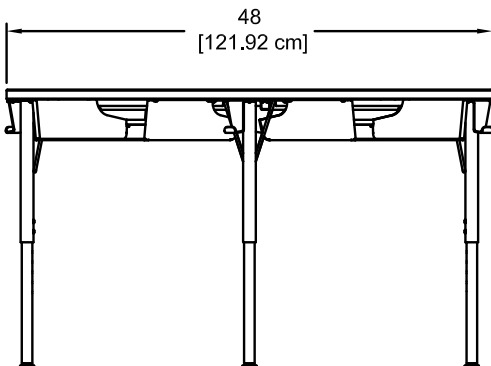
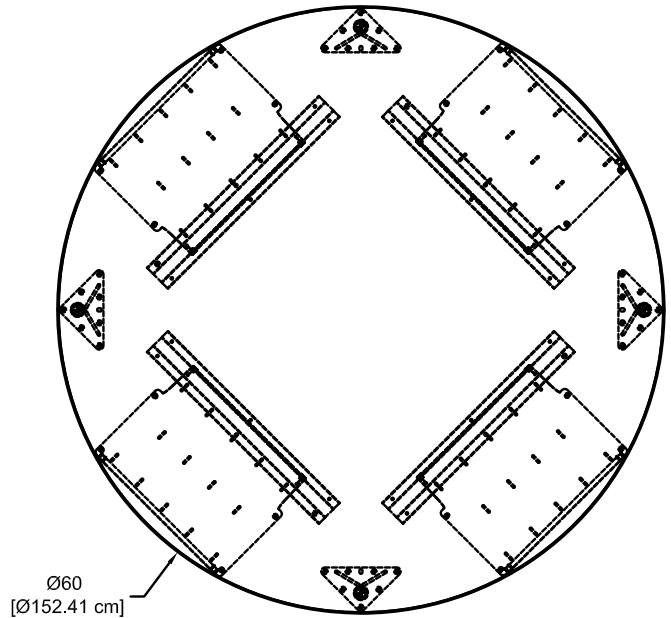
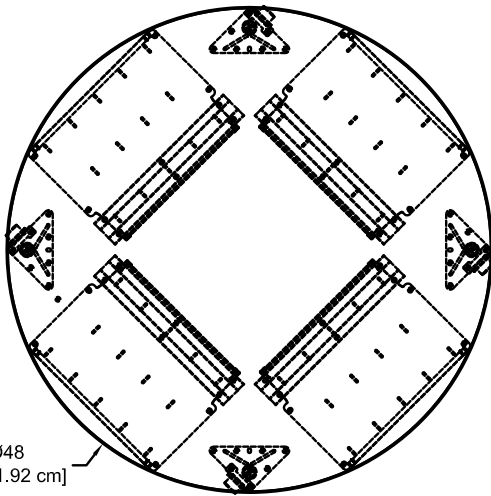
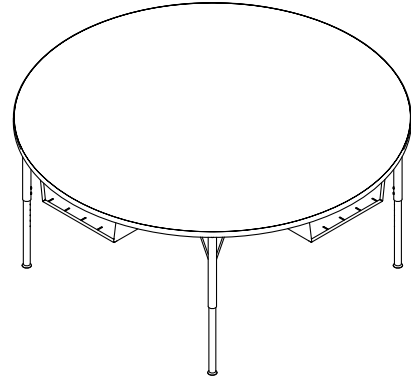
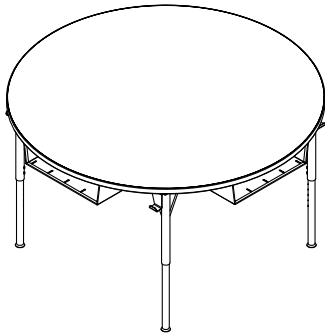

37322 - Half-Round Tables

Order Code	Size		Unit weight (nominal)	Shipping weight (nominal)
<b>A</b>	48"W x 24"D	Worksurface	26 lb [11.8 kg]	35 lb [15.9 kg]
		(3) Legs	30 lb [13.6 kg]	38.4 lb [17.4 kg]

Order Code	Size		Unit weight (nominal)	Shipping weight (nominal)
<b>D</b>	60"W x 30"D	Worksurface	40 lb [18.6 kg]	49 lb [22.2 kg]
		(3) Legs	30 lb [13.6 kg]	38.4 lb [17.4 kg]

(Shown with optional trays)

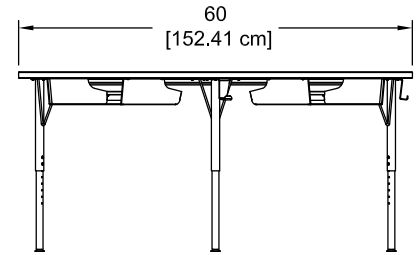
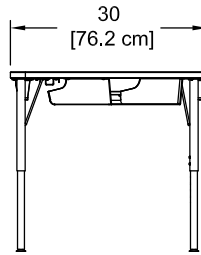
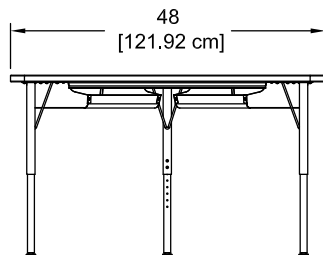
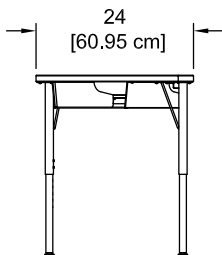
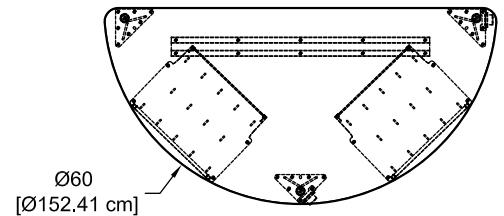
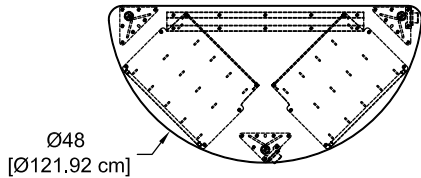
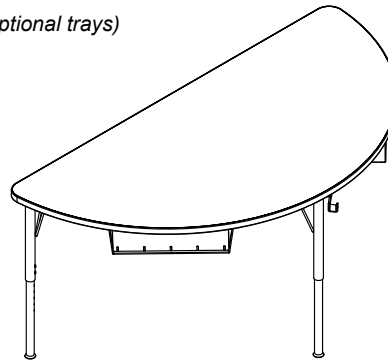
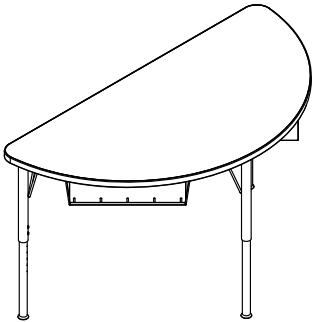

Note: Extra legs may be included with your order.

37368 - Triangular Table

Order Code	Size		Unit weight (nominal)	Shipping weight (nominal)
<b>M</b>	43"W x 23.5"D	Worksurface	20 lb [9.1 kg]	29 lb [13.2 kg]
		(3) Legs	30 lb [13.6 kg]	38.4 lb [17.4 kg]

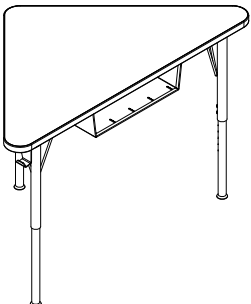
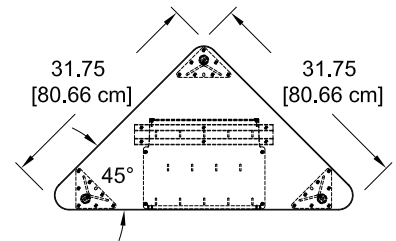

(Shown with optional trays)

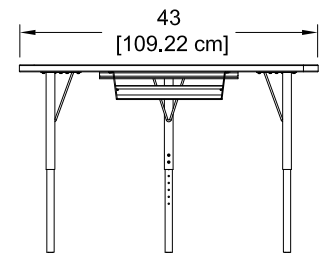
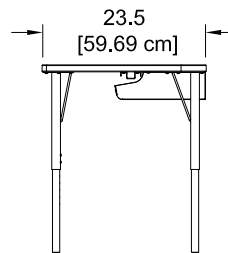

- Available with glides only
- Triangular table is not ADA-compliant

Note: Extra legs may be included with your order.

Order Code	Size		Unit weight (nominal)	Shipping weight (nominal)
<b>K</b>	48"W x 20.8"D	Worksurface	22 lb [11.8 kg]	31 lb [15.9 kg]
		(4) Legs	40 lb [18.6 kg]	51.2 lb [23.2 kg]

Order Code	Size		Unit weight (nominal)	Shipping weight (nominal)
<b>L</b>	60"W x 26"D	Worksurface	34 lb [15.4 kg]	43 lb [19.5 kg]
		(4) Legs	40 lb [18.6 kg]	51.2 lb [23.2 kg]

(Shown with optional tray)

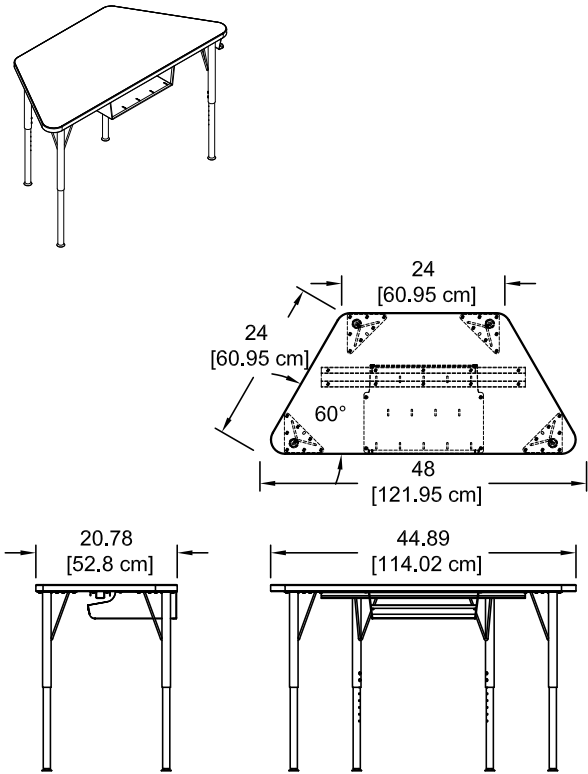

Grouping of 6

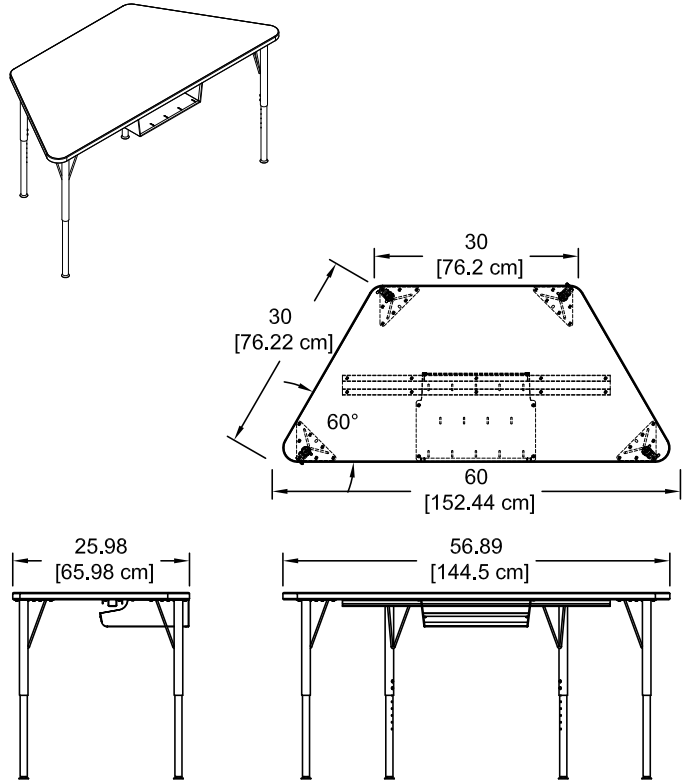
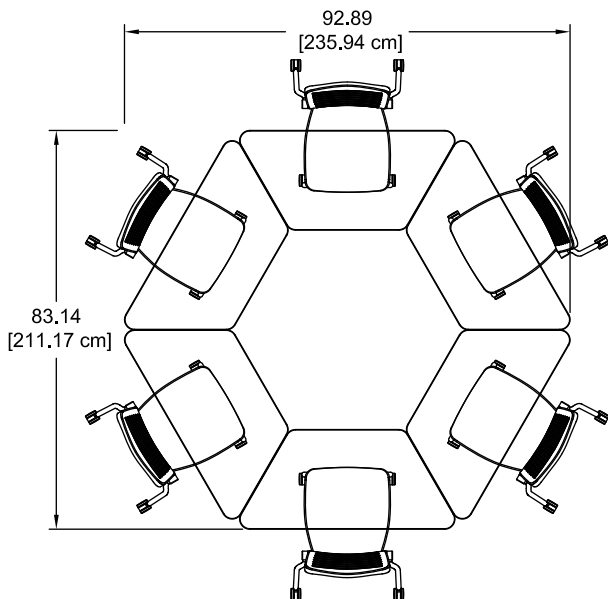

Grouping of 6

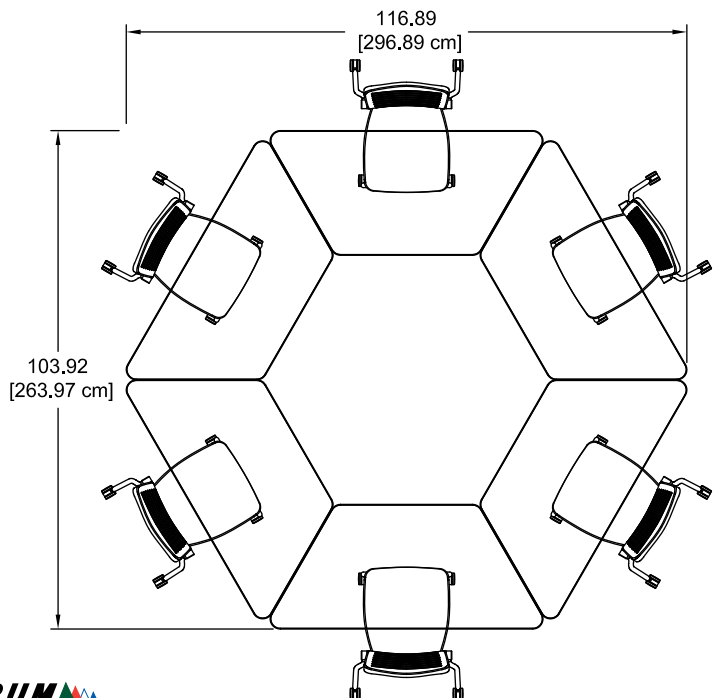

## Accessories

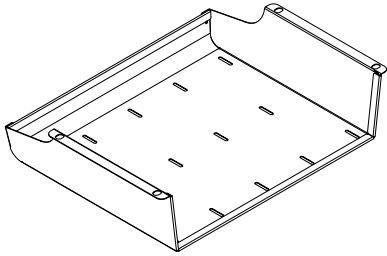

### Tray - 37369

- Provides storage under worksurface for supplies
- 15.15"W x 12.625"D x 4"H
- Black powdercoat
- 20ga steel
- Each tray installs with (4) included screws

Note: When tray is installed, the knee clearance height of the table will no longer be ADA-compliant

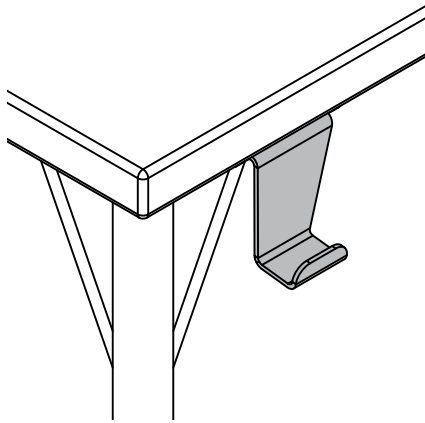

### Backpack Hanger Bracket - 37370

- Includes (one) bracket
- Black powdercoat
- 12 ga steel
- Each hanger bracket installs with (2) included screws
- Each Aspire leg can support up to two brackets

See [spectrumfurniture.com](http://spectrumfurniture.com) for the latest accessories and detailed warranty information.



## Warranty

### We will make it right for you!

Thanks for choosing Spectrum! Spectrum is committed to provide complete customer satisfaction. Each of our products is manufactured from the best materials available and each product is stringently monitored throughout the production process through our P.A.C.E. program (Product Assurance to meet Customer Expectations).

We expressly warrant that Spectrum products will be of good quality and workmanship and free from defect for the period set out in the warranty from the date of delivery.

**For a listing of all product specific warranty terms please visit our website at:**

<https://www.spectrumfurniture.com/en/resources/purchasing-terms-warranty>

**1-800-235-1262**

Toll-free HELPLINE

**[spectrum@spectrumfurniture.com](mailto:spectrum@spectrumfurniture.com)**



Pending



Spectrum Industries is Certified ISO 9001:2015