

Flex Active Flip Table™

37319

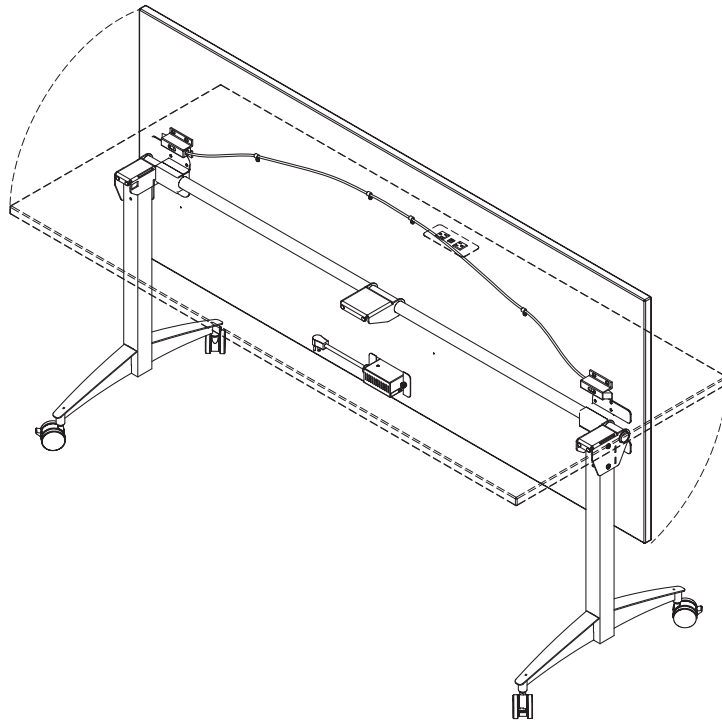

Important	Important	Importante
<p>Before using this product:</p> <ul style="list-style-type: none"> • Read this manual • Comply with all safety and operating instructions • Ensure all parts and correct quantities are included <p>Any parts damaged during shipment must be reported within 5 days of receipt. To report information regarding missing parts or damage, to purchase parts or accessories, or if you have any questions, please contact us.</p> <p>Thank you for purchasing Spectrum products!</p>	<p>Avant d'utiliser ce produit:</p> <ul style="list-style-type: none"> • Veuillez à lire ce guide • Respectez les consignes de sécurité et d'utilisation • Vérifiez que vous disposez de toutes les pièces nécessaires à l'installation <p>Les pièces endommagées pendant le transport doivent faire l'objet d'un rapport dans les 5 jours de leur réception. Veuillez prendre contact avec nous si des pièces manquent ou sont abîmées, si vous avez des questions, ou encore pour acheter des pièces ou des accessoires.</p> <p>Merci pour votre achat d'un produit Spectrum!</p>	<p>Antes de utilizar este producto:</p> <ul style="list-style-type: none"> • Lea este manual • Cumpla con todas las instrucciones de prevención de accidentes y operativas • Revise que todas las partes y las cantidades correctas estén incluidas <p>Si alguna parte se dañó durante el embarque, deberá reportarla en un lapso de 5 días a partir de la recepción. Para reportar cualquier información sobre partes faltantes o dañadas, para adquirirlas o comprar accesorios, o bien, si tiene alguna duda, póngase en contacto con nosotros.</p> <p>¡Gracias por adquirir productos Spectrum!</p>



www.spectrumfurniture.com

Owner's Manual Le manuel du propriétaire El manual del propietario	Specs Spécifications Especificaciones	Video Vidéo Vídeo
--	---	-------------------------

800-235-1262

Components

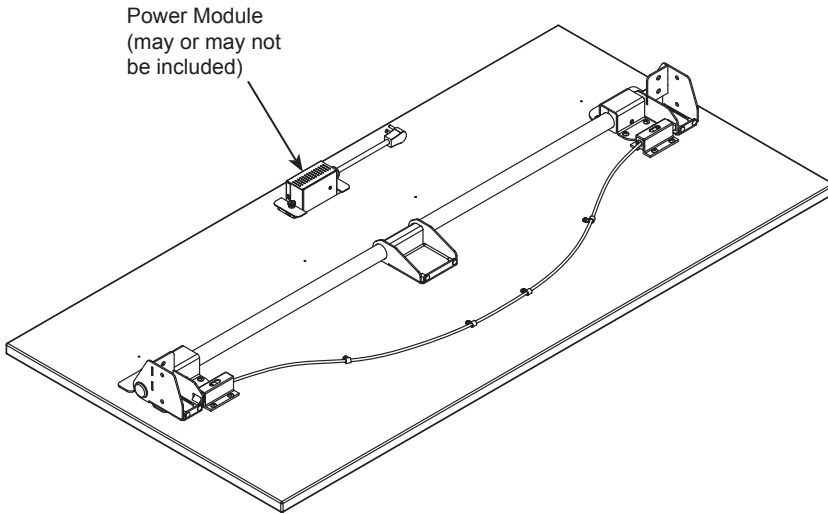

Power Module
(may or may not
be included)

(1) Worksurface assembly

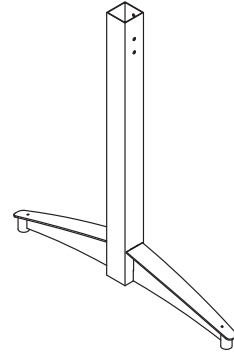

(2) 0141220
Flex Active Flip leg

Hardware

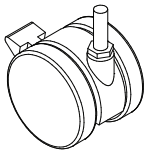

(4) 0105662
Stem Caster 60mm
5/16-18 x 1"

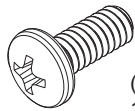

(8) 026064
1/4-20 x 5/8" PHMS

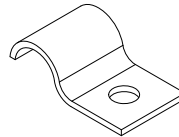

(4) 051070
Cable clip

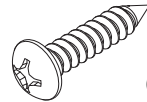

(4) 026073
#8 x 3/4" PHSM



Important Safety and Care Instructions



- Read this owner's manual before assembly or operation.
- Do not allow children to move the table.
- For indoor use only. Do not install or store the table where it will be exposed to moisture.
- Do not block the ventilation openings.
- Do not allow anyone to sit, stand, or climb on the table.
- Use a damp, soft-cloth, or sponge, with mild soap or detergent solution to clean dirty surfaces. Do not use harsh solvents or abrasives.
- This table is intended for institutional use. It does not have any user-serviceable parts or user-maintenance requirements. If servicing is necessary, please contact Spectrum Industries for assistance.

Warning - Relocating audio and/or video equipment to furniture not specifically designed to support audio and/or video equipment may result in death or serious injury due to the furnishing collapsing or over turning onto a child.

Warning - Death or serious injury may occur when children climb on audio and/or video equipment furniture. A remote control or toys placed on the furnishing may encourage a child to climb on the furnishing and as a result the furnishing may tip over on to the child.

General Electrical Safety:

- Keep power switches in the OFF position before plugging or unplugging from the wall outlet.
- Be sure total device / equipment load does not exceed 12-amps.
- Do not plug power cords into an extension cord.
- Inspect power cords for damage before each use. Do not use cords that are damaged.
- Unplug power cord from electrical outlet by gripping the cord-do not unplug by pulling only on the cord.
- Do not step on, drive over, drag, or place objects on power cords.
- For added safety, plug into a grounded outlet controlled by a GFI (Ground Fault Interrupter) circuit breaker.
- Damaged electrical components can create significant hazards to users and is not covered by the warranty. Repairs should always be performed by a qualified electrician.
- Electrical devices are not toys. Children are often unaware of the hazards associated with electrical devices. This table must always be used by adults or with adult supervision.

Assembly

1 Attach legs to worksurface assembly

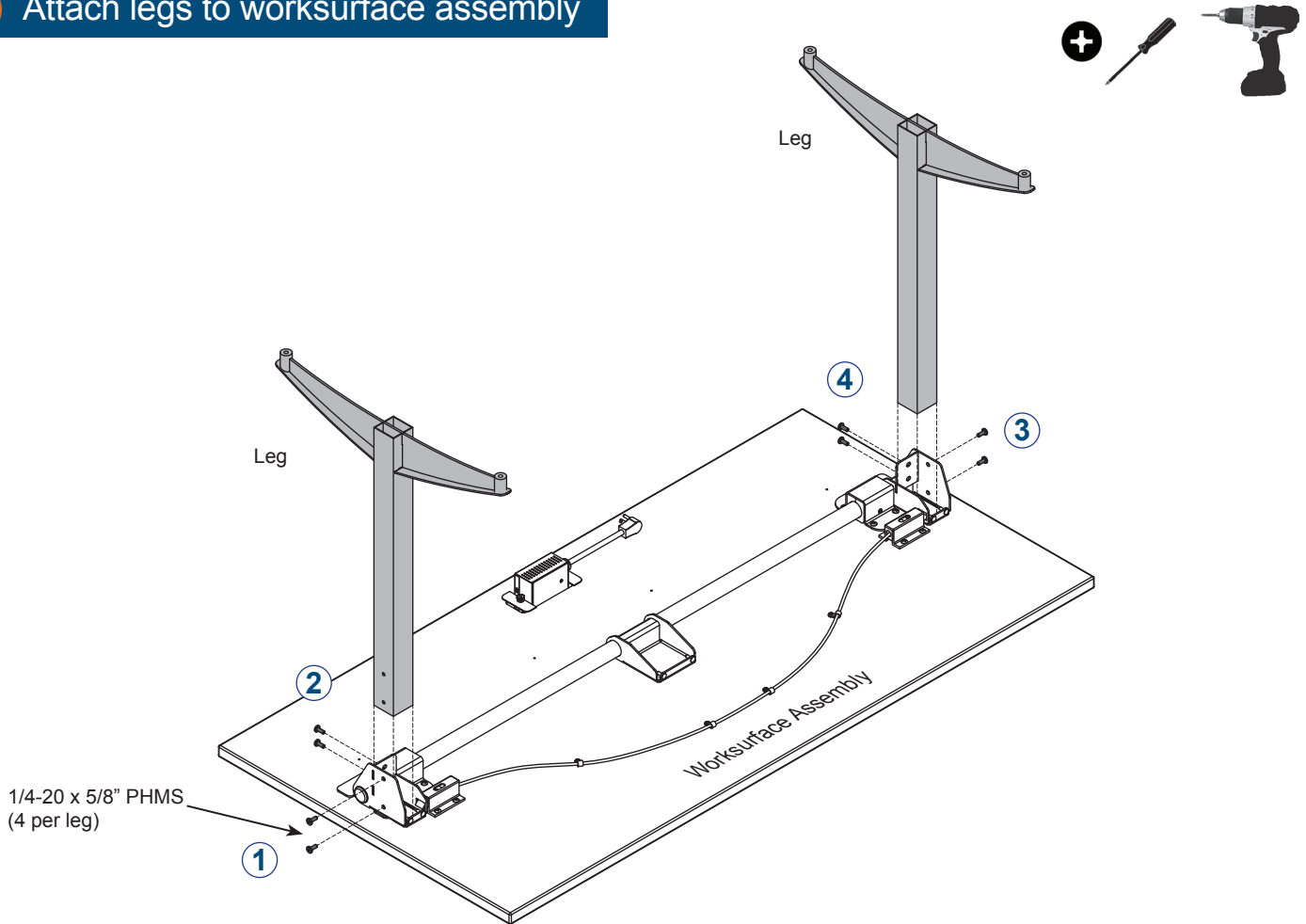

2 Install casters

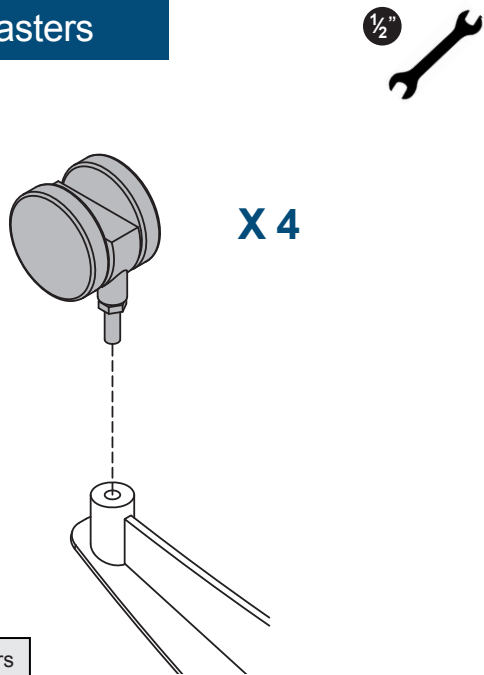

Note: Be sure casters are tightened securely.

3 Secure power cords - (if equipped)

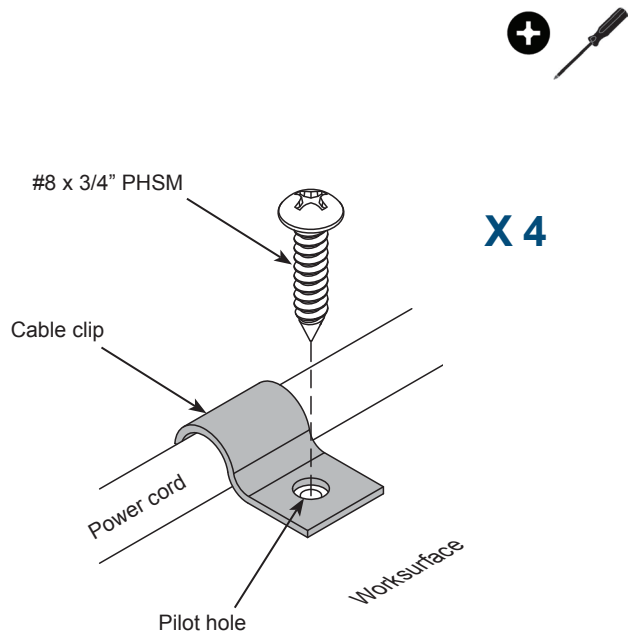

4 Place upright

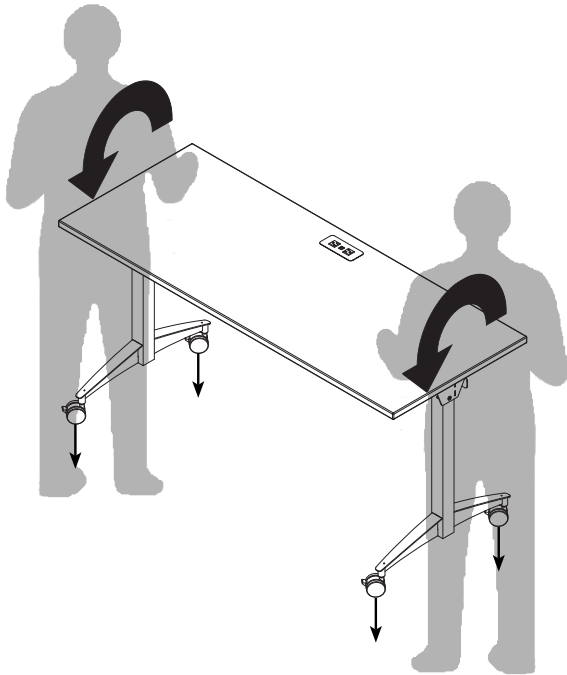

Note: If any casters are not contacting the floor, loosen the 1/4-20 x 5/8" PHM leg screws installed in step 1. After making sure all casters contact the floor, retighten the screws.

5 Flipping worksurface

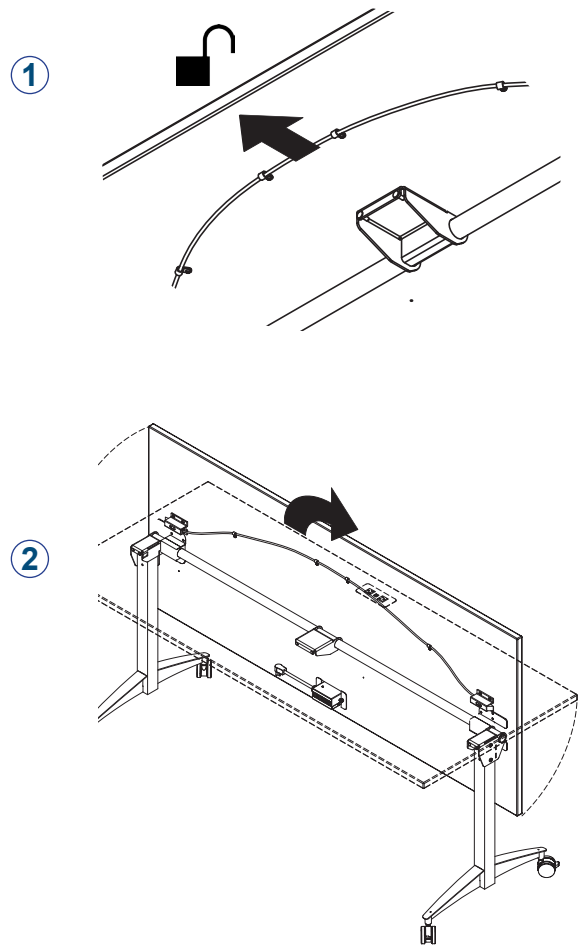

6 Casters

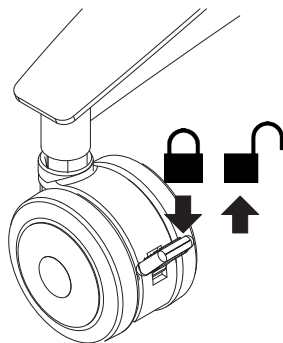

7 Nesting

