

Technical Specifications

37326

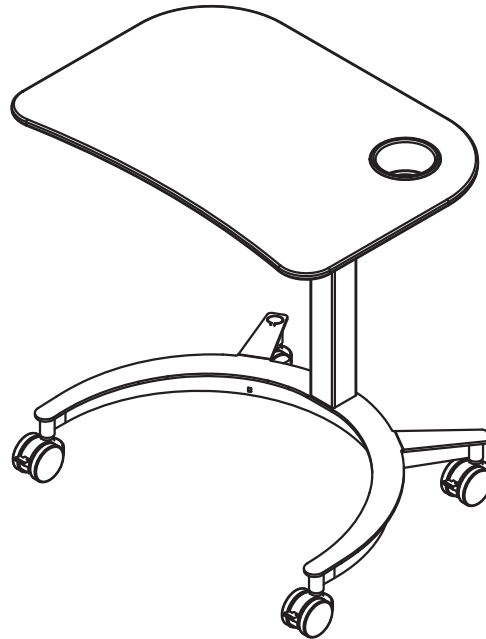

The Pivot Jr Workstation™ allows you to take your work with you. Highly mobile, height-adjustable, and sized perfectly for today's continuously changing classrooms.

Features and Benefits

- Manual adjustable-height worksurface from 27"-42"H
- Scratch and impact-resistant high-pressure laminate worksurface (also available in chalk white dry erase laminate)
- Durable powder coated steel frame provides a long-lasting finish
- Worksurface vinyl edging protects walls and furniture
- Worksurface cup holder provides secure location for a beverage
- Available with 60mm twin-wheel casters to provide easy mobility (4 locking) or glides for stationary use
- Included hanger provides a place for a backpack or purse
- Optional Glide Kit provides stationary use for units initially ordered with casters
- Meets or exceeds applicable ANSI-BIFMA test standards
- Workstation ships KD (knocked-down) and requires assembly
- Warranted to be free of all defects in materials and workmanship for 10 years
- Designed and assembled in Chippewa Falls, WI, USA

Construction

- The worksurface is constructed from 3/4" thick NAUF (no added urea formaldehyde) composite board with .030" high-pressure laminate on one face, and a balancing phenolic backer on the opposing face
- Base components consist of 7-gauge steel
- Worksurface edges are covered with 3mm vinyl
- All metal components are finished with a scratch-resistant powder coat epoxy
- Each PIVOT Jr Workstation ships KD (knocked-down) and requires assembly

Specifications

Worksurface height adjustability (floor to top of worksurface)	42"H [106.7 cm] (fully-raised) 27"H [68.6 cm] (fully-lowered)
Max worksurface capacity	20 lb [9.1 kg]
Twin-wheel casters	<ul style="list-style-type: none"> • Diameter: 2.36" [60 mm] • Locking: all 4 casters • Weight capacity: 90 lb [40.9 kg] each
Certifications / Compliance	<ul style="list-style-type: none"> • SCS Indoor Advantage Certified • Meets or exceeds applicable ANSI-BIFMA test standards
Unit weight (nominal)	27 lb [12.3 kg] with casters 26 lb [11.8 kg] with glides
Shipping weight (nominal)	33 lb [15 kg] with casters 32 lb [14.5 kg] with glides

Specifications subject to change without notice

Color Options

Worksurface laminate and metal chassis available in Spectrum Expressions colors.

See spectrumfurniture.com for complete color information.

Ordering Instructions

Spectrum has designed this workstation to receive the useful options shown here. To ensure your lectern and options are ordered correctly please call 1-800-235-1262.

ORDER CODE 02 = Glides

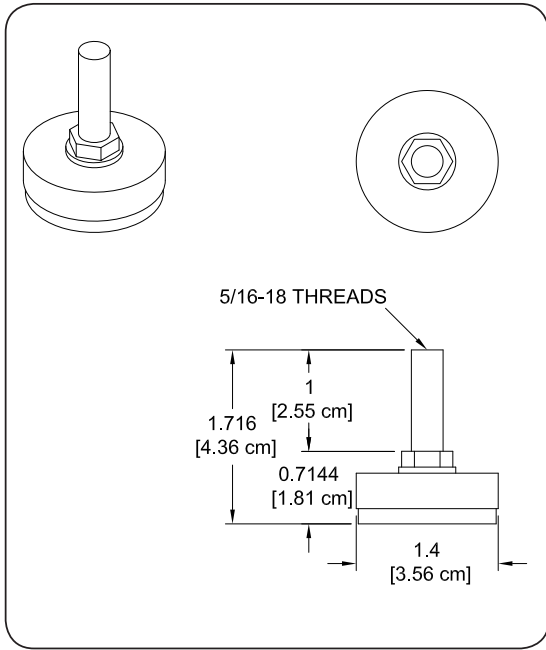

Note: Glides will lower the overall height of the unit about 1" compared with the twin-wheel casters.

ORDER CODE TW = Twin-Wheel Casters

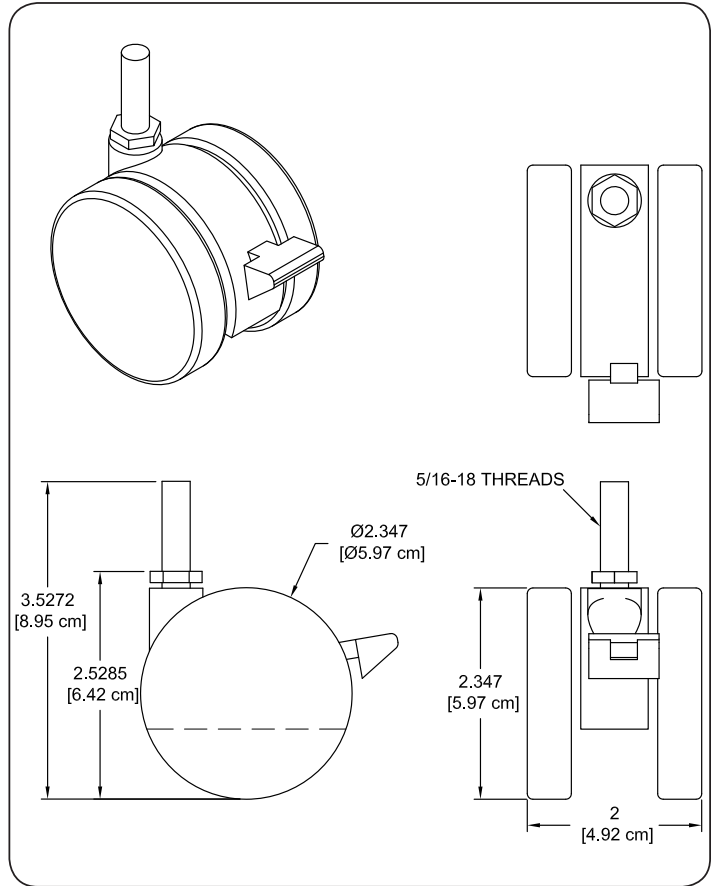

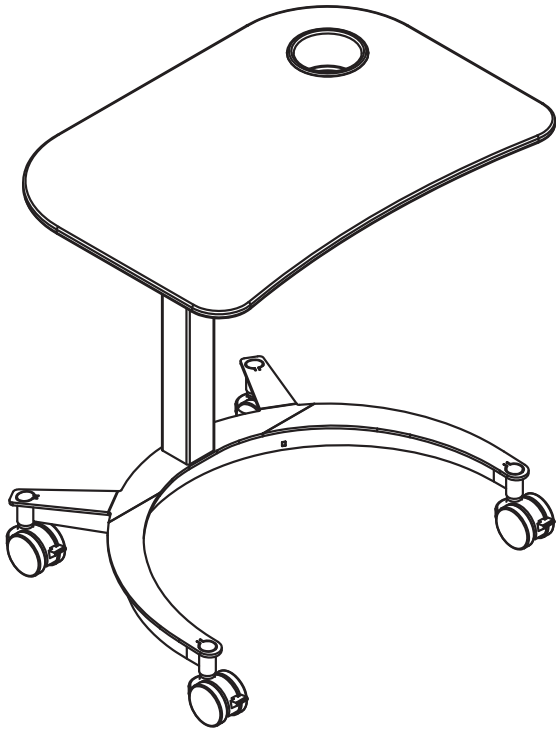

Pivot Jr Workstation

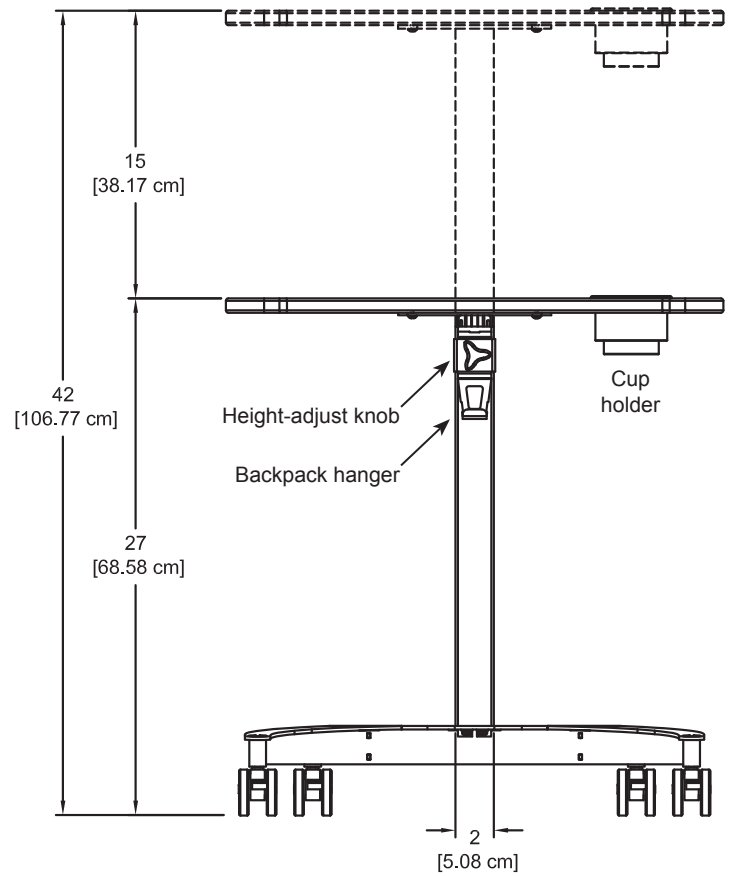
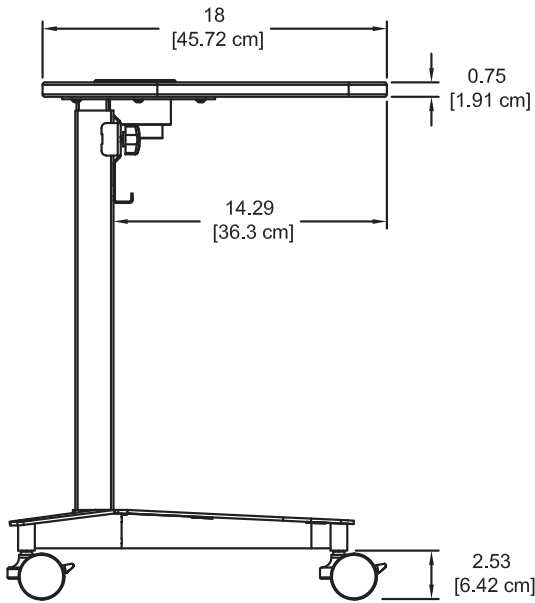
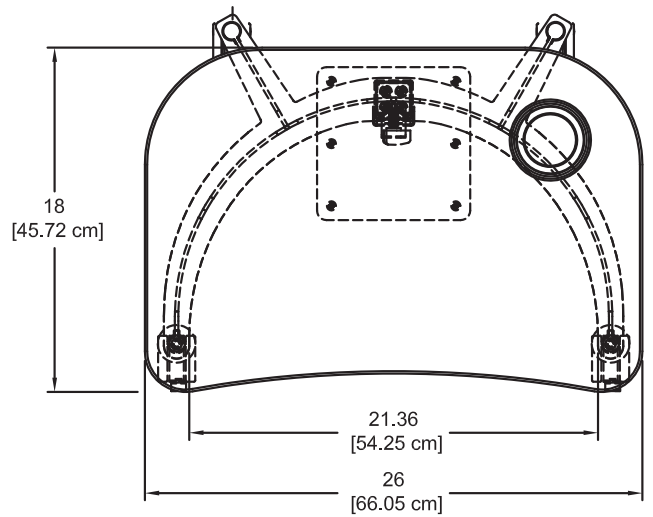

Accessories

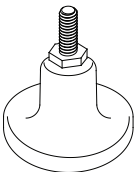

Glide Kit - 98513

- Set of 4
- 5/16-18 thread
- 1" long
- Shipping weight: .5 lb [.23 kg]

See spectrumfurniture.com for the latest accessories and detailed warranty information.

Warranty

We will make it right for you!

Spectrum is committed to provide complete customer satisfaction. Each of our products is manufactured from the best materials available and each product is stringently monitored throughout the production process through our Quality Management System.

We expressly warrant that Spectrum products will be of good quality and workmanship and free from defect for the period set out in the warranty table below from the date of delivery. This warranty shall not apply to defects or damage resulting from normal wear and tear, misuse, or unintended use, failure to follow instructions related to the product's installation or intended use, abuse, neglect, improper care, modification or repair not authorized by Spectrum, or any other cause outside the control of Spectrum. Spectrum will, at its sole option, either repair or replace the defective product.

This warranty is exclusive; no other warranty, written or oral, is expressed or implied. This warranty is given by Spectrum to Buyer or Buyer third party end user and to no other person or legal entity. No Spectrum dealer, distributor, partner, reseller, agent or employee is authorized to make any modification or addition to this warranty.

NOTWITHSTANDING ANYTHING TO THE CONTRARY, SPECTRUM WILL NOT UNDER ANY CIRCUMSTANCES BE LIABLE FOR INDIRECT OR LIQUIDATED DAMAGES, INCLUDING CONSEQUENTIAL, INCIDENTAL AND SPECIAL DAMAGES. IN NO EVENT SHALL SPECTRUM'S LIABILITY, WHETHER UNDER CONTRACT OR WARRANTY, IN TORT OR OTHERWISE, EXCEED THE PURCHASE PRICE RECEIVED BY SPECTRUM FOR THE PRODUCT AT ISSUE AND "RECALL ACTION" EXPENSES. SPECTRUM SHALL NOT BE SUBJECT TO ANY OTHER OBLIGATIONS OR LIABILITIES, WHETHER ARISING OUT OF BREACH OF CONTRACT, WARRANTY, TORT (INCLUDING NEGLIGENCE AND STRICT LIABILITY) OR OTHER THEORIES OF LAW, WITH RESPECT TO PRODUCTS SOLD OR SERVICES RENDERED BY SPECTRUM, OR ANY UNDERTAKINGS, ACTS OR OMISSIONS RELATING THERETO.

Our Customer Service Department is ready to provide immediate attention to any questions, comments or concerns. They are available to answer your calls Monday through Friday from 7 am to 5 pm CST. In addition your product comments or concerns are welcome via e-mail at: spectrum@spectrumfurniture.com.

Warranty Table

Item	Warranty Period
Desk, table, cart and lectern chassis	10 Years
Electrical	2 Years
Flat panel monitor arms / gas spring / general parts	2 Years
Adjustable crank / electric legs and accessories	2 Years
Flat panel desk gas spring cylinders	2 Years
Height adjustable columns, lifts & accessories	2 Years
Casters & wheels	2 Years
Keyboard, mouse, trays	2 Years
Locks & keys	2 Years
Tubs, totes and other accessories	1 Year
Chairs	7 Years
Structural components, including gas cylinders, wood, metal and plastic parts (i.e., chair frames, bases and control handles)	
Consumable items (i.e., casters, glides, etc.)	
In-stock upholstery	5 Years
Customer supplied material	No Warranty

