

Pivot Jr Workstation™

37326



Important	Important	Importante
<p>Before using this product:</p> <ul style="list-style-type: none"> • Read this manual • Comply with all safety and operating instructions • Ensure all parts and correct quantities are included <p>Any parts damaged during shipment must be reported within 5 days of receipt. To report information regarding missing parts or damage, to purchase parts or accessories, or if you have any questions, please contact us.</p> <p>Thank you for purchasing Spectrum products!</p>	<p>Avant d'utiliser ce produit:</p> <ul style="list-style-type: none"> • Veuillez à lire ce guide • Respectez les consignes de sécurité et d'utilisation • Vérifiez que vous disposez de toutes les pièces nécessaires à l'installation <p>Les pièces endommagées pendant le transport doivent faire l'objet d'un rapport dans les 5 jours de leur réception. Veuillez prendre contact avec nous si des pièces manquent ou sont abîmées, si vous avez des questions, ou encore pour acheter des pièces ou des accessoires.</p> <p>Merci pour votre achat d'un produit Spectrum!</p>	<p>Antes de utilizar este producto:</p> <ul style="list-style-type: none"> • Lea este manual • Cumpla con todas las instrucciones de prevención de accidentes y operativas • Revise que todas las partes y las cantidades correctas estén incluidas <p>Si alguna parte se dañó durante el embarque, deberá reportarla en un lapso de 5 días a partir de la recepción. Para reportar cualquier información sobre partes faltantes o dañadas, para adquirirlas o comprar accesorios, o bien, si tiene alguna duda, póngase en contacto con nosotros.</p> <p>¡Gracias por adquirir productos Spectrum!</p>



www.spectrumfurniture.com

Owner's Manual Le manuel du propriétaire El manual del propietario	Specs Spécifications Especificaciones	Video Vidéo Vídeo
--	---	-------------------------



800-235-1262

Components

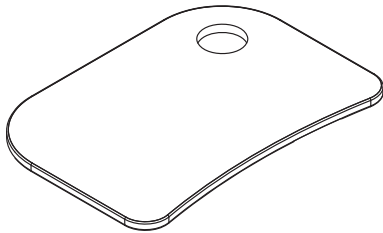

(1) Worksurface

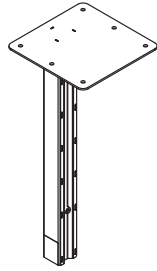

(1) 0139448
Upper column



(1) 0139449
Lower column

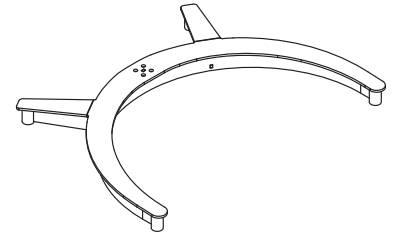

(1) 0137955
Base

Hardware



(1) 0138967
Cup holder

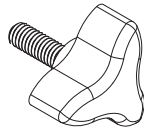

(1) 038011
5/16-18 Height-
adjustment knob



(4) 026059
1/4" Flat washer

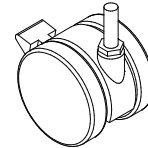

(4) 0105662
60mm 5/16-18
Stem caster

or

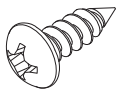

(6) 038064
#14 x 3/4" PHSM

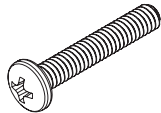

(4) 026547
1/4-20 x 1-1/2"
PHMS



(4) 020728
1/4" Split lock washer

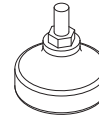

(4) 107763
5/16-18 Glides



Important Safety and Care Instructions



- Read this owner's manual before assembly or operation.
- Do not allow children to operate.
- For indoor use only. Do not install or store where it will be exposed to moisture.
- Do not block the ventilation openings.
- Do not allow anyone to sit, stand, or climb on the unit.
- Use a damp, soft-cloth, or sponge, with mild soap or detergent solution to clean dirty surfaces. Do not use harsh solvents or abrasives.
- This unit is intended for institutional use. It does not have any user-serviceable parts or user-maintenance requirements. If servicing is necessary, please contact Spectrum Industries for assistance.

Warning - Relocating audio and/or video equipment to furniture not specifically designed to support audio and/or video equipment may result in death or serious injury due to the furnishing collapsing or over turning onto a child.

Warning - Death or serious injury may occur when children climb on audio and/or video equipment furniture. A remote control or toys placed on the furnishing may encourage a child to climb on the furnishing and as a result the furnishing may tip over on to the child.

1 Attach upper column to worksurface 

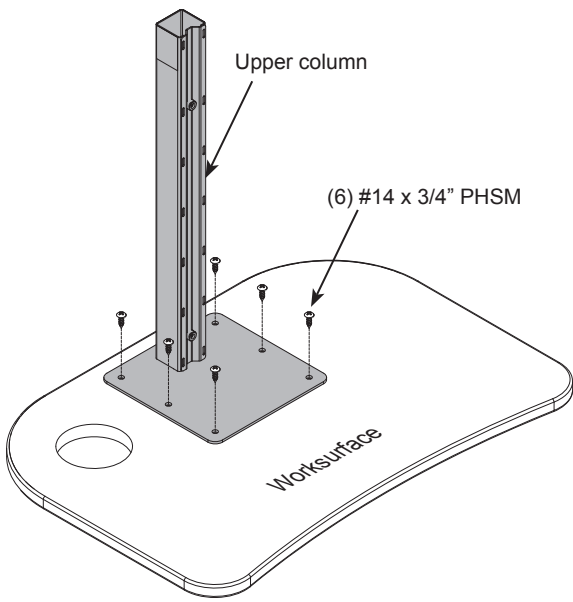

2 Attach base to lower column 

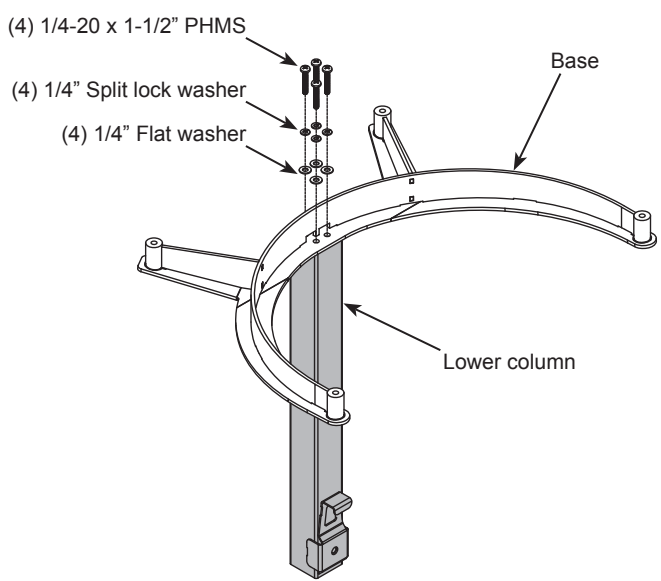

3 Attach upper and lower assemblies

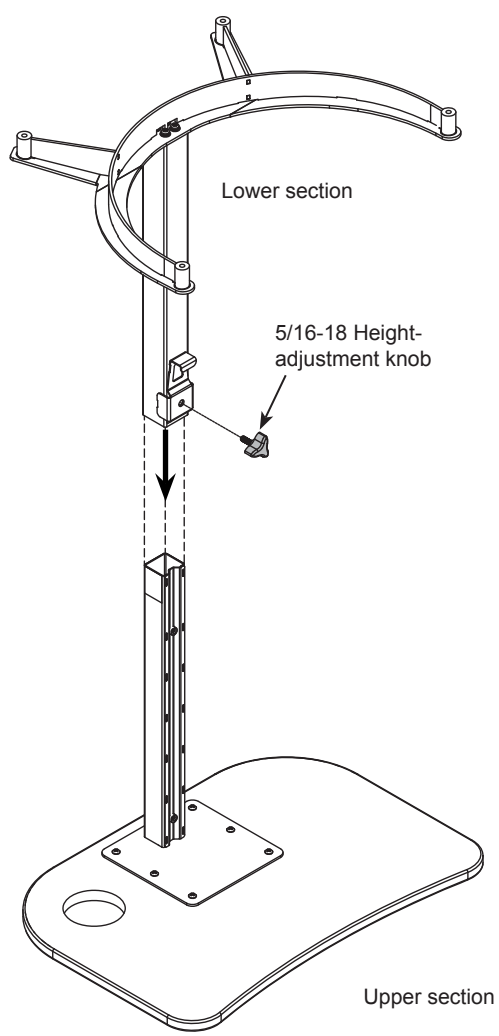

4 Install casters or glides 

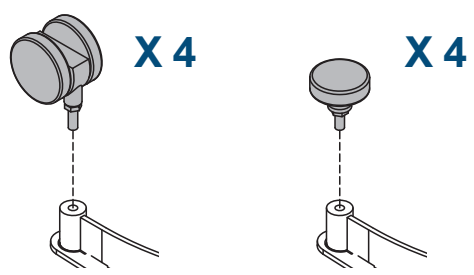

5 Flip upright 

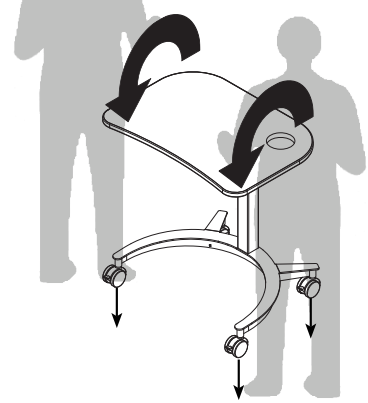

6 Install cup holder 

