

Assembly Instructions:

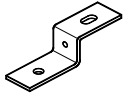

(4) 0102049
1/8" Steel 'Z' Bracket

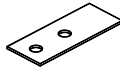

(2) 036207
Flip-Top Support
Bracket



(10) 026064
1/4-20 x 5/8" PHMS



(4) 050524
#8 x 3/4" PH TEK
Screw

Tools Required:
Phillips Screwdriver
Electric Drill

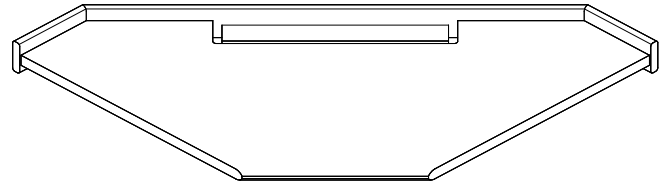

Evolution Corner Connector (24") #38917

Before you begin, please make sure all parts and proper quantities are included. Any parts damaged during shipment must be reported within 15 days of receipt. To report information regarding damages or if you have any questions, please call 1-800-235-1262.

1. Attach Flip-Top Support Brackets and Cord Channel

- Place Corner Connector upside-down onto a non-abrasive surface.
- Attach the two Flip-Top Support Brackets and Cord Channel with 1/4-20 x 5/8" PHM Screws as shown in **Figure 1**.

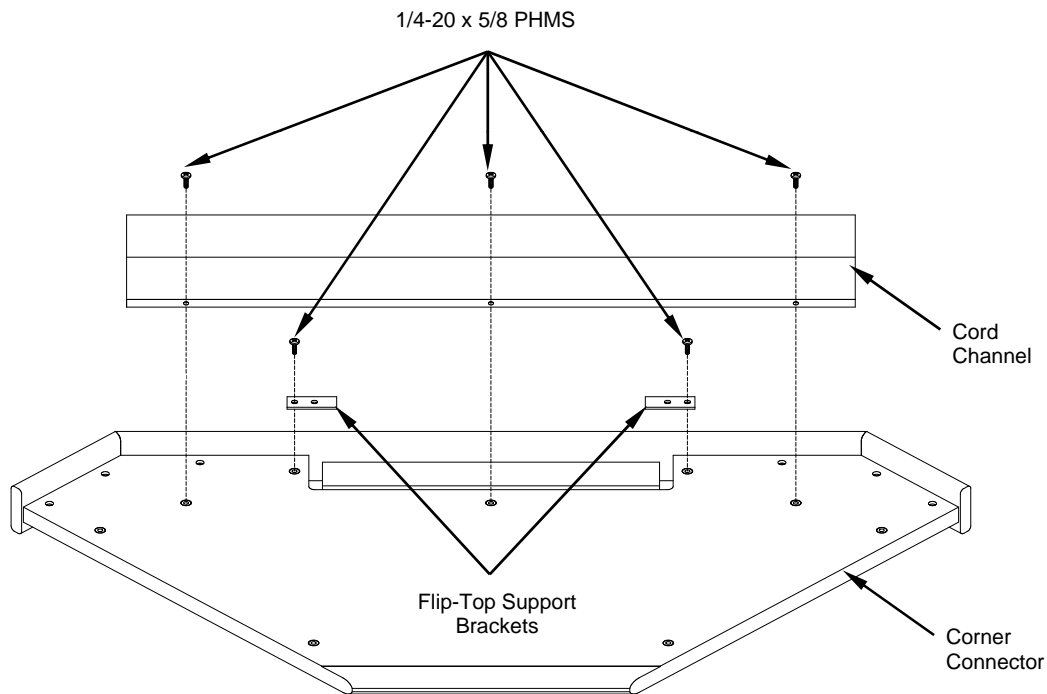
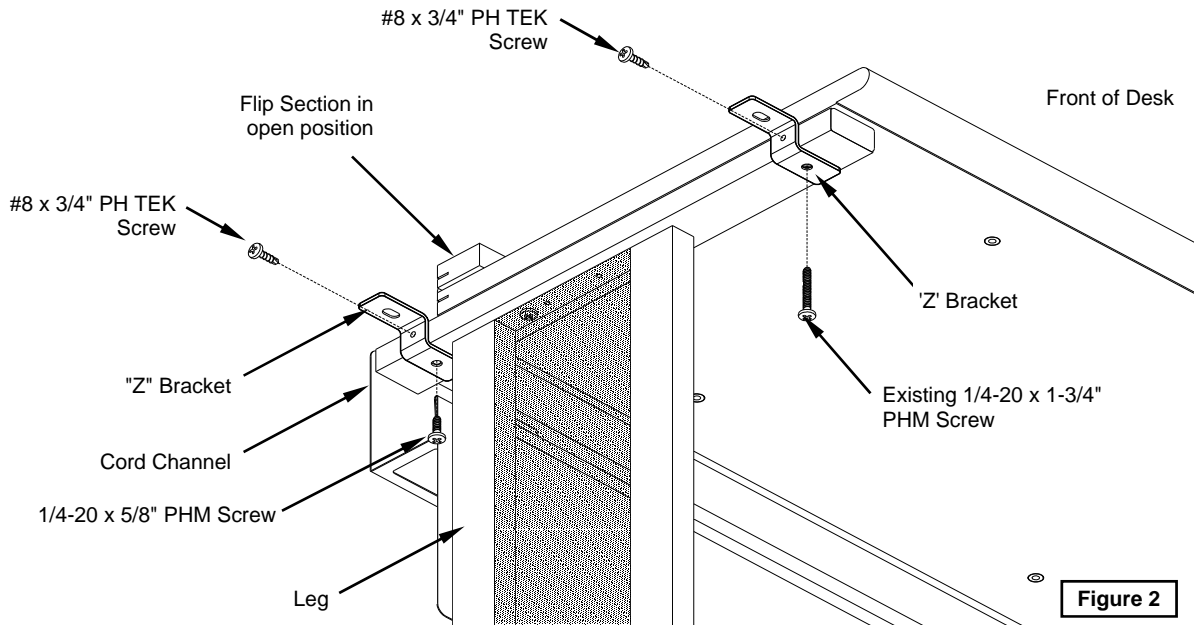

Figure 1

2. Attach Brackets to Desks

- Remove the existing front 1/4-20 x 1-3/4" PHM Screw that attach the Leg to the worksurface.
- Position "Z"-Brackets as shown in **Figure 2**. (The elongated hole in the "Z"-Bracket will attach to the Corner Connector.) Attach the rear "Z"-Bracket to the Leg using a 1/4-20 x 5/8" PHM Screw as shown in **Figure 2**, attach the front 'Z' Bracket with the existing 1/4-20 x 1-3/4" PHM Screw. Tighten completely.
- Install a #8 x 3/4" Tek Screw through each "Z"-Bracket using an electric drill with a phillips head driver. Note: This is a self-drilling screw-no pilot hole is required. If your drill has a torque setting, set it to medium and tighten the screw securely, but be careful not to strip-out the hole while tightening the screw. If possible, setting the drill on high speed may facilitate installation.
- Repeat this procedure for the opposite side of the Corner Connector.



3. Attach Corner Connector to Desks

- Align both desks 90° to each other leaving about 14" between the corners as shown in **Figure 3**.
- Place the Corner Connector onto the 'Z' Brackets and align the mounting holes.
- Attach with (4) 1/4-20 x 5/8" PHM Screws, but do not tighten completely-after the screws are started, alignment of the desks may be necessary.
- After alignment is satisfactory, tighten all screws.

