

Assembly Instructions

⚠ Important ⚠

Before you begin, read and comply with all safety and operating instructions, and ensure all parts and correct quantities are included.

Any parts damaged during shipment must be reported within 5 days of receipt. To report information regarding missing parts or damage, to purchase parts or accessories, or if you have any questions, please contact us.

www.spectrumfurniture.com
800-235-1262, 715-723-6750

Thank you for purchasing Spectrum products!

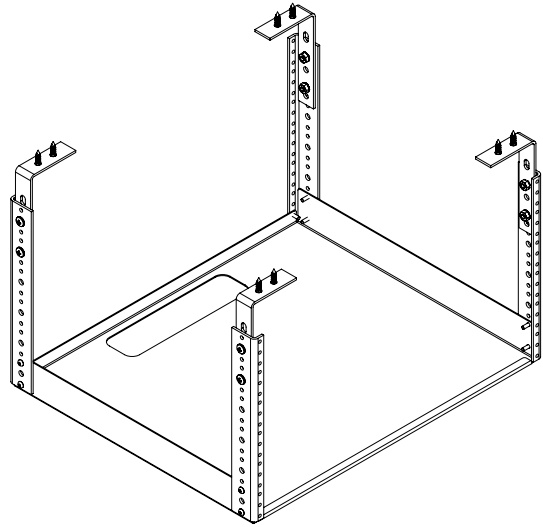

6RU Rack Rail Kit for Pivot Premier 38983

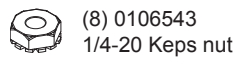
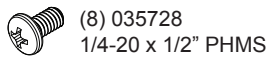
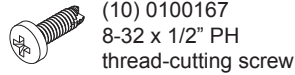
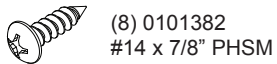
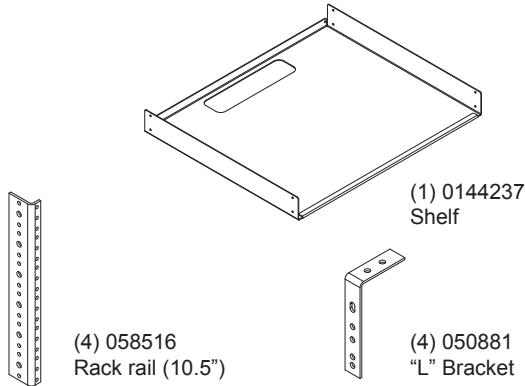

1. Assemble rack cube

1. Attach the rails to the shelf with (10) 8-32 x 1/2" PH thread-cutting screws. Note the orientation of the rails. **Figure 1.**
2. Attach each bracket to a rail as shown with (2) 1/4-20 x 1/2" PHM screws, and (2) 1/4-20 Keps nuts.
3. Tighten all fasteners securely.

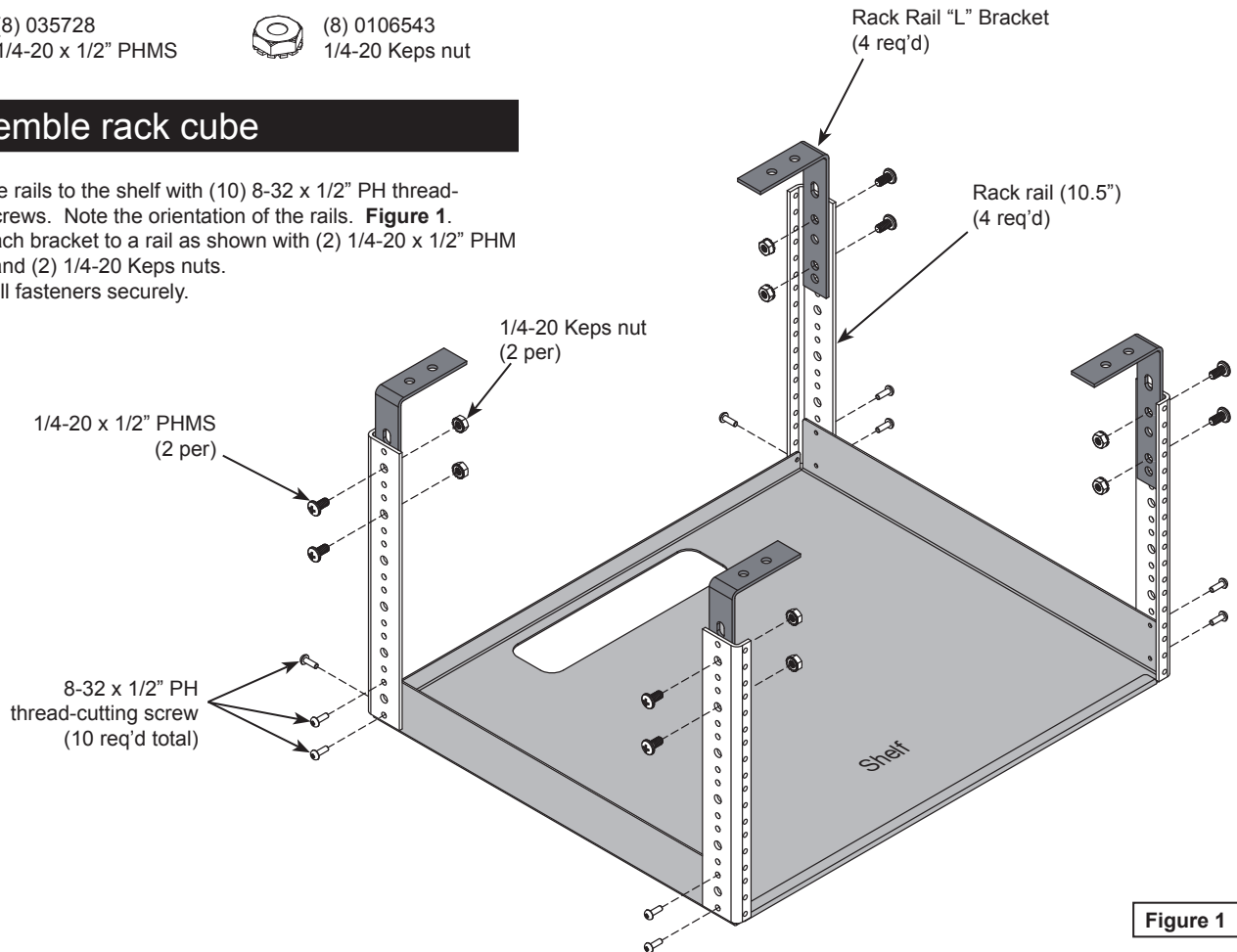
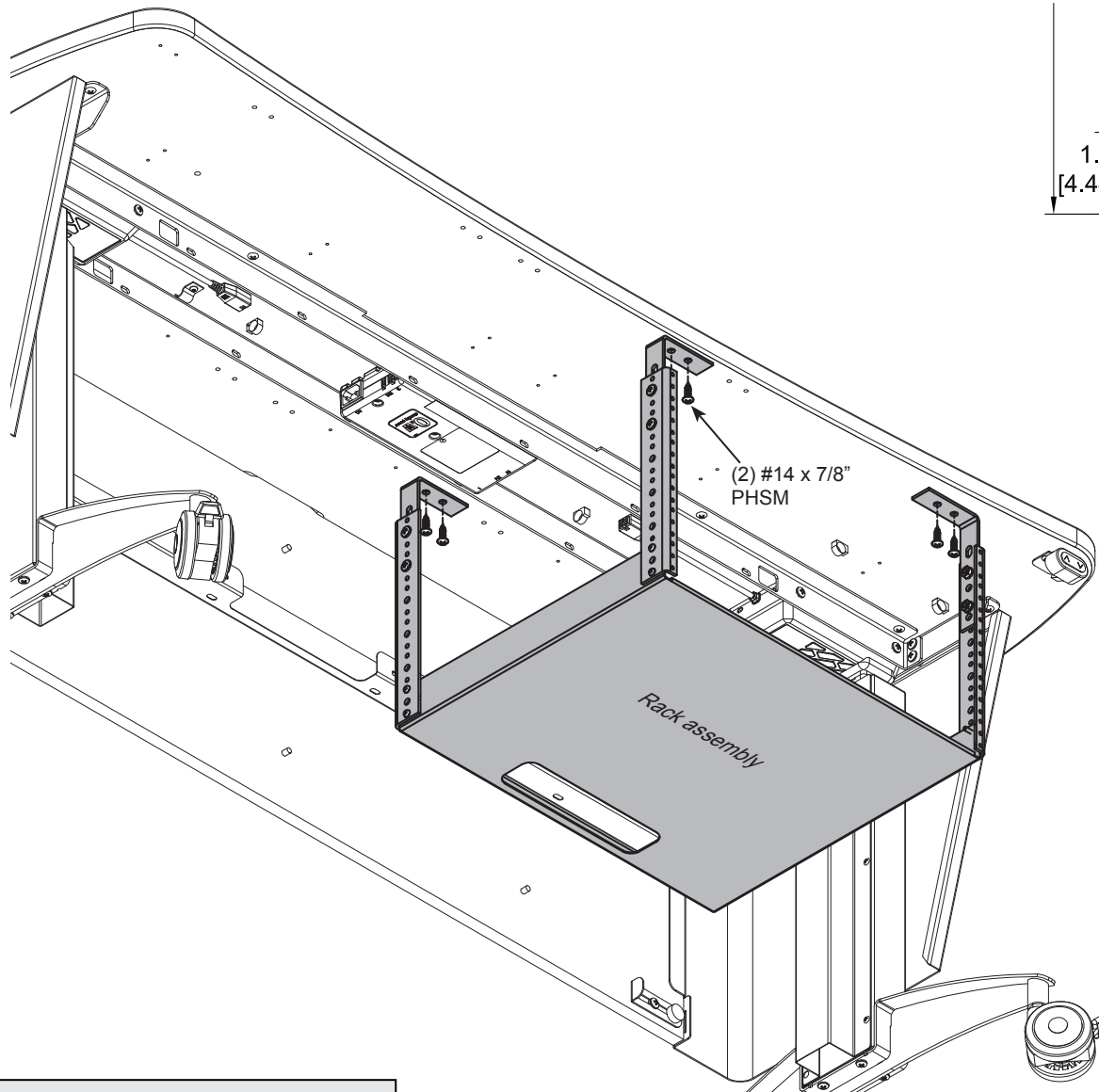

Figure 1

2. Install rack assembly

1. Determine the preferred position of the rack assembly (left, centered, or right).
2. Using the corresponding pre-drilled mounting holes under the worksurface, attach the rack assembly with (8) #14 x 7/8" PHSM screws. **Figure 2.** (2 through each "L" bracket).
3. Tighten screws securely.



Note: On the 48"W lectern, the 55496 Keyboard tray is not compatible with the 6RU Rack option. On the 60"W lectern, the keyboard tray is compatible with (1) 6RU rack option or (1) 38982 CPU sling.

Figure 2