

# Assembly Instructions:



205 Westwood Ave, Long Branch, NJ 07740  
 Phone: 866-94 BOARDS (26273) / (732)-222-1511  
 Fax: (732)-222-7088 | E-mail: sales@touchboards.com



(8) 026073  
 #8 x 3/4" PHSM Screws

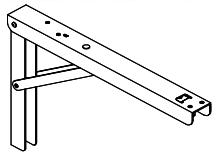

(2) 056886  
 12" x 8" Folding Brackets



(4) 044541  
 1/4-20 x 20mm JC Bolts



(1) 039622  
 2" Grommet



(1) 025039  
 4mm Hex Wrench



(8) 0100167  
 #8 x 1/2" PH Thrd  
 Ctg Screws

Before you begin, please make sure all parts and proper quantities are included. Any parts damaged during shipment must be reported within 15 days of receipt. To report information regarding damages or if you have any questions, please call 1-800-235-1262.

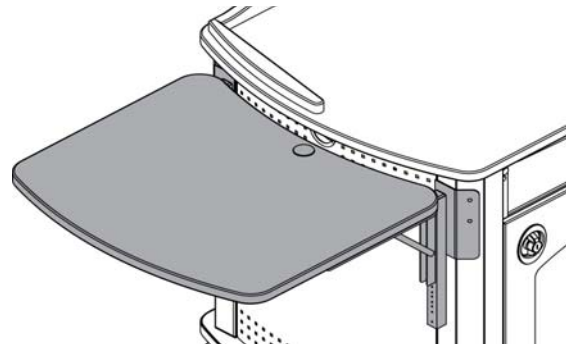

## LINK Cart Document Camera Shelf #55140



**Tools Required:**  
 4mm hex wrench (included)  
 Phillip screwdriver  
 Electric drill w/ #1 Phillips driver + extension

### 1. Attach support brackets

- Attach the left and right support brackets to the LINK cart as shown using (2) 1/4-20 x 20mm JC bolts per bracket. **Figure 1.**
- Do not tighten the JC bolts completely yet.

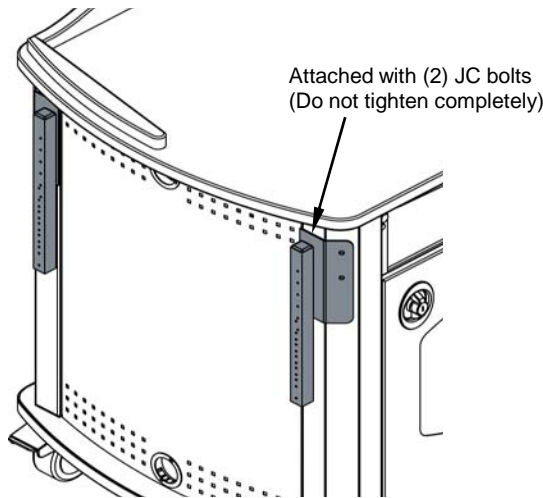

Figure 1

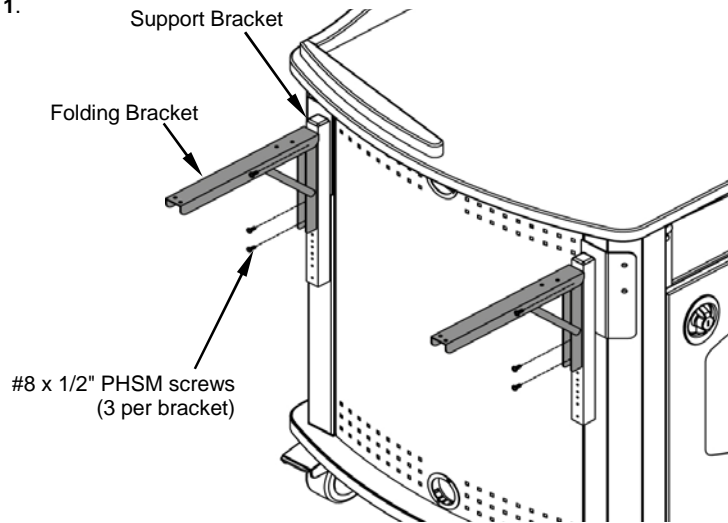

Figure 2

### 2. Attach folding brackets

- Determine the height you would like the shelf to be mounted.
- Open each folding bracket, and align the mounting holes at the desired height.
- With an electric drill, driver extension, and #1 Phillips driver, attach each folding bracket to the support brackets with (3) #8 x 1/2" PHSM screws. Tighten securely, but be careful not to strip out the holes. **Figure 2.**

### 3. Attach shelf to folding brackets

- A. With the folding brackets in the "UP" position, set the shelf on the brackets and align the mounting holes.
- B. Attach the shelf to the each folding bracket with (4) #8 x 3/4" PHSM screws and tighten securely with a Phillips screwdriver. **Figure 3.**
- C. Install the 2" grommet.
- D. Lower shelf (see instructions below.)
- E. With the shelf in the lowered position, tighten the previously installed JC bolts securely.

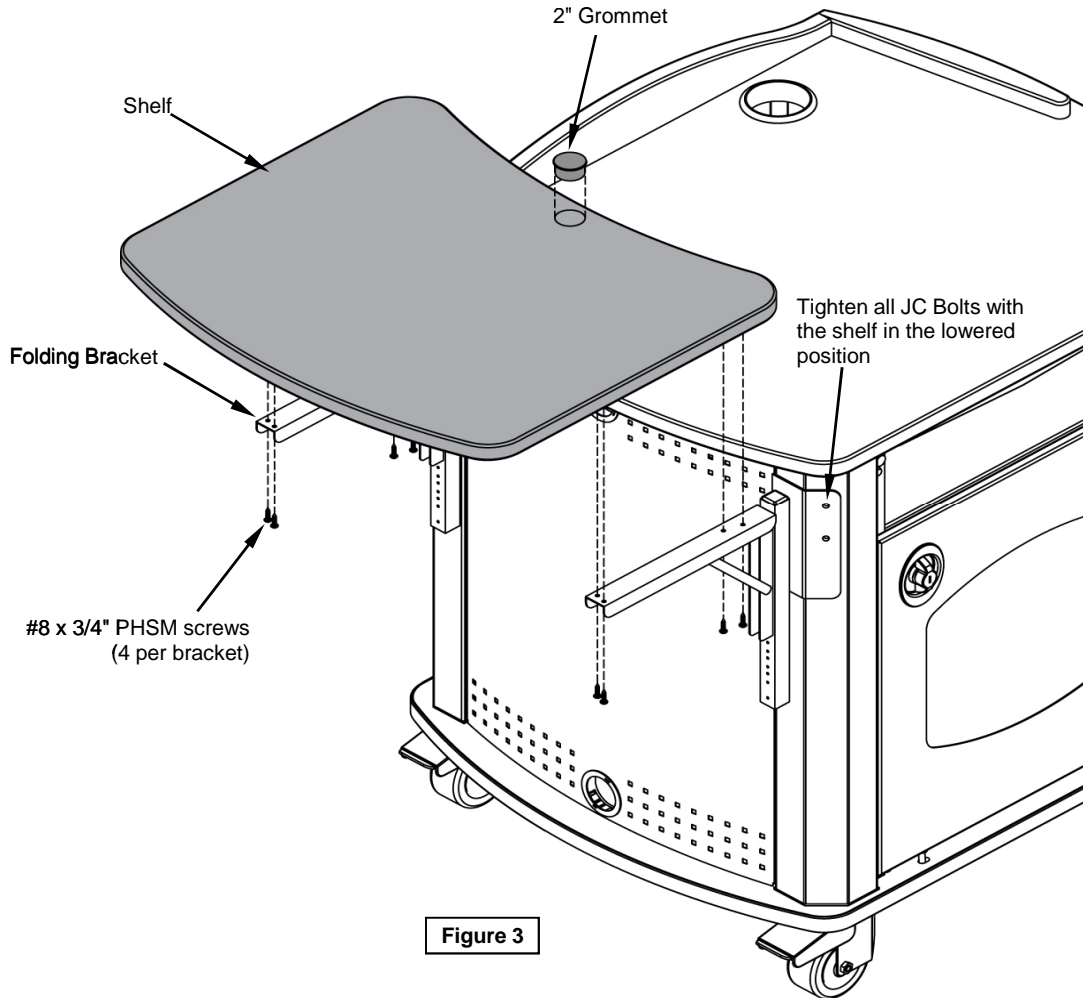

### Shelf operation

The shelf will automatically lock in place when lifted into a horizontal position. To flip the shelf down, push the release tab under each folding bracket at the same time, lift up slightly to disengage, then **slowly** lower the shelf. **Figure 4.**

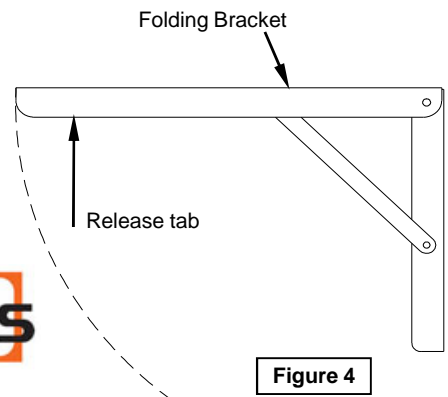

**CAUTION**  
Be careful not to pinch fingers  
while lowering the shelf.

**Touchboards**

205 Westwood Ave, Long Branch, NJ 07740  
Phone: 866-94 BOARDS (26273) / (732)-222-1511  
Fax: (732)-222-7088 | E-mail: sales@touchboards.com

**SPECTRUM**  
INDUSTRIES INC.