

Technical Specifications

55152

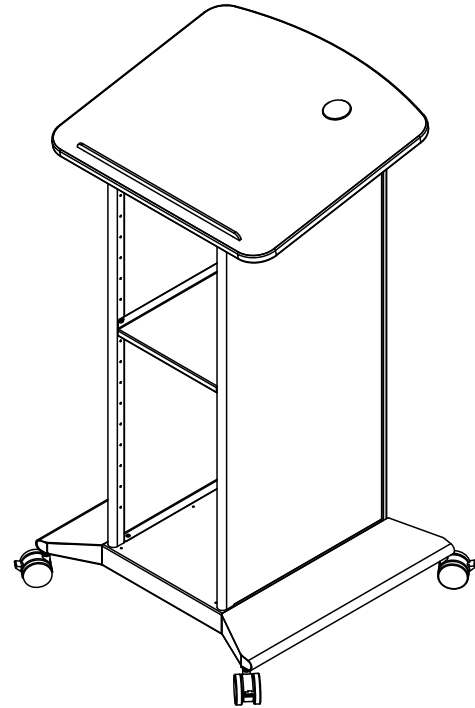
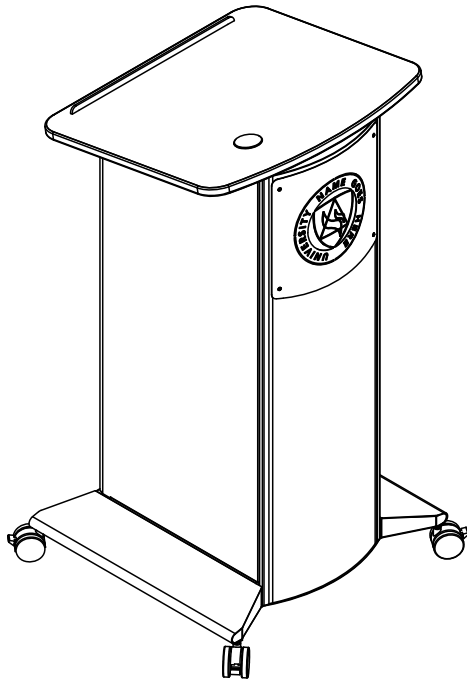

The Slim Lectern is Spectrum's solution to the minimalist (small footprint, thin and sleek) lectern movement. This lectern fully-supports AV equipment and provides a surprising amount of storage capacity for its size. Available with glides for stationary use, or casters for mobile use, the lectern can be configured to your specific environment using options like a 6RU rack cube for AV equipment, an underbridge for power modules or other surface-mount devices, a logo panel, and a second internal shelf for additional storage.

Features and Benefits

- Durable powder coated steel chassis provides a long-lasting finish
- Angled, scratch and impact-resistant, high-pressure laminate top provides durability, ergonomics, and styling
- Side panels are available in matching metal or laminate
- 3" twin-wheel casters provide easy mobility (all 4 locking)
- Glides available if mobility is not necessary or desired
- Removable audience-side panel provides easy-access to equipment
- Cable grommets keep wires and cords organized
- Internal shelf provides storage (one included standard)
- Optional removable rack cube (6RU) simplifies installation for any equipment configuration, provides mounting capabilities for multiple cooling fans, and provides the ability to integrate equipment remotely before being installed into the lectern at a later date.
- Optional customizable logo panel simplifies adding or changing logos
- Optional power module provides ability to charge laptops or phones
- Optional 2nd internal shelf provides additional storage
- Lectern ships fully-assembled for quick, simple integration and deployment
- Warranted to be free of all defects in materials and workmanship for 10 years
- Designed and assembled in Chippewa Falls, WI, USA

Color Options

Available in Spectrum Expressions colors.
See spectrumfurniture.com for complete color information.

Ordering Instructions

Spectrum has designed this product to receive the useful options shown here.
To ensure your options are ordered correctly please call 1-800-235-1262.

Construction

- The worksurface is constructed from 3/4" thick NAF (no-added formaldehyde) composite board with .030" high-pressure laminate on one face, and a balancing phenolic backer on the opposing face
- Wood side panels are constructed from 3/4" thick NAF (no-added formaldehyde) composite board with .030" high-pressure laminate on one face, and a balancing phenolic backer on the opposing face
- Metal components consist of 16 and 20-gauge steel
- Worksurface edges are covered with 3mm vinyl
- All metal components are finished with a scratch-resistant powder coat epoxy
- Each Slim Lectern is factory-assembled, and shipped on its own skid. Customer assembles casters / glides.

Specifications

Total internal area (nominal)	10.719"W [27.2 cm] x 17.75"D [45 cm] x 36.363"H [92.36 cm]
Steel Shelf	<ul style="list-style-type: none"> • (1) included • Vertical adjustability: 2" spaced holes in side panels
3" Twin Wheel Casters	Weight capacity 90 lb [40.9 kg] each
Certifications / Compliance	<ul style="list-style-type: none"> • SCS Indoor Advantage Certified • Meets or exceeds applicable ANSI-BIFMA test standards
Unit weight (nominal)	58 lb [40.4 kg] (lectern w/ steel side panels) 74 lb [33.6 kg] (lectern w/ laminate side panels)
Shipping weight (nominal)	83 lb [37.7 kg] (lectern w/ steel side panels) 99 lb [45 kg] (lectern w/ laminate side panels)

Specifications subject to change without notice

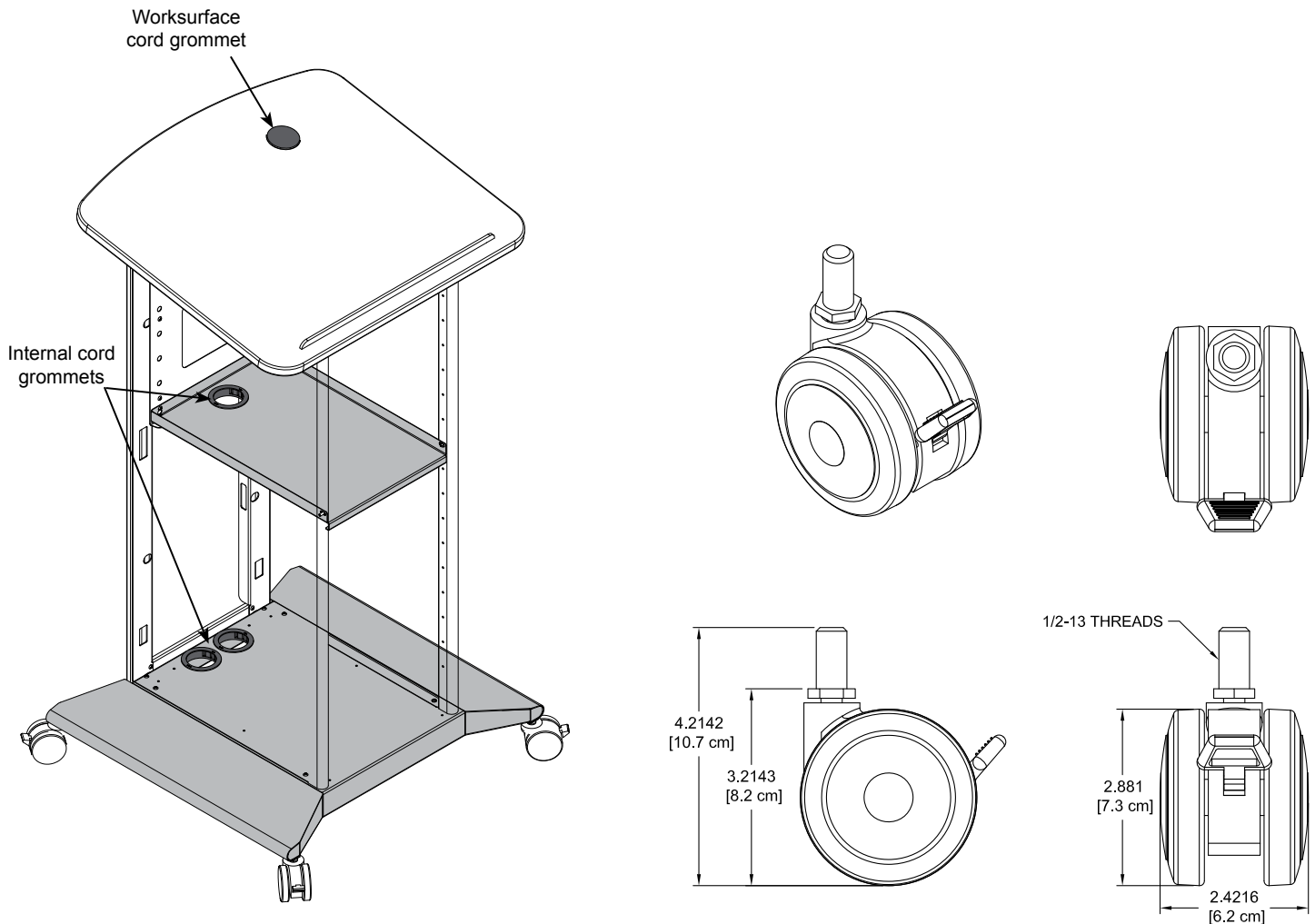

Side Panel Style

- ORDER CODE 1 = Matching Metal
- ORDER CODE 2 = Matching Laminate

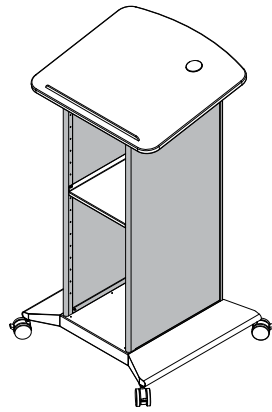

Mobility Options

ORDER CODE 01 = 3" Twin-wheel Casters

ORDER CODE 02 = Glides

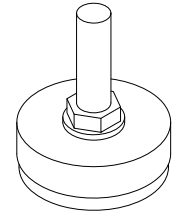
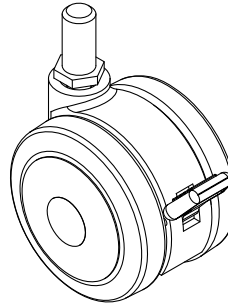

Underbridge Options

ORDER CODE 0 = None

ORDER CODE 1 = Underbridge-Blank

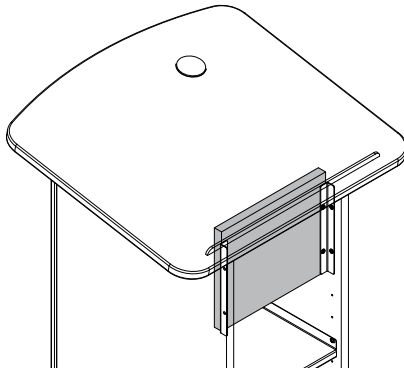

- ORDER CODE 2 = Underbridge w/ Power Module - Black
- ORDER CODE 3 = Underbridge w/ Power Module - Silver
- ORDER CODE 4 = Underbridge w/ Power Module - White

- (2) AC receptacles (tamper-resistant)
- (2) USB ports rated at 2.1A each (10.5 watts)
- Aluminum housing and flange
- 10' 14AWG *3C power cord
- When specified, the Power Module is mounted in an "underbridge" panel (10.875"W x 9"H) below the worksurface
- Panel cutout size: 5.65"W x 1.65"D
- ETL-certified

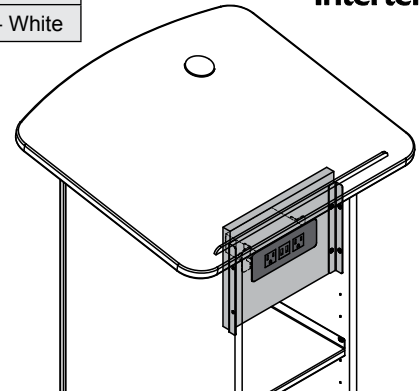

Rack Cube

- ORDER CODE 0 = None
- ORDER CODE 1 = 6RU Vertical Rack Cube

- 6RU of rack space
- Provides the ability to integrate equipment remotely before installation into the lectern
- Polyethylene slides on bottom for easy removal / installation
- Rack equipment mounts vertically
- Color: black

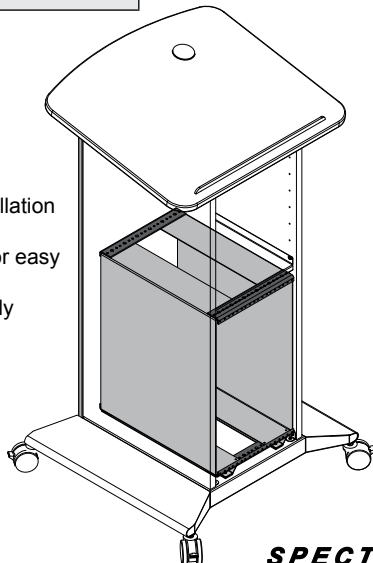

Customized Logo Panel

- ORDER CODE 0 = None
- ORDER CODE 1 = Yes-with matching laminate backer
- ORDER CODE 3 = Yes-with black laminate backer
- ORDER CODE 4 = Yes-with white laminate backer

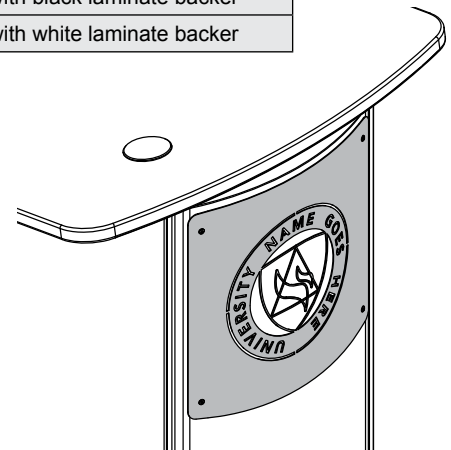

Slim Lectern
w/ 3" Twin wheel casters
(shown with optional accessories)

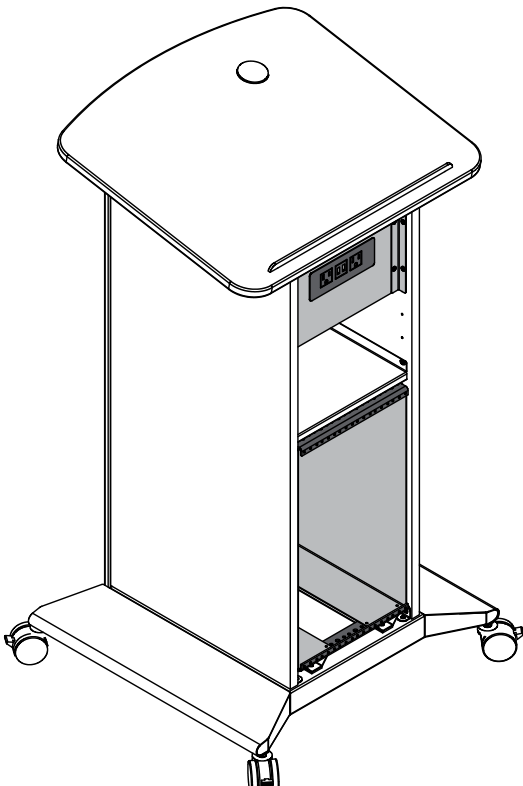

Removable
audience-side panel

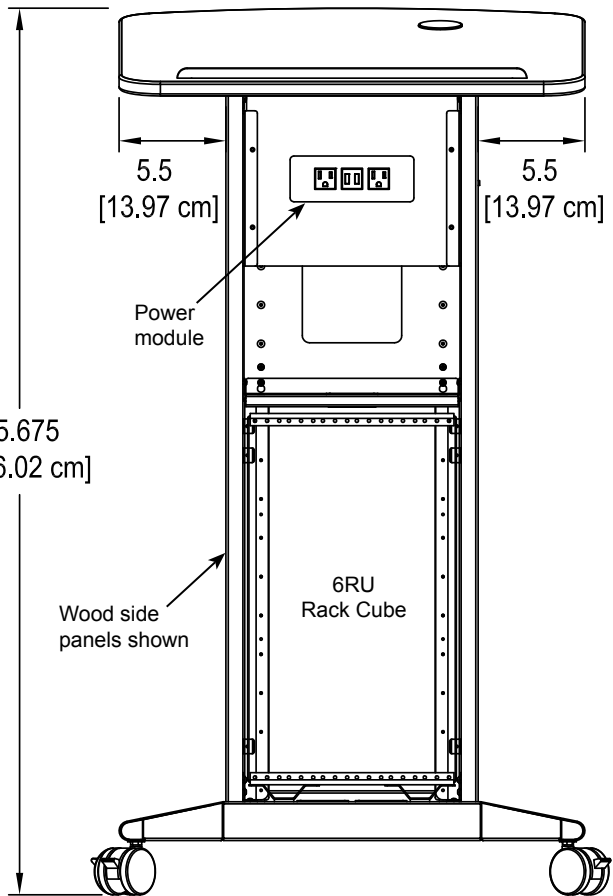
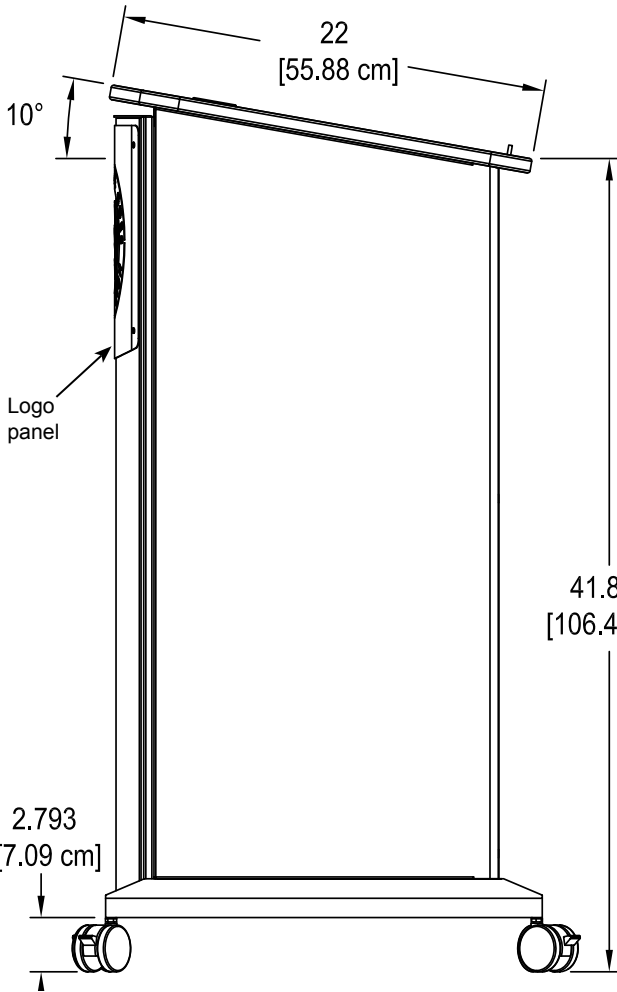
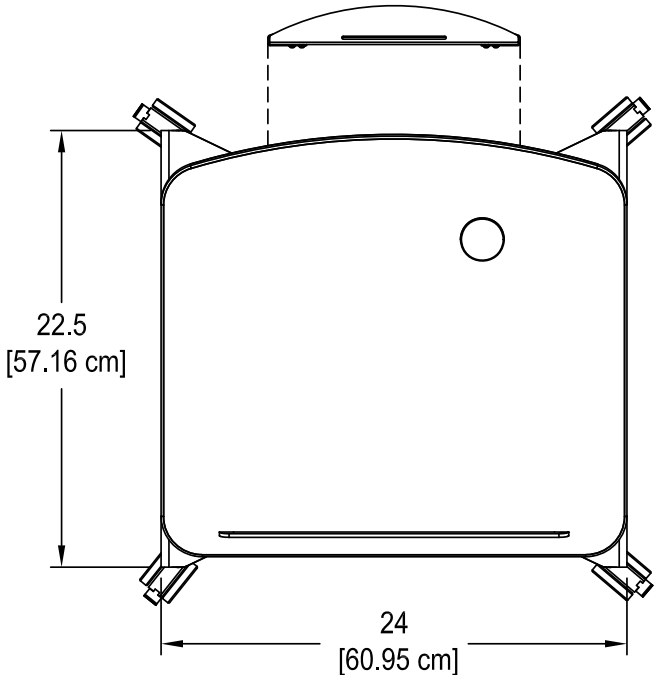

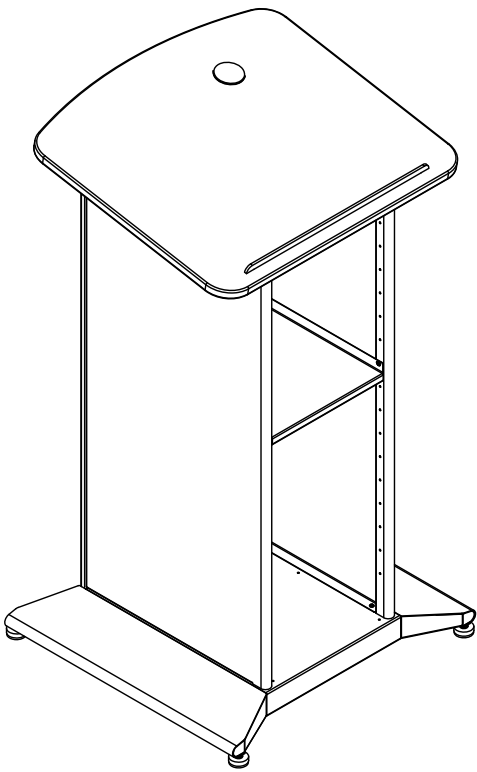

Slim Lectern
w/ glides

Removable
audience-side panel

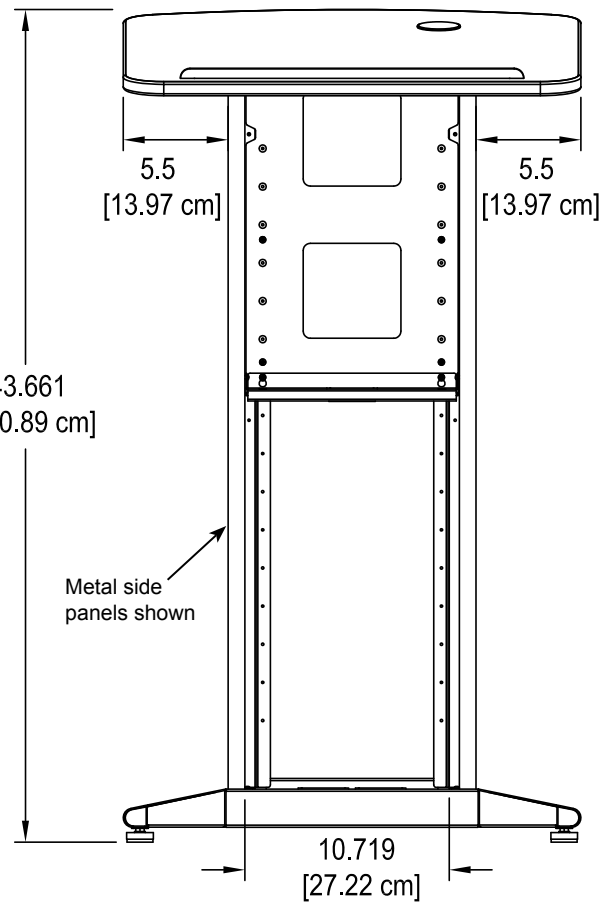
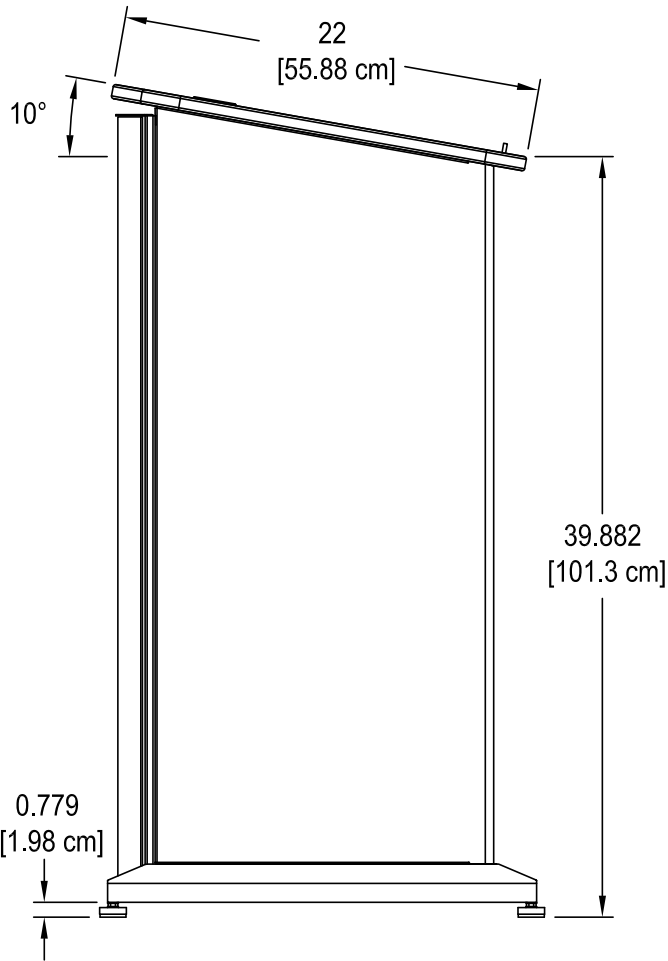
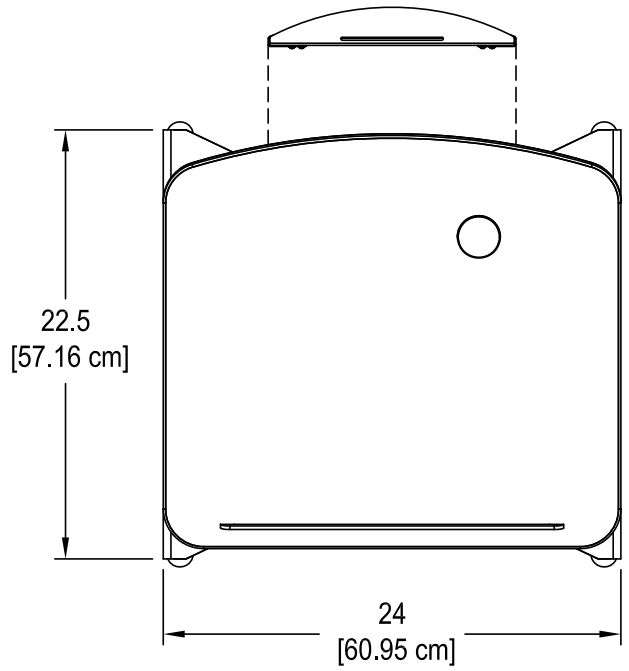

Accessories (Available separately after initial configured purchase.)

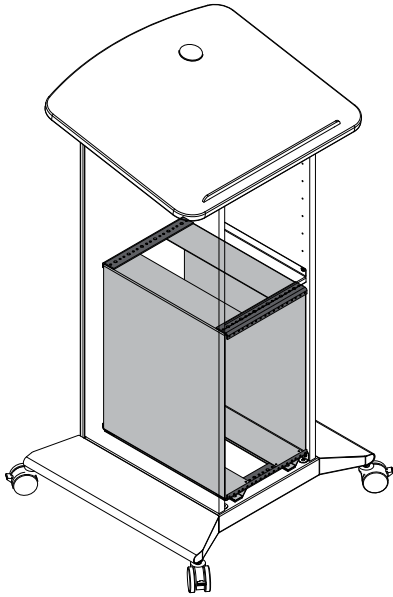

6RU Vertical Rack Cube - 97524

- Provides the ability to integrate equipment remotely before installation into the lectern
- Polyethylene slides on bottom for easy removal / installation
- Rack equipment mounts vertically
- Color: black

Rack rail:	6RU front and rear
Rack cube dimensions:	10.75"W [27.3 cm] x 17.078"D [43.38 cm] x 20"H [50.8 cm]
Available equipment depth:	16.281"D [41.35 cm]
Unit weight:	19 lb [18.63 kg]
Shipping weight:	20 lb [9.08 kg]

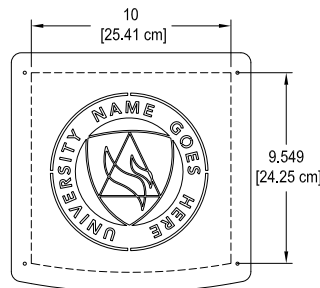
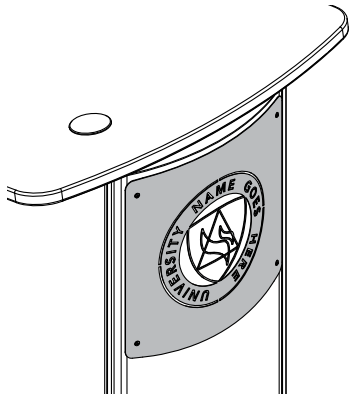
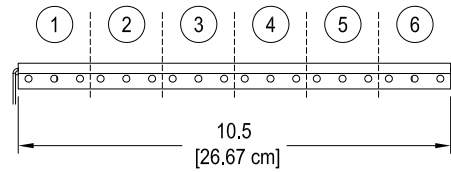

Customized Logo Panel - 55513

- Attaches to audience-side panel
- Available with black, white, or matching laminate backer
- To get panel customized-contact Spectrum for details
- New logos require a first time logo charge
- 20ga steel
- Customer-installed

Panel dimensions:	12"W [30 cm] x 12"H [30 cm] x .06"D [1.5 mm]
Available logo area:	10"W [25.41 cm] x 9.549"H [24.25]
Unit weight:	1.5 lb [.681 kg]
Shipping weight:	2.5 lb [1.14 kg]

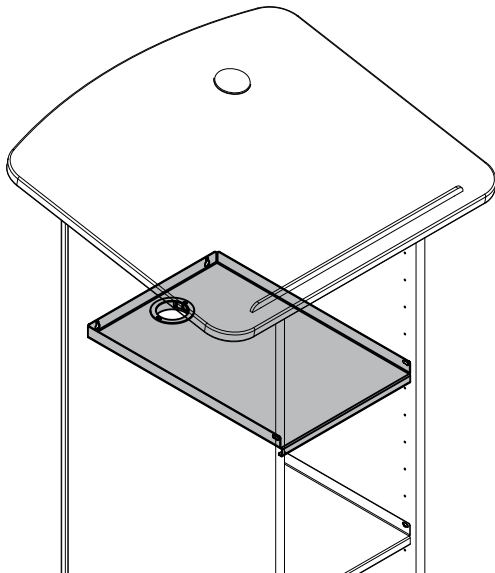

Additional Shelf - 55514

- Provides additional storage
- Includes 2" grommet for cord management
- 20ga steel
- Customer-installed

Dimensions:	11.1"W [28.2 cm] x 16.6"D [42.2 cm] x 1.5"H [3.8 cm]
Unit weight:	2.5 lb [1.14 kg]
Shipping weight:	3.5 lb [1.59 kg]

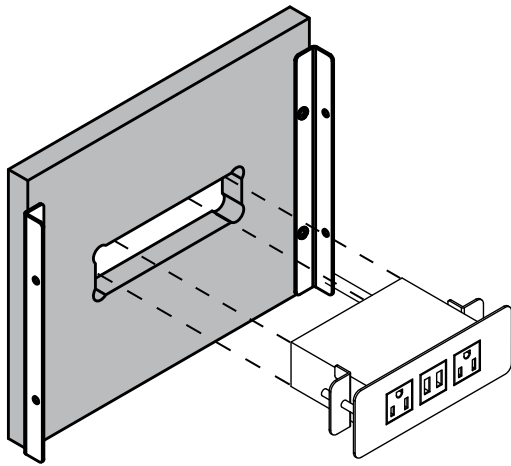

Underbridge with Power Module - 96516

- (2) AC receptacles (tamper-resistant)
- (2) USB ports rated at 2.1A each (10.5 watts)
- Aluminum housing and flange
- 10' 14AWG *3C power cord
- Power module is ETL-certified
- Scratch, impact, fingerprint-resistant, high-pressure textured black laminate face
- Includes mounting brackets and hardware
- Customer installed



Panel dims:	10.875"W [27.6 cm] x .75"D [1.9 cm] x 9"H [22.86 cm]
Cutout:	5.65"W [14.35 cm] x 1.65"D [4.19 cm]
Power cord:	10' [305 cm] 14AWG *3C power cord
Power receptacles:	125V, 60hz, 15A tamper-resistant
USB charging ports:	2.1A (10.5W) (not data-compatible)
Module Dims:	6.38"W [16.2 cm] x 2.36"D [6 cm] x 3.54"H [9 cm]
Unit weight:	4.5 lb [2 kg]
Shipping weight:	5.5 lb [2.5 kg]

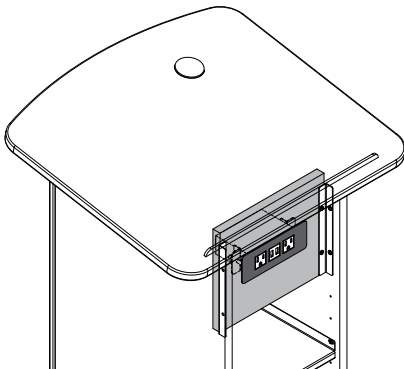

Underbridge-Blank - 96515

- Blank panel simplifies adaptation to technology changes or upgrades
- Scratch, impact, fingerprint-resistant, high-pressure textured black laminate face
- Includes mounting brackets and hardware
- Customer installed

Panel dims:	10.875"W [27.6 cm] x .75"D [1.9 cm] x 9"H [22.86 cm]
Max cutout area:	9.75"W [24.77 cm] x 7"H [17.78 cm]
Unit weight:	2.5 lb [1.1 kg]
Shipping weight:	3.5 lb [1.59 kg]

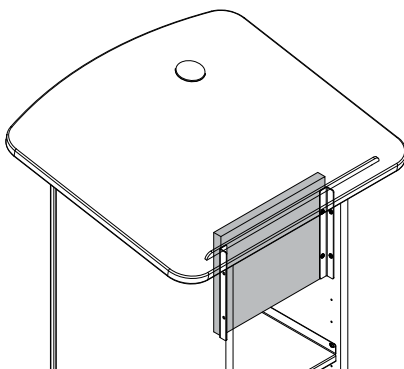
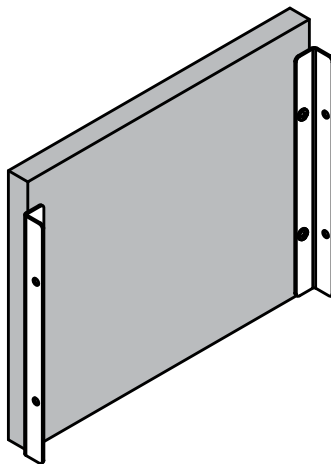

If a custom cutout is needed, contact Spectrum to specify cutout size.

Cutouts can be made in the blank insert panel by the customer after the lectern has been purchased, but are only recommended within the maximum cutout area listed.

Rack-mount Accessories

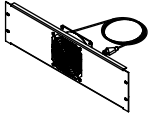

Single Fan - 3RU - 97507

- 50 cfm
- 120V~50/60 Hz, 15/13W
- RoHS
- 19"W [48.27 cm] x 1.56"D [3.97 cm] x 5.25"H [13.33 cm]
- Shipping weight: 3.78 lb [1.7 kg]

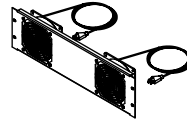

Double Fan - 3RU - 97506

- 100 cfm
- 120V~50/60 Hz, 15/13W
- RoHS
- 19"W [48.27 cm] x 1.56"D [3.97 cm] x 5.25"H [13.33 cm]
- Shipping weight: 5.47 lb [2.5 kg]

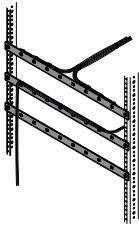

Wire Lace Kit - 95517

- Provides wire management
- Mounts to standard rack rails
- Includes (3) lace straps and mounting screws
- Includes (12) 5.5" zip ties
- Shipping weight: 1.25 lb [.57 kg]

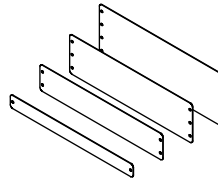

Rack-Mount Blanks

1RU - 97510 **3RU - 97512**
2RU - 97511 **4RU - 97513**

- Fills rack spaces where components are not needed
- 16 ga steel
- Shipping weight: <1 lb [.45 kg]

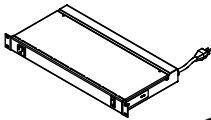

9-Outlet Power Strip - 1RU - 99021

- 8 outlets rear (breaker-protected)
- 1 convenience outlet front
- 115VAC, 60 Hz, 15 amps max
- 9' power cord
- Front LED power switch
- Enhanced surge protection
- ETL-listed, UL-listed
- 19"W [48.27 cm] x 9.25"D [23.5 cm] x 1.74"H [4.41 cm]
- Shipping weight: 8.7 lb [3.9 kg]

Warranty

We will make it right for you!

Spectrum is committed to provide complete customer satisfaction. Each of our products is manufactured from the best materials available and each product is stringently monitored throughout the production process through our Quality Management System.

We expressly warrant that Spectrum products will be of good quality and workmanship and free from defect for the period set out in the warranty table below from the date of delivery. This warranty shall not apply to defects or damage resulting from normal wear and tear, misuse, or unintended use, failure to follow instructions related to the product's installation or intended use, abuse, neglect, improper care, modification or repair not authorized by Spectrum, or any other cause outside the control of Spectrum. Spectrum will, at its sole option, either repair or replace the defective product.

This warranty is exclusive; no other warranty, written or oral, is expressed or implied. This warranty is given by Spectrum to Buyer or Buyer third party end user and to no other person or legal entity. No Spectrum dealer, distributor, partner, reseller, agent or employee is authorized to make any modification or addition to this warranty.

NOTWITHSTANDING ANYTHING TO THE CONTRARY, SPECTRUM WILL NOT UNDER ANY CIRCUMSTANCES BE LIABLE FOR INDIRECT OR LIQUIDATED DAMAGES, INCLUDING CONSEQUENTIAL, INCIDENTAL AND SPECIAL DAMAGES. IN NO EVENT SHALL SPECTRUM'S LIABILITY, WHETHER UNDER CONTRACT OR WARRANTY, IN TORT OR OTHERWISE, EXCEED THE PURCHASE PRICE RECEIVED BY SPECTRUM FOR THE PRODUCT AT ISSUE AND "RECALL ACTION" EXPENSES. SPECTRUM SHALL NOT BE SUBJECT TO ANY OTHER OBLIGATIONS OR LIABILITIES, WHETHER ARISING OUT OF BREACH OF CONTRACT, WARRANTY, TORT (INCLUDING NEGLIGENCE AND STRICT LIABILITY) OR OTHER THEORIES OF LAW, WITH RESPECT TO PRODUCTS SOLD OR SERVICES RENDERED BY SPECTRUM, OR ANY UNDERTAKINGS, ACTS OR OMISSIONS RELATING THERETO.

Our Customer Service Department is ready to provide immediate attention to any questions, comments or concerns. They are available to answer your calls Monday through Friday from 7 am to 5 pm CST. In addition your product comments or concerns are welcome via e-mail at: spectrum@spectrumfurniture.com.

Warranty Table

Item	Warranty Period
Desk, table, cart and lectern chassis	10 Years
Electrical	2 Years
Flat panel monitor arms / gas spring / general parts	2 Years
Adjustable crank / electric legs and accessories	2 Years
Flat panel desk gas spring cylinders	2 Years
Height adjustable columns, lifts & accessories	2 Years
Casters & wheels	2 Years
Keyboard, mouse, trays	2 Years
Locks & keys	2 Years
Tubs, totes and other accessories	1 Year
Chairs	7 Years
Structural components, including gas cylinders, wood, metal and plastic parts (i.e., chair frames, bases and control handles)	
Consumable items (i.e., casters, glides, etc.)	
In-stock upholstery	5 Years
Customer supplied material	No Warranty



Spectrum Industries Inc.
is Certified ISO 9001:2015