

Technical Specifications

55213

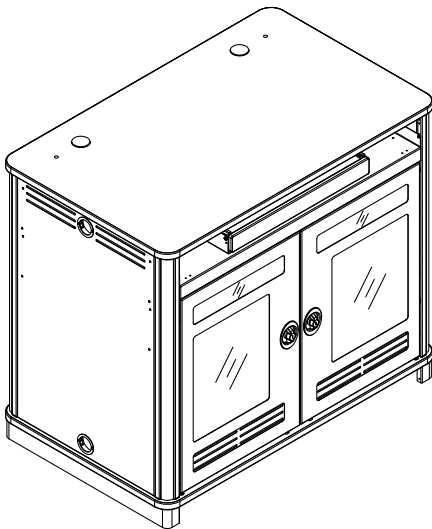

Shown with plain work surface, metal side panels, and centered keyboard tray

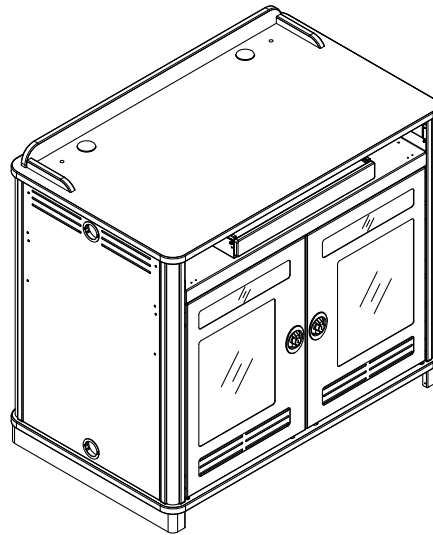

Shown with surround, metal side panels, and centered keyboard tray

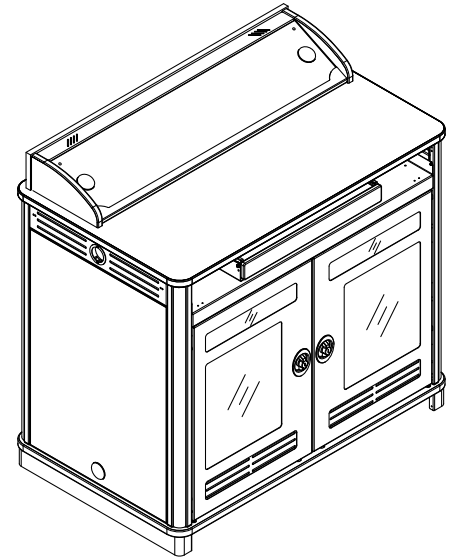

Shown with Overbridge Control Console, laminate side panels, and centered keyboard tray

The Director Lectern is used when multimedia equipment rack-mount storage is required. One or two optional rack cubes provide 13RU (each) of front and rear rack space and are easily accessible from the instructor and audience-sides. The work surface is available in plain, surround, or with an overbridge. Overbridge models use an overbridge console specifically for the installation of training and presentation controls. Other options include a keyboard tray, additional 2RU rack rails, logo panel, flip-up shelves, and work surface power module. The lectern is mobile with standard twin-wheel casters, or stationary with an optional Toe kick kit.

Features and Benefits

- Optional removable rack cubes (13RU front and 13RU rear) simplifies installation for any equipment configuration, provides mounting capabilities for multiple cooling fans (one or two cubes can be installed), and provides the ability to integrate equipment remotely before being installed into the lectern at a later date.
- Durable powder coated steel chassis provides a long-lasting finish
- Scratch and impact-resistant high-pressure laminate top provides a durable, useful work surface for instructors
- 3" swivel Twin-Wheel (TW) casters provide mobility (2 locking)
- Locking instructor-side doors provide security, the ability to monitor internal components, and can be removed via quick-release to provide full-access to rack equipment.
- Work surface surround provides privacy and styling
- Overbridge version allows custom cutouts and installation of presentation controllers
- Two 2" cable grommets on work surface (two on overbridge) provide cable access to user
- Side panels are available in matching metal or laminate
- Panel under keyboard storage area provides security
- Ventilation throughout lectern helps keep equipment cool, preventing overheating, and extending device life
- Cable grommets keep wires and cords organized
- Work surface and base panel vinyl edging protects walls and furniture
- Removable audience-side panel provides access to internal equipment
- Optional flip-up shelf provides a convenient additional work surface (two height positions)
- Optional keyboard tray or 2RU rack rail kit can be installed under work surface
- Optional customizable logo panel simplifies adding or changing logos
- Optional Toe kick kit with access panel is available to anchor the lectern to the floor when mobility is not necessary or required (customer-installed)
- Warranted to be free of all defects in materials and workmanship for 10 years
- Designed and assembled in Chippewa Falls, WI, USA

Color Options

Available in Spectrum Expressions colors. See spectrumfurniture.com for complete color information.

Ordering Instructions

Spectrum has designed this product to receive the useful options shown here. To ensure your options are ordered correctly please call 1-800-235-1262.

Construction

- The worksurface and base panel are constructed from 1" thick NAF (no added formaldehyde) composite board with .030" high-pressure laminate on one face, and a balancing phenolic backer on the opposing face
- Metal components consist of 16-gauge steel
- Worksurface edges are covered with 3mm vinyl edgeband
- All metal components are finished with a scratch-resistant powder coat epoxy
- Solid wood corner trim
- Each Director Lectern is factory-assembled with casters, packaged, and shipped on its own skid. Customer-installed base skirt.

Specifications

Upper storage area (nominal)	40.57"W [103 cm] x 15.75"D [40 cm] x 4.72"H [11.98 cm]	
Lower internal area (nominal)	40.75"W [103.5 cm] x 24.4"D [62 cm] x 28.7"H [72.9 cm]	
Optional rack cube(s)	13RU each (one or two cubes can be installed)	
3" Twin wheel casters	Weight capacity 165 lb [74.9 kg] each	
Certifications / Compliance	<ul style="list-style-type: none"> • SCS Indoor Advantage Certified 	<ul style="list-style-type: none"> • Meets or exceeds applicable ANSI-BIFMA test standards
Unit weight (nominal)	198 lb [89.9 kg]	
Shipping weight (nominal)	N/A	

Specifications subject to change without notice

Heat Dissipation:

- The passive heat dissipating system of this lectern is sufficient for up to approximately 1600 BTU's of internal heat. Anything higher may require a forced air system.
- If a forced air system is anticipated, rack mounted intake fans can be installed directly behind the instructor-side vented door panels to draw air into the rack space.
- The two 3.25" wire management grommet caps in the base panel can also be removed to increase airflow.

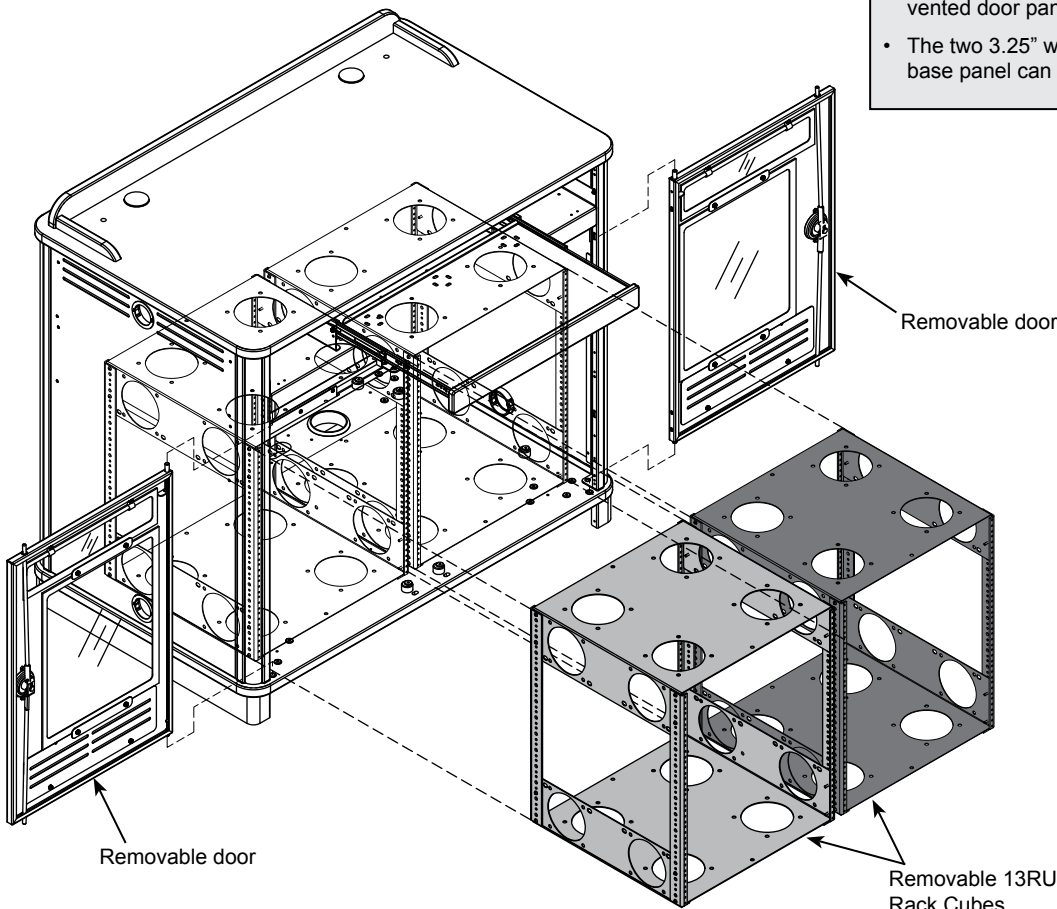

Audience-side view

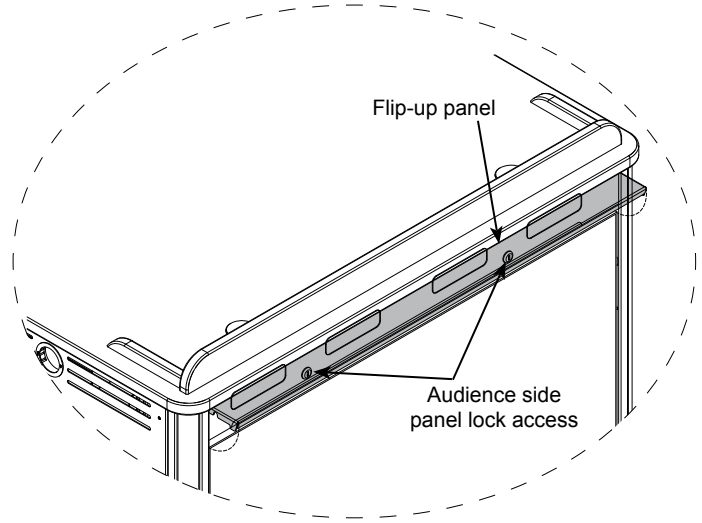
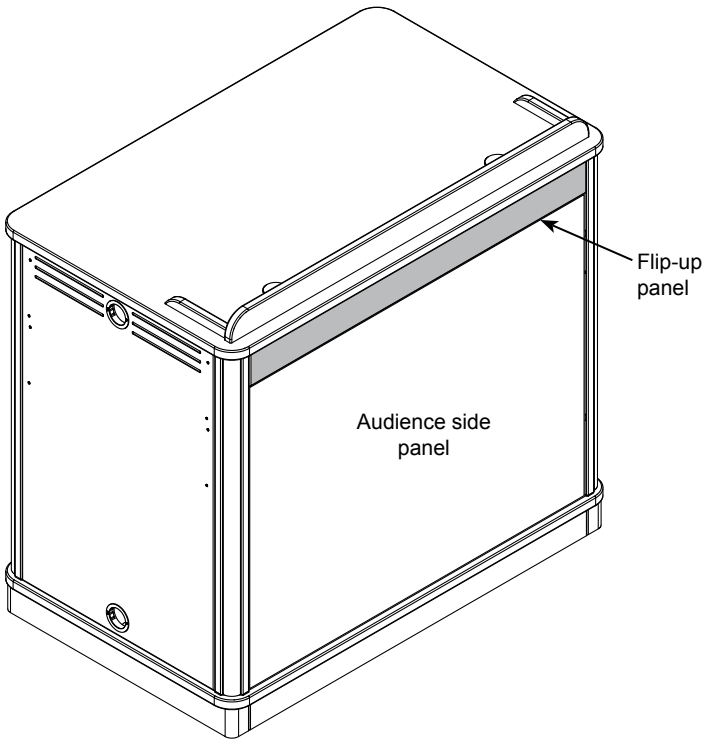

Bottom view

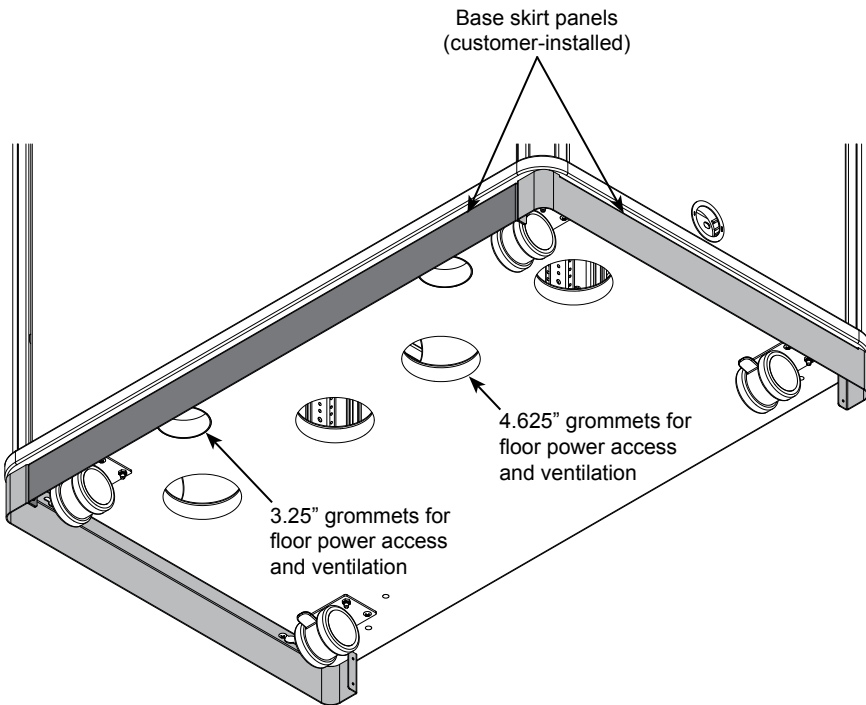

3" Twin-Wheel caster (TW)

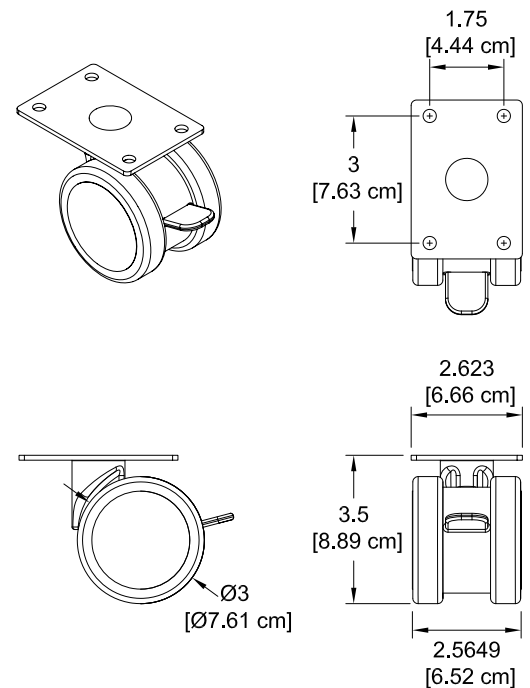

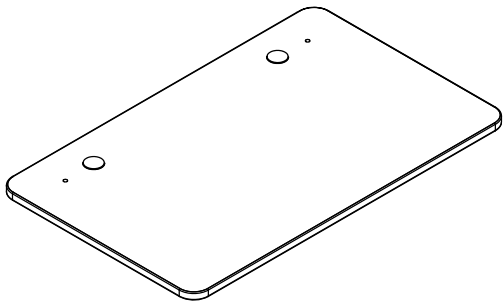

ORDER CODE P1 =	Worksurface only (plain)
------------------------	--------------------------

- Two 2" grommets (with covers)
- Two .375" holes (with plugs) for worksurface monitor arm mounting

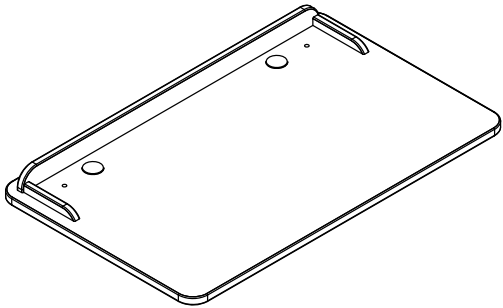

ORDER CODE S1 =	Surround
------------------------	----------

- Surround
- Two 2" grommets (with covers)
- Two .375" holes (with plugs) for worksurface monitor arm mounting

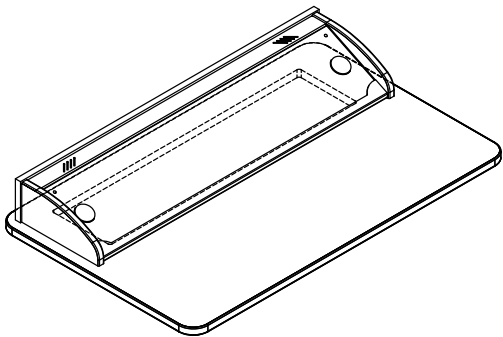

ORDER CODE B1 =	Overbridge Control Console™
------------------------	-----------------------------

- Overbridge with blank insert panel for custom cutouts (see p.13 for dimensions). (Overbridge not available separately)
- Two 2" grommets (with covers)

13RU Rack Cube(s)

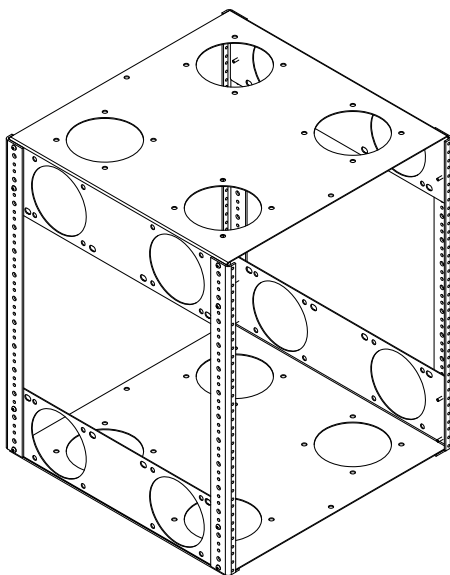

ORDER CODE 0 =	None
ORDER CODE 4 =	Yes, one rack cube
ORDER CODE 6 =	Yes, two rack cubes

13RU Rack Cube(s)

- Provides the ability to integrate equipment remotely before installation into the lectern
- Up to two rack cubes can be installed into the Director Lectern
- Polyethylene slides on bottom for easy removal
- Can be secured to base panel
- Cooling fan compatible
- Color: black
- Factory-installed

Rack rail:	13RU front and rear
Dimensions:	19.125"W [48.58 cm] x 19.031"D [48.34 cm] x 23.125"H [58.74 cm]
Mounts for cooling fans:	Compatible with most 4.7" fans with 4.13" mounting hole spacing (12 mounting locations available)
Unit weight:	25 lb [11.4 kg]

Note: If rack rail mounting is needed in the lectern, the rack cube must be specified. The lectern does not provide any rack-mount capabilities without the cube.

Flip-Up Shelf

ORDER CODE 0 =	None
ORDER CODE 4 =	On both sides (two shelves) Matching laminate
ORDER CODE 9 =	On both sides (two shelves) Chalk white dry erase

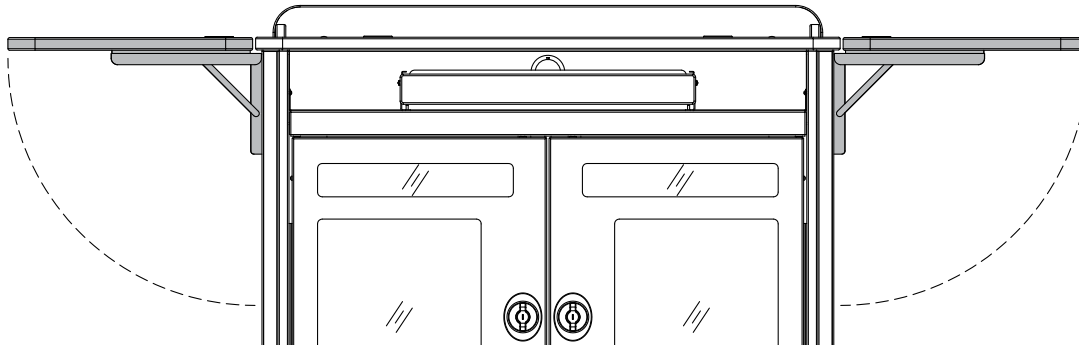

ORDER CODE 3 =	On Left (one shelf) Matching laminate
ORDER CODE 8 =	On Left (one shelf) Chalk white dry erase

ORDER CODE 2 =	On Right (one shelf) Matching laminate
ORDER CODE 7 =	On Right (one shelf) Chalk white dry erase

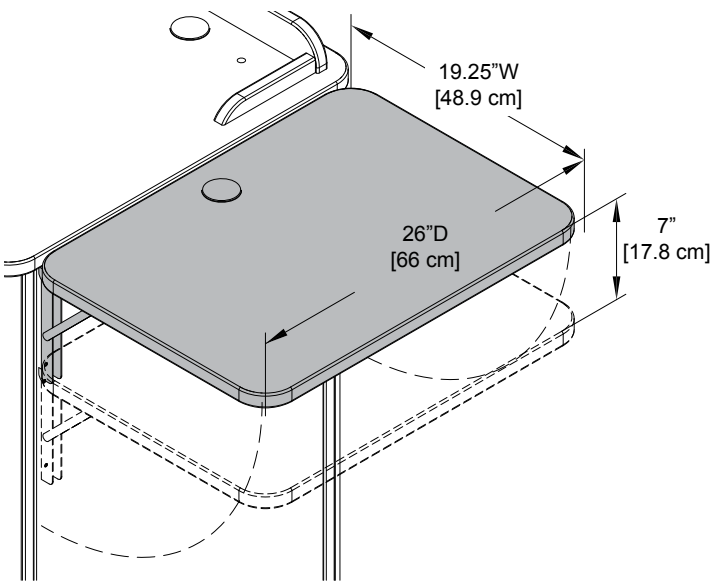

Flip-Up Shelf

- Matching laminate
- Shelf hinges lock into place in the upright position
- Includes 2" grommet
- Two height-positions available
- Available in White Chalk Dry Erase laminate. Flip-up shelves configured with white laminate will have the same edgeband color as the worksurface and base panel.
- Factory-installed level with worksurface (Customer can install to lower position if necessary)

Weight capacity:	35 lb [15.9 kg]
Dimensions:	19.25"W [48.9 cm] x 26"D [66 cm] x 1"H [2.54 cm]
Height positions available:	• 41"H [104.1 cm] (level with worksurface) • 34"H [86.4 cm]

Note: Power and communication wiring for document cameras, laptop computers, and/or projectors placed on the flip-up shelf should be routed on top of the audience-side of the shelf. Use of the shelf grommet hole for wiring will result in pinching of the cords when the shelf is folded.

Base

ORDER CODE 00 = Skirt only

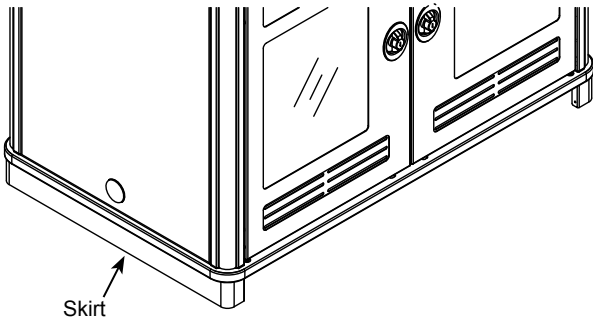

ORDER CODE TK = Skirt with Toe Kick Kit

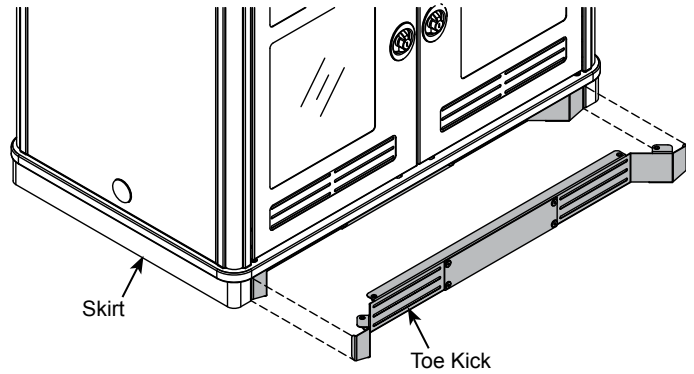

Toe Kick Kit

- Attaches to floor and lectern when mobility is not necessary or desired (floor fasteners not included)
- Conceals casters
- Includes access panel
- Slots provide ventilation
- Customer-installed

Side Panel Style

ORDER CODE 1 = Matching Metal

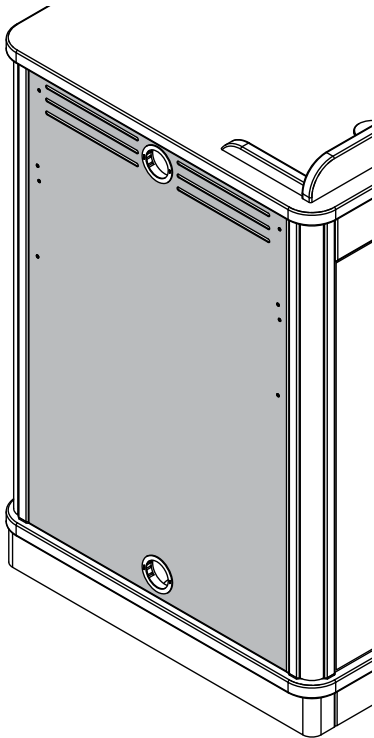

Venting: Metal panel has integrated vents.

ORDER CODE 2 = Matching Laminate

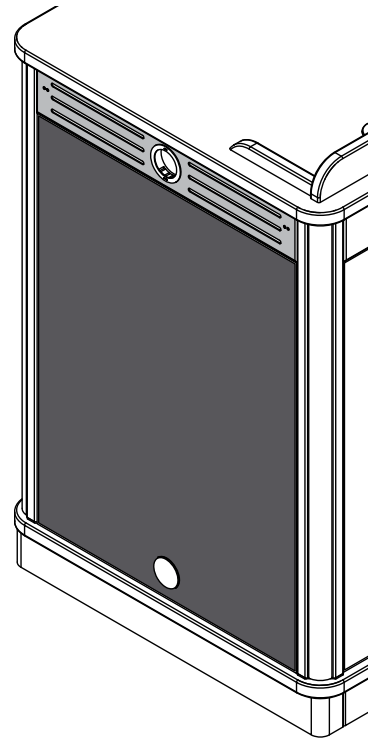

Venting: The narrow vented upper metal panel and grommet holes on base panel provide airflow. The laminate panel itself does not have integrated vents.

ORDER CODE 0 = None

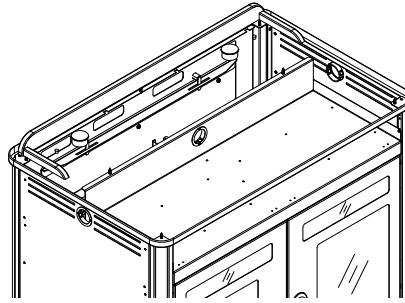

Keyboard Tray

- Installed under worksurface
- Tray can be used as a keyboard tray or flipped and used as a storage drawer
- Wire management slots in tray

Slides: 14" [35.6 cm] full-extension
 Weight capacity: 25 lb [11.4 kg]
 Dimensions: 22"W [55.9 cm] x 13.8"D [35 cm] x 2.1"H [5.3 cm]

ORDER CODE 1 = Keyboard Tray - Left

ORDER CODE 3 = Keyboard Tray - Centered

ORDER CODE 2 = Keyboard Tray - Right

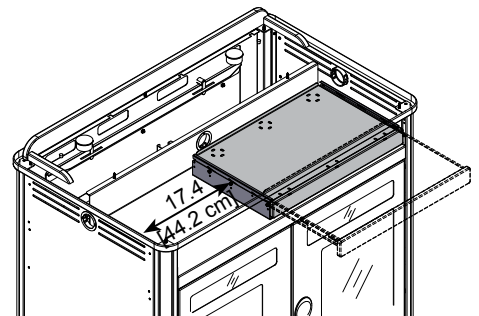
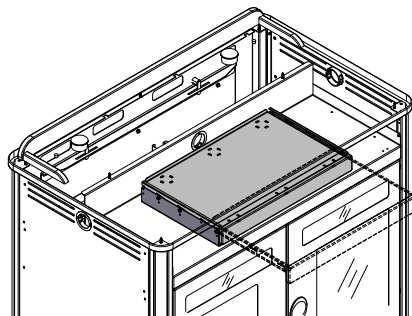
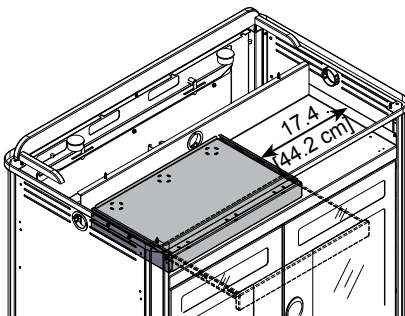

2RU Rack Rail Kit

- Adds an additional 2RU to lectern
- Customer-installed on mid-panel on left, or right-side
- The Media Director Lectern can accommodate up to two rack rail kits

Note: The Rack Rail Kit and Keyboard Tray are not compatible together.

ORDER CODE 4 = 2RU - Left

ORDER CODE 6 = 2RU - Left and Right

ORDER CODE 5 = 2RU - Right

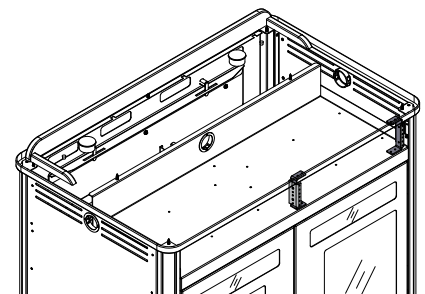
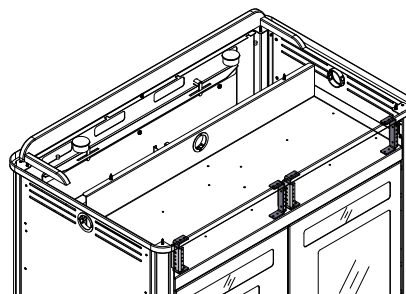
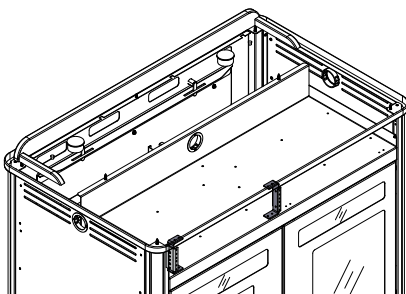

ORDER CODE 0 =	None
ORDER CODE 1 =	Yes (with <u>matching laminate</u> backer)
ORDER CODE 3 =	Yes (with <u>black laminate</u> backer)
ORDER CODE 4 =	Yes (with <u>white laminate</u> backer)



Customized Logo Panel

- Attaches to audience-side of lectern
- To get panel customized-contact Spectrum for details
- New logos require a first-time logo charge

Dimensions: 30"W [76.2 cm] x 12"H [30.48 cm]
 Available logo area: 28"W [71.1 cm] x 10"H [25.41 cm]

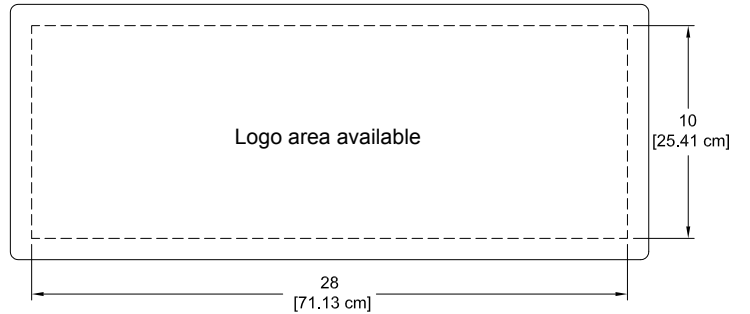

ORDER CODE 0 = None

ORDER CODE 1 = Power Module - Black

ORDER CODE 2 = Power Module - Silver

ORDER CODE 3 = Power Module - White

- Factory-installed
- (2) AC receptacles (tamper-resistant)
- (2) USB ports rated at 2.1A each (10.5 watts)
- Aluminum housing and flange
- 10' 14AWG *3C power cord
- When specified, the Power Module is centered on the audience-side edge of the worksurface
- Worksurface cutout size: 5.65"W x 1.65"D
- ETL-certified

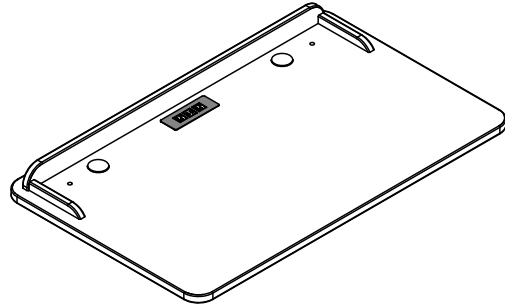

ORDER CODE 7 = EM Wireless Charging Pad

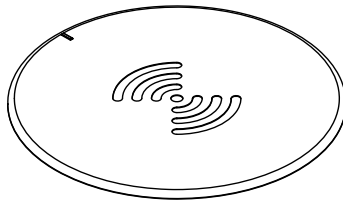

- Uses electromagnetic technology to charge Qi V1.2 compliant IC devices ("Qi" enabled)
- LED to confirm pairing / charging
- Security tab prevents theft
- Includes 3" round cutout
- UL-certified

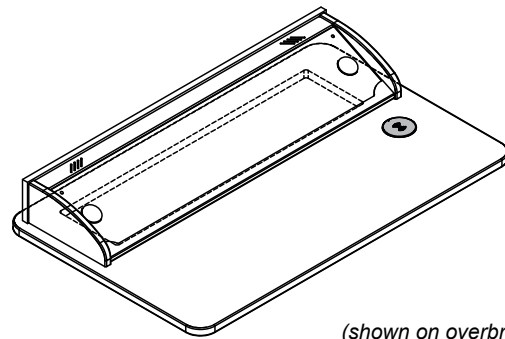
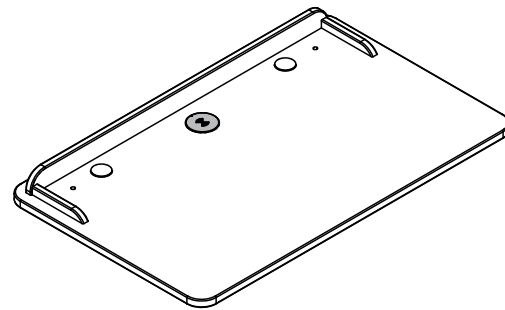

(shown on overbridge version)

ORDER CODE 4 = Power Module - Black & EM Wireless Charging Pad

ORDER CODE 5 = Power Module - Silver & EM Wireless Charging Pad

ORDER CODE 6 = Power Module - White & EM Wireless Charging Pad

(available on plain and surround worksurface only)

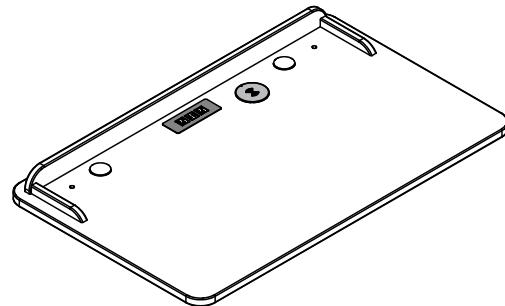

Custom / Additional Cutout Request

ORDER CODE 0 =	None
ORDER CODE 2 =	Yes - in Worksurface
ORDER CODE 3 =	Yes - in OB Panel

Director Lectern with surround
 (shown with optional keyboard tray)

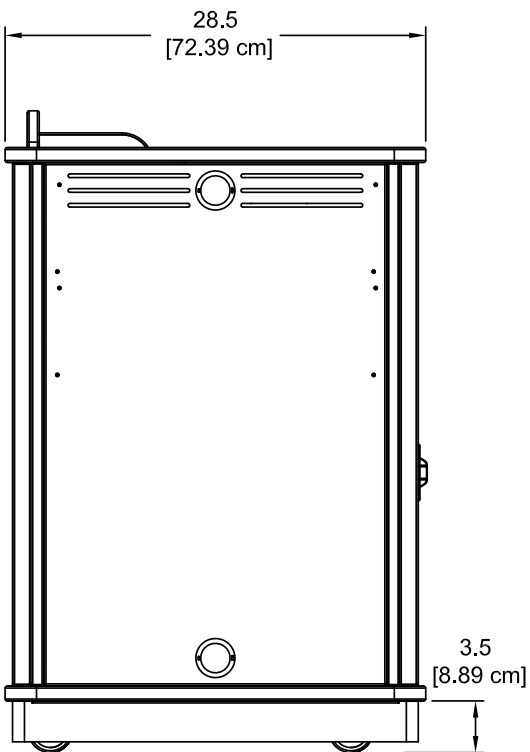
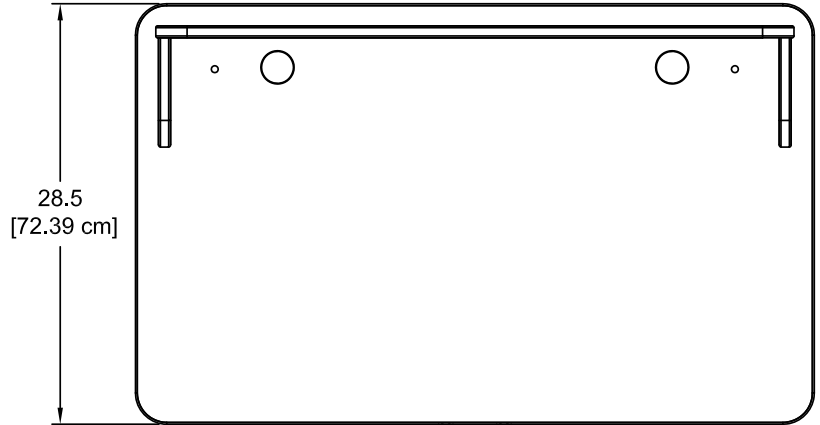
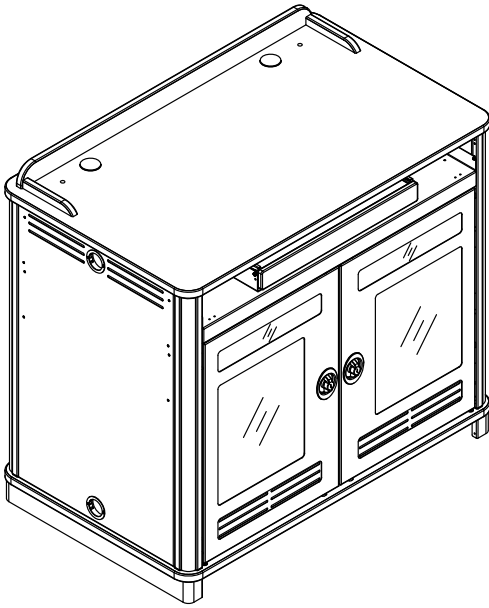

Metal side panel shown

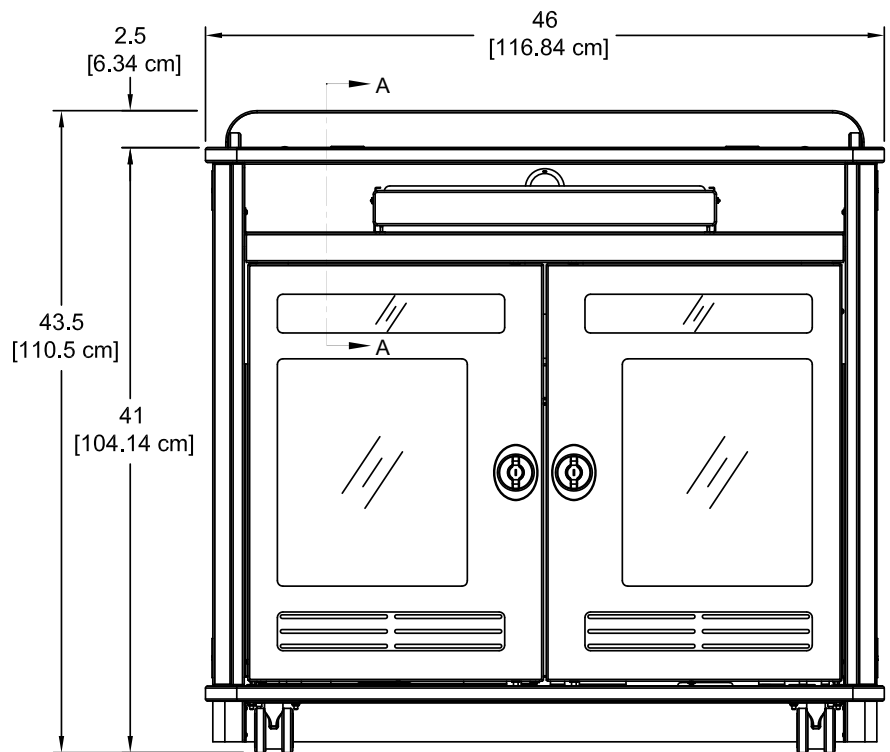

Top View
Surround worksurface
Max cutout area

Modified worksurface cutouts should be reviewed by Spectrum to ensure clearance of brackets, keyboard tray slides, or other objects under the worksurface.

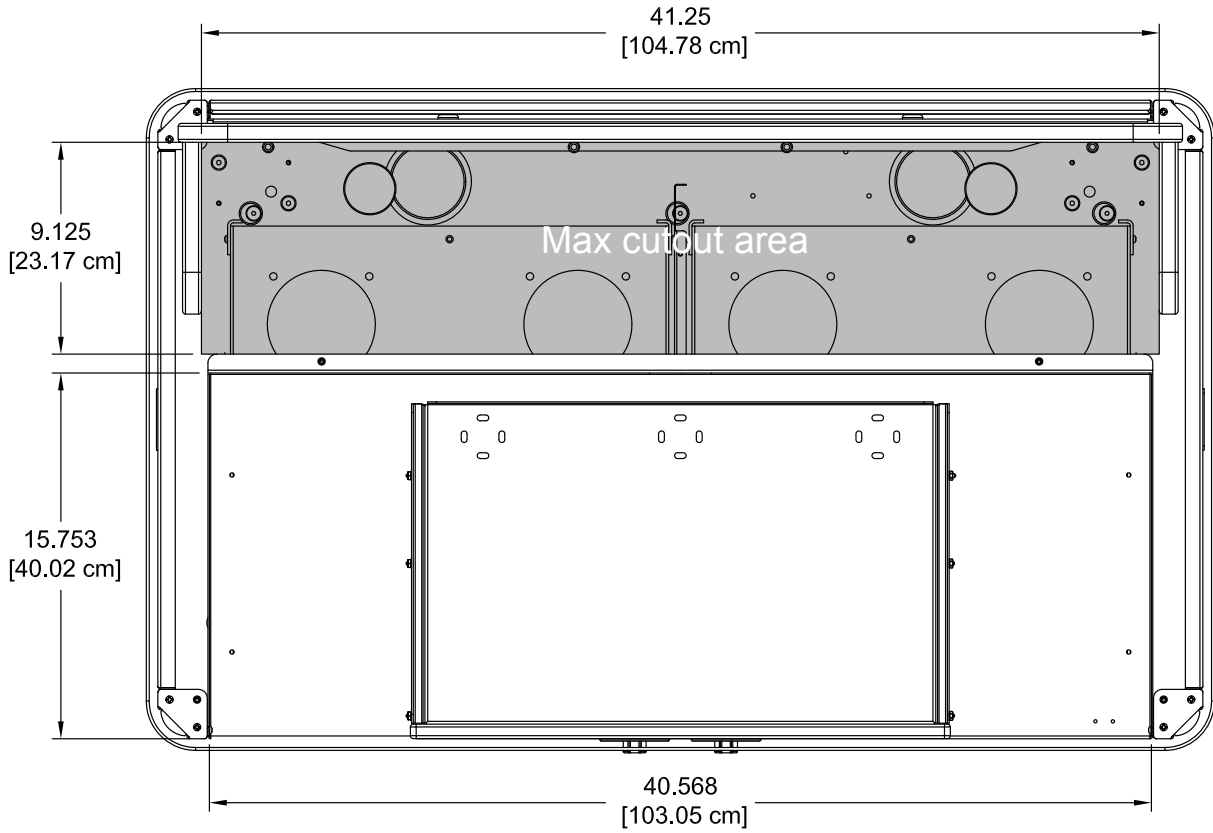

Section View A-A
Surround worksurface

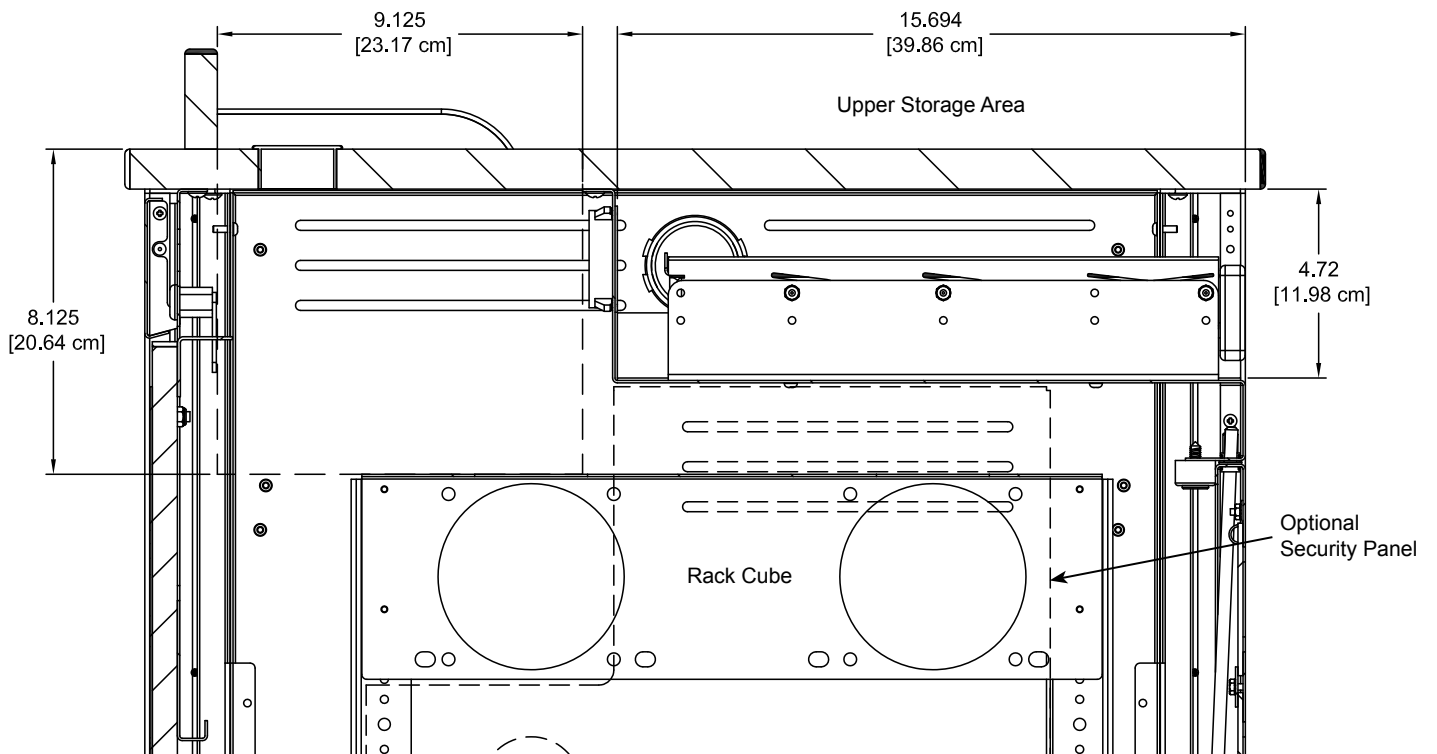

Director Lectern
with Overbridge Control Console
(shown with optional keyboard tray)

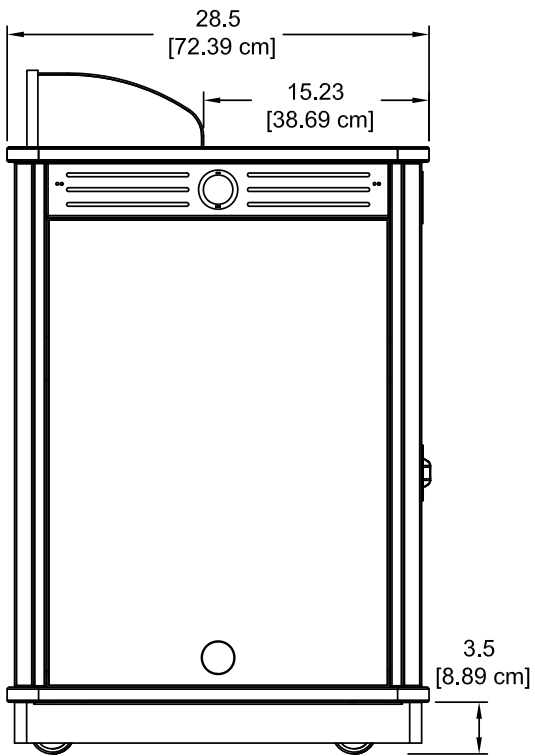
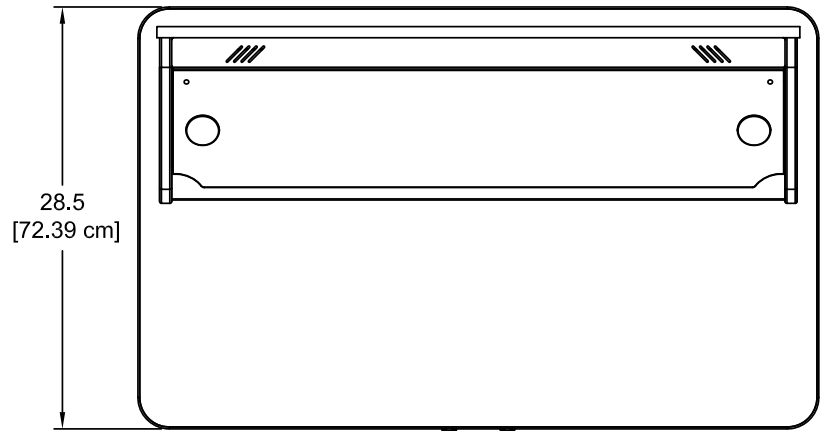
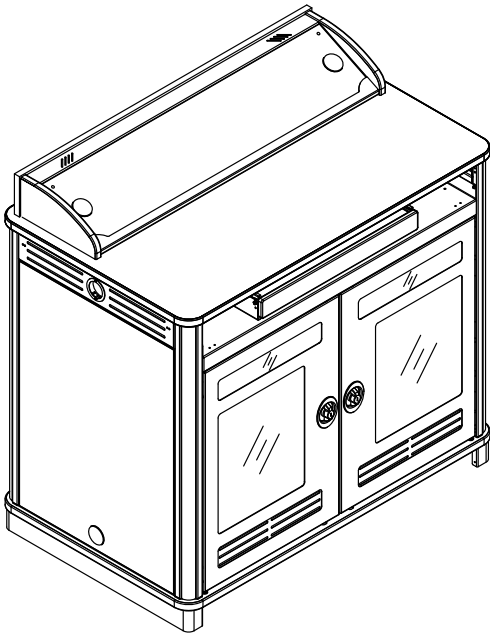

Laminate side panel shown

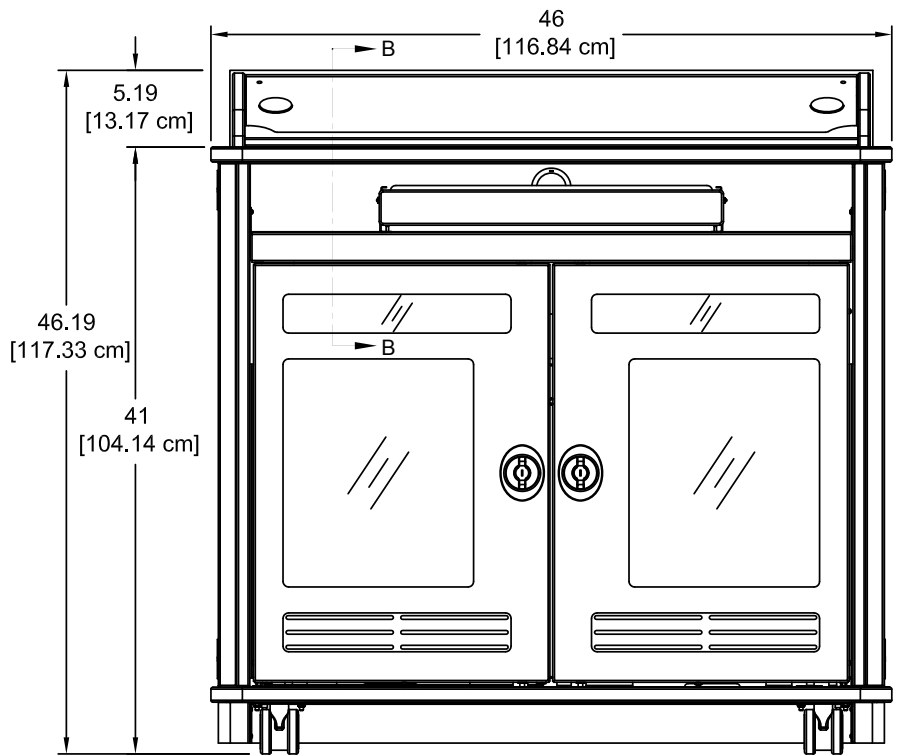

Director Lectern Overbridge Insert Panel Blank
(flat view)

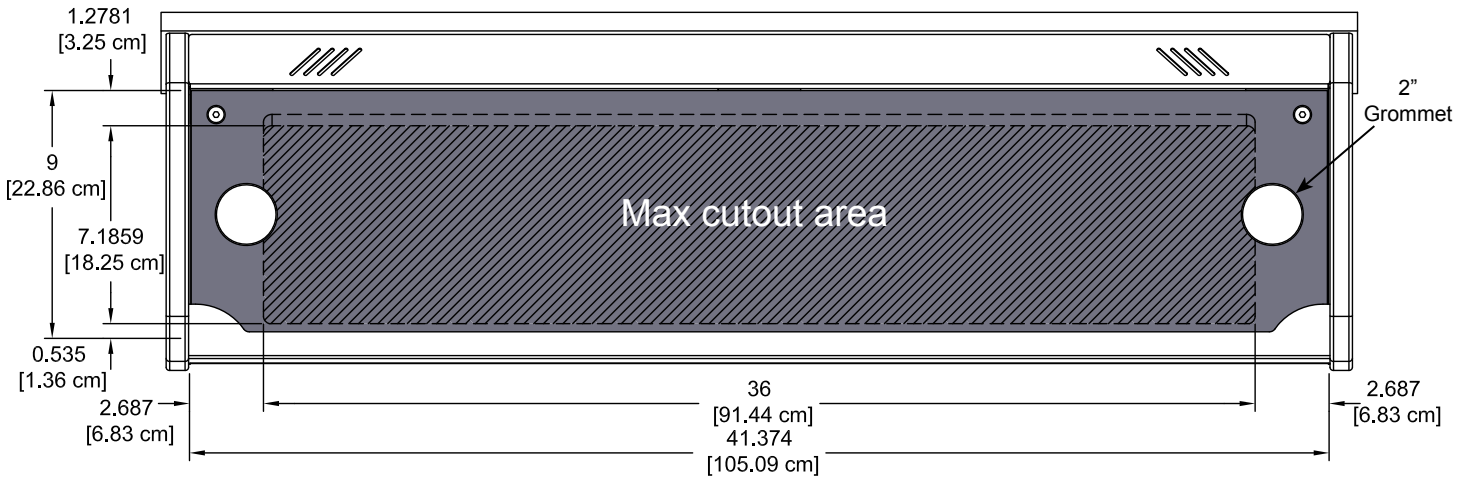

Overbridge
Section View B-B

Note: The Overbridge Control Console™ has been designed for many of the currently available controllers on the market, however, modified cutouts should be reviewed by Spectrum to ensure clearance of brackets, keyboard slides, or other objects under the worksurface.

Contact Spectrum to specify cutout size(s) and location(s).

Cutouts can be made in the blank insert panel by the customer after the lectern has been purchased, but are only recommended within the cutout area shown.

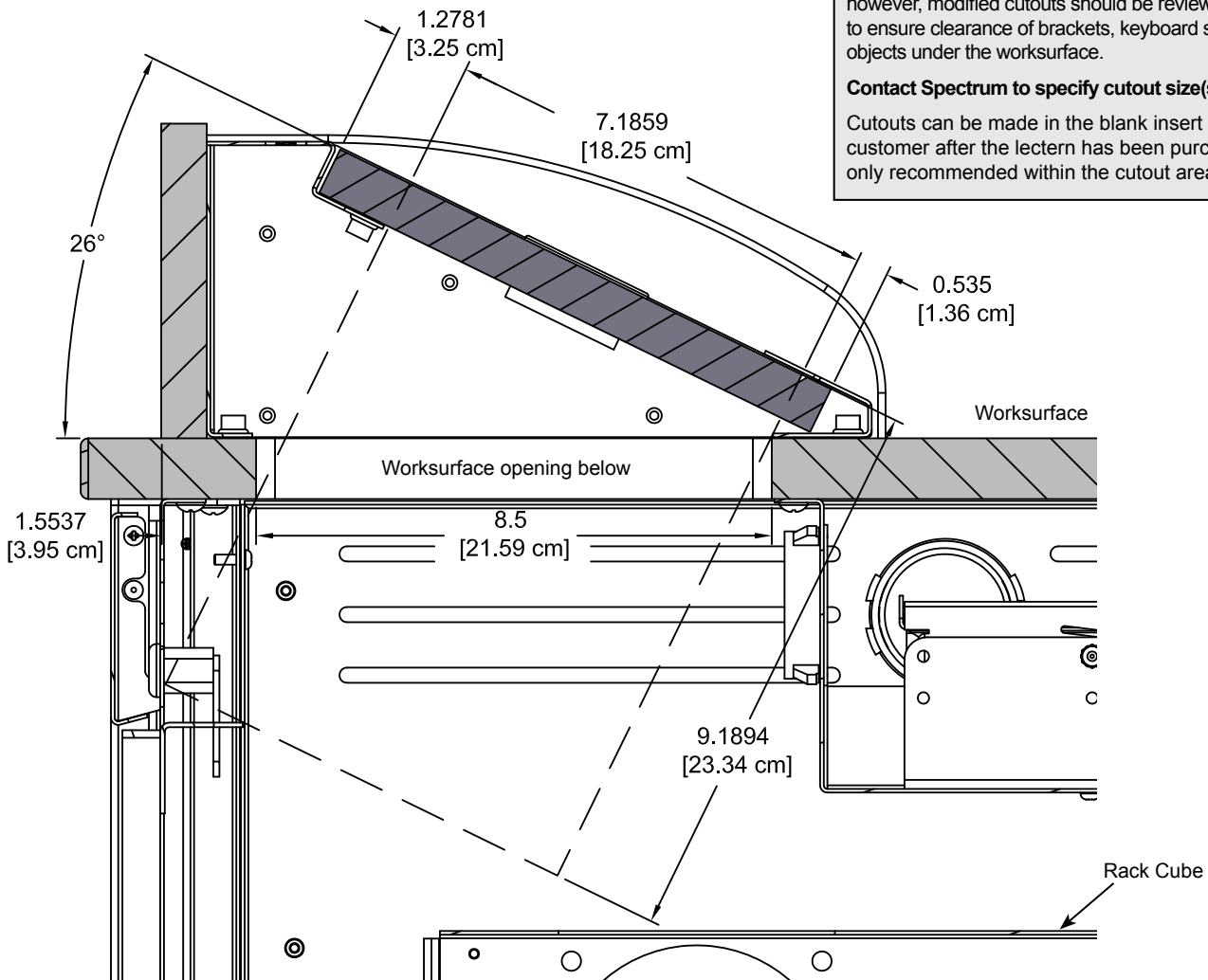

Optional 13RU Rack Cube

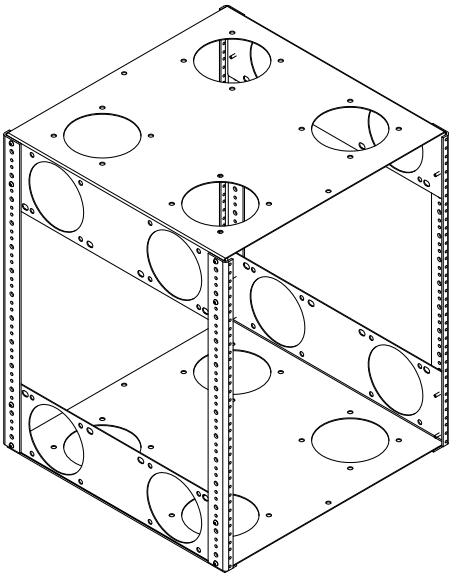

Note: One or two rack cubes can be installed in the Director Lectern.

(Maximum component depth available)

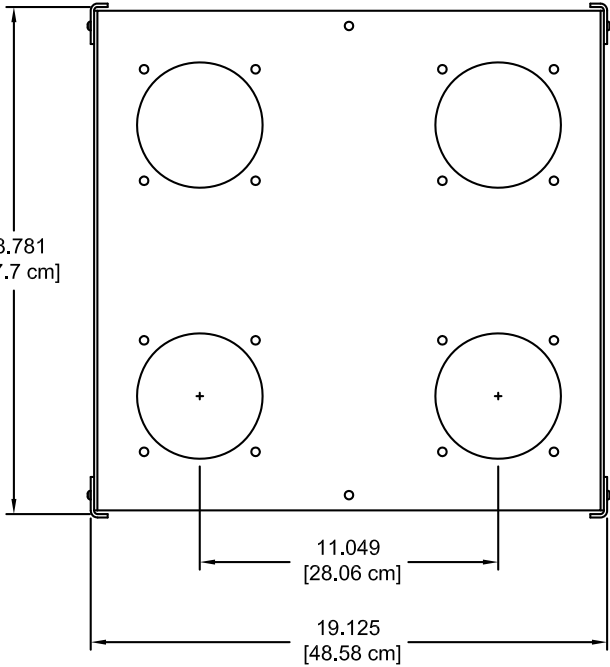

(Overall depth)

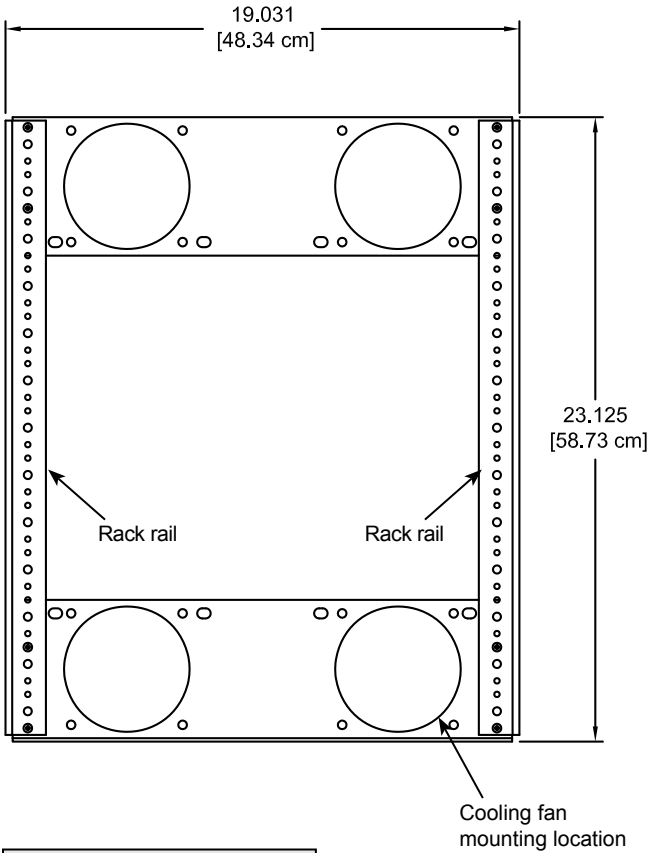

Note: Check the dimensions of all equipment before installation.

revised 8/2/19

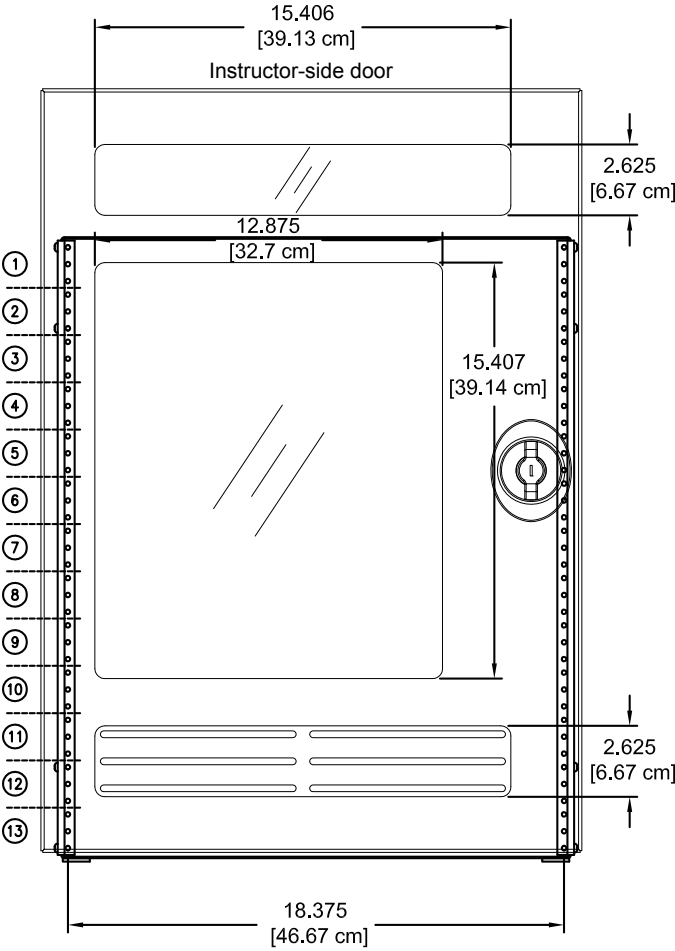

Accessories (Customer-installed when purchased separately.)

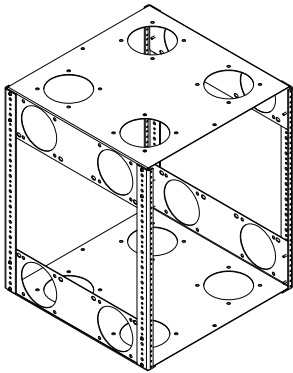

13RU

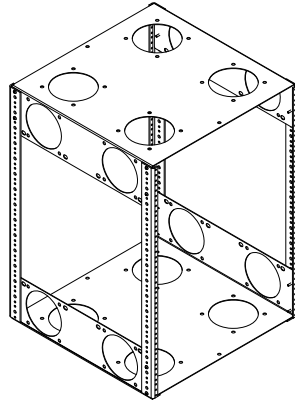

15RU

The 55384 15RU Rack cube is compatible with the Director Lectern if the number of rack units needs to be maximized.

15RU Rack Cube - 55384

13RU Rack Cube - 55381

- Provides the ability to integrate equipment remotely before installation into the lectern
- The Director Lectern can accommodate up to two rack cubes
- Polyethylene slides on bottom for easy removal
- Clearance for optional base-mounted cord reel
- Can be secured to base panel
- Cooling fan compatible
- Color: black

Rack rail:	15RU front and rear 13RU front and rear
Dimensions 15RU Cube:	19.125"W [48.58 cm] x 19.031"D [48.34 cm] x 26.625"H [67.63 cm]
Dimensions 13RU Cube:	19.125"W [48.58 cm] x 19.031"D [48.34 cm] x 23.125"H [58.74 cm]
Cooling fan mounts:	Compatible with most 4.7" fans with 4.13" mounting hole spacing (12 mounting locations available)
Unit weight:	21 lb [9.5 kg] 15RU Cube 20 lb [9 kg] 13RU Cube
Shipping weight:	23 lb [10.4 kg] 15RU Cube 20 lb [9.1 kg] 13RU Cube

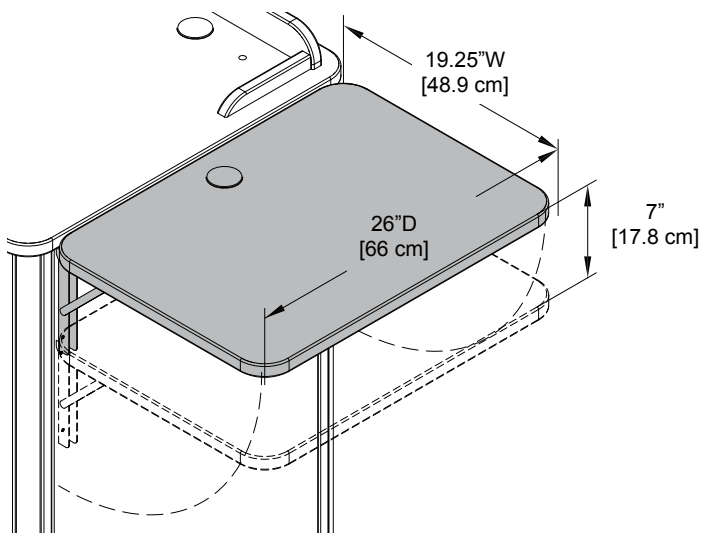

Flip-Up Shelf - 55269

- Shelf hinges lock into place in the upright position
- Includes 2" grommet
- Available in White Chalk Dry Erase laminate
- Two height positions available

Weight capacity:	35 lb [15.9 kg]
Dimensions:	19.25"W [48.9 cm] x 26"D [66 cm] x 1"H [2.54 cm]
Height positions available:	41"H [104.1 cm] (level with worksurface) 34"H [86.4 cm]
Shipping weight:	21 lb (9.5 kg)

Note: Power and communication wiring for document cameras, laptop computers, and/or projectors placed on the flip-up shelf should be routed on top of the audience-side of the shelf. Use of the shelf grommet hole for wiring will result in pinching of the cords when the shelf is folded.

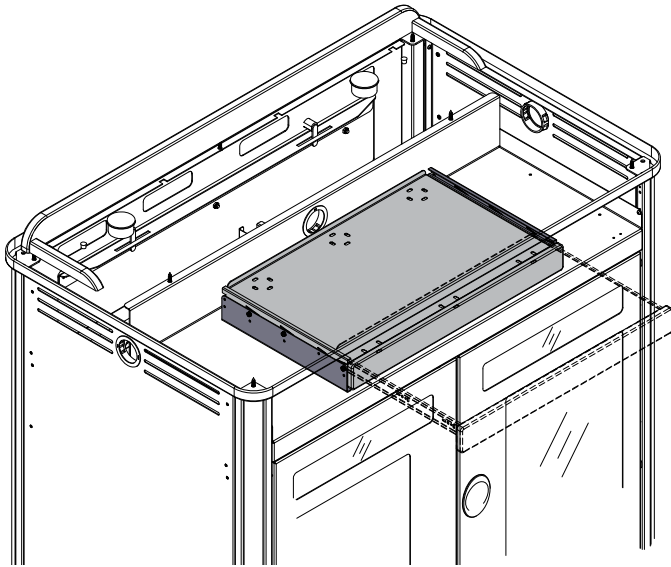

Keyboard Tray - 55386

- Installed centered using pre-drilled mounting holes under the work surface
- Can be used as a keyboard tray or flipped and used as a storage drawer
- Wire management slots in tray

Dimensions:	22"W [55.9 cm] x 13.8"D [35 cm] x 2.1"H [5.3 cm]
Slides:	14" [35.6 cm] full-extension
Weight capacity:	25 lb [11.4 kg]
Shipping weight:	12 lb [5.4 kg]

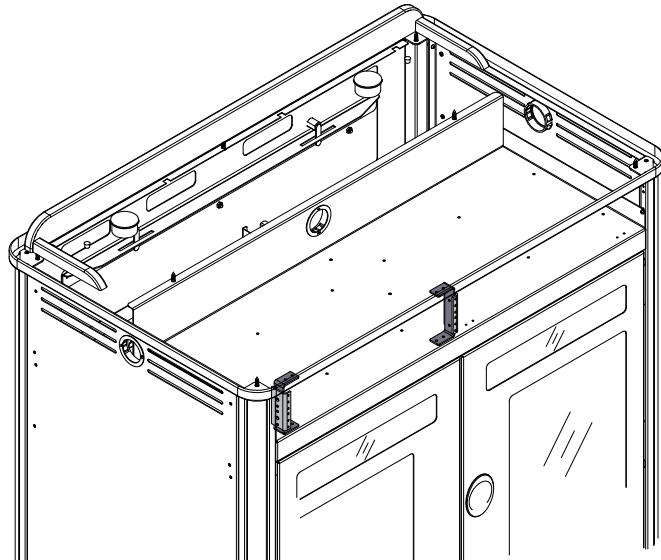

2RU Rack Rail Kit - 55113

- Adds an additional 2RU to lectern
- **Not compatible with keyboard tray (Keyboard Tray needs to be removed)**
- The Media Director Lectern can accommodate up to two rack rail kits
- Installed under work surface on left, or right side

Rack Units:	2RU
Shipping weight:	1 lb (.5 kg)



Customized Logo Panel - 55199

- Attaches to audience-side of lectern
- Available with black, white, or matching laminate backer
- To get panel customized-contact Spectrum for details
- New logos require a first time logo charge

Dimensions:	30"W [76.2 cm] x 12"H [30.48 cm]
Available logo area:	28"W [71.1 cm] x 10"H [25.41 cm]
Shipping weight:	8 lb [3.6 kg]

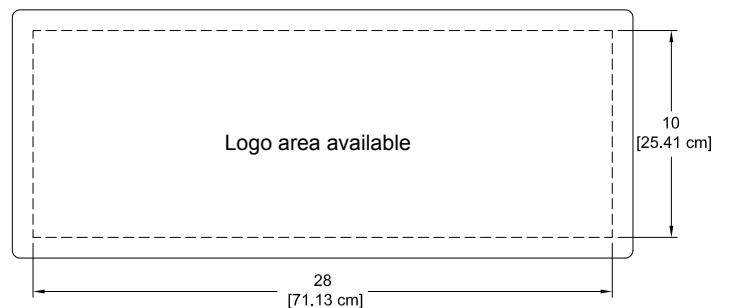

Insert panels are available to customers needing a replacement panel or different cutouts for technology upgrades.

Overbridge Insert Panel-XL - 96510

- Panel for overbridge version only (overbridge not available separately)
- Contact Spectrum to specify cutout size(s) and position(s)
- Includes two 2" [5.08 cm] grommets with covers

Dimensions:	41.25"W [104.8 cm] x 9"D [22.9 cm] x .79"H [2 cm]
Unit weight:	N/A
Shipping weight:	9 lb [4.1 kg]

Two-piece Overbridge Insert Panel-XL - 96514

- Split panel for overbridge version only
- Contact Spectrum to specify cutout size(s) and position(s)
- Includes 2" [5.08 cm] grommets with covers
- Customer-installed

Dimensions:	20.625"W [52.39 cm] x 9"D [22.86 cm] x .79"H [2 cm]
Unit weight:	N/A
Shipping weight:	9 lb [4.1 kg]

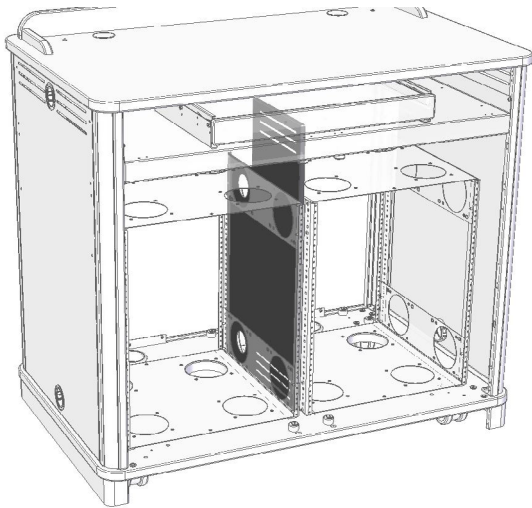
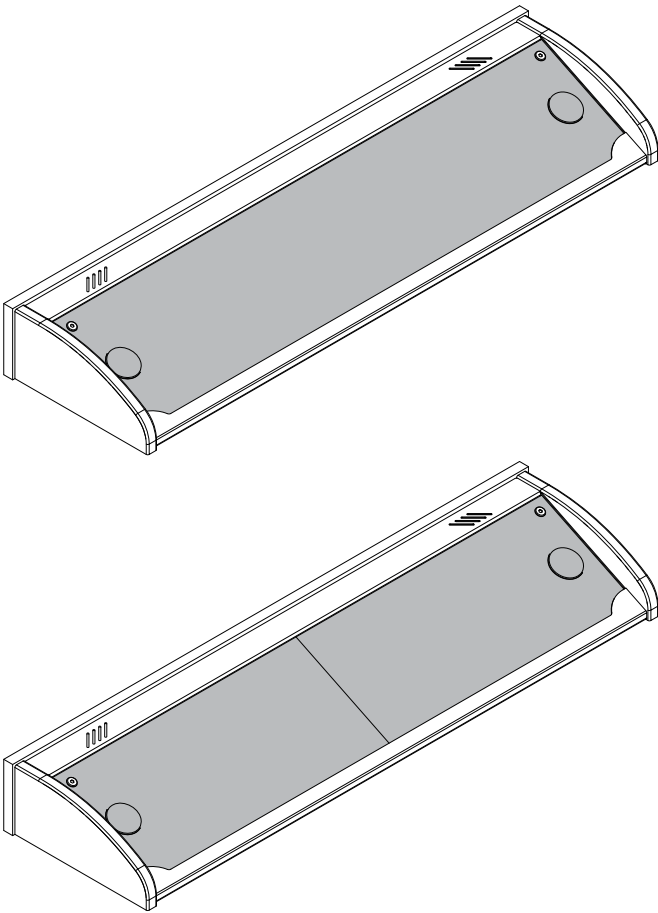

Security Panel - 55383

- Installs between rack cubes to provide security
- Includes ventilation slots and grommet pass-throughs
- Notched corner for center-mounted worksurface or overbridge components
- Shipping weight: 8 lb [3.6 kg]

Toe Kick Kit - 55382

- Attaches to floor and lectern when mobility is not necessary or desired (floor fasteners not included)
- Conceals casters
- Includes access panel
- Shipping weight: 8 lb [3.6 kg]

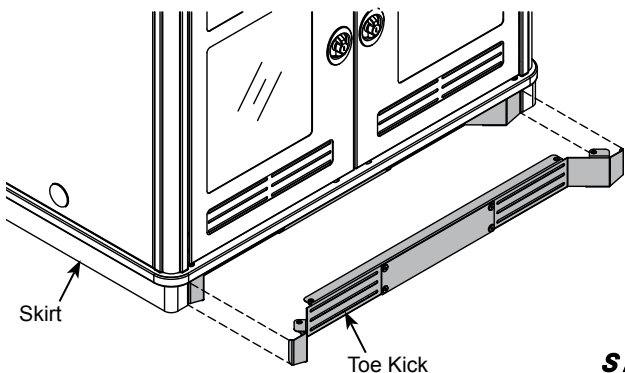

revised 8/2/19

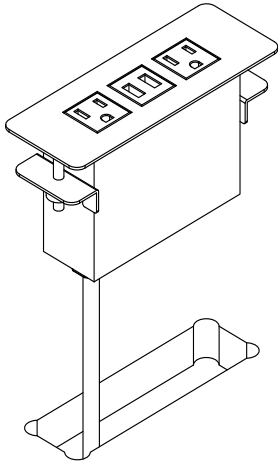

Power Module - 99058

- (2) AC power receptacles
- (2) USB charge ports
- Aluminum housing and flange
- Thumbscrew clamps
- Requires worksurface cutout
- ETL-certified
- Available in black, silver, or white
- Customer-installed

Cutout required:	5.65"W [14.35 cm] x 1.65"D [4.19 cm]
Power cord:	10' [305 cm] 14AWG *3C power cord
Power receptacles:	125V, 60hz, 15A tamper-resistant
USB charging ports:	2.1A (10.5W) (not data-compatible)
Dimensions:	6.38"W [16.2 cm] x 2.36"D [6 cm] x 3.54"H [9 cm]
Unit weight:	2 lb [.9 kg]
Shipping weight:	2.35 lb [1 kg]

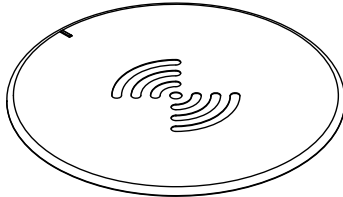

EM Wireless Charging Pad - 99057

- Uses electromagnetic technology to charge Qi V1.2 compliant IC devices ("Qi" enabled)
- LED to confirm pairing / charging
- Security tab prevents theft
- Requires 3" round cutout to be made by customer
- UL-certified

Cutout required:	3" dia (by customer)
Input:	DC 5V (with included DC5V.2A power adapter)
Output:	5W max (with included DC5V.2A power adapter)
Power cord:	8' [244 cm] with DC jack
Dimensions:	3.5" dia [8.9 cm] x 1.125"H [2.9 cm]
Shipping weight:	1 lb [.45 kg]

Note: The unit requires a 7" diameter of clearance to work with Qi-enabled phones placed in any orientation. The 3" dia cutout should be located on the worksurface at least 3.5" from any edge.

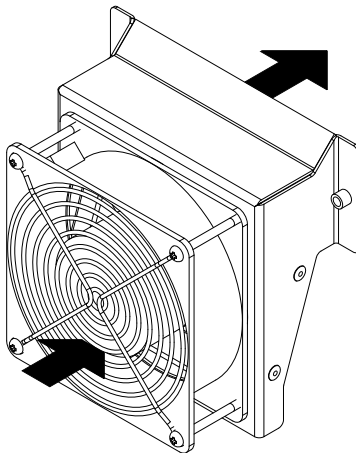

Cooling Fan for Media Manager Series Lecterns - 99051

- Exhausts hot air from inside lectern
- Installs inside lectern at top of rack cabinet
- Mounts to side panel vent slots with two screws
- Customer-installed

Electric Fan:	• Voltage: 115VAC (single phase)	• Noise: 28 dB
	• Power: 5.5W	• Air flow: 49.4 CFM (1.40m ³ /min)
	• Current: .08A	• Frame material: Aluminum
	• 1450 RPM	• Blade material: Polycarbonate, Fiberglass reinforced
	• Dimensions: 119 mm x 119 mm	
	• Ball Bearing	
Power cord:	18ga, 48" nominal length, 6A 125V~ (2 prong plug)	
Mounting bracket	• 16-gauge steel	
	• Black powder coat	
	• Mounting screws included	
Unit weight:	2.3 lb [1.05 kg]	
Shipping weight:	3 lb [1.36 kg]	

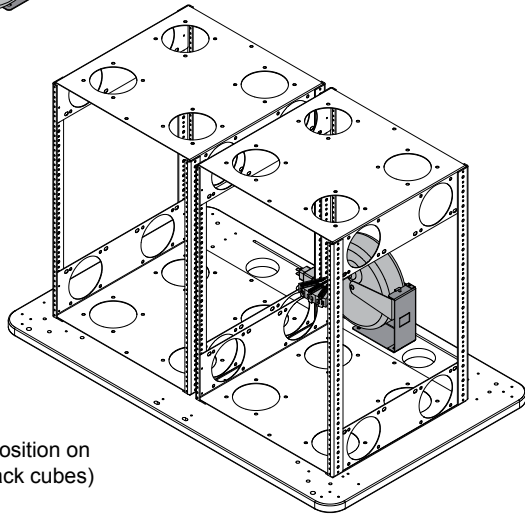
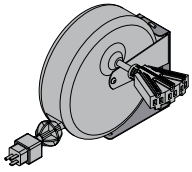

(Available position on base with rack cubes)

Universal Cord Reel Kit - 99037

- Includes universal mounting bracket
- Mounts inside lectern to base panel
- Adjustable ball stop and releasable cord-locking ratchet holds the cord at any length up to 15'
- cUL listed

Power cord:	15' nominal, 12 AWG retractable power cord
Power receptacles:	<ul style="list-style-type: none"> • Molded 3-prong male plug with 15A breaker and reset button • Tri-tap (3-outlet) receptacle
Universal mounting bracket:	<ul style="list-style-type: none"> • 16-gauge steel • Black powder coat • Includes mounting screws
Unit weight:	10 lb [4.5 kg]
Shipping weight:	10.8 lb [4.9 kg]

The cord reel is intended to provide temporary access to electrical outlets for Spectrum mobile lecterns. Check local electrical codes prior to installation.



Flat Panel Monitor Arm

95512 - "Light-Duty" for monitors weighing 2-13 lb [.9-5.9 kg]

95522 - "Medium-Duty" for monitors weighing 7.5-25 lb [2.5-11.4 kg]

95509 - "Heavy-Duty" for monitors weighing 12-31 lb [5.4-14 kg]

- Six mounting options (clamp, thru-desk, wall, grommet hole, side bolt, reverse wall)
- Compatible with all VESA® monitors – includes 75mm and 100mm VESA® adapters
- Cable management concealed in arm

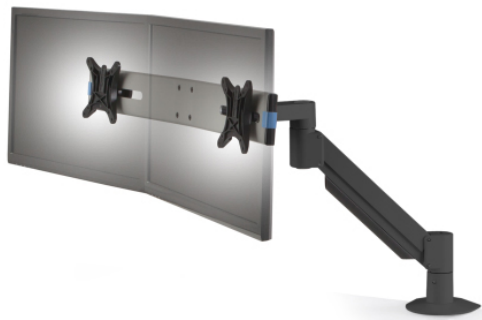

Dual Flat Panel Monitor Arm - 95533

- Weight range: 3.5-13 lb [1.6-5.9 kg] per monitor
- Six mounting options (clamp, thru-desk, wall, grommet hole, side bolt, reverse wall)
- Compatible with all VESA® monitors – includes 75mm and 100mm VESA® adapters
- Cable management concealed in arm

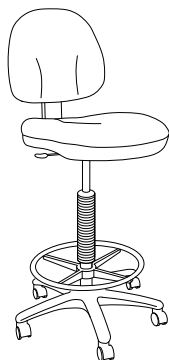

Adjustable Drafting Stool - 38202

- 40-52" height-adjustment via pneumatic cylinder
- 360° swivel
- Tilting backrest
- 18" diameter fixed foot ring
- 5-star base

Rack-mount Accessories

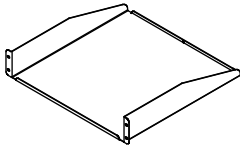

Cantilever Shelf - 2RU - 97504

- 16ga steel
- Shelf: 17.5"W [44.45 cm] x 18"D [45.7 cm] x 3.5"H [8.89 cm]
- Weight capacity: 50 lb [22.7 kg]
- Shipping weight: 8.1 lb [3.7 kg]

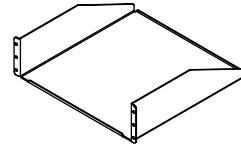

Cantilever Shelf - 3RU - 97502

- 16ga steel
- Shelf: 17.5"W [44.45 cm] x 18"D [45.7 cm] x 5.25"H [13.33 cm]
- Weight capacity: 80 lb [36.3 kg]
- Shipping weight: 9.2 lb [4.2 kg]

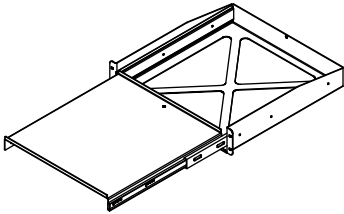

Pull-Out Shelf - 2RU - 97505

- 16ga steel
- 17.09"W [43.42 cm] x 18.12"D [46.03 cm] x 3.5"H [8.89 cm]
- Weight capacity: 50 lb [22.7 kg]
- Shipping weight: 15.6 lb [7.1 kg]

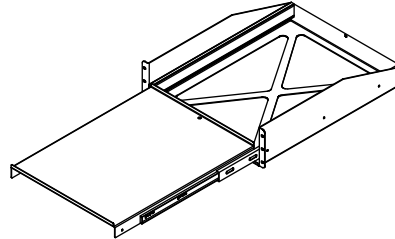

Pull-Out Shelf - 3RU - 97503

- 16ga steel
- 17.09"W [43.42 cm] x 22.11"D [56.14 cm] x 5.25"H [13.33 cm]
- Weight capacity: 80 lb [36.3 kg]
- Shipping weight: 18.5 lb [8.4 kg]

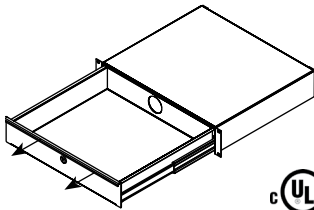

Locking Drawer - 2RU - 97523

- 16ga steel
- Drawer: 15.97"W [40.56 cm] x 14.56"D [36.98 cm] x 3"H [7.63 cm]
- Weight capacity: 50 lb [22.7 kg]
- Shipping weight: 15.85 lb [7.2 kg]

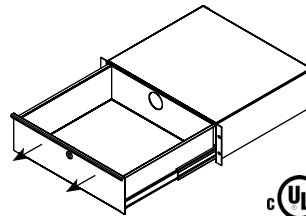

Locking Drawer - 3RU - 97522

- 16ga steel
- Drawer: 15.97"W [40.56 cm] x 14.56"D [36.98 cm] x 5.25"H [13.33 cm]
- Weight capacity: 50 lb [22.7 kg]
- Shipping weight: 18.5 lb [8.4 kg]

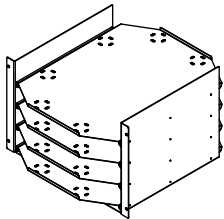

LT-4 Laptop Storage Unit - 7RU - 97517

- Holds four full-size laptops
- 16ga & 20ga steel
- 18.75"W [47.94 cm] x 20.5"D [52.11 cm] x 12.25"H [31.11 cm]
- Shipping weight: 30 lb [13.6 kg]

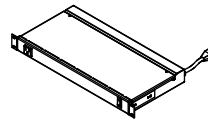

9-Outlet Power Strip - 1RU - 99021

- 8 outlets rear (breaker-protected)
- 1 convenience outlet front
- 115VAC, 60 Hz, 15 amps max
- 9' power cord
- Front LED power switch
- Enhanced surge protection
- ETL-listed, UL-listed
- 19"W [48.27 cm] x 9.25"D [23.5 cm] x 1.74"H [4.41 cm]
- Shipping weight: 8.7 lb [3.9 kg]

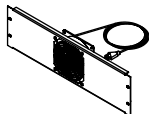

Single Fan - 3RU - 97507

- 50 cfm
- 120V~50/60 Hz, 15/13W
- RoHS
- 19"W [48.27 cm] x 1.56"D [3.97 cm] x 5.25"H [13.33 cm]
- Shipping weight: 3.78 lb [1.7 kg]

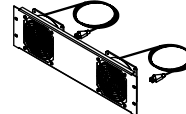

Double Fan - 3RU - 97506

- 100 cfm
- 120V~50/60 Hz, 15/13W
- RoHS
- 19"W [48.27 cm] x 1.56"D [3.97 cm] x 5.25"H [13.33 cm]
- Shipping weight: 5.47 lb [2.5 kg]

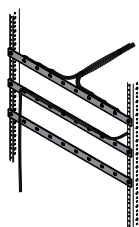

Wire Lace Kit - 95517

- Provides wire management
- Mounts to standard rack rails
- Includes (3) lace straps and mounting screws
- Includes (12) 5.5" zip ties
- Shipping weight: 1.25 lb [.57 kg]

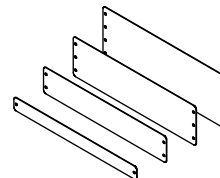

Rack-Mount Blanks

1RU - 97510 **3RU - 97512**
2RU - 97511 **4RU - 97513**

- Fills rack spaces where components are not needed
- 16 ga steel
- Shipping weight: <1 lb [.45 kg]

See spectrumfurniture.com for the latest accessories and detailed warranty information.

Warranty

We will make it right for you!

Spectrum is committed to provide complete customer satisfaction. Each of our products is manufactured from the best materials available and each product is stringently monitored throughout the production process through our Quality Management System.

We expressly warrant that Spectrum products will be of good quality and workmanship and free from defect for the period set out in the warranty table below from the date of delivery. This warranty shall not apply to defects or damage resulting from normal wear and tear, misuse, or unintended use, failure to follow instructions related to the product's installation or intended use, abuse, neglect, improper care, modification or repair not authorized by Spectrum, or any other cause outside the control of Spectrum. Spectrum will, at its sole option, either repair or replace the defective product.

This warranty is exclusive; no other warranty, written or oral, is expressed or implied. This warranty is given by Spectrum to Buyer or Buyer third party end user and to no other person or legal entity. No Spectrum dealer, distributor, partner, reseller, agent or employee is authorized to make any modification or addition to this warranty.

NOTWITHSTANDING ANYTHING TO THE CONTRARY, SPECTRUM WILL NOT UNDER ANY CIRCUMSTANCES BE LIABLE FOR INDIRECT OR LIQUIDATED DAMAGES, INCLUDING CONSEQUENTIAL, INCIDENTAL AND SPECIAL DAMAGES. IN NO EVENT SHALL SPECTRUM'S LIABILITY, WHETHER UNDER CONTRACT OR WARRANTY, IN TORT OR OTHERWISE, EXCEED THE PURCHASE PRICE RECEIVED BY SPECTRUM FOR THE PRODUCT AT ISSUE AND "RECALL ACTION" EXPENSES. SPECTRUM SHALL NOT BE SUBJECT TO ANY OTHER OBLIGATIONS OR LIABILITIES, WHETHER ARISING OUT OF BREACH OF CONTRACT, WARRANTY, TORT (INCLUDING NEGLIGENCE AND STRICT LIABILITY) OR OTHER THEORIES OF LAW, WITH RESPECT TO PRODUCTS SOLD OR SERVICES RENDERED BY SPECTRUM, OR ANY UNDERTAKINGS, ACTS OR OMISSIONS RELATING THERETO.

Our Customer Service Department is ready to provide immediate attention to any questions, comments or concerns. They are available to answer your calls Monday through Friday from 7 am to 5 pm CST. In addition your product comments or concerns are welcome via e-mail at: spectrum@spectrumfurniture.com.

Warranty Table

Item	Warranty Period
Desk, table, cart and lectern chassis	10 Years
Electrical	2 Years
Flat panel monitor arms / gas spring / general parts	2 Years
Adjustable crank / electric legs and accessories	2 Years
Flat panel desk gas spring cylinders	2 Years
Height adjustable columns, lifts & accessories	2 Years
Casters & wheels	2 Years
Keyboard, mouse, trays	2 Years
Locks & keys	2 Years
Tubs, totes and other accessories	1 Year
Chairs Structural components, including gas cylinders, wood, metal and plastic parts (i.e., chair frames, bases and control handles)	7 Years
Consumable items (i.e., casters, glides, etc.)	5 Years
In-stock upholstery	5 Years
Customer supplied material	No Warranty



Spectrum Industries Inc.
is Certified ISO 9001:2015