

Technical Specifications

55258

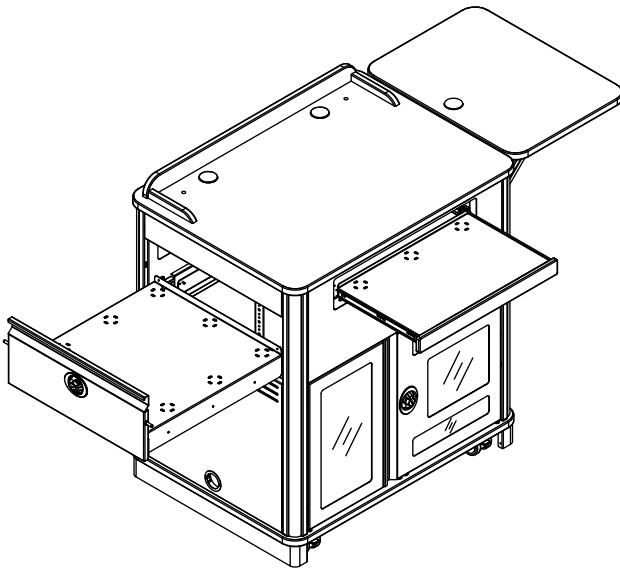

Media Manager Elite with surround, left drawer, rack cube installed on right, flip-up shelf on right

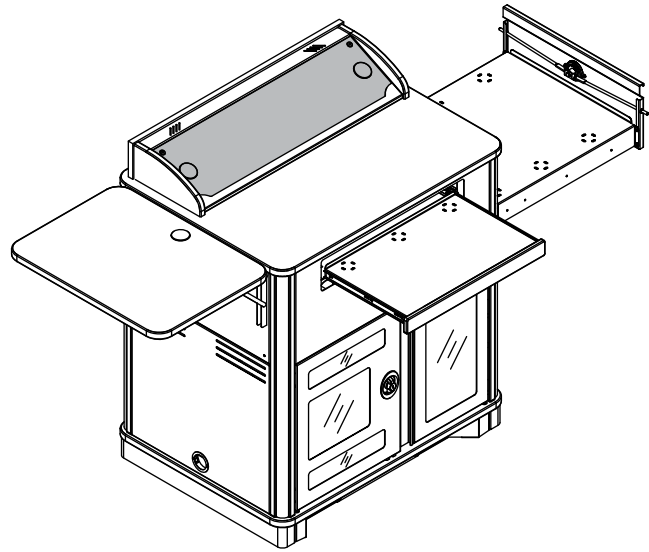

Media Manager Elite with overbridge, right drawer, rack cube installed on left, and toe kick, flip-up shelf on left

The Media Manager Elite is Spectrum's most popular lectern for college and university classrooms. It is the most practical lectern for the media-intensive classroom featuring a steel chassis with integral ventilation, a removable rack cube with front and rear access, and the largest locking document camera drawer in the industry. The Media Manager Elite is available in either left or right-hand drawer configurations. It is also easily customized with an Over-bridge Control Console for controllers, and laser cut logos to match any institution.

Features and Benefits

- Scratch and impact-resistant high-pressure laminate top provides a durable, useful worksurface
- Surround on worksurface provides privacy and styling
- Large locking pull-out drawer featuring inboard-mounted slides (200 lb rating) and wiring slots, provides secure document camera storage and a wrist-friendly writing surface (can be ordered on the left or right side)
- Pull-out keyboard tray with wiring slots can be used as a keyboard tray or storage drawer (supports large keyboards up to 19" wide with mouse)
- Overbridge version with blank panel allows custom cutouts and installation of electronics (overbridge version only)
- Worksurface grommet holes and cable grommets throughout lectern provide cable access
- Pre-drilled monitor arm mounting holes allow installation of a monitor arm (surround version only)
- 3" swivel Twin-Wheel (TW) casters provide mobility (2 locking)
- 2" grommet in each side panel provide cord access
- Cable grommets throughout provide cable access
- Wiring channel provides easy cable routing
- Integrated ventilation throughout lectern helps keep equipment cool
- Primary and secondary instructor side acrylic doors provide monitoring of internal equipment, security, and can be removed via quick-release to provide full access to rack equipment. Doors can be attached on the left or right side of the lectern with minimal re-assembly.
- Primary door has double-bolt keyed lock.
- Optional removable cube rack-rail mounting (12RU) simplifies installation for any equipment configuration, provides mounting capabilities for multiple cooling fans. Also provides the ability to integrate equipment remotely before being installed into the lectern at a later date.
- The rack cube provides the ability to integrate equipment remotely and can be installed into the left or right side of the lectern at a later date
- Removable audience-side panel provides access to internal equipment
- Optional toe kick panel with access panel is available when mobility is not necessary or required (requires wheels to be locked, can be anchored to floor) (customer-installed)
- Optional customizable logo panel simplifies adding or changing logos
- Optional flip-up shelf provides a convenient additional worksurface (mounts on side opposite document camera drawer)
- Durable powder coated steel chassis provides a long-lasting finish
- Warranted to be free of all defects in materials and workmanship for 10 years
- Designed and assembled in Chippewa Falls, WI, USA

Color Options

Available in Spectrum Expressions colors.
See spectrumfurniture.com for complete color information.

Ordering Instructions

Spectrum has designed this product to receive the useful options shown here.
To ensure your options are ordered correctly please call 1-800-235-1262.

Construction

- The worksurface is constructed from 1" thick NAF (No Added Formaldehyde) composite board with .030" high-pressure laminate on one face, and a balancing phenolic backer on the opposing face
- Metal components consist of 16-gauge steel
- Worksurface edges are covered with 3mm vinyl edgeband
- All metal components are finished with a scratch-resistant powder coat epoxy
- Solid wood corner trim
- Each Media Manager Elite Lectern is factory-assembled with casters, packaged, and shipped on its own skid. Customer-installed base skirt.

Specifications

Total lower internal area (nominal)	32.75"W [83.2 cm] x 26.12"D [66.4 cm] x 21.72"H [55.2 cm]	
CPU area (nominal)	12.4"W [31.5 cm] x 26.12"D [66.4 cm] x 21.72"H [55.2 cm]	
Keyboard tray	22"W [55.9 cm] x 13.75"D [35 cm] x 2"H [5.1 cm]	
Optional Rack cube	12RU	
3" Twin Wheel casters	Weight capacity 165 lb [74.9 kg] each	
Document Camera Drawer	<ul style="list-style-type: none"> • Internal dims: 23"W [58.4 cm] x 21.5"D [54.6 cm] x 6.22"H [15.8 cm] • 200 lb [90.8 kg] rated slides 	
Certifications / Compliance	<ul style="list-style-type: none"> • SCS Indoor Advantage Certified 	<ul style="list-style-type: none"> • Meets or exceeds applicable ANSI-BIFMA test standards
Unit weight (nominal)	261 lb [118.5 kg] (with surround) 266 lb [120.8 kg] (with overbridge)	
Shipping weight (nominal)	368.5 lb [167.3 kg]	

Specifications subject to change without notice

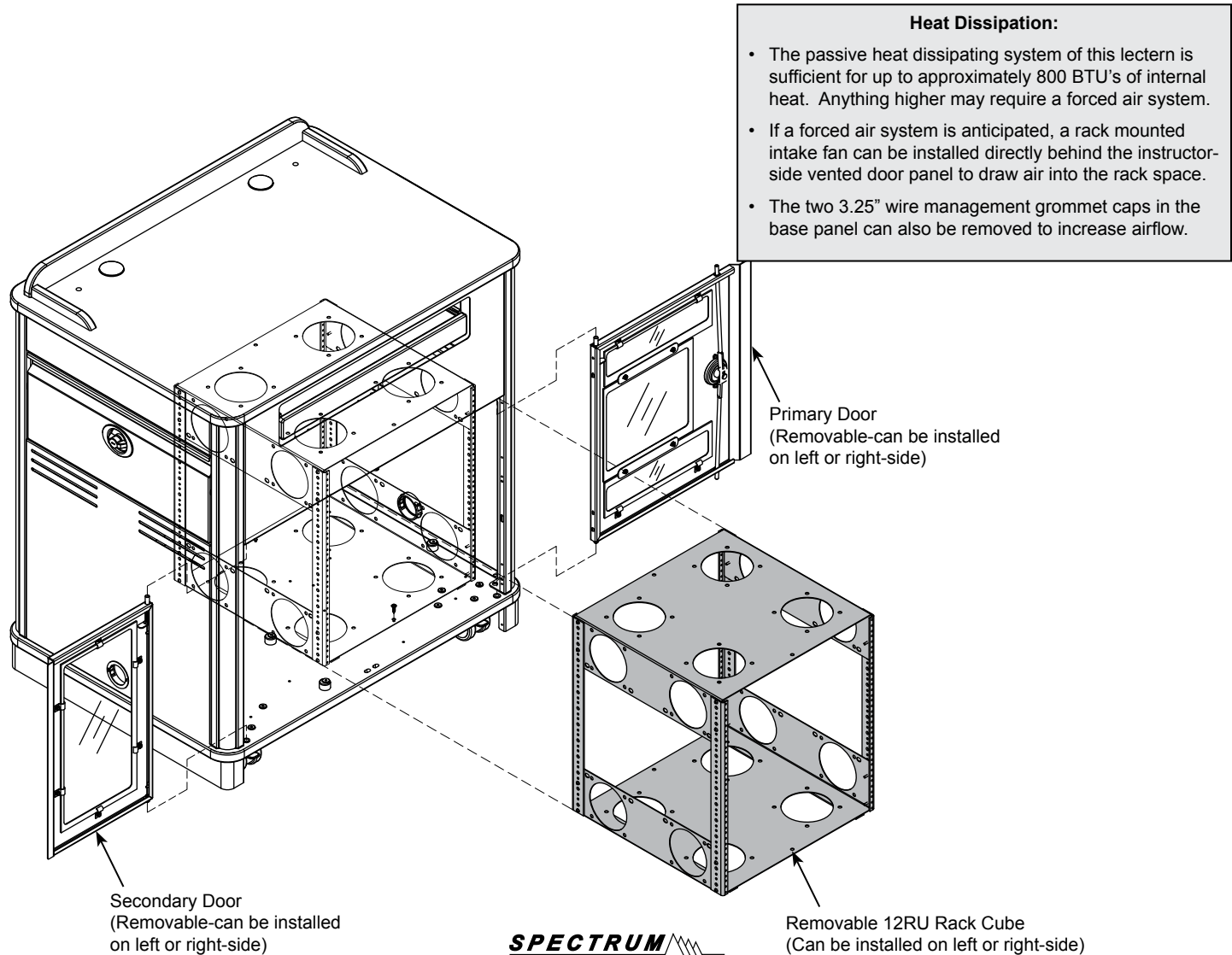

Audience-side view

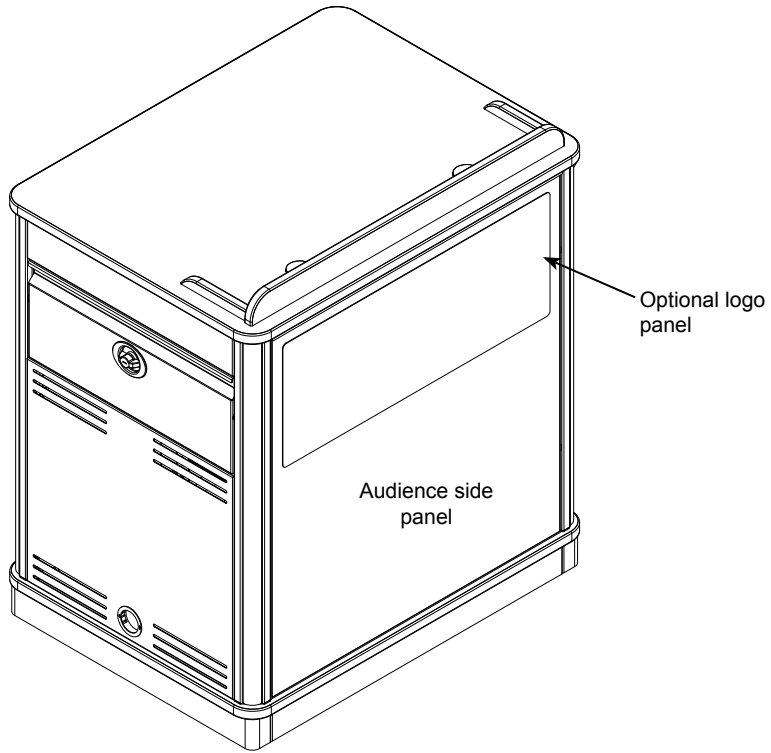

Bottom view

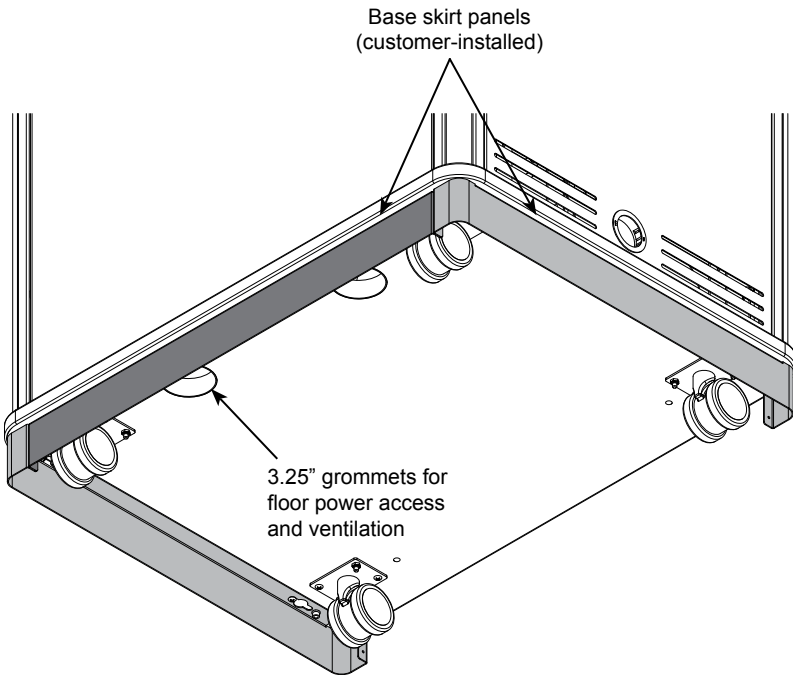

3" Twin-Wheel caster (TW)

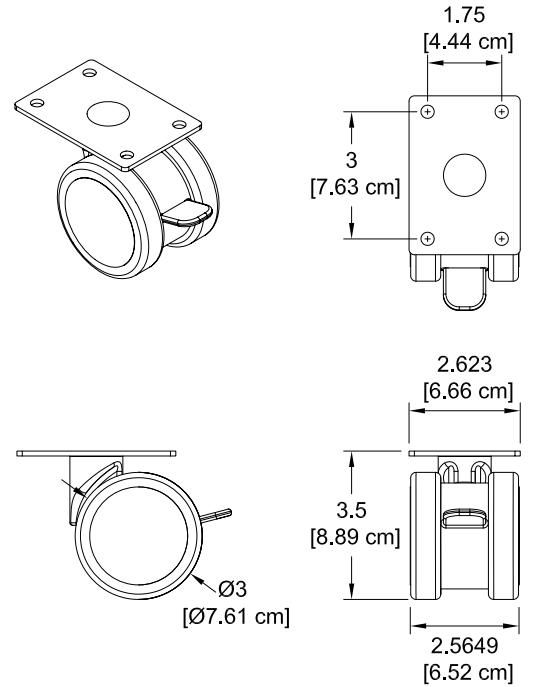

Pull-out Drawer

ORDER CODE L = Left

Instructor-side

Flip-up shelf here
(if equipped)

Instructor-side

ORDER CODE R = Right

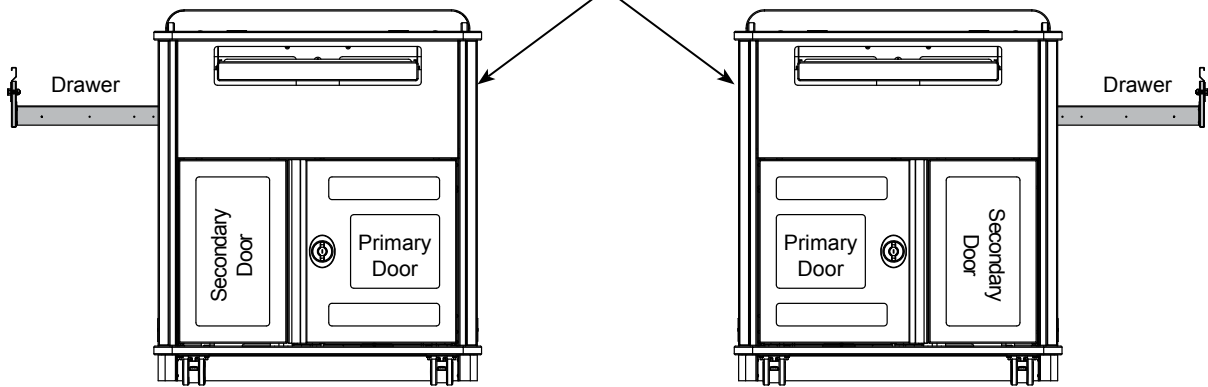

Lectern Style

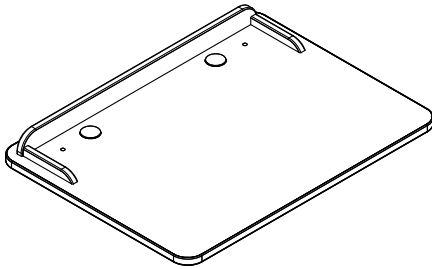

ORDER CODE S1 = Surround

- Surround
- Two 2" grommets (with covers)
- Two .375" holes (with plugs) for worksurface monitor arm mounting

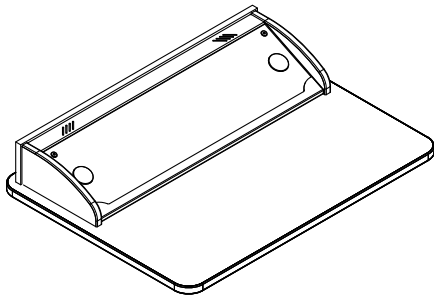

ORDER CODE B1 = Overbridge Control Console™

- Overbridge with blank insert panel for custom cutouts (see p.10 for dimensions). (Overbridge not available separately)
- Two 2" grommets (with covers)

Rack Cube

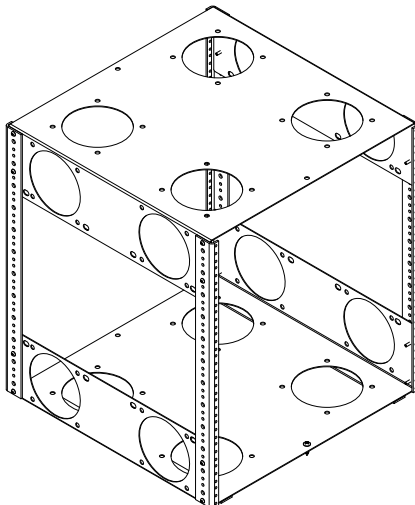

ORDER CODE 0 = None
ORDER CODE 4 = Yes

Note: If rack rail mounting is needed in the lectern, the rack cube must be specified. The lectern does not provide any rack-mount capabilities without the cube.

12RU Rack Cube

- One rack cube can be installed behind the primary door on the Media Manager Elite Lectern
- Polyethylene slides on bottom for easy removal
- Can be secured to base panel
- Compatible with most 4.75" cooling fans
- Color: black
- Factory-installed

Rack rail: 12RU front and rear
 Dimensions: 19.125"W [48.58 cm] x 19.031"D [48.34 cm] x 21.25"H [53.97 cm]
 Mounts for cooling fans: 4.13" mounting hole spacing (12 mounting locations available)

Flip-Up Shelf

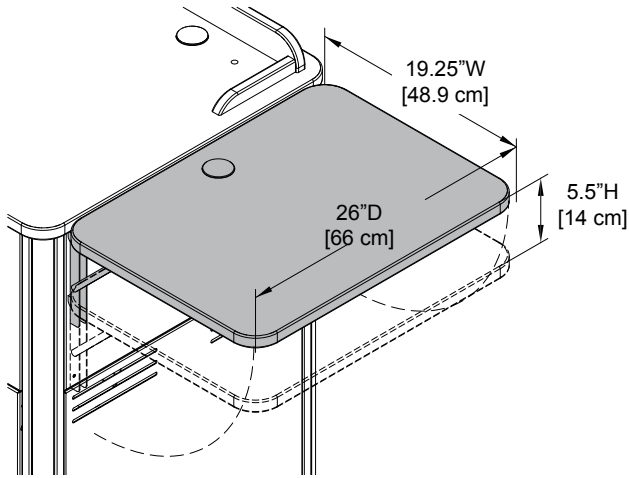

ORDER CODE 0 =	None
ORDER CODE 5 =	Flip-up Shelf (matching laminate)
ORDER CODE B =	Flip-up Shelf (Chalk white dry erase)

- Shelf hinges lock into place in the upright position
- Includes 2" grommet
- Two height-positions available
- Available in White Chalk Dry Erase laminate. Flip-up shelves configured with white laminate will have the same edgeband color as the worksurface and base panel.
- Factory-installed level with worksurface on side opposite drawer (Customer can install to lower position if necessary)

Weight capacity: 35 lb [15.9 kg]

Dimensions: 19.25"W [48.9 cm] x 26"D [66 cm] x 1"H [2.54 cm]

Note: Power and communication wiring for document cameras, laptop computers, and/or projectors placed on the flip-up shelf should be routed on top of the audience-side of the shelf. Use of the shelf grommet hole for wiring will result in pinching of the cords when the shelf is folded.

Toe Kick Kit

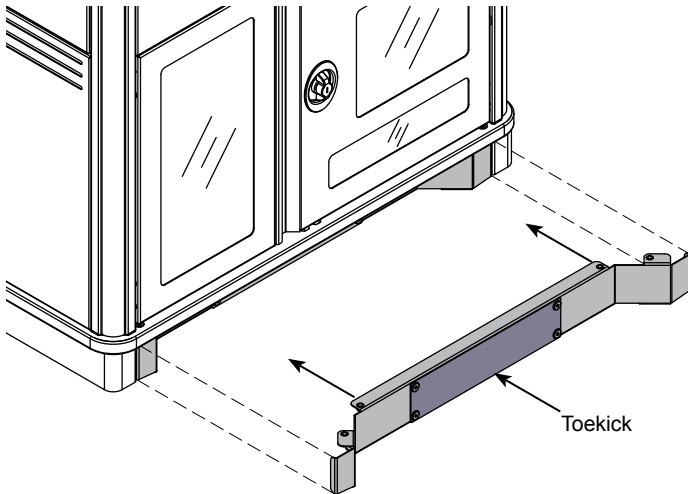

ORDER CODE 00 =	None
ORDER CODE TK =	Toekick Kit

- Attaches to floor and lectern when mobility is not necessary or desired (floor fasteners not included)
- Conceals wheels
- Includes access panel
- Customer-installed

Customized Logo Panel



ORDER CODE 0 =	None
ORDER CODE 1 =	Customized Logo Panel

- Attaches to audience-side of lectern
- 30"W [76.2 cm] x 12"H [30.5 cm]
- To get panel customized-contact Spectrum for details
- New logos require a first time logo charge
- Factory-installed

Installed Power Equipment

ORDER CODE 0 = None

ORDER CODE 1 = Power Module

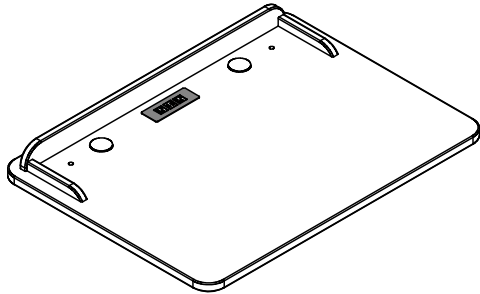

ORDER CODE 2 = Power Module & EM Wireless Charging Pad

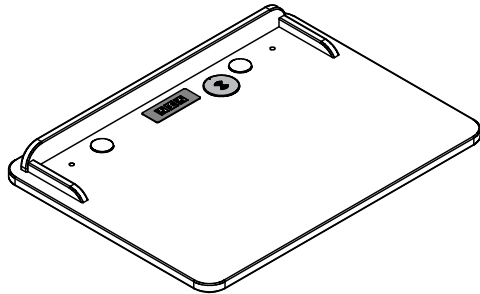

ORDER CODE 3 = EM Wireless

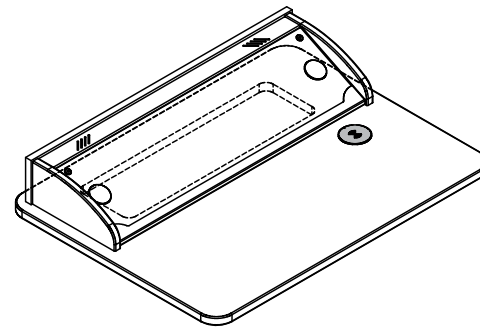
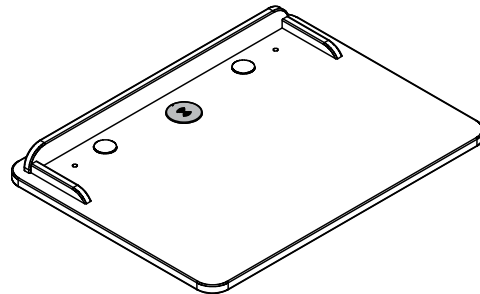

Power Module Color

ORDER CODE 0 = None



- Factory-installed
- (2) AC receptacles (tamper-resistant)
- (2) USB ports rated at 2.1A each (10.5 watts)
- Aluminum housing and flange
- 10' 14AWG *3C power cord
- When specified, the Power Module is centered on the audience-side edge of the worksurface
- Worksurface cutout size: 5.65"W x 1.65"D
- ETL-certified

ORDER CODE B = Black



ORDER CODE S = Silver



ORDER CODE W = White

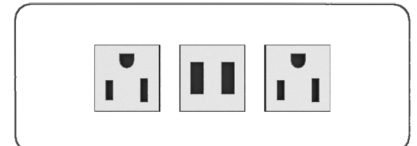

ORDER CODE 0 =	None
ORDER CODE 2 =	Yes - in Worksurface
ORDER CODE 3 =	Yes - in OB Panel
ORDER CODE 4 =	Yes - in Worksurface and OB Panel

Spectrum can provide cutouts exactly matching any commercially available data and electrical power outlet, but are only recommended within the maximum cutout areas shown. Cutouts should be reviewed by Spectrum to ensure clearance of brackets, keyboard slides, or other objects under the worksurface.

***When ordering a lectern with cutouts, specify complete details of the device(s) (brand, model number, cutout size, quantity, etc.) to the Spectrum sales rep when ordering.**

Cutouts in blank worksurfaces can be made by the customer after the lectern has been purchased, but are only recommended within the cutout areas shown.

Custom cutouts by Spectrum

- Contact Spectrum to specify cutout size(s) and location(s)
- See recommended cutout areas (shaded)

Overbridge panel cutout area

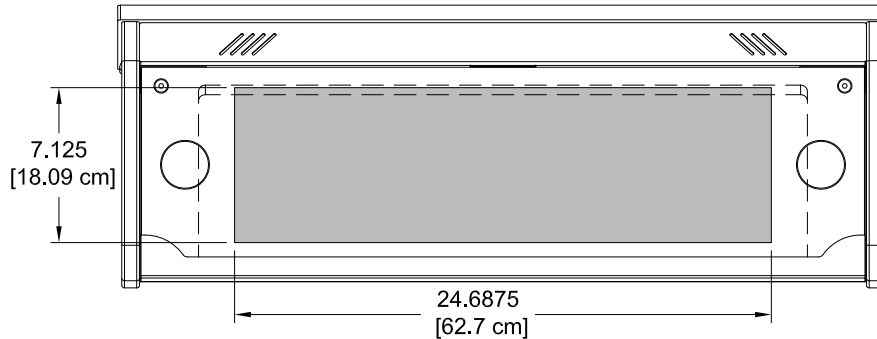

Worksurface cutout area

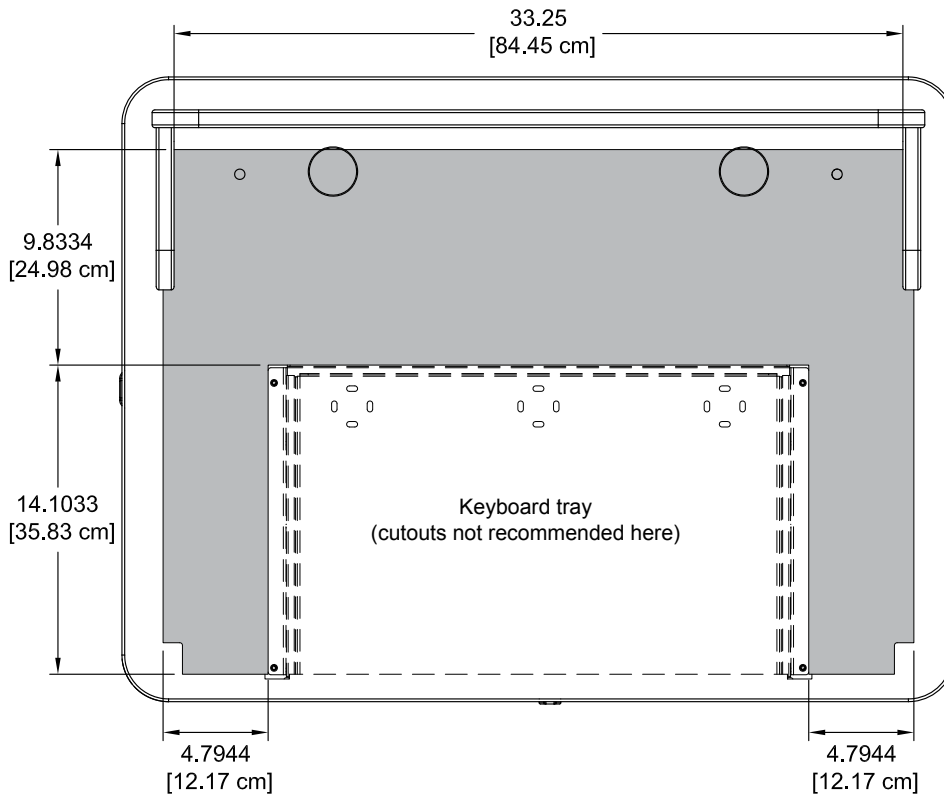

Note: Spectrum Industries, Inc. manufactures furniture that supports a wide variety of power and communication devices from a variety of manufacturers. This table is compatible with many Extron, Crestron, Altinex, AMX, and other devices. Spectrum does not resell these products; *please consult your electronic supplier* for the equipment that best suits your needs. Size specifications from the manufacturer can be used to verify the fit.



Note: Some controllers and devices require additional space around the cutout for clamping under the worksurface. Please double check your device specifications to ensure adequate space around the cutout.

Media Manager Elite Lectern with surround

(shown with drawer on left)

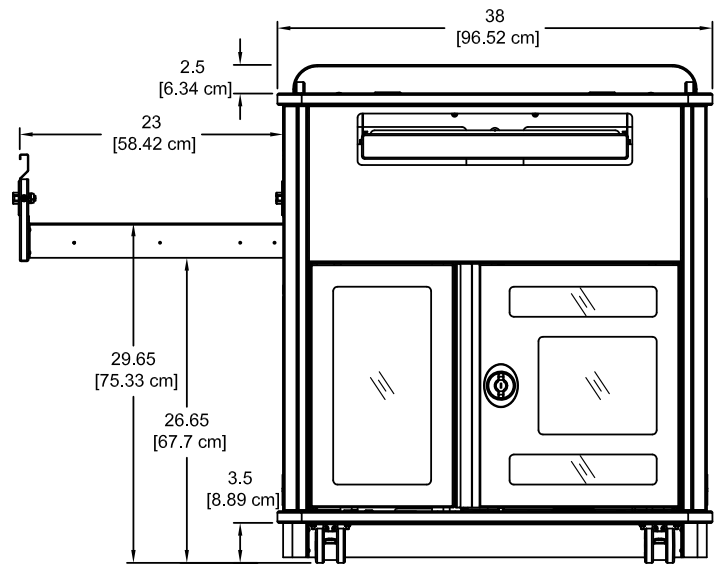
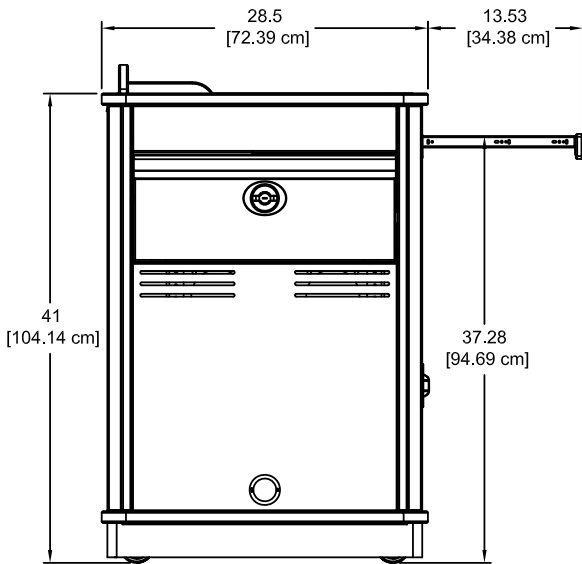
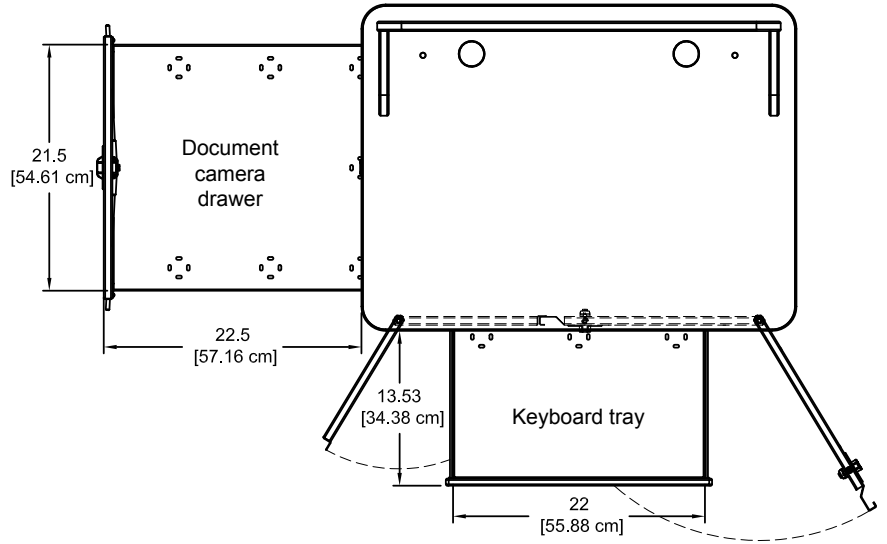
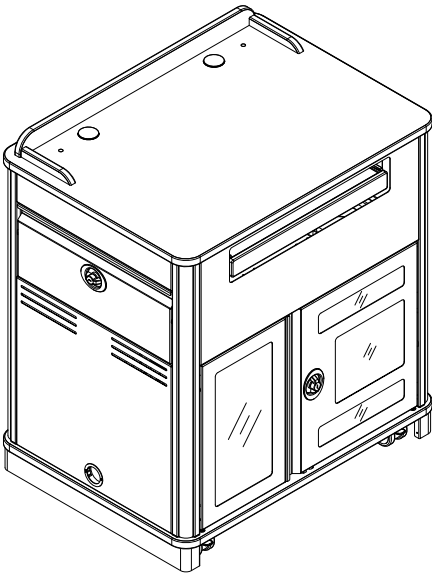

Media Manager Elite Lectern with overbridge

(Shown with drawer on right, rack cube and flip-up shelf on left, and doors removed)

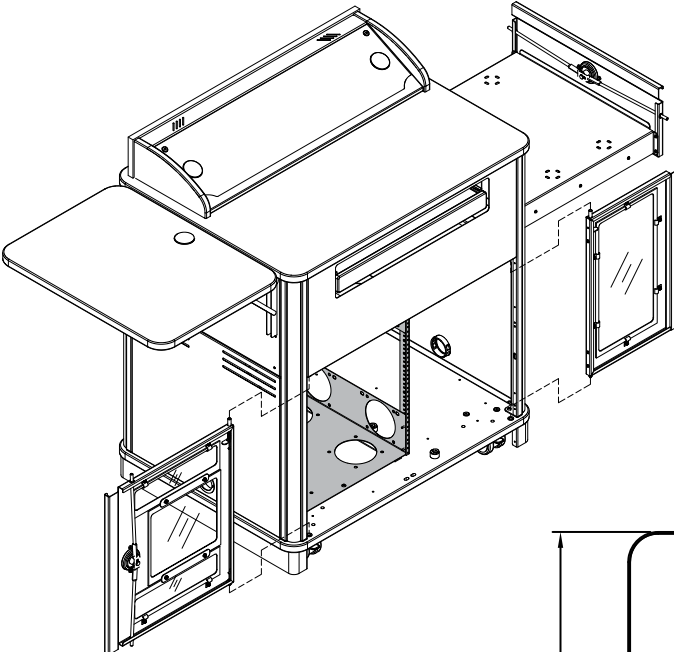

Flip-up shelf

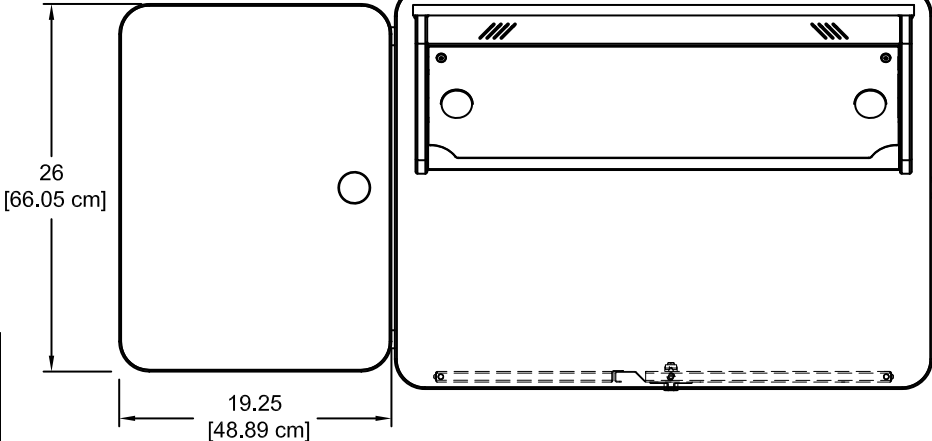

Note: Modified worksurface or overbridge insert panel cutouts should be reviewed by Spectrum to ensure clearance of brackets, keyboard slides, or other objects under the worksurface.

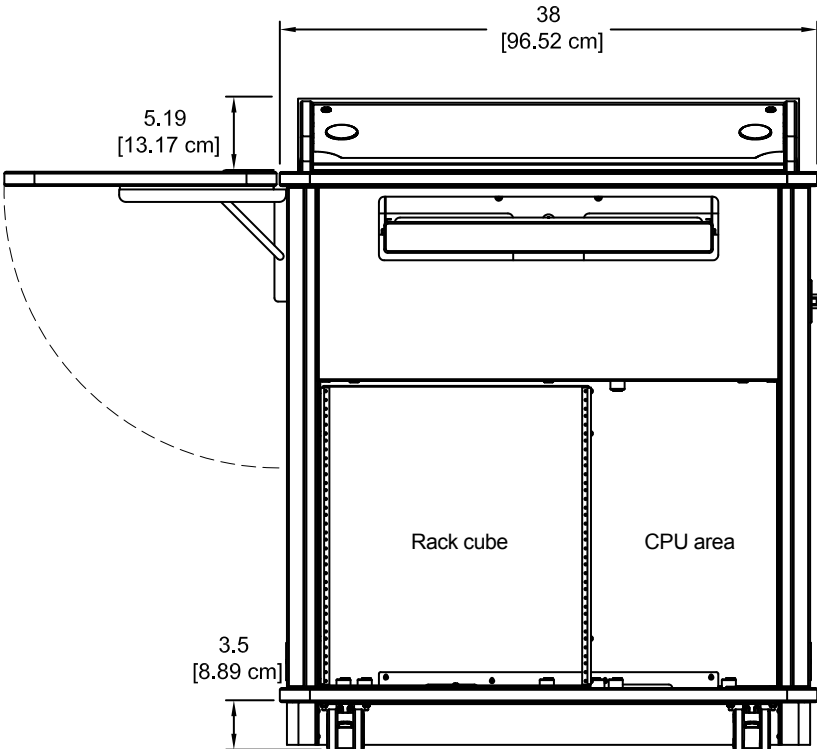
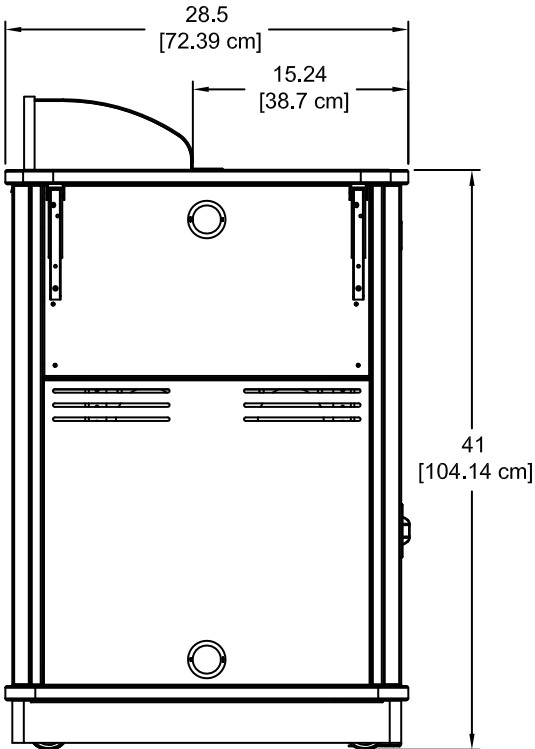

Media Manager Elite Lectern overbridge insert panel blank
(flat view)

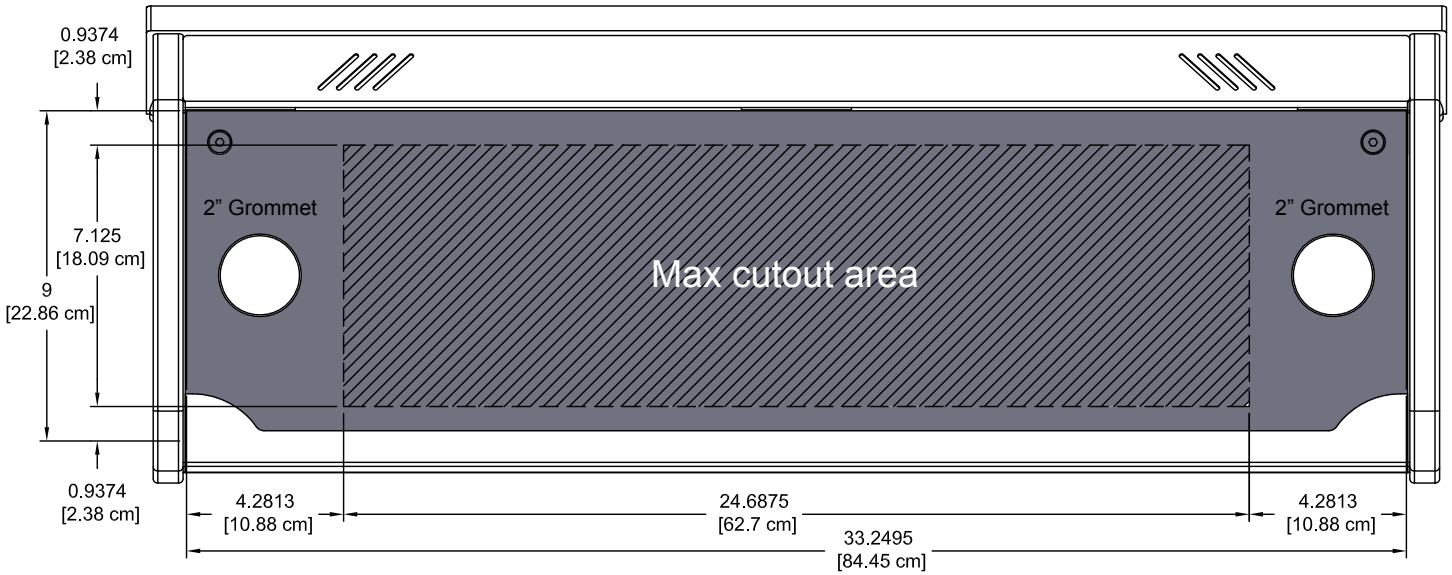

Overbridge Section View

Note: The Overbridge Control Console™ has been designed for many of the currently available controllers on the market, however, modified cutouts should be reviewed by Spectrum to ensure clearance of brackets, keyboard slides, or other objects under the worksurface.

Contact Spectrum to specify cutout size(s) and location(s).

Cutouts can be made in the blank insert panel by the customer after the lectern has been purchased, but are only recommended within the cutout area shown.

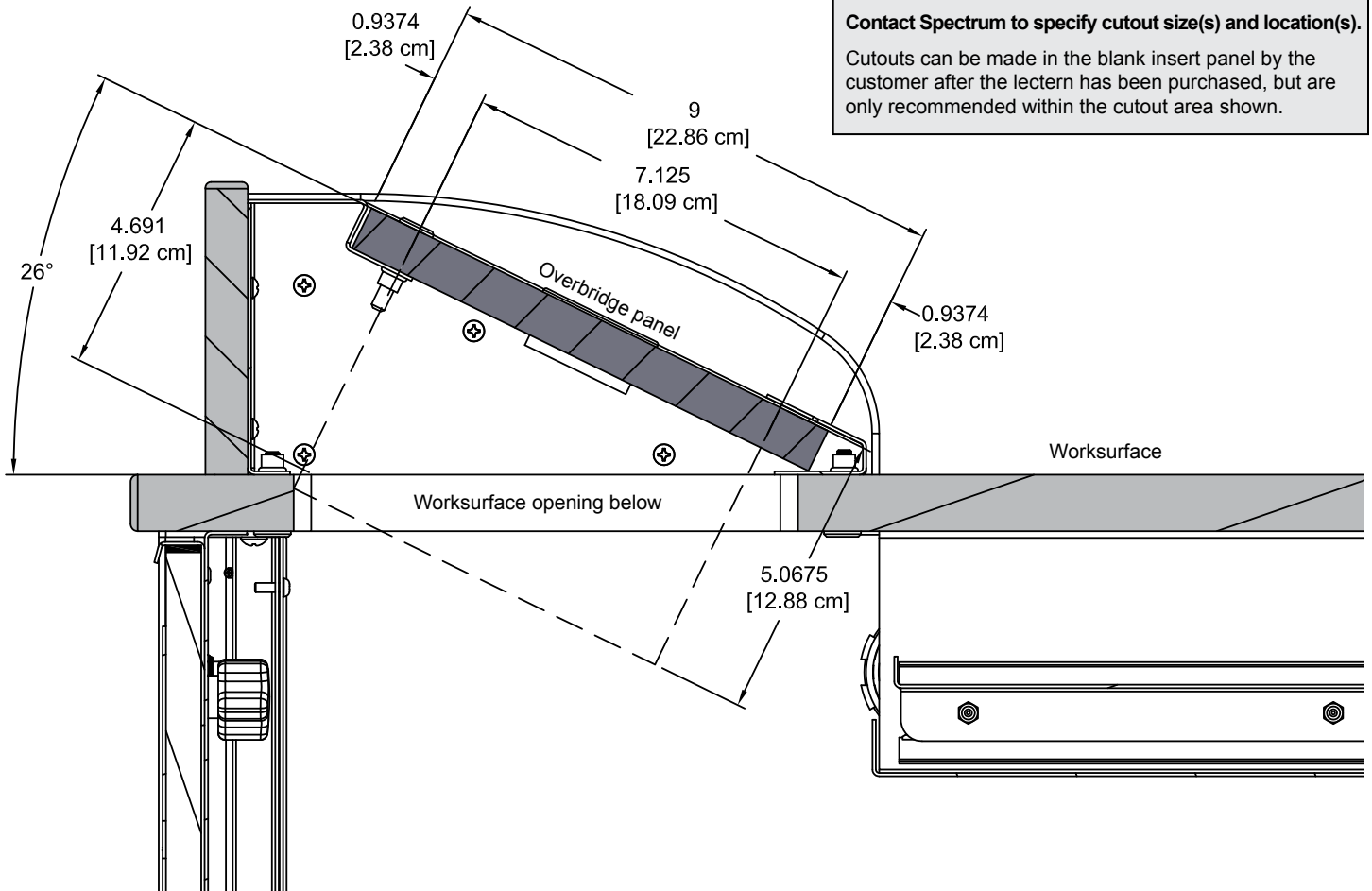

Optional 12RU Rack Cube

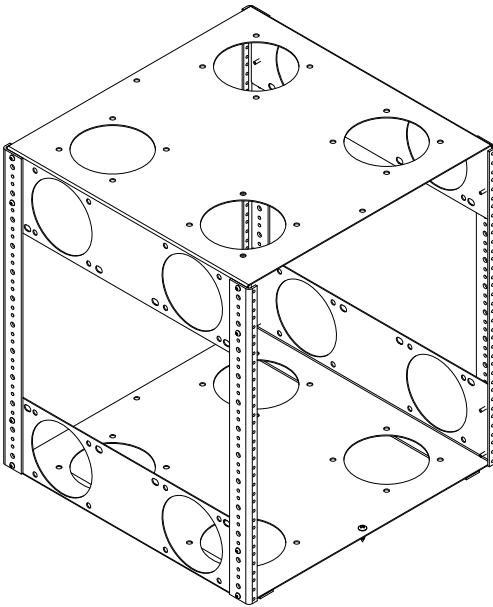

(Maximum component depth available)

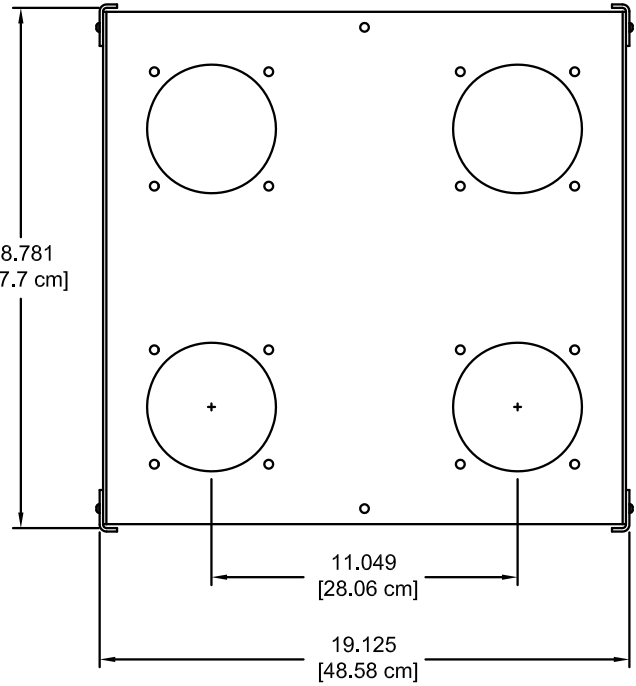

(Overall depth)

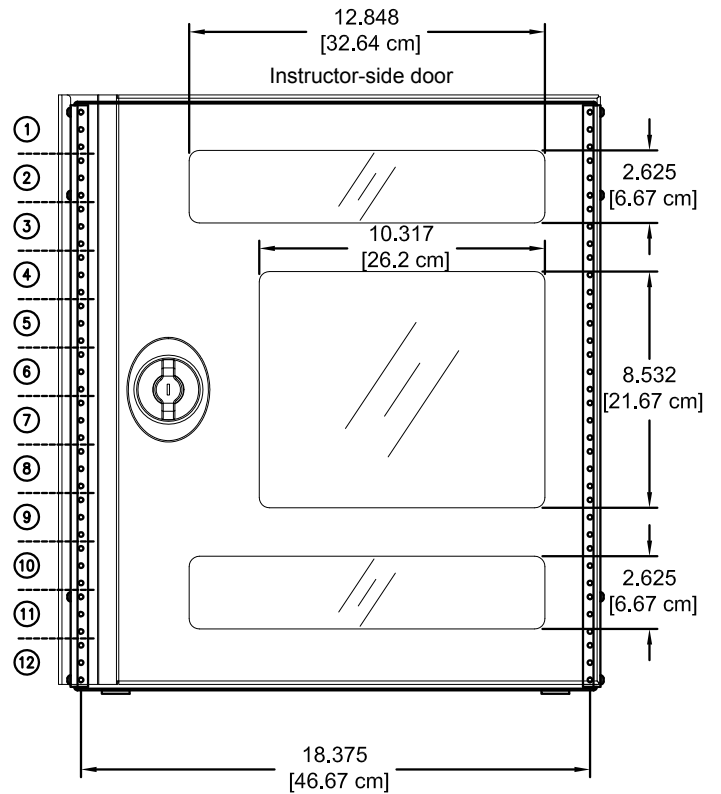
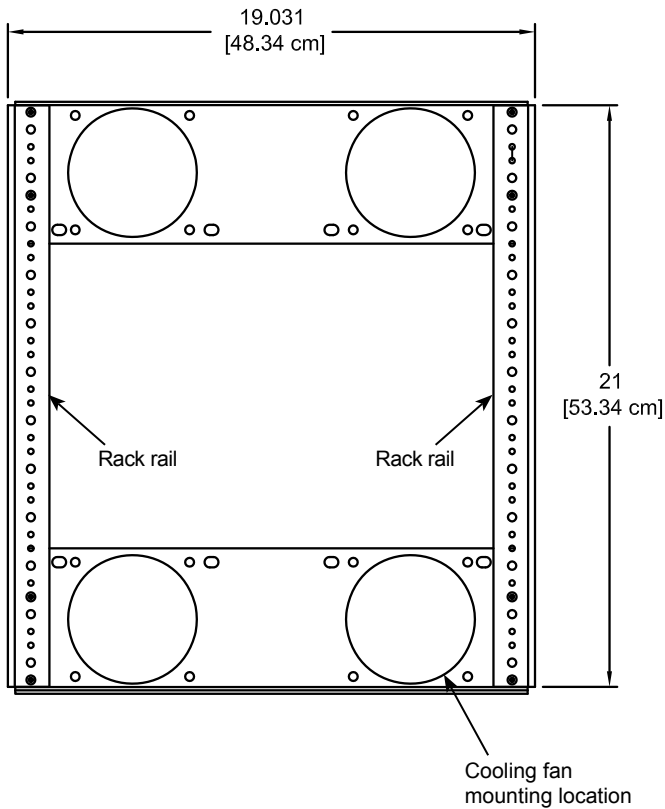

Note: Check the dimensions of all equipment before installation.

Accessories (Available separately after initial configured purchase.)

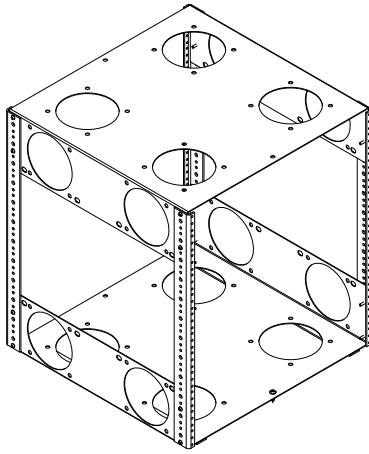

12RU Rack Cube - 55197

- One rack cube can be installed on the left or right side of the Media Manager Elite Lectern
- Polyethylene slides on bottom for easy removal
- Can be secured to base panel
- Cooling fan compatible
- Color: black
- Customer-installed

Rack rail:	12RU front and rear
Dimensions:	19.125"W [48.58 cm] x 19.031"D [48.34 cm] x 21.25"H [53.97 cm]
Mounts for cooling fans:	Compatible with most 4.7" fans with 4.13" mounting hole spacing (12 mounting locations available)
Unit weight:	21 lb [9.5 kg]
Shipping weight:	22 lb [10 kg]

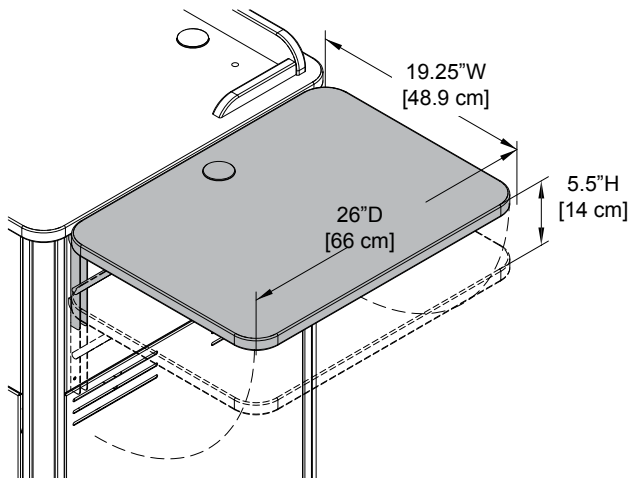

Flip-Up Shelf - 55269

- Shelf hinges lock into place in the upright position
- Includes 2" grommet
- Two height positions available
- Available in White Chalk Dry Erase laminate
- Customer-installed

Weight capacity:	35 lb [15.9 kg]
Dimensions:	19.25"W [48.9 cm] x 26"D [66 cm] x 1"H [2.54 cm]
Height positions available:	41"H [104.1 cm] (level with worksurface) 34"H [86.4 cm]
Shipping weight:	21 lb (9.5 kg)

Note: Power and communication wiring for document cameras, laptop computers, and/or projectors placed on the flip-up shelf should be routed on top of the audience-side of the shelf. Use of the shelf grommet hole for wiring will result in pinching of the cords when the shelf is folded.

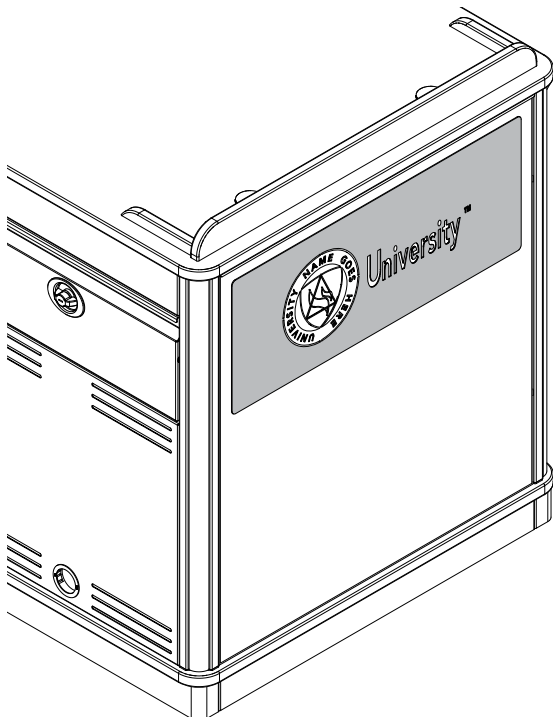

Customized Logo Panel - 55199

- Attaches to audience-side of lectern
- Available with black, white, or matching laminate backer
- To get panel customized-contact Spectrum for details
- New logos require a first time logo charge
- Customer-installed

Dimensions:	30"W [76.2 cm] x 12"H [30.48 cm]
Available logo area:	28"W [71.1 cm] x 10"H [25.41 cm]
Unit weight:	6 lb [2.7 kg]
Shipping weight:	8 lb [3.6 kg]

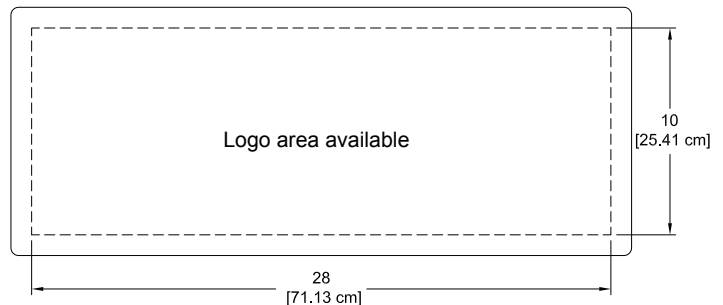

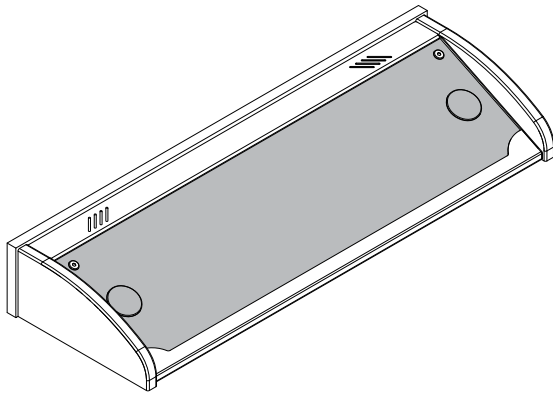

Insert panels are available to customers needing a replacement panel or different cutouts for technology upgrades.

Overbridge Insert Panel-Large - 96507

- Panel for overbridge version only (overbridge not available separately)
- Contact Spectrum to specify cutout size(s) and position(s)
- Includes two 2" [5.08 cm] grommets with covers
- Customer-installed

Dimensions:	33.25"W [84.5 cm] x 9"D [22.9 cm] x .79"H [2 cm]
Unit weight:	N/A
Shipping weight:	8.5 lb [3.9 kg]

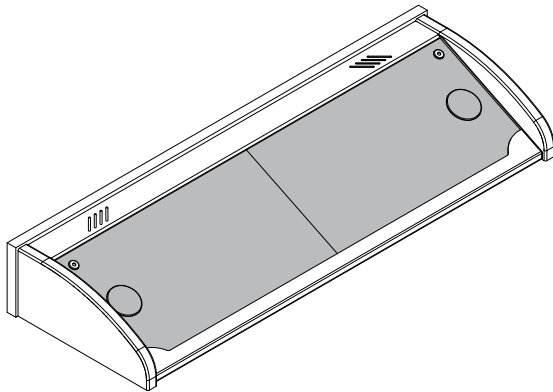

Two-piece Overbridge Insert Panel-Large - 96513

- Split panel for overbridge version only
- Contact Spectrum to specify cutout size(s) and position(s)
- Includes 2" [5.08 cm] grommets with covers
- Customer-installed

Dimensions:	16.625"W [42.23 cm] x 9"D [22.86 cm] x .79"H [2 cm]
Unit weight:	N/A
Shipping weight:	8.5 lb [3.9 kg]

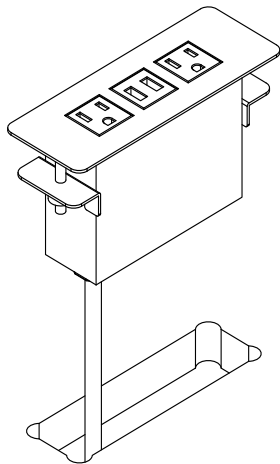

Power Module - 99058

- (2) AC power receptacles
- (2) USB charge ports
- Aluminum housing and flange
- Thumbscrew clamps
- Requires worksurface cutout
- ETL-certified
- Available in black, silver, or white
- Customer-installed

Cutout required:	5.65"W [14.35 cm] x 1.65"D [4.19 cm]
Power cord:	10' [305 cm] 14AWG *3C power cord
Power receptacles:	125V, 60hz, 15A tamper-resistant
USB charging ports:	2.1A (10.5W) (not data-compatible)
Dimensions:	6.38"W [16.2 cm] x 2.36"D [6 cm] x 3.54"H [9 cm]
Unit weight:	2 lb [.9 kg]
Shipping weight:	2.35 lb [1 kg]

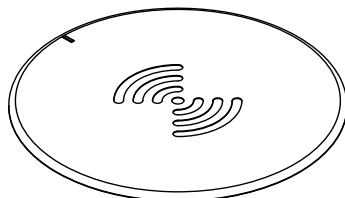

EM Wireless Charging Pad - 99057

- Uses electromagnetic technology to charge Qi V1.2 compliant IC devices ("Qi" enabled)
- LED to confirm pairing / charging
- Security tab prevents theft
- Requires 3" round cutout to be made by customer
- UL-certified

Cutout required:	3" dia (by customer)
Input:	DC 5V (with included DC5V.2A power adapter)
Output:	5W max (with included DC5V.2A power adapter)
Power cord:	8' [244 cm] with DC jack
Dimensions:	3.5" dia [8.9 cm] x 1.125"H [2.9 cm]
Shipping weight:	1 lb [.45 kg]

Note: The unit requires a 7" diameter of clearance to work with Qi-enabled phones placed in any orientation. The 3" dia cutout should be located on the worksurface at least 3.5" from any edge.

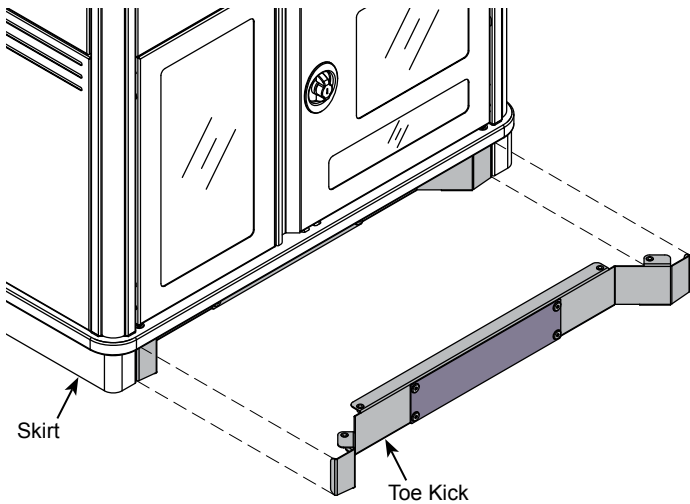

Toe Kick Kit - 55198

- Attaches to floor and lectern when mobility is not necessary or desired (floor fasteners not included)
- Conceals casters
- Includes access panel
- Customer-installed
- Shipping weight: 12 lb [5.4 kg]

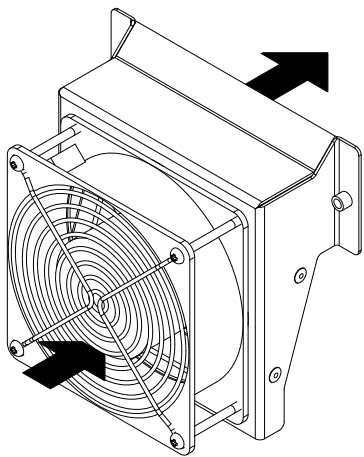

Cooling Fan for Media Manager Series Lecterns - 99051

- Exhausts hot air from inside lectern
- Installs inside lectern at top of rack cabinet
- Mounts to side panel vent slots with two screws
- Customer-installed

Electric Fan:	<ul style="list-style-type: none"> • Voltage: 115VAC (single phase) • Power: 5.5W • Current: .08A • 1450 RPM • Dimensions: 119 mm x 119 mm • Ball Bearing 	<ul style="list-style-type: none"> • Noise: 28 dB • Air flow: 49.4 CFM (1.40m³/min) • Frame material: Aluminum • Blade material: Polycarbonate, Fiberglass reinforced
Power cord:	18ga, 48" nominal length, 6A 125V~ (2 prong plug)	
Mounting bracket:	<ul style="list-style-type: none"> • 16-gauge steel • Black powder coat • Mounting screws included 	
Unit weight:	2.3 lb [1.05 kg]	
Shipping weight:	3 lb [1.36 kg]	

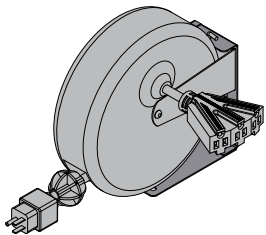

Universal Cord Reel Kit - 99037

- Includes universal mounting bracket
- Mounts inside lectern to base panel
- Adjustable ball stop and releasable cord-locking ratchet holds the cord at any length up to 15'
- cUL listed
- Customer-installed

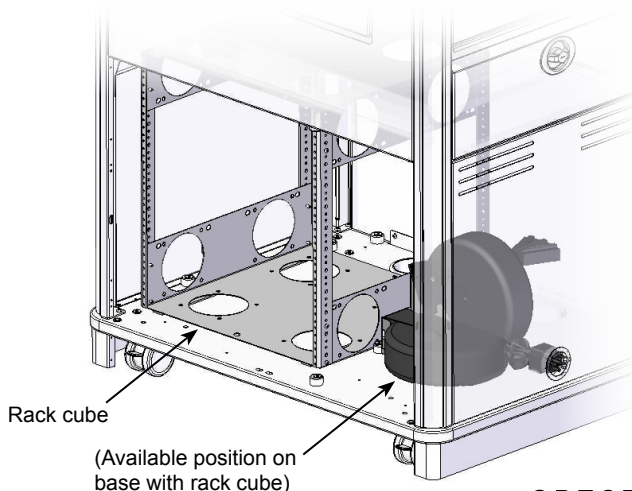

Power cord:	15' nominal, 12 AWG retractable power cord
Power receptacles:	<ul style="list-style-type: none"> • Molded 3-prong male plug with 15A breaker and reset button • Tri-tap (3-outlet) receptacle
Universal mounting bracket:	<ul style="list-style-type: none"> • 16-gauge steel • Black powder coat • Includes mounting screws
Unit weight:	10 lb [4.5 kg]
Shipping weight:	10.8 lb [4.9 kg]

The cord reel is intended to provide temporary access to electrical outlets for Spectrum mobile lecterns. Check local electrical codes prior to installation.



Flat Panel Monitor Arm

95512 - "Light-Duty" for monitors weighing 2-13 lb [.9-5.9 kg]

95522 - "Medium-Duty" for monitors weighing 7.5-25 lb [2.5-11.4 kg]

95509 - "Heavy-Duty" for monitors weighing 12-31 lb [5.4-14 kg]

- Six mounting options (clamp, thru-desk, wall, grommet hole, side bolt, reverse wall)
- Compatible with all VESA® monitors – includes 75mm and 100mm VESA® adapters
- Cable management concealed in arm

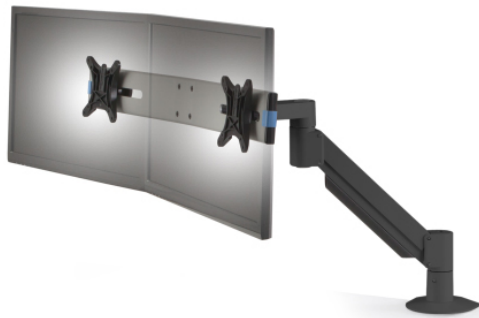

Dual Flat Panel Monitor Arm - 95533

- Weight range: 3.5-13 lb [1.6-5.9 kg] per monitor
- Six mounting options (clamp, thru-desk, wall, grommet hole, side bolt, reverse wall)
- Compatible with all VESA® monitors – includes 75mm and 100mm VESA® adapters
- Cable management concealed in arm

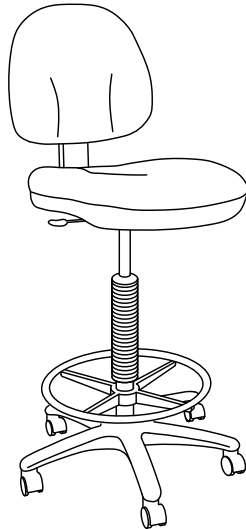

Adjustable Drafting Stool - 38202

- 40-52" height-adjustment via pneumatic cylinder
- 360° swivel
- Tilting backrest
- 18" diameter fixed foot ring
- 5-star base

Rack-mount Accessories

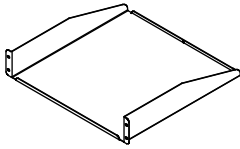

Cantilever Shelf - 2RU - 97504

- 16ga steel
- Shelf: 17.5"W [44.45 cm] x 18"D [45.7 cm] x 3.5"H [8.89 cm]
- Weight capacity: 50 lb [22.7 kg]
- Shipping weight: 8.1 lb [3.7 kg]

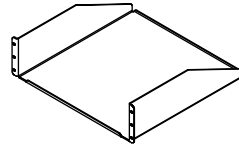

Cantilever Shelf - 3RU - 97502

- 16ga steel
- Shelf: 17.5"W [44.45 cm] x 18"D [45.7 cm] x 5.25"H [13.33 cm]
- Weight capacity: 80 lb [36.3 kg]
- Shipping weight: 9.2 lb [4.2 kg]

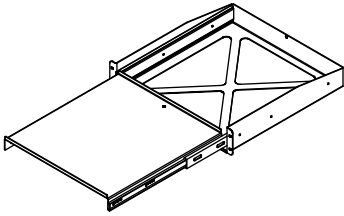

Pull-Out Shelf - 2RU - 97505

- 16ga steel
- 17.09"W [43.42 cm] x 18.12"D [46.03 cm] x 3.5"H [8.89 cm]
- Weight capacity: 50 lb [22.7 kg]
- Shipping weight: 15.6 lb [7.1 kg]

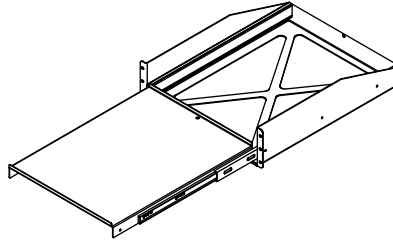

Pull-Out Shelf - 3RU - 97503

- 16ga steel
- 17.09"W [43.42 cm] x 22.11"D [56.14 cm] x 5.25"H [13.33 cm]
- Weight capacity: 80 lb [36.3 kg]
- Shipping weight: 18.5 lb [8.4 kg]

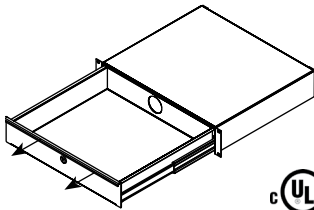

Locking Drawer - 2RU - 97523

- 16ga steel
- Drawer: 15.97"W [40.56 cm] x 14.56"D [36.98 cm] x 3"H [7.63 cm]
- Weight capacity: 50 lb [22.7 kg]
- Shipping weight: 15.85 lb [7.2 kg]

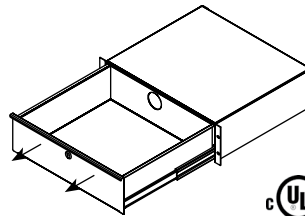

Locking Drawer - 3RU - 97522

- 16ga steel
- Drawer: 15.97"W [40.56 cm] x 14.56"D [36.98 cm] x 5.25"H [13.33 cm]
- Weight capacity: 50 lb [22.7 kg]
- Shipping weight: 18.5 lb [8.4 kg]

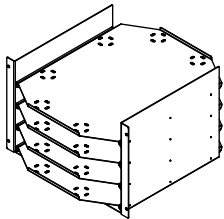

LT-4 Laptop Storage Unit - 7RU - 97517

- Holds four full-size laptops
- 16ga & 20ga steel
- 18.75"W [47.94 cm] x 20.5"D [52.11 cm] x 12.25"H [31.11 cm]
- Shipping weight: 30 lb [13.6 kg]

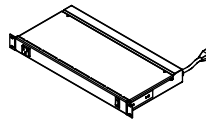

9-Outlet Power Strip - 1RU - 99021

- 8 outlets rear (breaker-protected)
- 1 convenience outlet front
- 115VAC, 60 Hz, 15 amps max
- 9' power cord
- Front LED power switch
- Enhanced surge protection
- ETL-listed, UL-listed
- 19"W [48.27 cm] x 9.25"D [23.5 cm] x 1.74"H [4.41 cm]
- Shipping weight: 8.7 lb [3.9 kg]

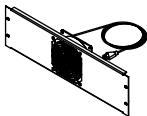

Single Fan - 3RU - 97507

- 50 cfm
- 120V~50/60 Hz, 15/13W
- RoHS
- 19"W [48.27 cm] x 1.56"D [3.97 cm] x 5.25"H [13.33 cm]
- Shipping weight: 3.78 lb [1.7 kg]

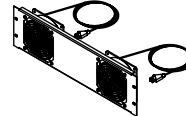

Double Fan - 3RU - 97506

- 100 cfm
- 120V~50/60 Hz, 15/13W
- RoHS
- 19"W [48.27 cm] x 1.56"D [3.97 cm] x 5.25"H [13.33 cm]
- Shipping weight: 5.47 lb [2.5 kg]

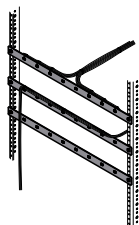

Wire Lace Kit - 95517

- Provides wire management
- Mounts to standard rack rails
- Includes (3) lace straps and mounting screws
- Includes (12) 5.5" zip ties
- Shipping weight: 1.25 lb [.57 kg]

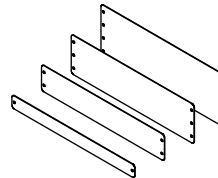

Rack-Mount Blanks

1RU - 97510 **3RU - 97512**
2RU - 97511 **4RU - 97513**

- Fills rack spaces where components are not needed
- 16 ga steel
- Shipping weight: <1 lb [.45 kg]

See spectrumfurniture.com for the latest accessories and detailed warranty information.

Warranty

We will make it right for you!

Spectrum is committed to provide complete customer satisfaction. Each of our products is manufactured from the best materials available and each product is stringently monitored throughout the production process through our Quality Management System.

We expressly warrant that Spectrum products will be of good quality and workmanship and free from defect for the period set out in the warranty table below from the date of delivery. This warranty shall not apply to defects or damage resulting from normal wear and tear, misuse, or unintended use, failure to follow instructions related to the product's installation or intended use, abuse, neglect, improper care, modification or repair not authorized by Spectrum, or any other cause outside the control of Spectrum. Spectrum will, at its sole option, either repair or replace the defective product.

This warranty is exclusive; no other warranty, written or oral, is expressed or implied. This warranty is given by Spectrum to Buyer or Buyer third party end user and to no other person or legal entity. No Spectrum dealer, distributor, partner, reseller, agent or employee is authorized to make any modification or addition to this warranty.

NOTWITHSTANDING ANYTHING TO THE CONTRARY, SPECTRUM WILL NOT UNDER ANY CIRCUMSTANCES BE LIABLE FOR INDIRECT OR LIQUIDATED DAMAGES, INCLUDING CONSEQUENTIAL, INCIDENTAL AND SPECIAL DAMAGES. IN NO EVENT SHALL SPECTRUM'S LIABILITY, WHETHER UNDER CONTRACT OR WARRANTY, IN TORT OR OTHERWISE, EXCEED THE PURCHASE PRICE RECEIVED BY SPECTRUM FOR THE PRODUCT AT ISSUE AND "RECALL ACTION" EXPENSES. SPECTRUM SHALL NOT BE SUBJECT TO ANY OTHER OBLIGATIONS OR LIABILITIES, WHETHER ARISING OUT OF BREACH OF CONTRACT, WARRANTY, TORT (INCLUDING NEGLIGENCE AND STRICT LIABILITY) OR OTHER THEORIES OF LAW, WITH RESPECT TO PRODUCTS SOLD OR SERVICES RENDERED BY SPECTRUM, OR ANY UNDERTAKINGS, ACTS OR OMISSIONS RELATING THERETO.

Our Customer Service Department is ready to provide immediate attention to any questions, comments or concerns. They are available to answer your calls Monday through Friday from 7 am to 5 pm CST. In addition your product comments or concerns are welcome via e-mail at: spectrum@spectrumfurniture.com.

Warranty Table

Item	Warranty Period
Desk, table, cart and lectern chassis	10 Years
Electrical	2 Years
Flat panel monitor arms / gas spring / general parts	2 Years
Adjustable crank / electric legs and accessories	2 Years
Flat panel desk gas spring cylinders	2 Years
Height adjustable columns, lifts & accessories	2 Years
Casters & wheels	2 Years
Keyboard, mouse, trays	2 Years
Locks & keys	2 Years
Tubs, totes and other accessories	1 Year
Chairs	7 Years
Structural components, including gas cylinders, wood, metal and plastic parts (i.e., chair frames, bases and control handles)	
Consumable items (i.e., casters, glides, etc.)	
In-stock upholstery	5 Years
Customer supplied material	No Warranty



Spectrum Industries Inc.
is Certified ISO 9001:2015