

Assembly Instructions:



(4) 052605
1/4-20 x 15mm JC Bolt



(6) 021587
8-32 x 1/2" PHMS



(6) 029019
8-32 Locknut



(8) 026073
#8 x 3/4" PHSM

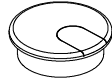

(1) 039622
2" Grommet

Tools Required:
Phillips Screwdriver
Adjustable Wrench

Before you begin, please make sure all parts and proper quantities are included. Any parts damaged during shipment must be reported within 15 days of receipt. To report information regarding damages or if you have any questions, please call 1-800-235-1262.

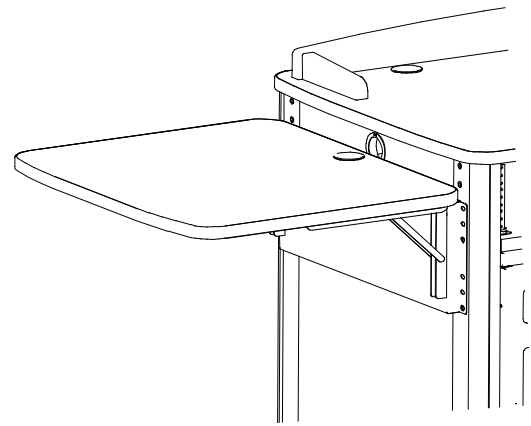

Media Director V2 Flip-Up Shelf #55263

1. Attach Folding Brackets to Shelf Support

A. Attach the (2) Folding Brackets to the Shelf Support with (6) 8-32 x 1/2" PHM Screws and Locknuts (3 per bracket) as shown in **Figure 1**. Tighten securely.

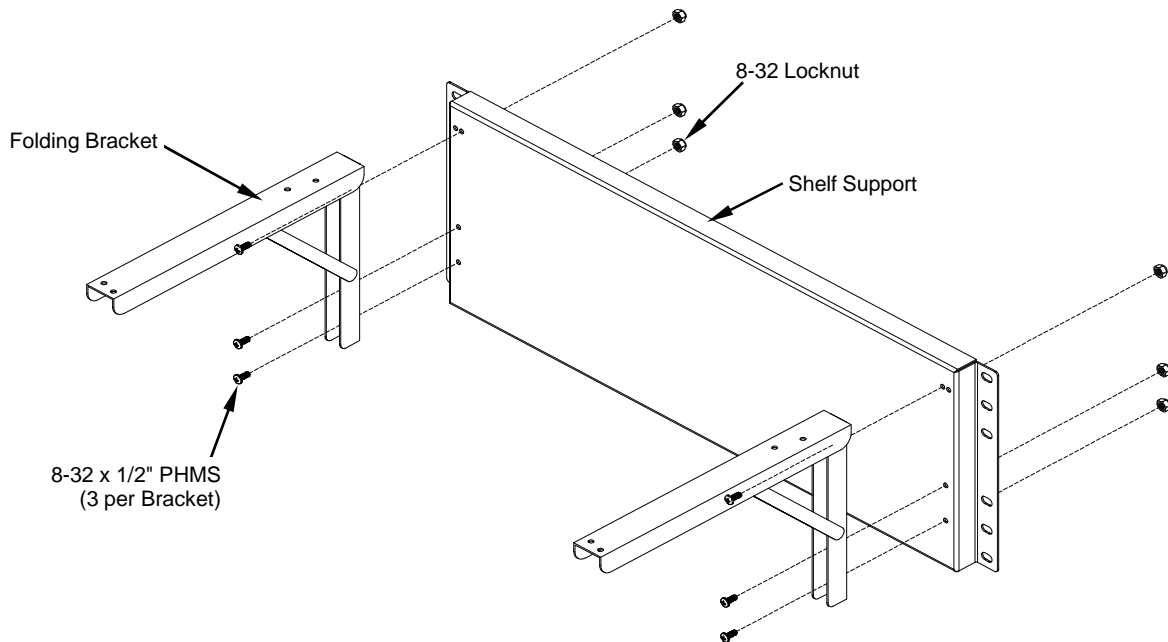

Figure 1

Touchboards

205 Westwood Ave, Long Branch, NJ 07740
Phone: 866-94 BOARDS (26273) / (732)-222-1511
Fax: (732)-222-7088 | E-mail: sales@touchboards.com

2. Attach Shelf Support/Bracket Assembly to the Lectern

- A. Determine the preferred side of the lectern to locate the shelf.
- B. Attach the Shelf Support/Bracket Assembly to the Lectern using (4) 1/4-20 x 15mm JC Bolts. This assembly can be mounted at several different heights depending on the application. **Figure 2.** (This Shelf is shown in the upper position.)

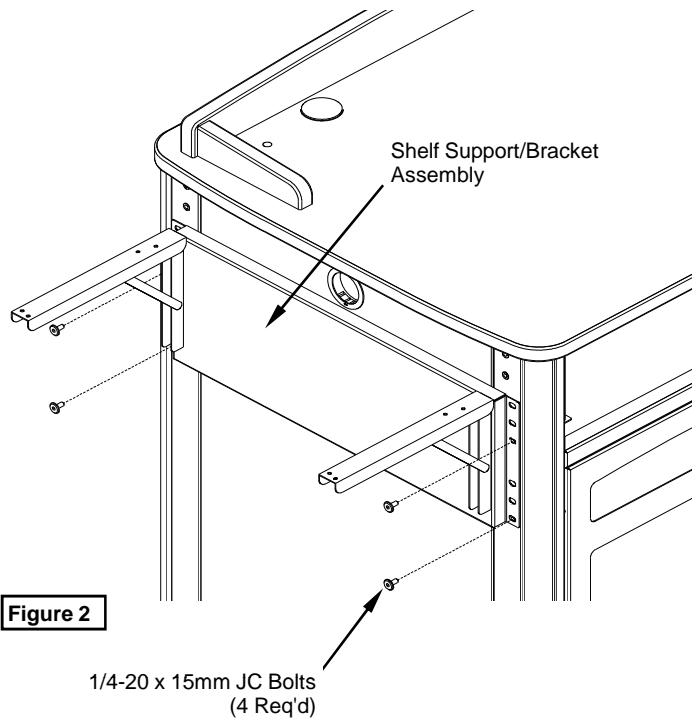

Note: If you are mounting the Flip-up Shelf to a lectern with a Handle, the Shelf and Handle can be on the same side if preferred, but the Shelf needs to be mounted in the middle or lower position.

Figure 2

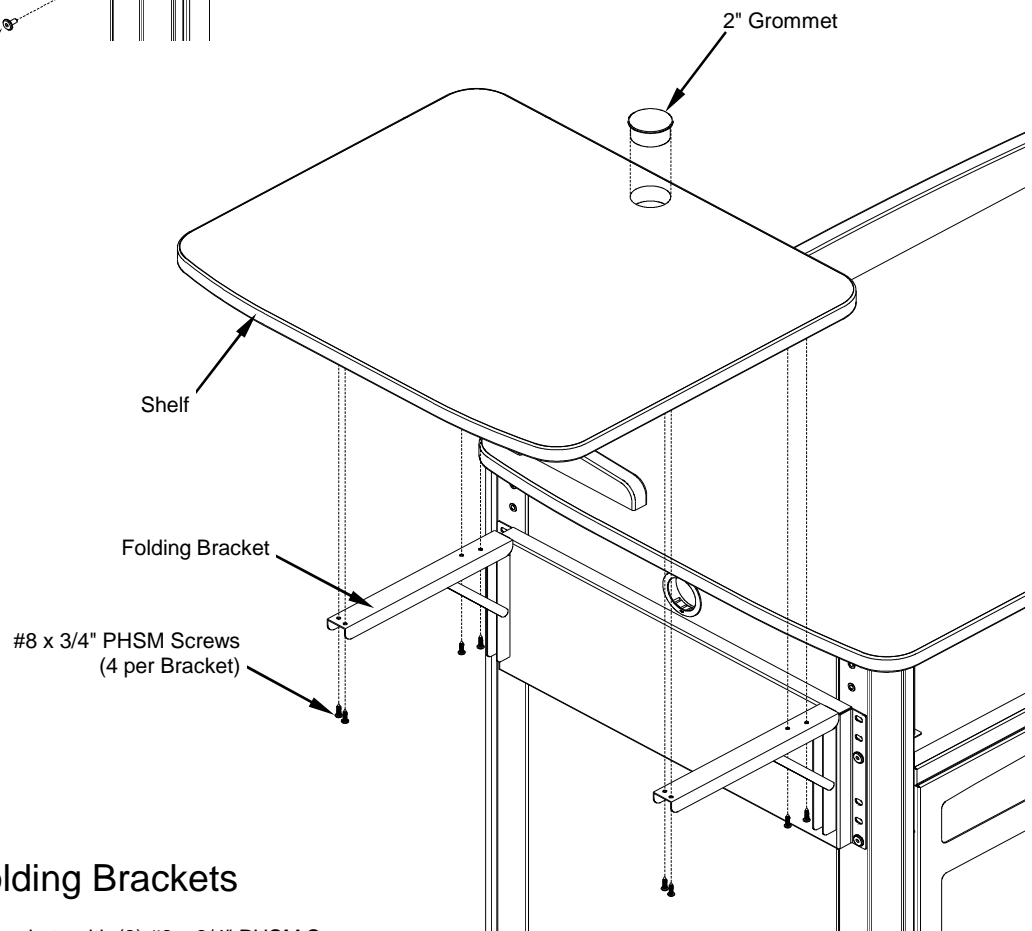

3. Attach Shelf to Folding Brackets

- A. Attach the Shelf to the (2) Folding Brackets with (8) #8 x 3/4\" PMSM Screws (4 per bracket) as shown in **Figure 3.** Tighten securely.
- B. Install the 2\" Grommet.

Figure 3