



Assembly Instructions:

To purchase parts or accessories, please contact us at
www.spectrumfurniture.com
 1-800-235-1262
 Thank you for choosing Spectrum products!

 (4) 044541
 1/4-20 x 20mm JC Bolt

 (1) 025039
 4mm Hex Wrench

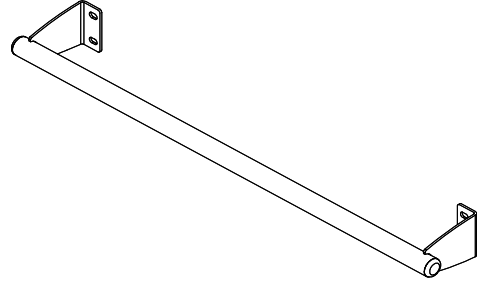

Before you begin, please make sure all parts and proper quantities are included. Any parts damaged during shipment must be reported within 15 days of receipt. To report information regarding damages or if you have any questions, please call 1-800-235-1262.

Steel Handle #55265
 for Flat Panel Monitor Cart V2,
 Media Director V2, vLT-15, vLT30

Handle Assembly

Tools Required:
 4mm Hex Wrench (included)

- A. Determine which side of the lectern the handle is to be mounted and locate the four mounting holes.
- B. Attach the handle with (4) 1/4-20 x 20mm JC bolts as shown and tighten securely. **Figure 1.**

Note: On units with flip-up shelves, the handle can be mounted on the same side as the flip-up shelf, but the shelf may need to be repositioned (lowered) on some units to accommodate the handle. (See **Figure 2.**)

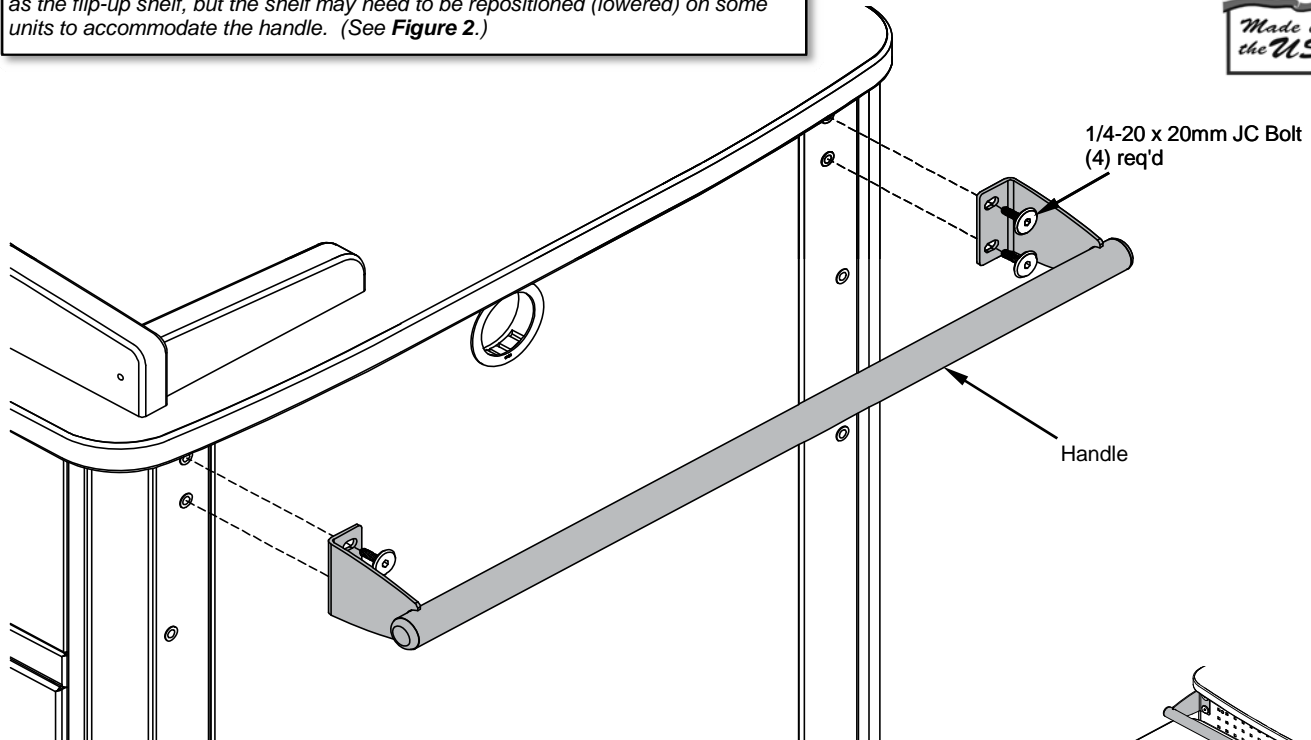
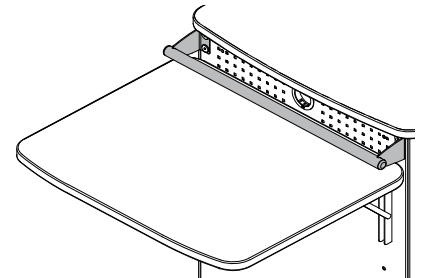

Figure 1



Handle and Flip-up shelf installed on the same side of unit.

Figure 2



Touchboards

205 Westwood Ave, Long Branch, NJ 07740
 Phone: 866-94 BOARDS (26273) / (732)-222-1511
 Fax: (732)-222-7088 | E-mail: sales@touchboards.com

SPECTRUM
 INDUSTRIES INC.

925 First Avenue, PO Box 400, Chippewa Falls, WI 54729 Ph: 1-800-235-1262 Fax: 1-800-335-0473

E-mail: spectrum@spectrumfurniture.com web: www.spectrumfurniture.com