

# Assembly Instructions:

To purchase parts or accessories, please contact us at  
[www.spectrumfurniture.com](http://www.spectrumfurniture.com)  
1-800-235-1262  
Thank you for choosing Spectrum products!

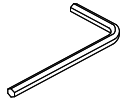

(4) 052605  
1/4-20 x 15mm JC Bolts



(1) 025039  
4mm Hex wrench

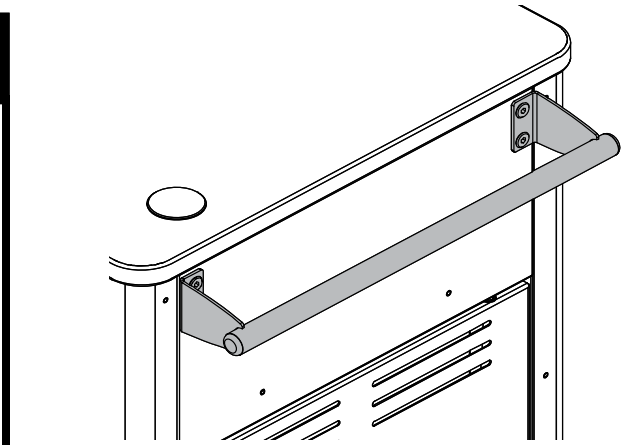

## Handle for Moderator #55393

Before you begin, please make sure all parts and proper quantities are included. Any parts damaged during shipment must be reported within 15 days of receipt. To report information regarding damages or if you have any questions, please call 1-800-235-1262.

Tools Required:  
4mm Hex wrench (included)

### Attaching Handle

- Align the handle with the mounting holes. **Figure 1.**
- Install (4) 1/4-20 x 15mm JC bolts and tighten securely.

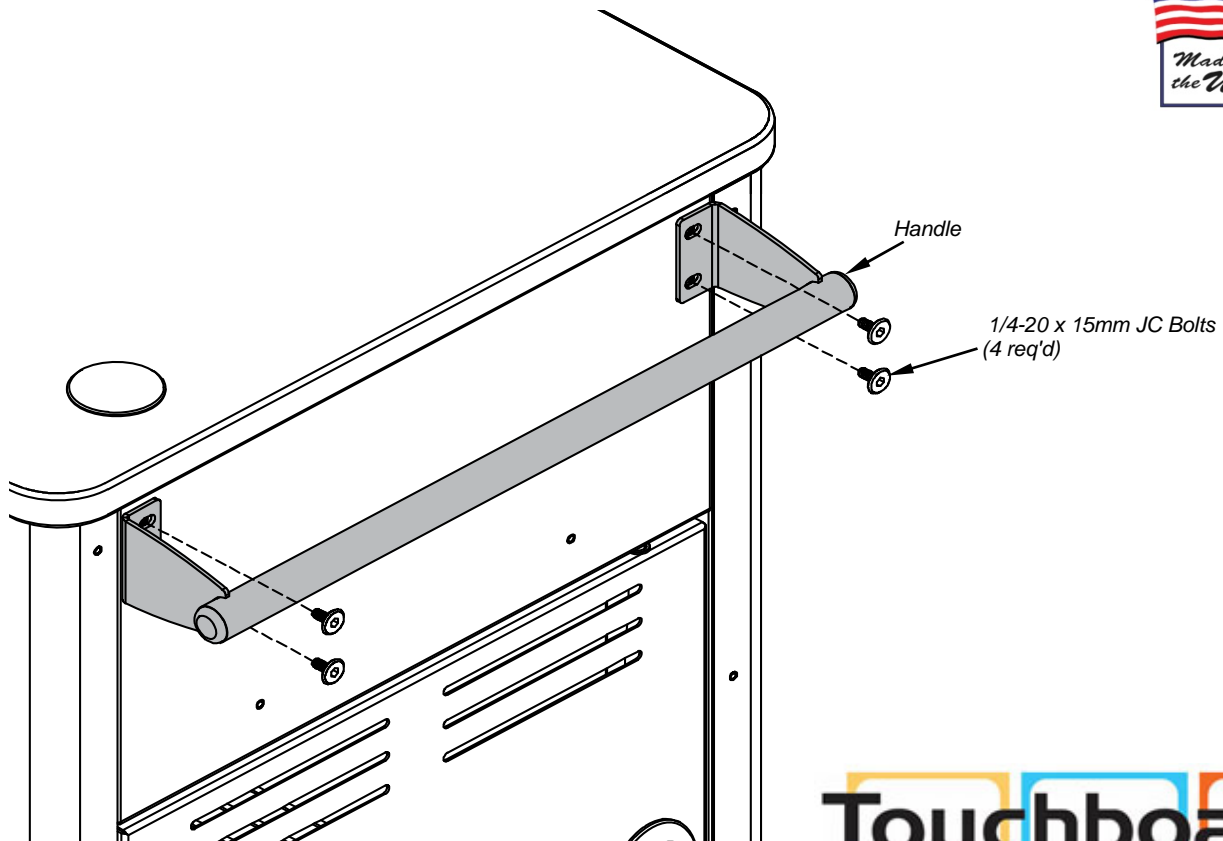

Figure 1

# Touchboards

205 Westwood Ave, Long Branch, NJ 07740  
Phone: 866-94 BOARDS (26273) / (732)-222-1511  
Fax: (732)-222-7088 | E-mail: [sales@touchboards.com](mailto:sales@touchboards.com)

**SPECTRUM**  
INDUSTRIES INC.

925 First Avenue, PO Box 400, Chippewa Falls, WI 54729 Ph: 1-800-235-1262 Fax: 1-800-335-0473

E-mail: [spectrum@spectrumfurniture.com](mailto:spectrum@spectrumfurniture.com) web: [www.spectrumfurniture.com](http://www.spectrumfurniture.com)