

Technical Specifications

55394

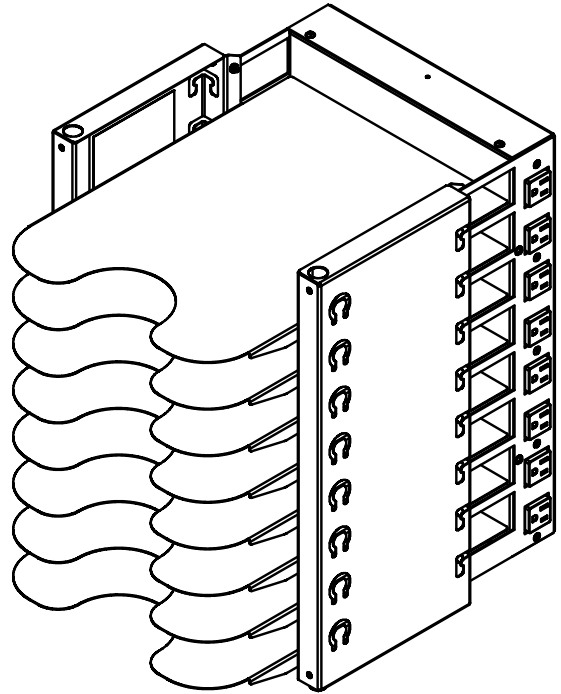

205 Westwood Ave, Long Branch, NJ 07740
 Phone: 866-94 BOARDS (26273) / (732)-222-1511
 Fax: (732)-222-7088 | E-mail: sales@touchboards.com

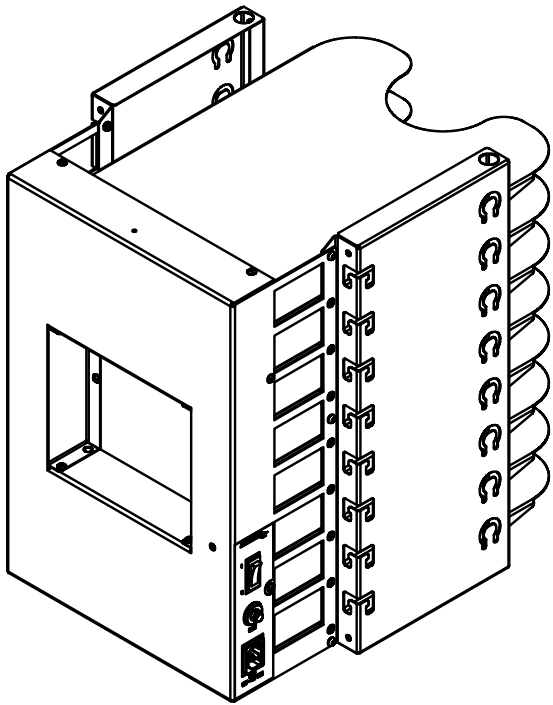

Use the Collectiv8™ Charging Pillar to store and charge up to 8 devices (tablets, Chromebooks™, or notebooks). Wiring slots keep cords organized and speed wiring to each bay. The Collectiv8 Pillar's small footprint covers less counter space, and is made with powder-coated steel for durability.



Features and Benefits

- Stores and charges up to 8 devices tablets, Chromebooks™, or notebooks
- 11"W [27.94 cm] x 14.933"D [37.93 cm] x 1.964"H [5 cm] storage bay
- Durable 16ga steel trays
- Unit can be anchored to a floor, permanent worksurface or wall for additional stability and security
- A second unit can be stacked and secured to the first using the optional stacking kit (Fasteners for concrete applications are provided)
- Wiring slots keep cords organized and speed wiring to each bay
- 8-outlet, surge-suppressed power unit
- Ships fully-assembled for quick, simple integration and deployment
- Durable powder coated steel chassis provides a long lasting finish
- Warranted to be free of all defects in materials and workmanship for 10 years, electrical system 2 years
- Designed and assembled in Chippewa Falls, WI, USA

Color Options

<u>Chassis:</u>	<u>Shelves:</u>
 Warm Gray	 Spectrum Blue

Construction

- Metal components consist of 16-gauge steel
- 16-gauge side panels, and sheaves
- All metal components are finished with a scratch-resistant powder coat epoxy
- Each Collectiv8 Charging Pillar is factory-assembled

Specifications

Capacity	8 devices	
Bay capacity (nominal)	<ul style="list-style-type: none"> • 11"W [27.94 cm] x 14.933"D [37.93 cm] x 1.964"H [5 cm] • Max weight per shelf : 5 lb [2.27 kg] 	
Electrical	<ul style="list-style-type: none"> • (8) 120V 3-prong plug outlets • ON / OFF switch (red illuminated) • Power Input: 110-240VAC 	<ul style="list-style-type: none"> • Load capacity: 15A, 1800 watts • 15A replaceable fuse • 8' [243.8 cm] nominal 3-wire IEC power cord
Certifications / Compliance	<ul style="list-style-type: none"> • cUL listed 	<ul style="list-style-type: none"> • Meets or exceeds applicable ANSI-BIFMA test standards
Unit weight (nominal)	27 lb [12.3 kg]	
Shipping weight (nominal)	34 lb [15.4 kg]	

Specifications subject to change without notice

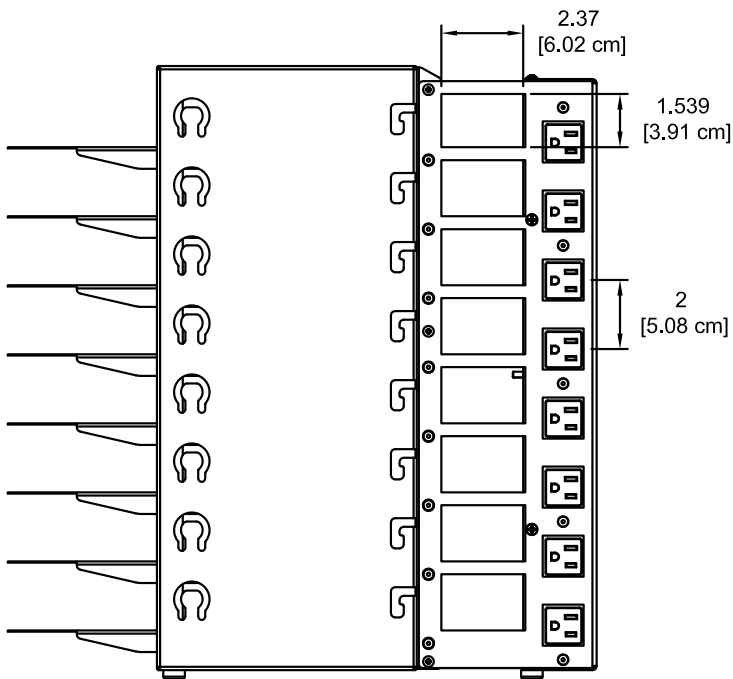

8 power outlets

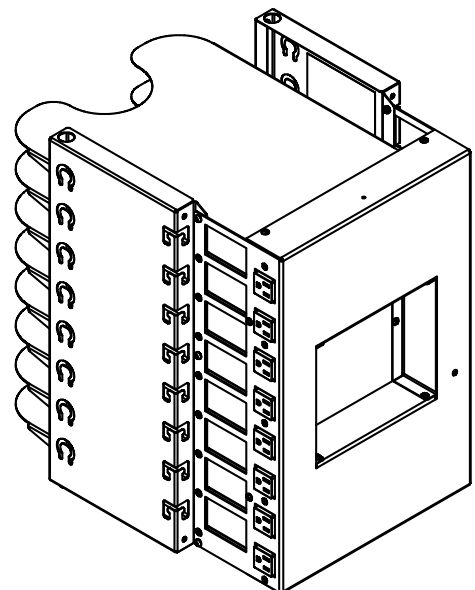
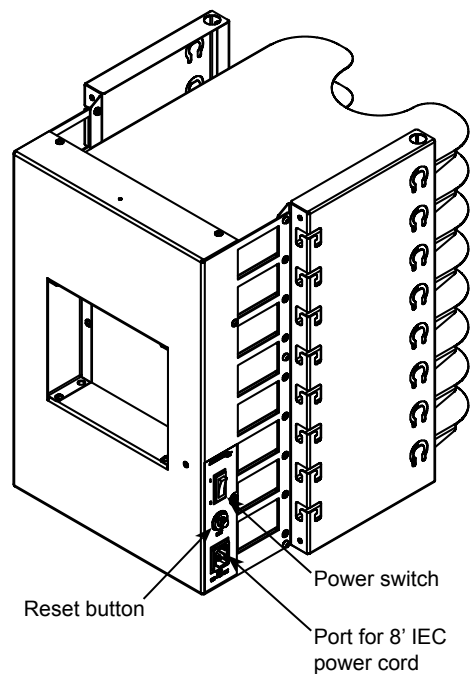

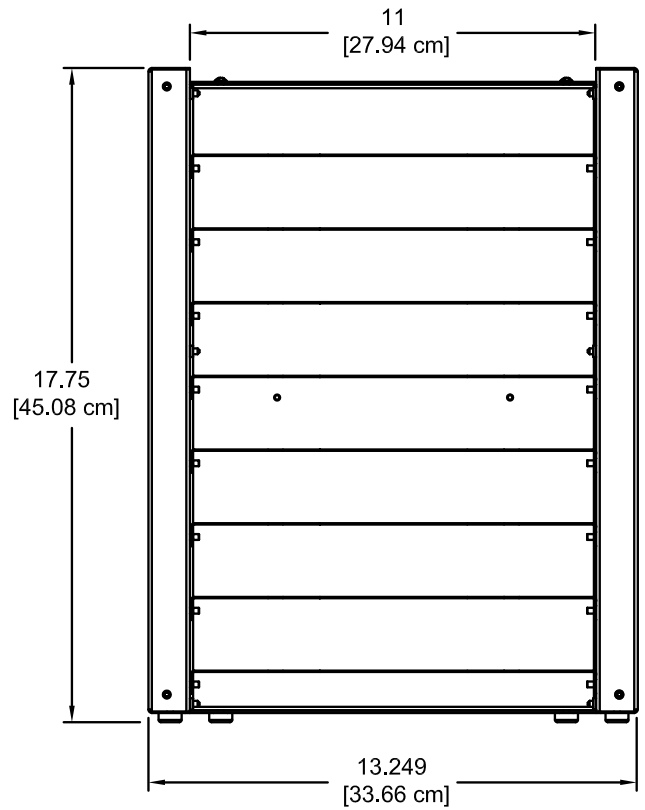
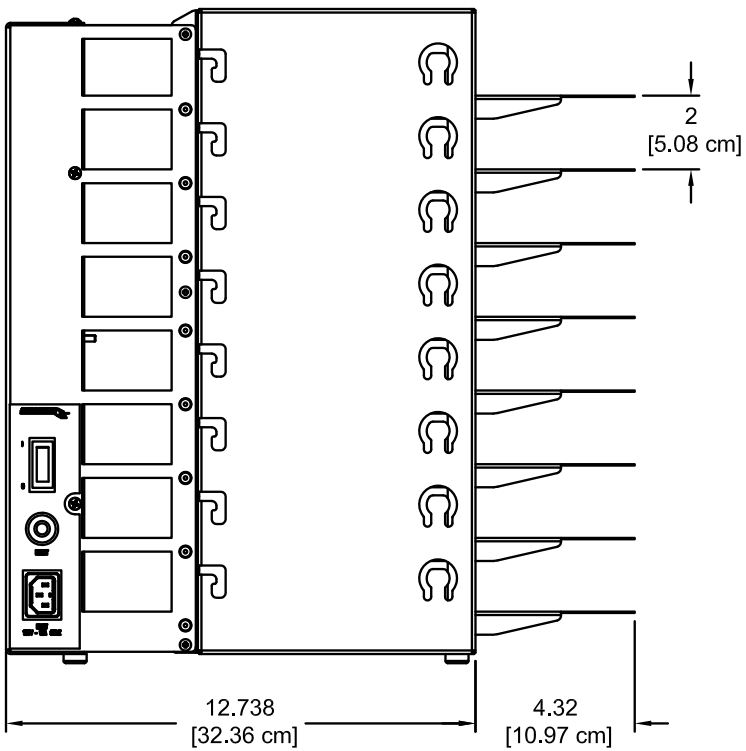
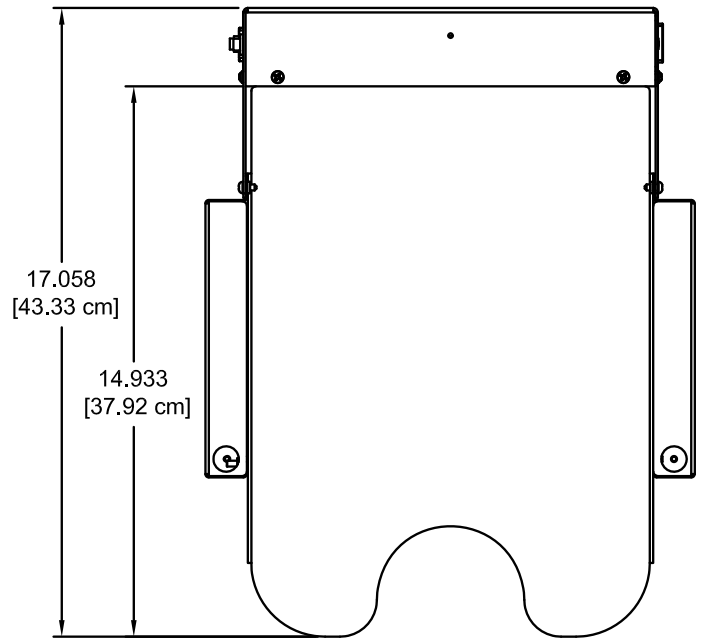
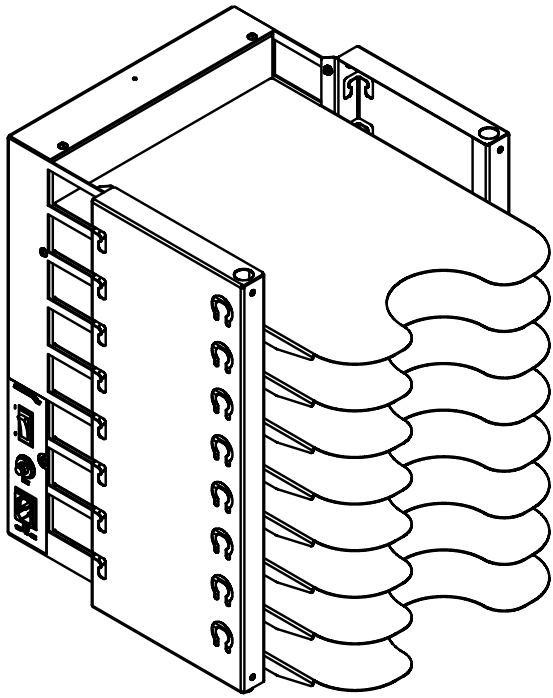

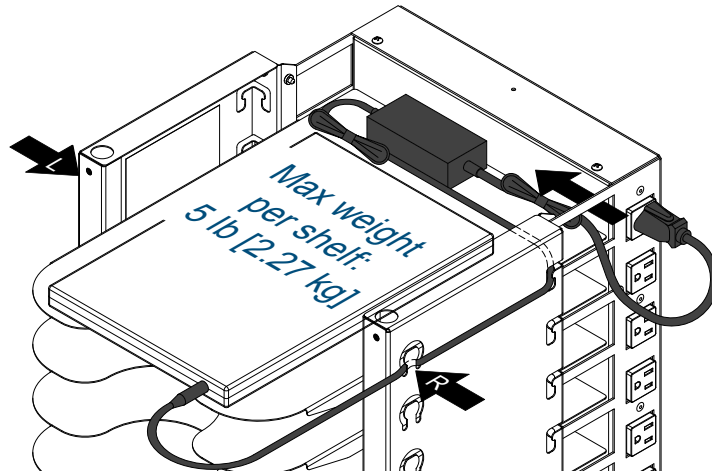

Accessories

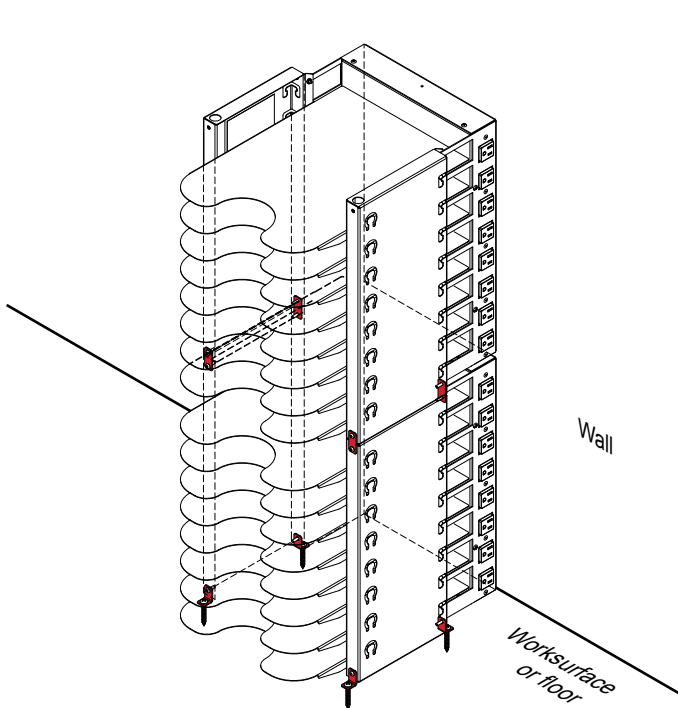

Stacking Kit - 55395

- 55395 Stacking Kit connects two Collectiv8 Charging Pillars together and secures them to a worksurface or floor
- Max recommended stack height: 2 units
- Fasteners included for concrete floor applications

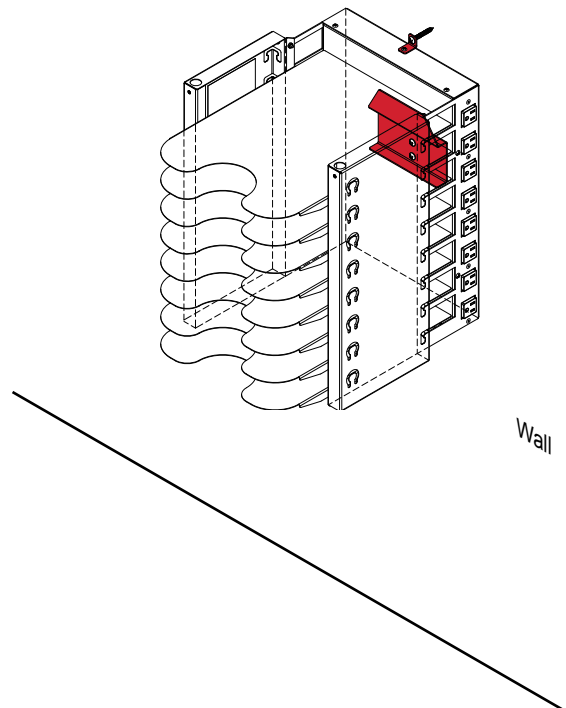

Wall Hanging Kit - 55396

- (1) 55396 kit will attach one unit to a wall
- Fasteners included for concrete wall applications
- To fully comply with ADA guidelines, it's recommended the unit be hung above base cabinets or other permanent structure that extends to the floor

Warranty

WE WILL MAKE IT RIGHT FOR YOU!

Spectrum is committed to provide complete customer satisfaction. Each of our products is manufactured from the best materials available and each product is stringently monitored throughout the production process through our P.A.C.E. program (Product Assurance to meet Customer Expectations).

We expressly warrant that Spectrum products will be of good quality and workmanship and free from defect for the period set out in the warranty table below from the date of delivery. This warranty shall not apply to defects or damage resulting from misuse, abuse, neglect, improper care, modification or repair not authorized by Spectrum, or any other cause outside the control of Spectrum. Spectrum will, at its sole option, either repair or replace the defective product.

This warranty is exclusive; no other warranty, written or oral, is expressed or implied. This warranty is given by Spectrum to Buyer and to no other person or legal entity. No Spectrum dealer, distributor, agent or employee is authorized to make any modification or addition to this warranty.

NOTWITHSTANDING ANYTHING TO THE CONTRARY, SPECTRUM WILL NOT UNDER ANY CIRCUMSTANCES BE LIABLE FOR INDIRECT OR LIQUIDATED DAMAGES, INCLUDING CONSEQUENTIAL, INCIDENTAL AND SPECIAL DAMAGES. IN NO EVENT SHALL SPECTRUM'S LIABILITY, WHETHER UNDER CONTRACT OR WARRANTY, IN TORT OR OTHERWISE, EXCEED THE PURCHASE PRICE RECEIVED BY SPECTRUM FOR THE PRODUCT AT ISSUE AND "RECALL ACTION" EXPENSES. SPECTRUM SHALL NOT BE SUBJECT TO ANY OTHER OBLIGATIONS OR LIABILITIES, WHETHER ARISING OUT OF BREACH OF CONTRACT, WARRANTY, TORT (INCLUDING NEGLIGENCE AND STRICT LIABILITY) OR OTHER THEORIES OF LAW, WITH RESPECT TO PRODUCTS SOLD OR SERVICES RENDERED BY SPECTRUM, OR ANY UNDERTAKINGS, ACTS OR OMISSIONS RELATING THERETO.

Our Customer Service Department is ready to provide immediate attention to any questions, comments or concerns. They are available to answer your calls Monday through Friday from 7 am to 5 pm CST. In addition your product comments or concerns are welcome via e-mail at: spectrum@spectrumfurniture.com.

Warranty Table

Item	Warranty Period effective 1/1/2015
Adjustable Crank / Electric Desk Legs	• 1 Year
Flat Panel Desk Gas Cylinders	
Chairs <ul style="list-style-type: none"> • Adjustable Height Chair Parts – including frames, gas cylinders, wood and plastic parts, control handles, casters • Adjustable Height Chair Upholstery • In-Stock Upholstery • Graded-In Fabrics and Customer Owned Material 	<ul style="list-style-type: none"> • 7 Years • 2 Years • 2 Years • No Warranty
Height Adjustable Columns and Lifts	• 1 Year
General Use Casters	
Electrical (including timers and LINAK actuators)	• 2 Years
Keyboard / Mouse Trays	• 1 Year
Flat Panel Monitor Arms <ul style="list-style-type: none"> • Flat Panel Monitor Arm – General Parts • Flat Panel Monitor Arm – Gas Cylinders 	<ul style="list-style-type: none"> • 5 Years • 2 Years
Desks and Lecterns <ul style="list-style-type: none"> • Computer Desk Chassis • Cart Chassis • Lectern Chassis 	• 10 Years



205 Westwood Ave, Long Branch, NJ 07740
 Phone: 866-94 BOARDS (26273) / (732)-222-1511
 Fax: (732)-222-7088 | E-mail: sales@touchboards.com

