

Assembly Instructions:

To purchase parts or accessories, please contact us at
www.spectrumfurniture.com
 1-800-235-1262
 Thank you for choosing Spectrum products!



(5) 0100167
 8-32 x 1/2" PH thrd ctg
 screw



(2) 026296
 Recessed Bumper
 w/ washer

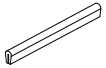

(2) 0109914
 3" edge trim



(2) 037542
 #8 x 5/8" PHSM
 screw

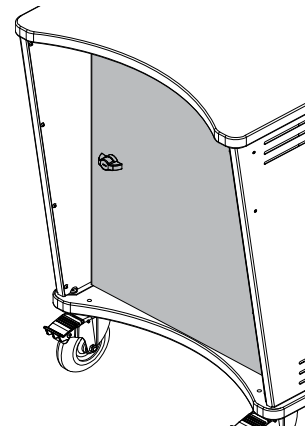

Before you begin, please make sure all parts and proper quantities are included. Any parts damaged during shipment must be reported within 15 days of receipt. To report information regarding damages or if you have any questions, please call 1-800-235-1262.

Instructor-Side Locking Door for Inspiration Lectern #55405

Tools Required:
 Phillips screwdriver

1. Attach Door

- Install the two pieces of edge trim on the lock-side of the door about 1" from the top and bottom as shown in **Figure 1**.
- Align and attach the door to the right side panel mounting holes with (5) 8-32 x 1/2" PH thread cutting screws and tighten securely. **Figure 1**.

Note: If you are using a drill driver, be careful not to over-tighten the screws as this could damage the threads

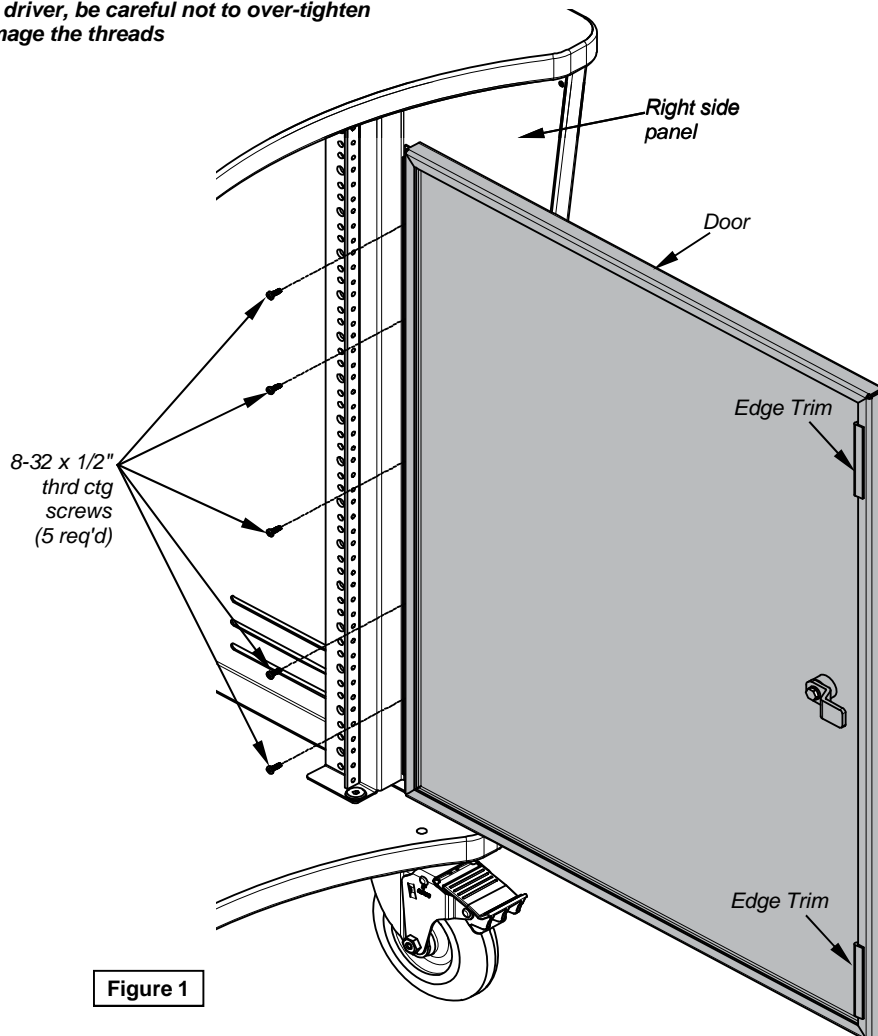

Figure 1

2. Install Door Bumpers

- A. With the door closed, remove the existing upper and lower PHM screws from the right side panel.

Note: On 42"H lecterns, the upper bumper will be installed in the mounting hole 2nd from the top.

- B. Install a bumper in each open mounting hole location with a #8 x 5/8" PHSM screw. **Figure 2.**

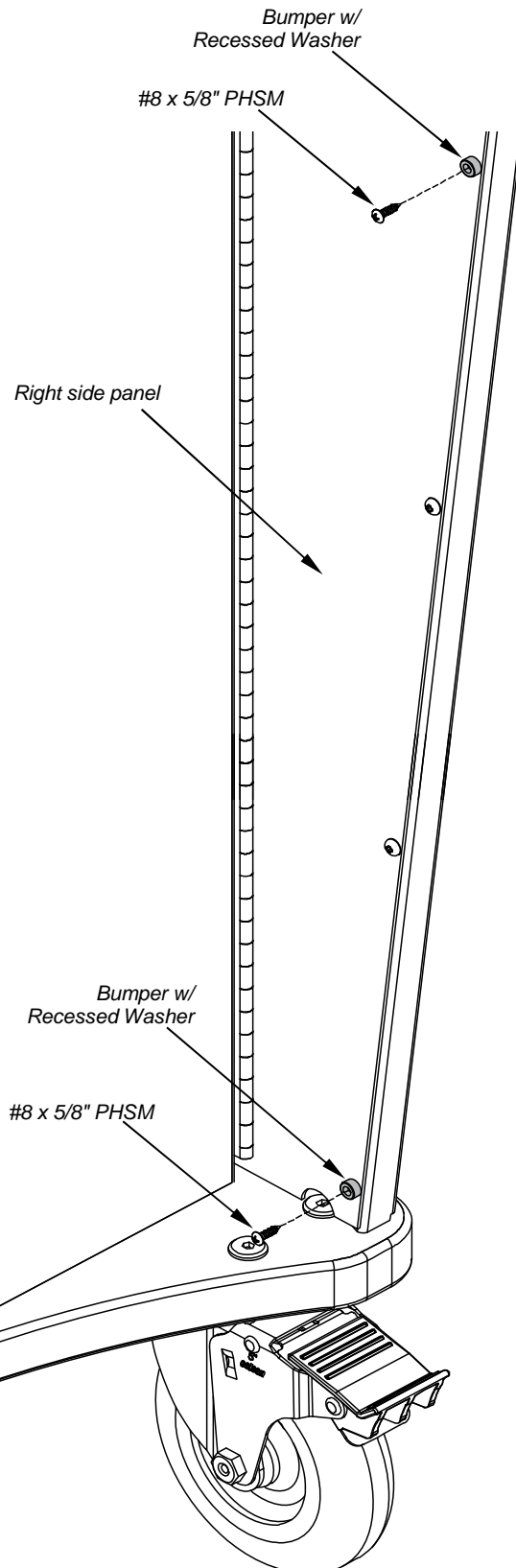

Figure 2

Touchboards

205 Westwood Ave, Long Branch, NJ 07740
Phone: 866-94 BOARDS (26273) / (732)-222-1511
Fax: (732)-222-7088 | E-mail: sales@touchboards.com