

Technical Specifications

55431

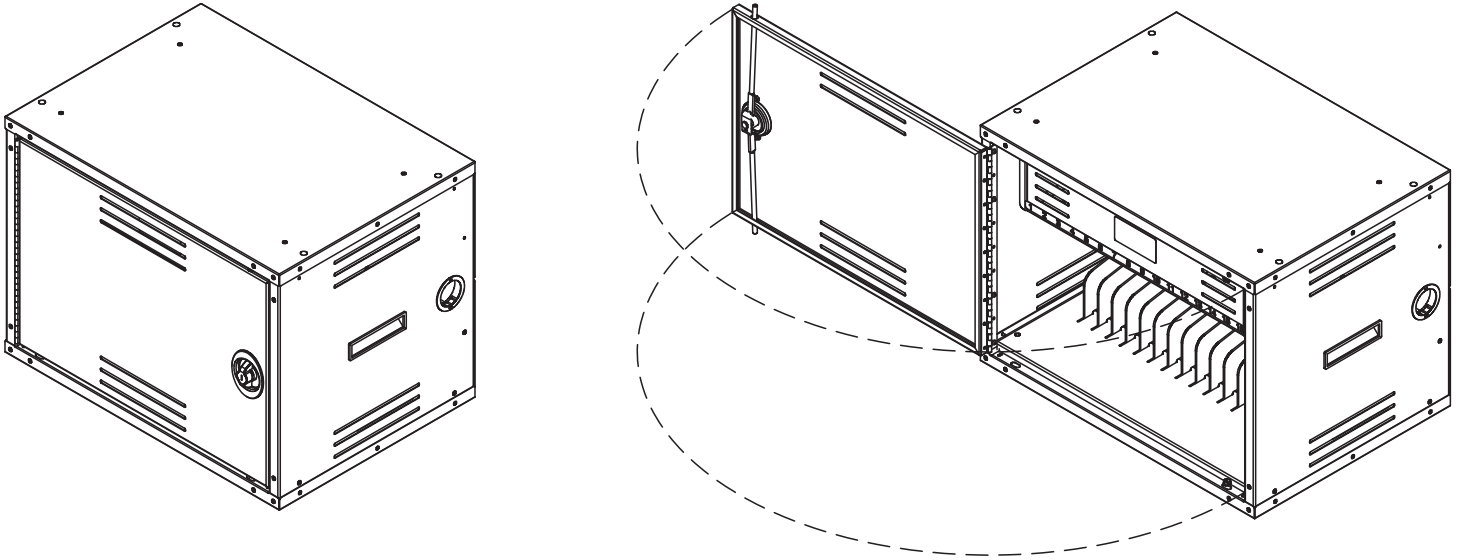

205 Westwood Ave, Long Branch, NJ 07740
Phone: 866-94 BOARDS (26273) / (732)-222-1511
Fax: (732)-222-7088 | E-mail: sales@touchboards.com

Use the InTouch16 Cabinet to store and charge up to 16 computer devices (tablets, Chromebooks and laptops). Padded shelves and flexible dividers protect the computer devices. Overhead wire management in a pullout drawer aids wiring integration, and allows the charging plugs to hang in front of each computing device. The InTouch16 Cabinet's small footprint covers less counter space and can be stacked for additional computer device storage with no additional loss of counter space. The InTouch16 Cabinet is made with powder-coated steel for security and a durable and long-lasting finish. A dual-bolt lock on the door increases security of the computing device.

Features and Benefits

- Manages up to 16 devices (up to 1⁷/₃₂" thick)
- Removable dividers provide the ability to store thicker devices (8 full-size laptops up to 2⁹/₁₆" thick)
- Power drawer provides easy-access to electrical power while keeping line voltage, wiring, and cords away from students
- Superior overhead cord management system keeps charge cords organized at each storage slot (tablet power cords should be 3' or longer)
- Numbered storage slots keep tablets organized
- Ample clearance is provided for easy removal and insertion of tablets
- Durable plastic dividers and padded shelf protect tablets from damage
- Side grommets placed for effective cord management
- Unit can be mounted to a worksurface for additional security
- Ventilated door and side panels help dissipate heat
- Durable powder coated steel chassis provides a long lasting finish
- Double-bolt, keyed locking door provides security and easy-access
- Symmetrical door can be installed to be hinged from the left or right-side
- Electrical system consists of UL-listed components
- Two 10-outlet 120V power strips with 3600 joule surge suppressor
- Power units with generous outlet spacing accommodate a variety of large power plugs
- Warranted to be free of all defects in materials and workmanship with a 10-year warranty. Electrical system 1-year

Page 8

Options

Color Options

Standard metal colors

Silver Sparkle
(S)



Standard color combination refers to the quickest deliverable product color combination. Custom laminates and color combinations are available-additional lead-times and up-charges may apply. Call 1-800-235-1262 for further information.

Construction

- Metal components consist of 16-gauge steel
- Vented side panels and door are made of 16-gauge steel
- All metal components are finished with a scratch-resistant powder coat epoxy
- Each InTouch16 Cabinet is factory-assembled

Specifications

Capacity	16 units 8 units (every other divider removed to provide space for thicker laptops)
Storage slots	1 $\frac{7}{32}$ "W x 17 $\frac{3}{8}$ "D x 12"H - (16 tablets) 2 $\frac{9}{16}$ "W x 17 $\frac{3}{8}$ "D x 12"H - (8 full-size laptops)
Stacking	up to 3 high Caution: Must be bolted together and top unit bolted to wall for stability.
Power drawer	20 $\frac{9}{16}$ "W x 16"D x 5 $\frac{1}{16}$ "H
Electrical	Two 10-outlet, 110V/120V, 15A, power strips, each with 3600 joule surge suppressor, on/off rocker switch, and 8' nominal, 8' 3-wire power cord. UL-listed.
Unit weight (nominal)	75 lbs
Shipping weight (nominal)	90 lbs
Meets or exceeds applicable ANSI-BIFMA test standards	

Specifications subject to change without notice

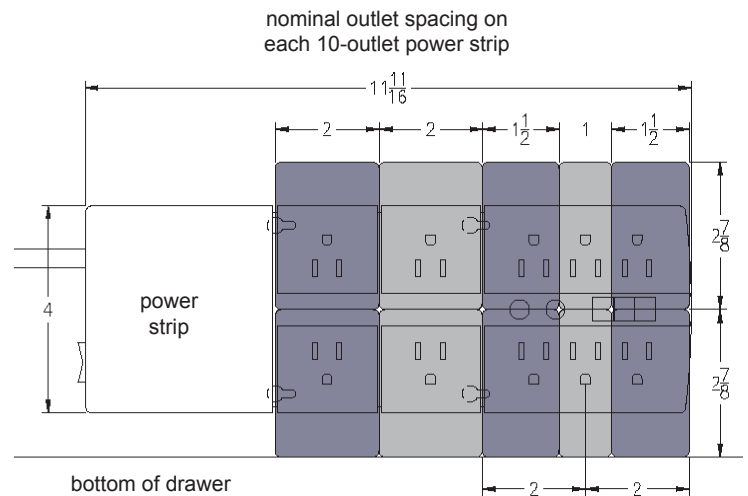
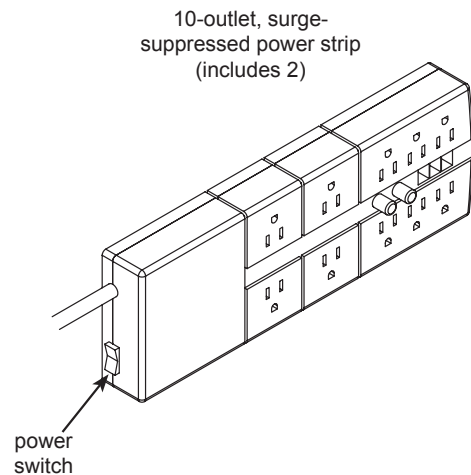
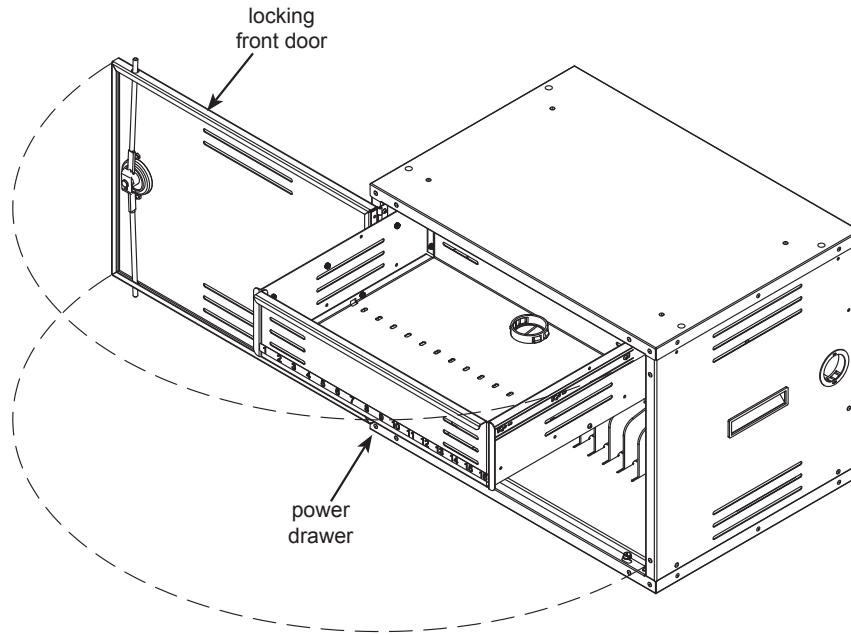

InTouch16 Cabinet

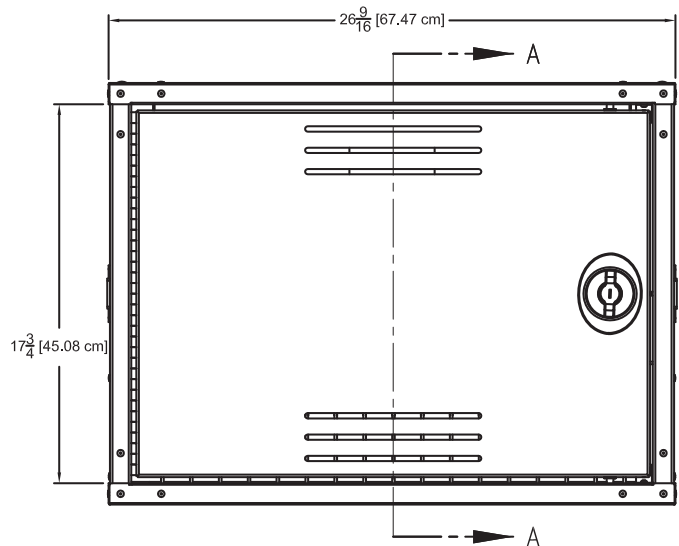
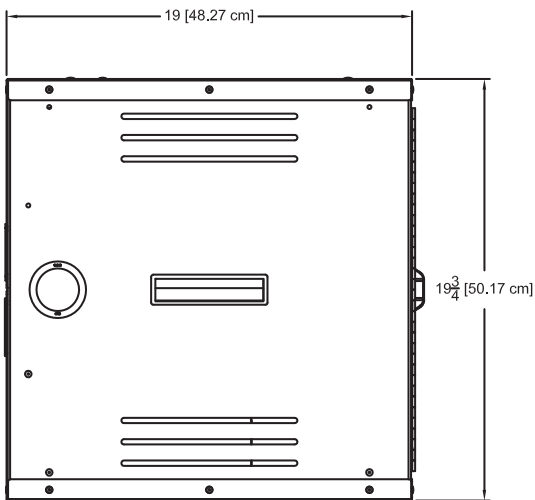
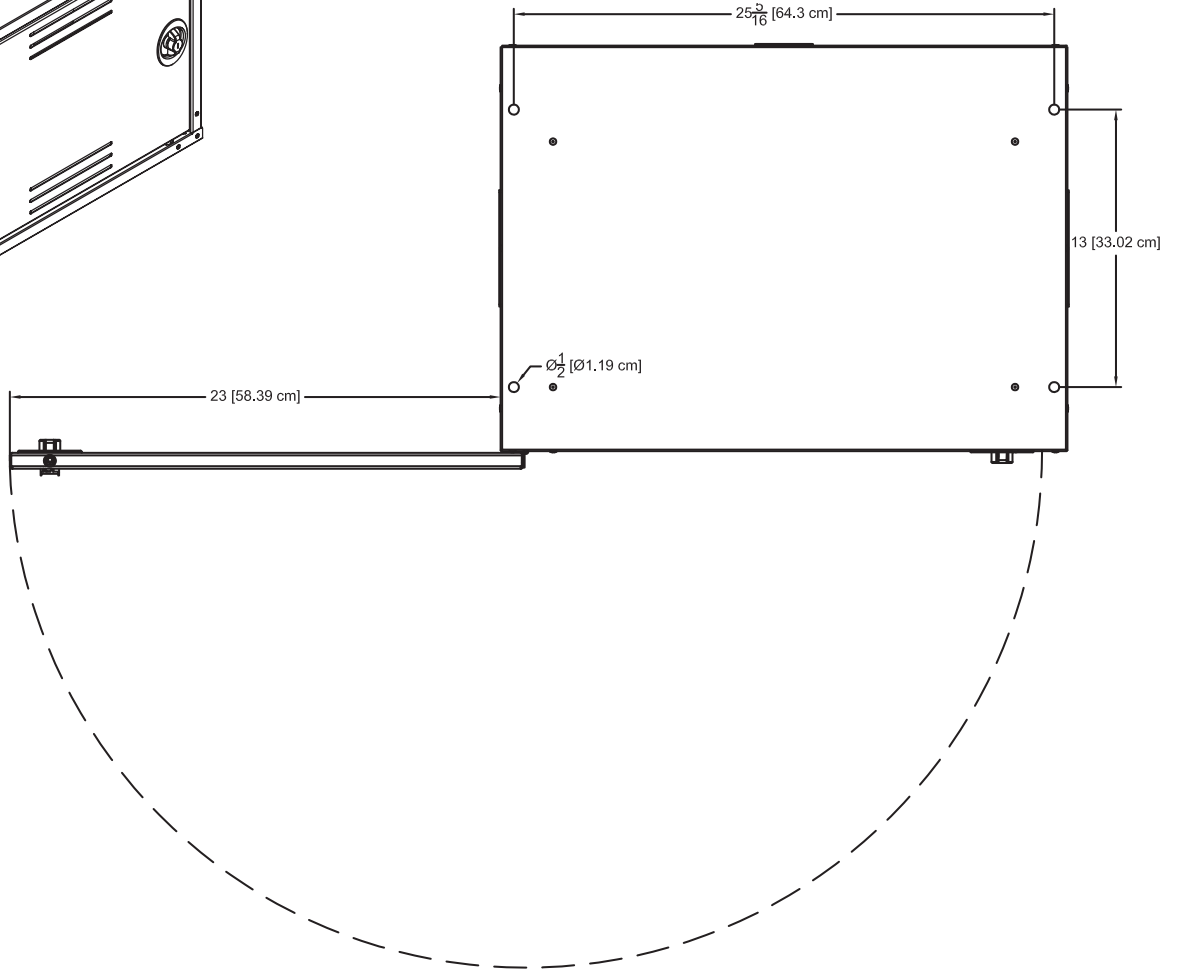
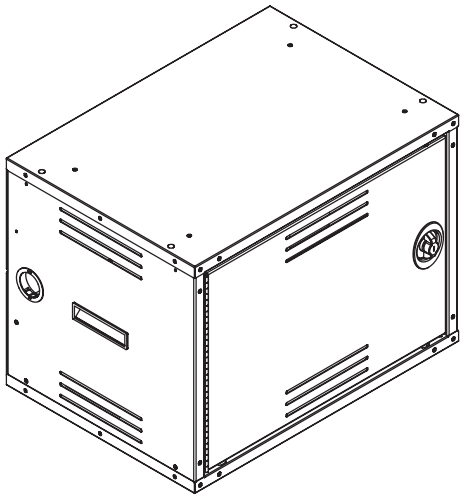

section view

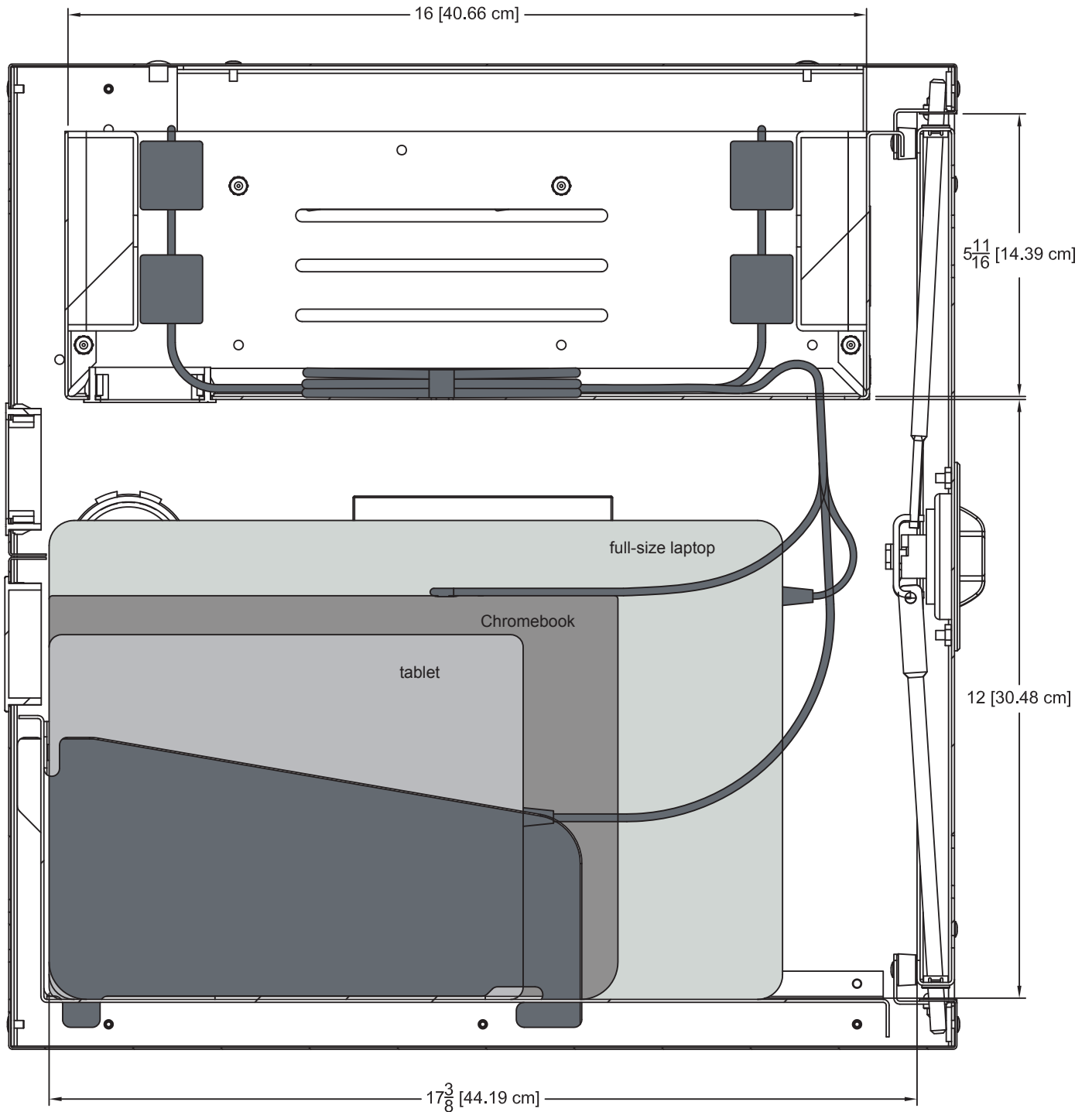

Touchboards

205 Westwood Ave, Long Branch, NJ 07740
Phone: 866-94 BOARDS (26273) / (732)-222-1511
Fax: (732)-222-7088 | E-mail: sales@touchboards.com

front view with tablets
(shown without door)

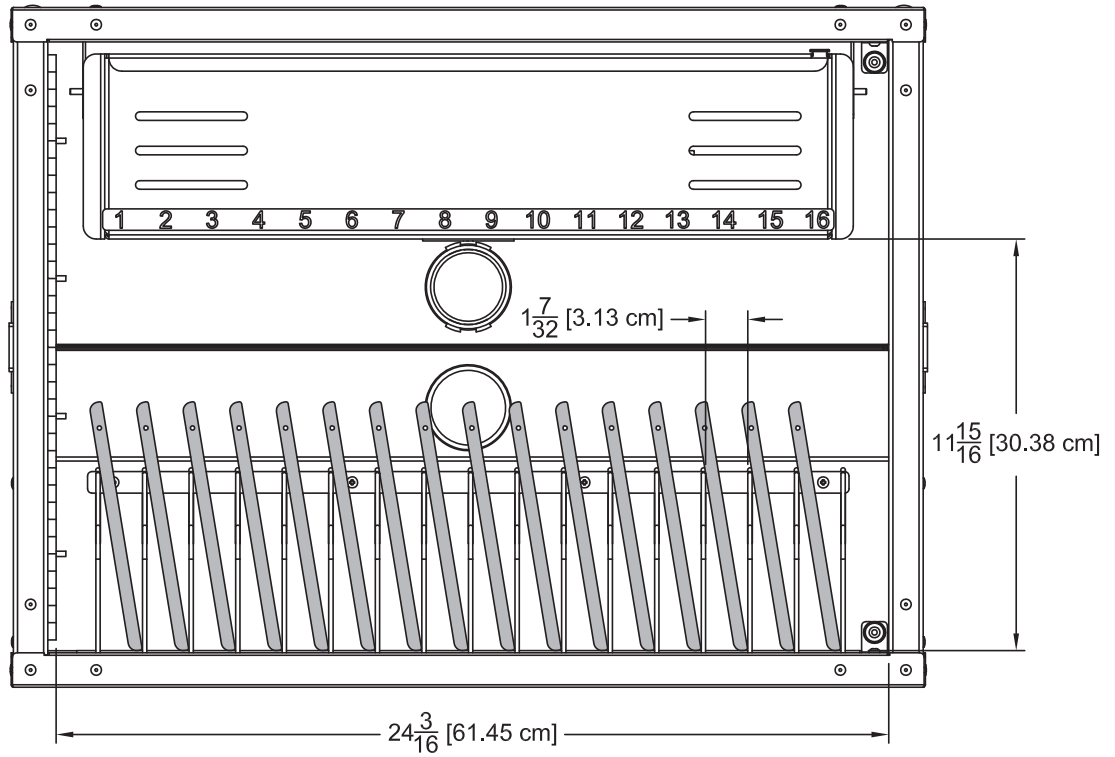

front view with laptops
(8 dividers removed)
(shown without door)

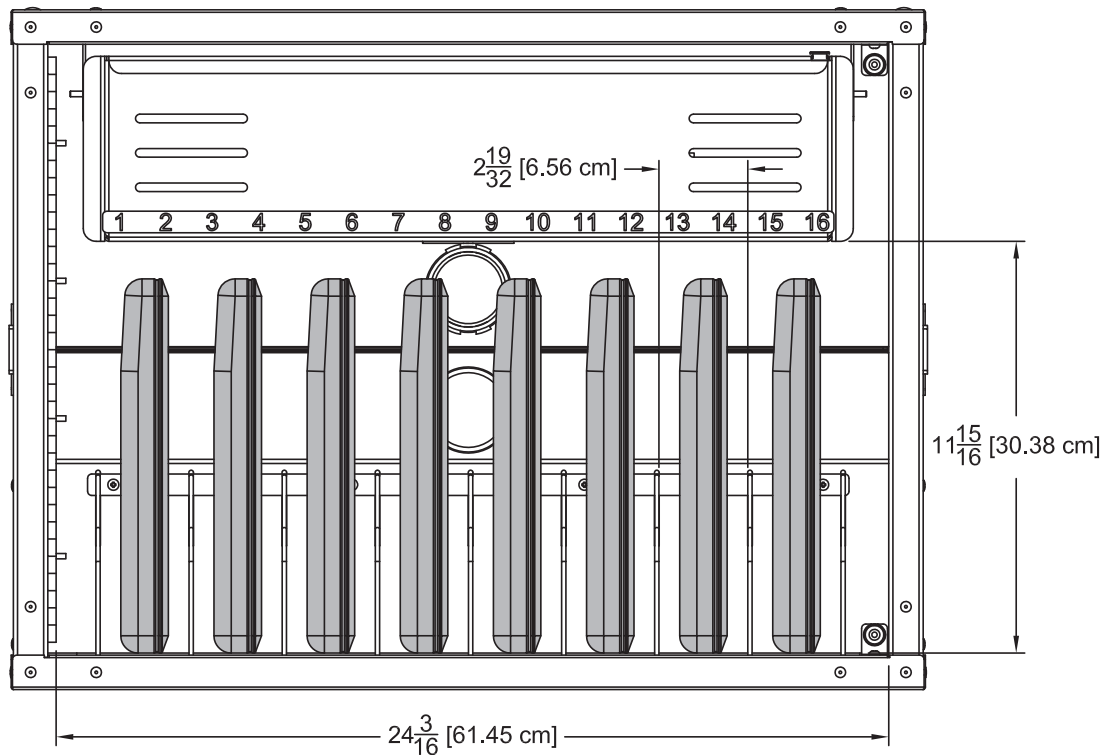

internal drawer dimensions

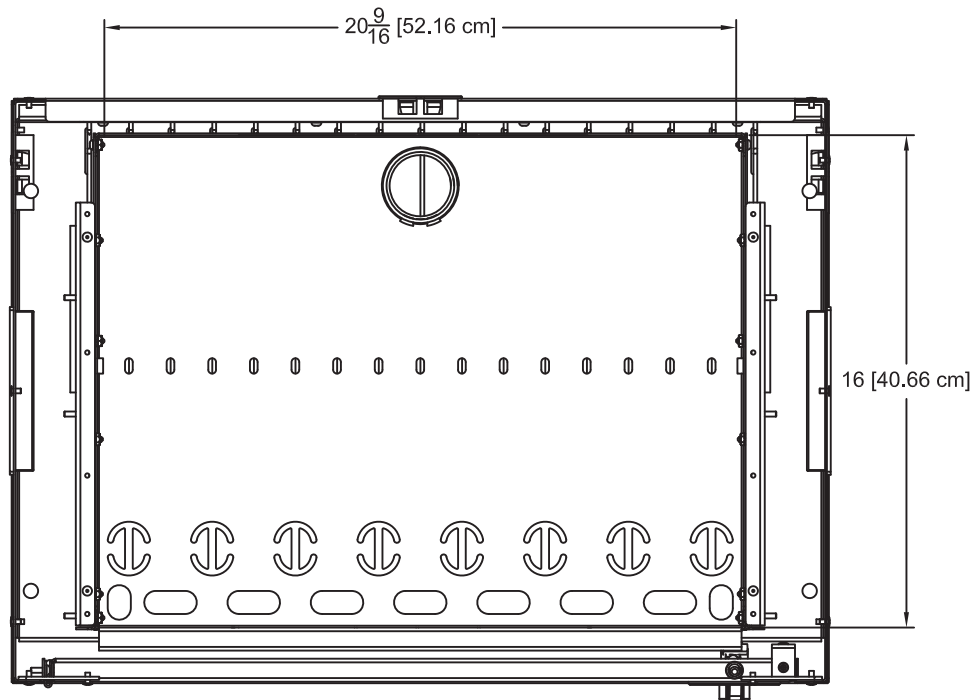
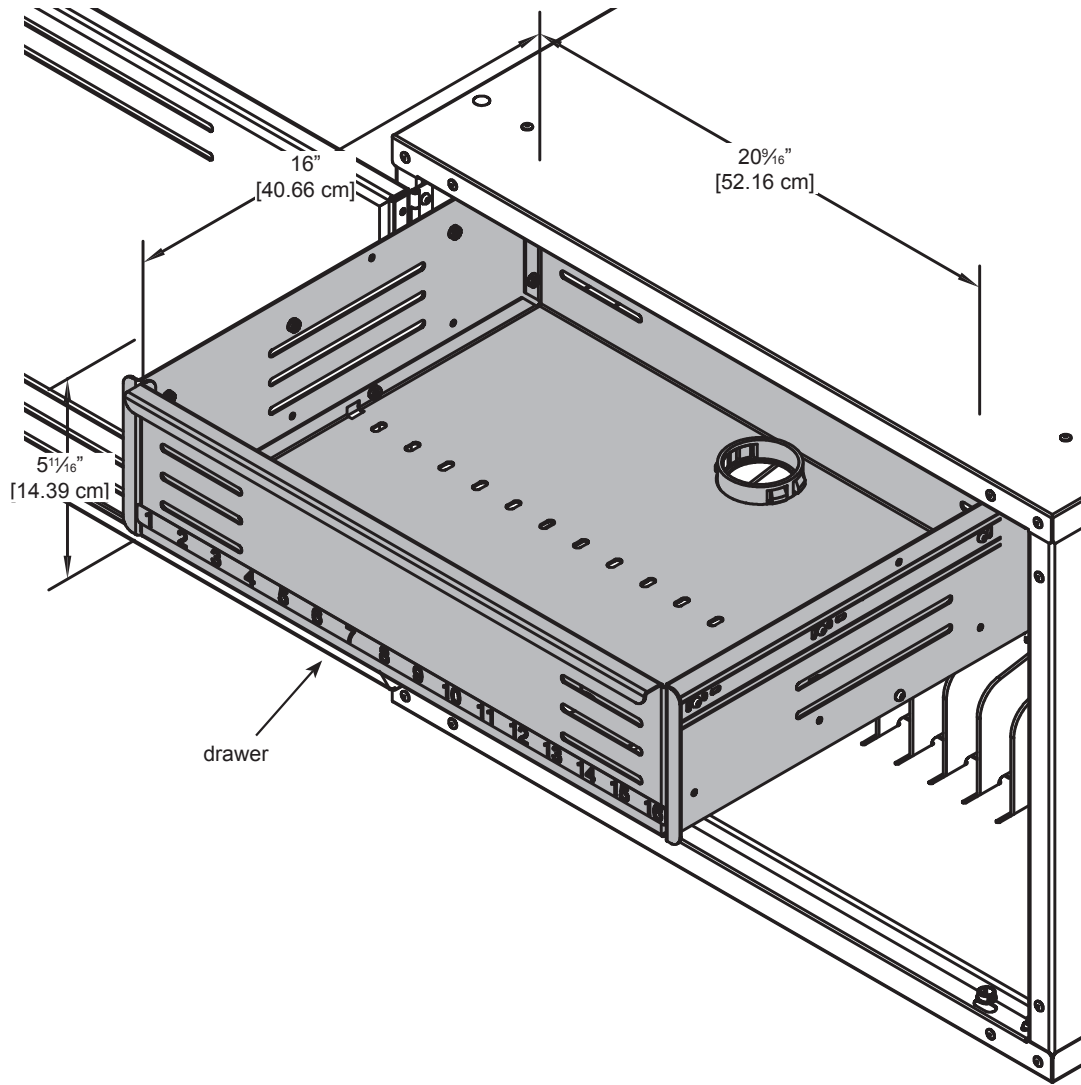

power strip mounting options

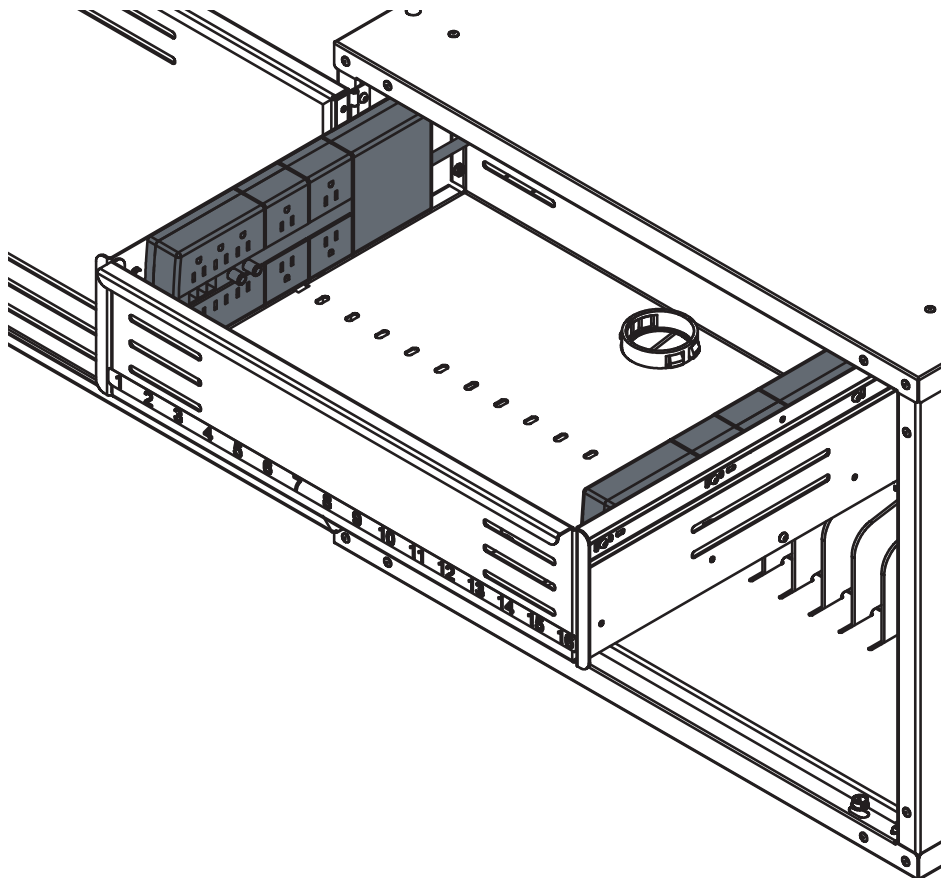
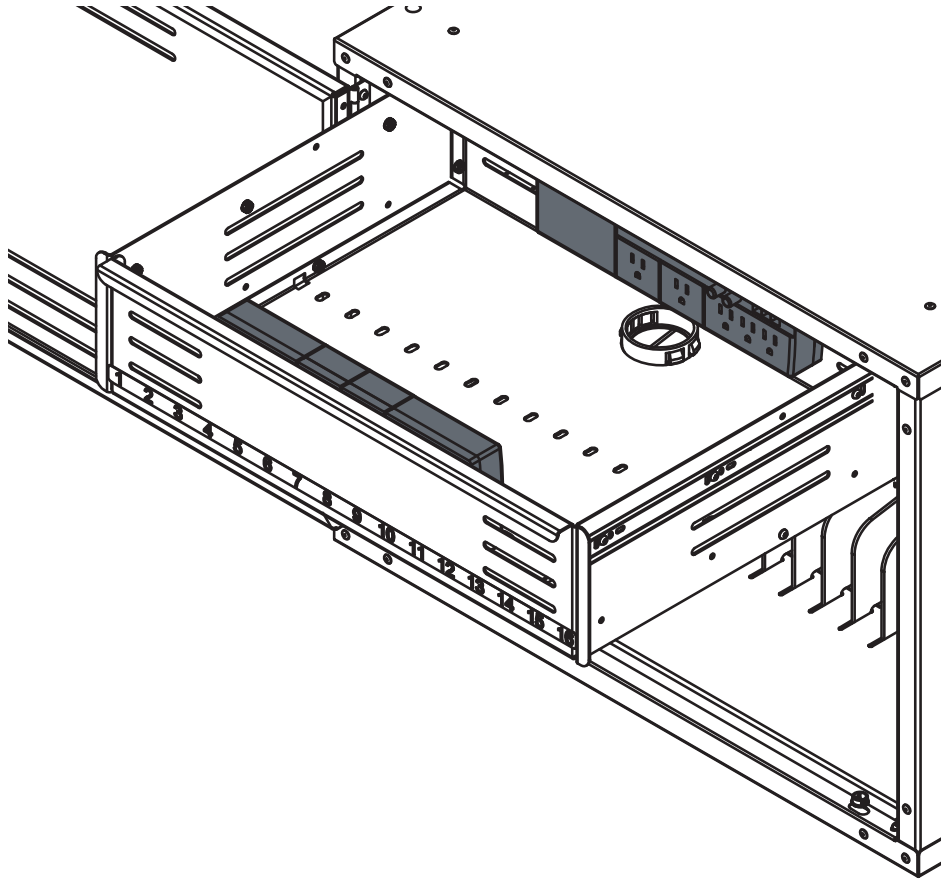

⚠ WARNING ⚠

THE INTOUCH 16 CABINET CAN BE STACKED ON A STABLE SURFACE (UP TO 3 HIGH). THE INTOUCH 16 CABINET IS NOT INTENDED OR DESIGNED TO BE INDIVIDUALLY HUNG ON A WALL.

WHEN STACKING, THE UNITS MUST BE STABILIZED USING THE 3/8" MOUNTING HOLES IN THE BACK PANEL, AND BOLTED TOGETHER USING THE 1/2" MOUNTING HOLES IN THE TOP AND BOTTOM PANELS. FASTENERS ARE NOT INCLUDED.

IT IS THE CUSTOMER'S RESPONSIBILITY TO USE ADEQUATE FASTENERS DESIGNED FOR THE SPECIFIC WORKSURFACE, FLOOR, OR WALL TYPE THE UNIT WILL BE MOUNTED TO.

Note: The 3/8" mounting holes located on the back panel are for stabilizing the unit(s) (up to 3 high only) and are 16" on-center to match most wall construction stud spacing. Be sure fasteners are anchored securely to studs or other solid portion of the wall.

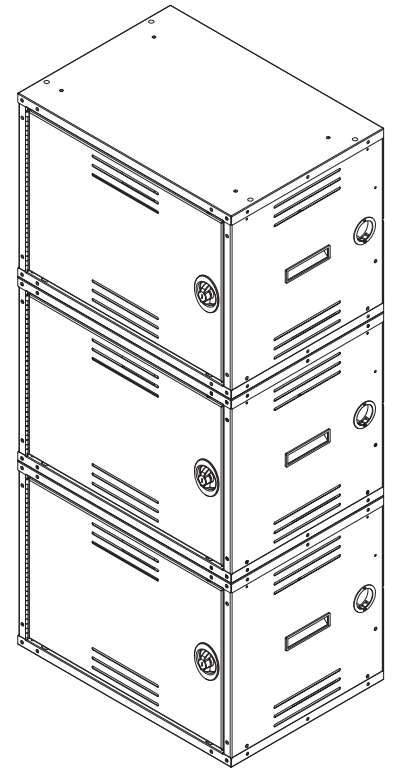

back view

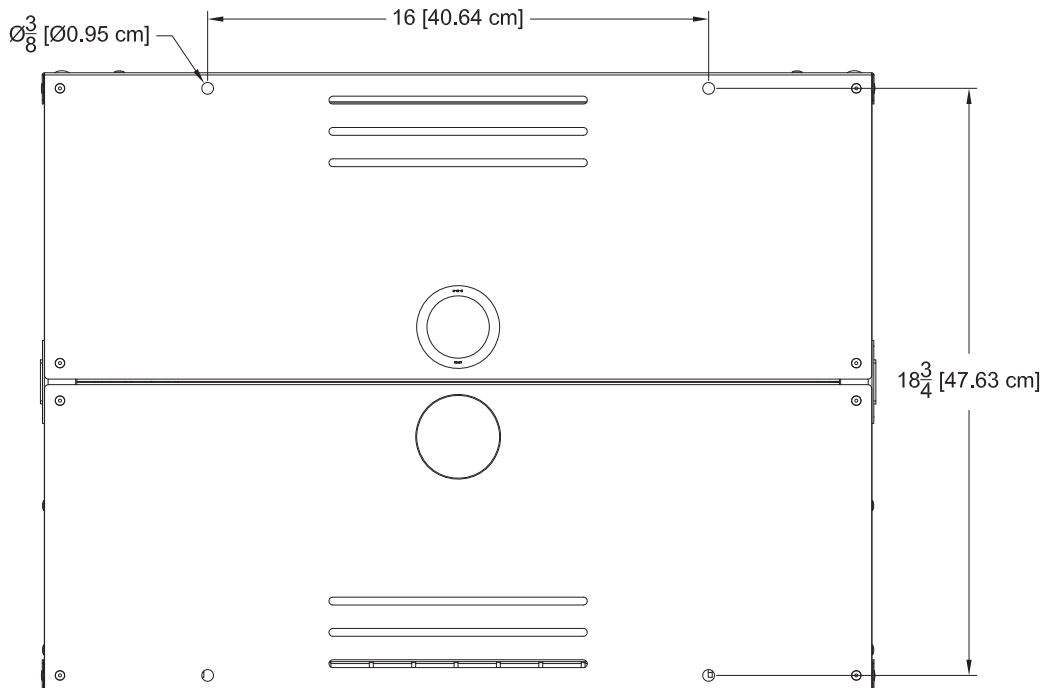

Options

- Velcro® strap kit
(16) 3/4" x 12", and (32) 3/4" x 5"
Velcro® straps
95004

Warranty

WE WILL MAKE IT RIGHT FOR YOU!

Spectrum is committed to provide complete customer satisfaction. Each of our products is manufactured from the best materials available and each product is stringently monitored throughout the production process through our P.A.C.E. program (Product Assurance to meet Customer Expectations).

We expressly warrant that Spectrum products will be of good quality and workmanship and free from defect for the period set out in the warranty table below from the date of delivery. This warranty shall not apply to defects or damage resulting from misuse, abuse, neglect, improper care, modification or repair not authorized by Spectrum, or any other cause outside the control of Spectrum. Spectrum will, at its sole option, either repair or replace the defective product.

This warranty is exclusive; no other warranty, written or oral, is expressed or implied. This warranty is given by Spectrum to Buyer and to no other person or legal entity. No Spectrum dealer, distributor, agent or employee is authorized to make any modification or addition to this warranty.

NOTWITHSTANDING ANYTHING TO THE CONTRARY, SPECTRUM WILL NOT UNDER ANY CIRCUMSTANCES BE LIABLE FOR INDIRECT OR LIQUIDATED DAMAGES, INCLUDING CONSEQUENTIAL, INCIDENTAL AND SPECIAL DAMAGES. IN NO EVENT SHALL SPECTRUM'S LIABILITY, WHETHER UNDER CONTRACT OR WARRANTY, IN TORT OR OTHERWISE, EXCEED THE PURCHASE PRICE RECEIVED BY SPECTRUM FOR THE PRODUCT AT ISSUE AND "RECALL ACTION" EXPENSES. SPECTRUM SHALL NOT BE SUBJECT TO ANY OTHER OBLIGATIONS OR LIABILITIES, WHETHER ARISING OUT OF BREACH OF CONTRACT, WARRANTY, TORT (INCLUDING NEGLIGENCE AND STRICT LIABILITY) OR OTHER THEORIES OF LAW, WITH RESPECT TO PRODUCTS SOLD OR SERVICES RENDERED BY SPECTRUM, OR ANY UNDERTAKINGS, ACTS OR OMISSIONS RELATING THERETO.

Our Customer Service Department is ready to provide immediate attention to any questions, comments or concerns. They are available to answer your calls Monday through Friday from 7 am to 5 pm CST. In addition your product comments or concerns are welcome via e-mail at: spectrum@spectrumfurniture.com.

Warranty Table

Item	Warranty Period
• Adjustable Crank/Electric Desk Legs	• 1 Year
• Flat Panel Desk Gas Cylinders	
• Adjustable Height Chair Parts – including frames, gas cylinders, wood and plastic parts, and control handles Adjustable Height Chair Parts Casters	• 7 Years
• Adjustable Height Chair Upholstery	• 2 Years
• In-Stock Upholstery	• 2 Years
• Graded-In Fabrics and Customer Owned Material	• No Warranty
• Height Adjustable Columns and Lifts	• 1 Year
• General Use Casters	
• Electrical	
• Keyboard/Mouse Trays	
• Flat Panel Monitor Arm – General Parts	• 5 Years
• Flat Panel Monitor Arm – Gas Cylinders	• 2 Years
• Computer Desk Chassis	• 10 Years
• Cart Chassis	
• Lectern Chassis	



205 Westwood Ave, Long Branch, NJ 07740
 Phone: 866-94 BOARDS (26273) / (732)-222-1511
 Fax: (732)-222-7088 | E-mail: sales@touchboards.com

