

## Technical Specifications

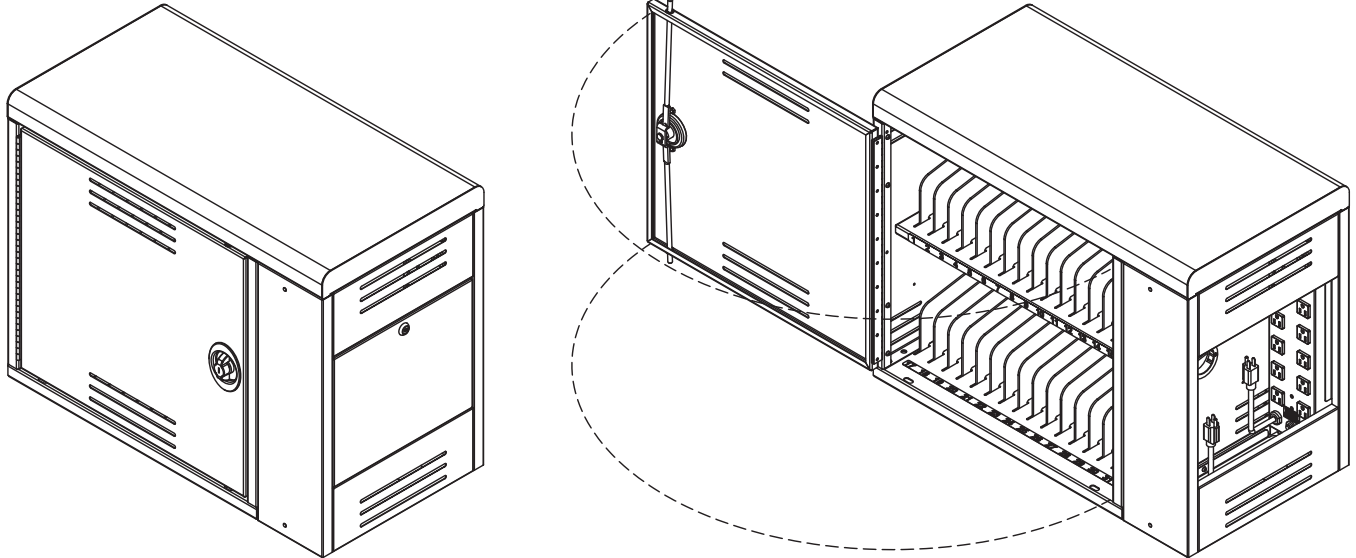

55434

205 Westwood Ave, Long Branch, NJ 07740  
Phone: 866-94 BOARDS (26273) / (732)-222-1511  
Fax: (732)-222-7088 | E-mail: sales@touchboards.com



The InTouch 32 Secure Tablet Locker was developed directly from our customers' requests to individually manage their 1:1 tablet programs and keep the devices safe and secure within the classroom. The large capacity of the IT32 allows instructors to more easily manage the entire tablet inventory in one location. Careful consideration is given to cord management by having a charging plug in front of every bay for easy tablet organization.

The IT32 Locker secures tablets with Spectrum's custom 2-point double-bolt lock. There are no plastic structure pieces to be pried open – the IT32 exterior consists of 16 gauge steel. Further protective measures can be taken by bolting the IT32 to either a wall or worksurface. Safety measures are designed into the electrical system as well with all outlets located in a separately locked module.

For the ultimate in 1:1 device security and organization, look no further than Spectrum's InTouch32 Secure Tablet Locker!

## Features and Benefits

- Manages up to 32 tablet computers including iPads® (up to 1¼" thick)
- Access panel provides easy-access to electrical power while keeping all line voltage, wiring, and cords away from students
- Superior overhead cord management system keeps charge cords organized at each storage slot (tablet power cords should be 3' or longer)
- Numbered storage slots keep tablets organized
- Ample clearance is provided for easy removal and insertion of tablets
- Durable plastic dividers protect tablets from damage
- Side grommets placed for effective cord management
- Unit can be mounted to a worksurface for additional security
- Door and side panels are effectively ventilated to keep tablets cool
- Durable powder coated steel chassis provides a long lasting finish
- Double-bolt, keyed locking door provide security and easy-access
- Electrical system consists of UL-listed components
- Two 16-outlet power units with 15-amp breaker and reset button
- Power units with generous outlet spacing accommodate a variety of large power plugs
- Warranted to be free of all defects in materials and workmanship with a 10-year warranty. Electrical system 1-year

### Color Options

Standard metal colors

Cool White  
(CW)



Standard color combination refers to the quickest deliverable product color combination.

# Construction

- Metal components consist of 16-gauge steel
- Vented side panels and door are made of 16-gauge steel
- All metal components are finished with a scratch-resistant powder coat epoxy
- Each InTouch 32 Secure Tablet Locker is factory-assembled

# Specifications

Capacity	32 tablets
Storage slots	1¼"W x 12⅝"D x 9¾"H
Electrical	The locker has two power units each with 16 grounded 120V outlets with a 15-amp circuit breaker, on/off rocker switch, and 15' nominal, 3-wire, 14 AWG, UL-listed power cord
Unit weight (nominal)	76 lbs
Shipping weight (nominal)	85 lbs
Meets or exceeds applicable ANSI-BIFMA test standards	

Specifications subject to change without notice

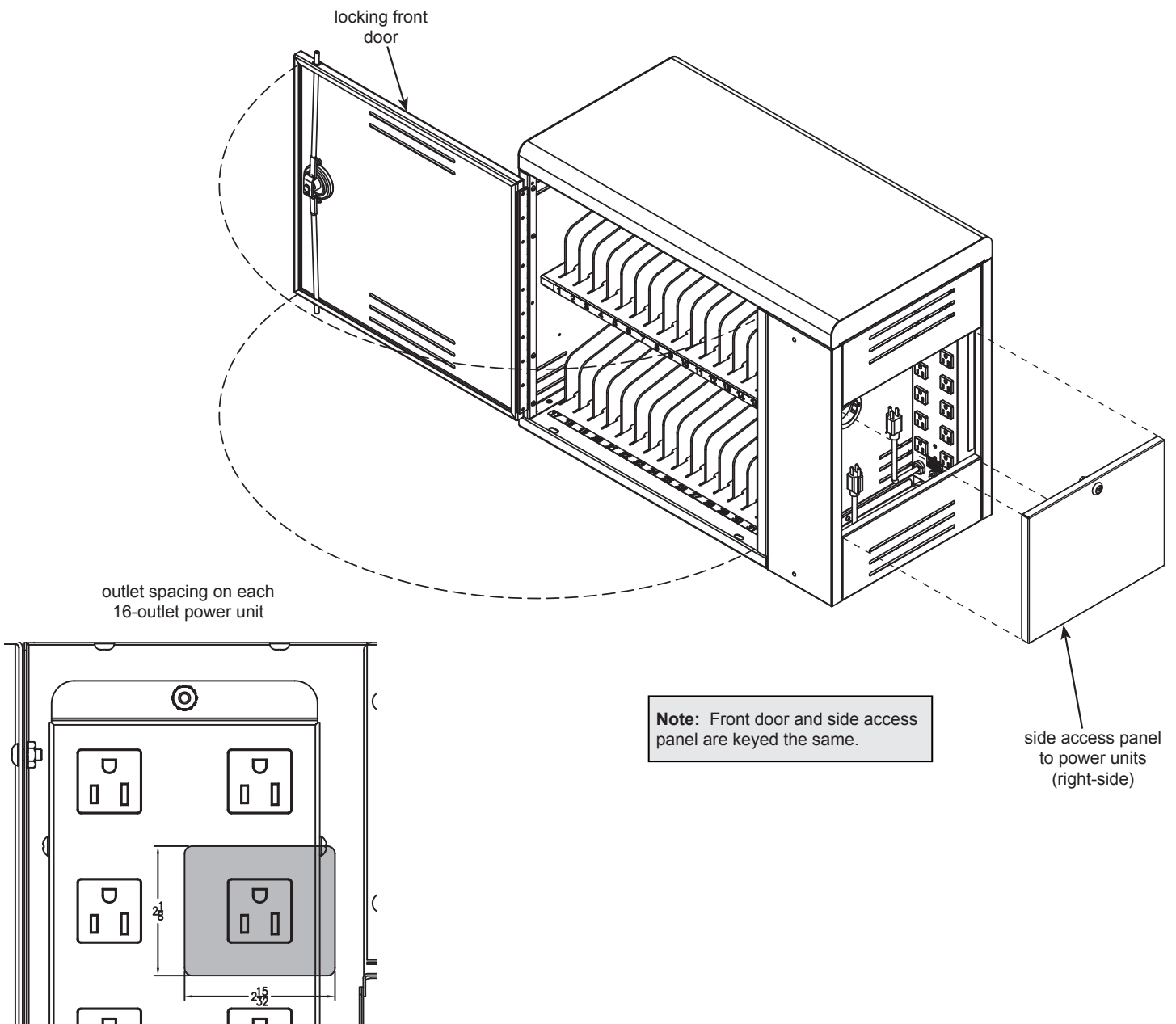



205 Westwood Ave, Long Branch, NJ 07740  
Phone: 866-94 BOARDS (26273) / (732)-222-1511  
Fax: (732)-222-7088 | E-mail: sales@touchboards.com

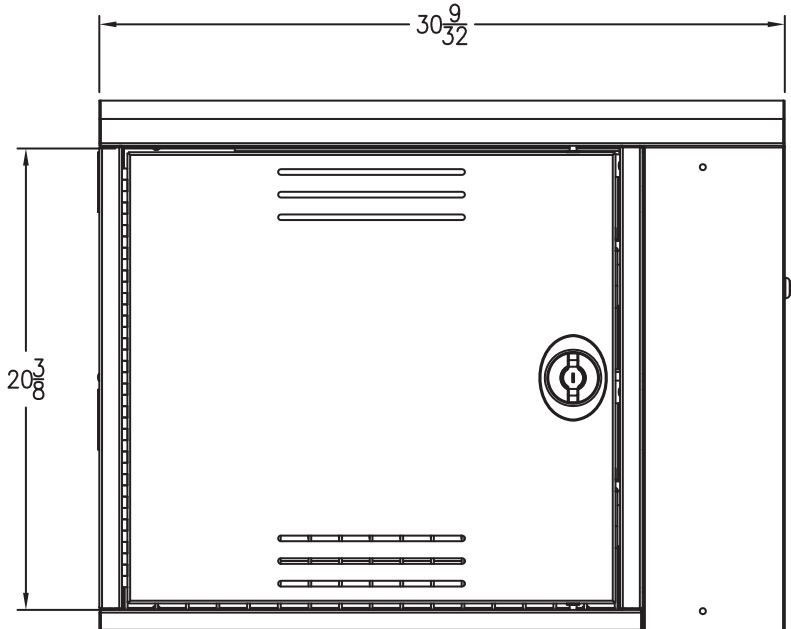
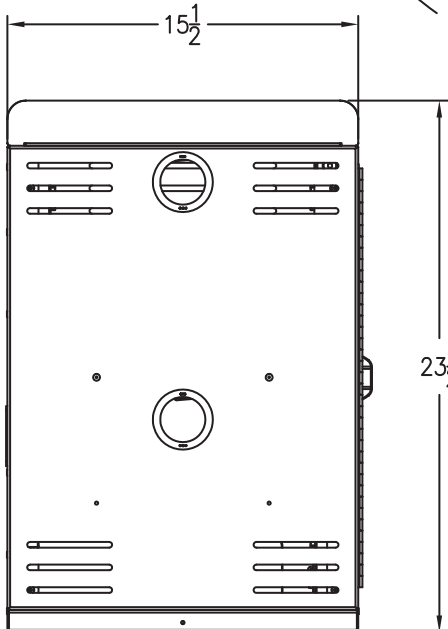
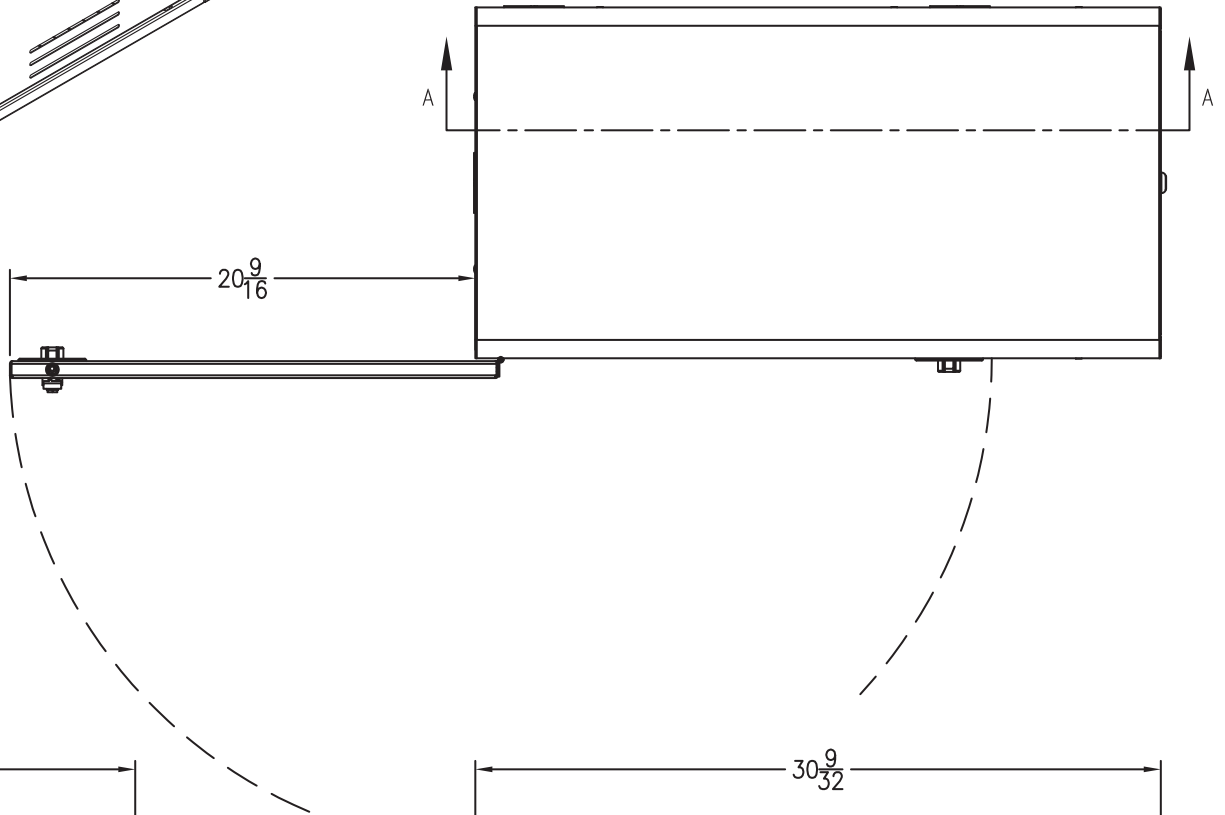
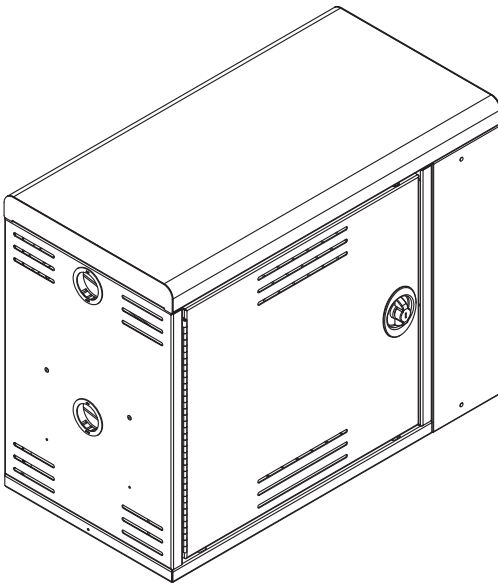

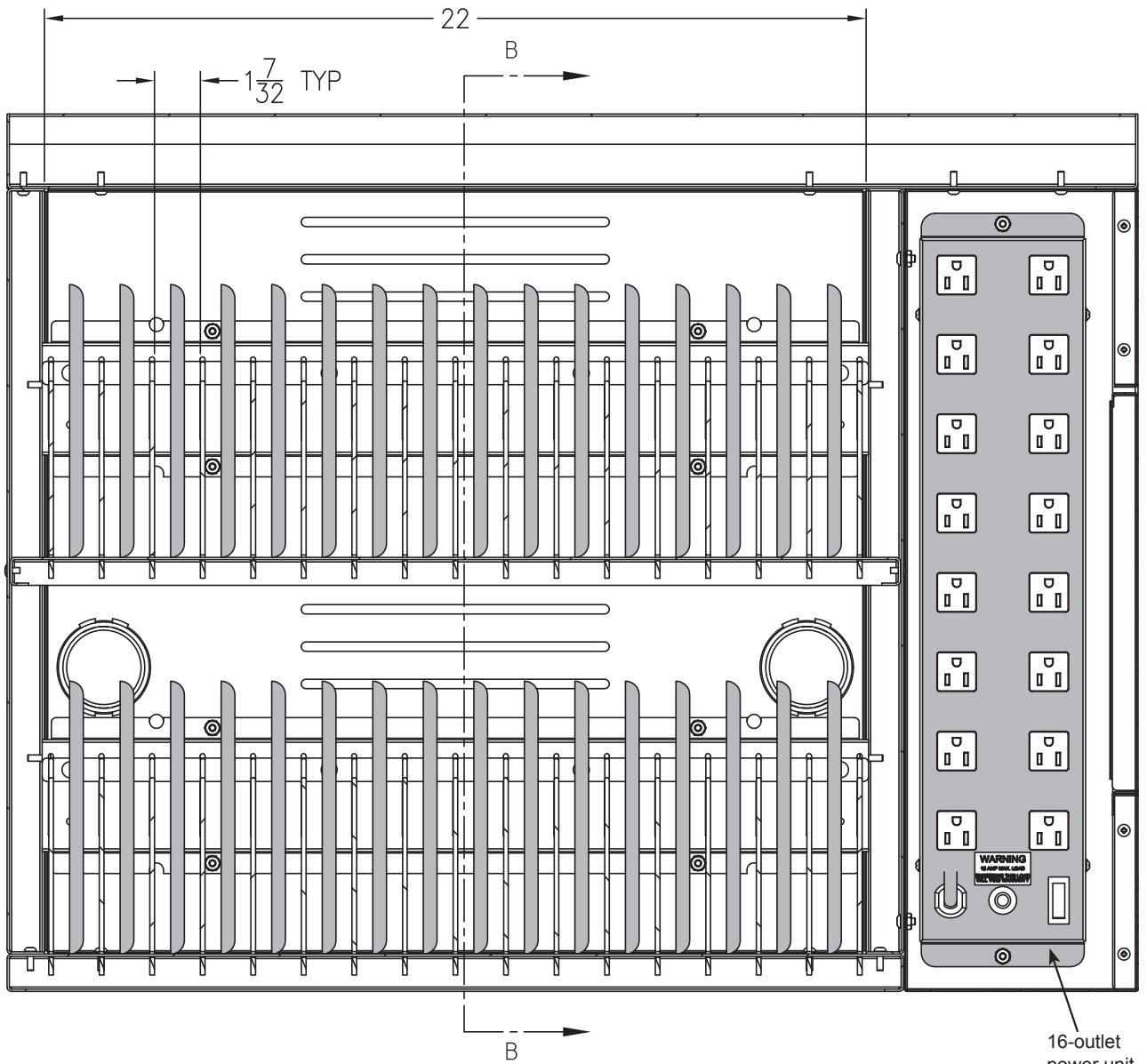

SECTION A-A

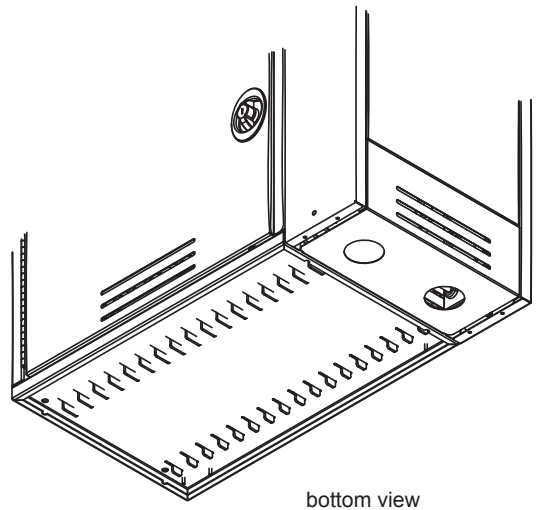
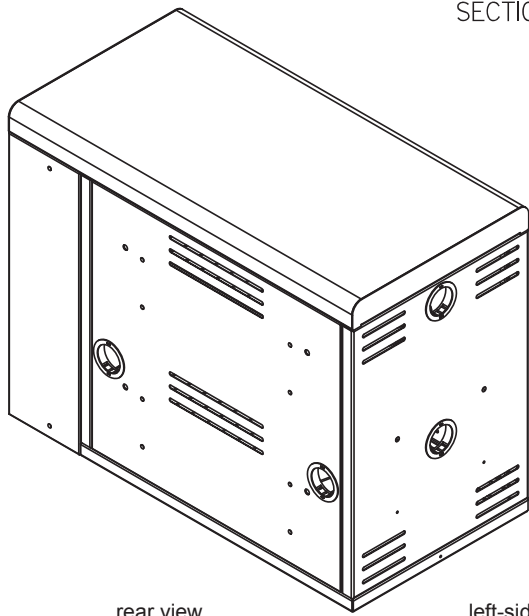

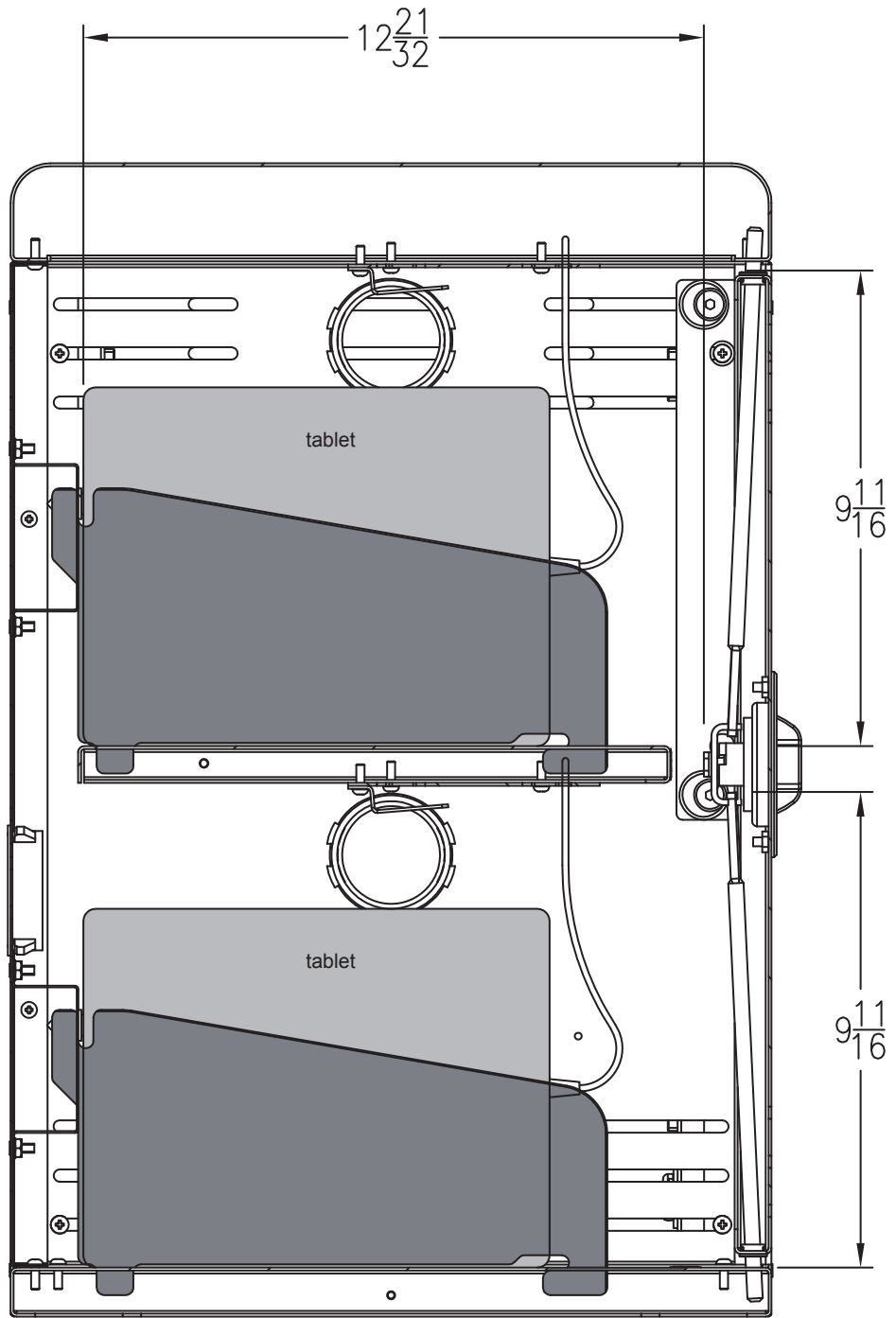

SECTION B-B

# Warranty

## WE WILL MAKE IT RIGHT FOR YOU!

Spectrum is committed to provide complete customer satisfaction. Each of our products are manufactured from the best materials available and each product is stringently monitored throughout the production process through our P.A.C.E. program (Product Assurance to meet Customer Expectations). Our Customer Service Help Line 1-800-235-1262 is ready to provide immediate attention to any questions, comments or concerns. We are available to answer your calls Monday through Friday from 7 am to 5 pm CST, excluding observed holidays. In addition your product comments or concerns are welcome via e-mail at: [spectrum@spectrumfurniture.com](mailto:spectrum@spectrumfurniture.com).

## Warranty Statement

We guarantee all Spectrum products to be free of all defects in materials and workmanship, for the original owner, for a period of ten years. Any item deemed defective by Spectrum or the original manufacturer, under normal use conditions, will be repaired or replaced at Spectrum's discretion. This warranty applies to all products manufactured and distributed by Spectrum except the products listed below.

Items that have a varying warranty include, but are not limited to, the following:

- Adjustable Crank/Electric Desk Legs (1 yr)
- Flat Panel Desk Gas Cylinders (1 yr)
- Upholstered Soft-Goods (5 yrs)
- Adjustable Height & Stacking Chair Parts – including frames, gas cylinders, wood and plastic parts, and control handles (7 yrs)
- Adjustable Height & Stacking Chair Casters (2 yrs)
- Chair Upholstery & Textiles (2 yrs of normal use of Soft Goods, Adjustable Height, Stacking, Wood and Metal Chairs)
- Chair Upholstery - Graded-In Fabrics and C.O.M (no warranty)
- Height Adjustable Columns and Lifts (1 yr)
- General Use Casters (1 yr)
- Electrical – Electri-Pak, Power Communication Modules, and special order ECA electrical items (1 yr)
- Electrical - Power Strips & Electrical Timers (1 yr)
- Electrical Surge Suppressors (lifetime)
- Electrical - Retractable Power Cords (1 yr)
- Keyboard/Mouse Trays (1 yr)
- Flat Panel Monitor Arm – General Parts (5 yrs)
- Flat Panel Monitor Arm – Gas Cylinders (2 yrs)
- CRT Monitor Arm (1 yr)

Warranty is void if product is not used for its intended purpose or subjected to an unusual application, multiple-shift use, alteration, accident, abuse or abnormal wear and tear. Representations of colors on-line and in printed materials are meant to be a close reference to the actual colors but not an exact match. Slight variations in color and texture of wood stains, powder coating, laminates, fabrics and other materials are normal in different manufacturing lots; as such these variations are not considered defects.

**DESIGNED FOR INDOOR USE ONLY** – Unless specifically stated in the product specifications, Spectrum's products have been designed and constructed for indoor use only. Moving or using outdoors, or on excessively rough surfaces, may cause damage to the products and will void the warranty. If an outdoor application is desired please contact us to discuss potential custom design solutions.

**The warranty, as stated above, supersedes any previous warranties and is effective as of 9/1/2010**

# Touchboards

205 Westwood Ave, Long Branch, NJ 07740  
Phone: 866-94 BOARDS (26273) / (732)-222-1511  
Fax: (732)-222-7088 | E-mail: [sales@touchboards.com](mailto:sales@touchboards.com)

 **SCS**certified™

**INDOOR AIR QUALITY**  
Indoor Advantage | Furniture

**ISO 9001:2008**  
Certified Company