

Technical Specifications

55471

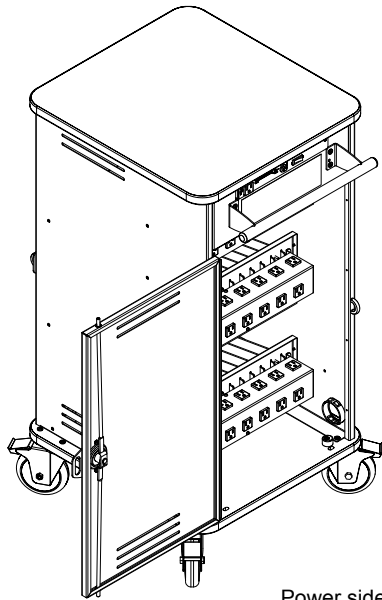

Power side

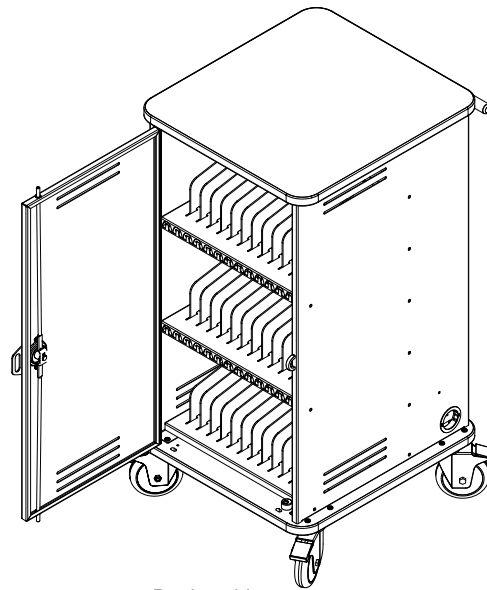

Device side

Use the InTouch42 Cart to store, transport, and charge up to 42 of the largest size tablets. Padded shelves and flexible dividers protect the tablets. Overhead wire management aids the wiring integration and allows the charging plugs to hang in front of each tablet. The cart's compact footprint and handle provide easy mobility. An external switch controls power to the cart and two external auxiliary outlets. A smart current-sensing timer provides adaptive switching, preventing electrical overload in underpowered classrooms, and will handle the next generation of tablets with high wattage charge adapters. The InTouch42 Cart is made with heavy-gauge steel for security and powder-coated for a durable, long-lasting finish. A dual-bolt lock and hasp on each door increase security of the tablets.

Includes:
Power switch

Note: This cart is designed to hold up to 42 tablets with power adapters up to 40 watts.

Features and Benefits

- Stores, charges, and transports up to 42 tablet computers including iPads® with large cases (up to 1.25" thick)
- 1.25"W x 13.75"D x 10.75"H storage bay
- Small cart footprint (22.125"W x 24"D) saves valuable space
- Durable ABS plastic dividers and shelf padding protect tablets from scratching (dividers are removable to provide storage space for thicker devices)
- Doors provide easy-access to device and power-side of cart (can be flipped to be hinged from the left or right)
- Double bolt locks, keyed, heavy gauge steel doors provide vault-like security for your investment
- Hasp locks provide an additional level of security and the ability to use your padlocks of choice (not included), or secure the unit to a wall
- Tablets and students are separated from all line voltage
- Superior, all-metal overhead cord management system keeps charge cords organized above each storage bay
- Power switch provides continuous power to all three 14-outlet power units (non current-sensing)
- Three horizontal, 14-outlet, (125V~/12A, 60Hz) universal power units work with both inline, and wall adapters
- External power switch provides easy-access for safe power connection / disconnection
- Auxiliary outlets (always on) for teacher laptop, wifi access point, or other accessory (1 external, 1 internal)
- Ventilated doors and side panels keep tablets and chargers cool, preventing overheating, and extending device life
- Replaceable, IEC quick-release, 15' nominal 14 AWG, 3-wire power cords provide easy power access
- Four inboard 5" locking balloon wheel plate casters with metal construction and non-marring rubber provide the easiest-rolling, and quietest transport in the industry (rated for 325 lb each)
- One all steel handle provides control and maneuverability and doubles as a power cord wrap
- Worksurface and base panel vinyl edging protects walls and furniture
- Cart ships fully-assembled with handle for quick, simple integration and deployment
- Durable powder coated steel chassis provides a long-lasting finish
- Scratch and impact-resistant high-pressure laminate top provides a durable, useful worksurface for instructors
- ETL recognized (certified to UL 60950-1) in the US and Canada for the cart and electrical system-**Pending**
- SCS Indoor Advantage Certified; meets or exceeds applicable ANSI-BIFMA test standards-**Pending**
- Warranted to be free of all defects in materials and workmanship for 10 years, electrical system 2 years
- Assembled in Chippewa Falls, WI, USA

Base
BW - 5" Balloon Wheels (4 swivel)

Color Options

Standard laminate / color combinations

White Fiesta / Silver Sparkle (WFS)



Standard color combination refers to the quickest deliverable product color combination. Custom laminates and color combinations are available-additional lead-times and up-charges may apply. Call 1-800-235-1262 for further information.

Construction

- The worksurface and base panel is constructed from 1.063" NAUF (No Added Urea Formaldehyde) composite board with .030" high-pressure laminate on one face, and a balancing phenolic backer on the opposing face
- Worksurface and base panel edges are covered with 3mm vinyl edge band
- 16-gauge side panels, shelves, and doors
- All metal components are finished with a scratch-resistant powder coat epoxy
- This cart is factory-assembled, packaged, and shipped on its own skid

Specifications

Capacity	42 tablets	
Storage bays (nominal)	1.25"W x 13.75"D x 10.75"H	
Electrical	<ul style="list-style-type: none"> • (3) 14-outlet power units (outlets rotated 90°) • 125V~/12A, 60Hz • 15-amp breaker • IEC quick-release (replaceable) 15' nominal, 14 AWG, 3-wire power cord 	<ul style="list-style-type: none"> • Locking power-side door isolates and separates electrical line voltage from students • UL-Listed components
Power Switch (non current-sensing)	<ul style="list-style-type: none"> • Low-profile, 16-gauge steel enclosure • 125V~/12A, 60Hz • Externally-accessible 20A power switch • Four continuous power unit-dedicated outlets (labeled A, B, C, D) (up to 10A power output) • Two auxiliary outlets (1 external, 1 internal) 1A each (controlled by main on/off switch) 	<ul style="list-style-type: none"> • IEC quick-release (replaceable) 15' nominal, 14 AWG, 3-wire power cord • ETL recognized (certified to 60950-1) - Pending • UL-Listed components
<p>Note: The customer should be aware of the amp draw of the tablets used with this cart-especially when maxing out the storage and charging capacity. Exceeding 15 amps per 14-outlet power unit will trip the circuit breaker. Please consult the owners manual of your specific device for power consumption information.</p>		
5" Balloon Wheels	Weight capacity 325 lb [148 kg] each	
Unit weight (nominal)	176 lb [79.9 kg]	
Shipping weight (nominal)	208 lb [94.4 kg]	

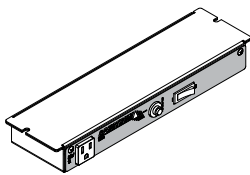

Specifications subject to change without notice

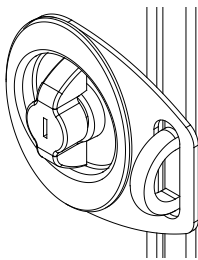

Double-bolt lock with padlock hasp (on both doors) (padlocks not included)

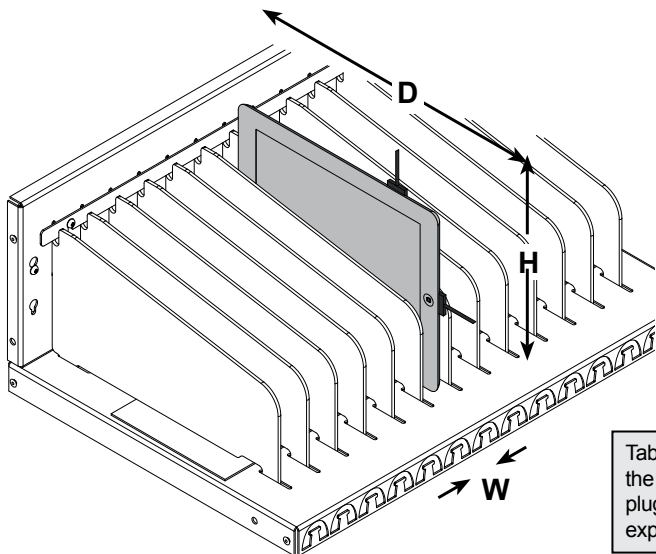

Tablets must be placed in the bays with the charge plug on one of the two exposed edges shown.

5" Balloon Wheel (BW)

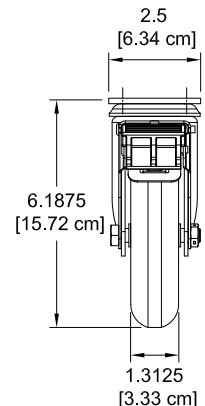
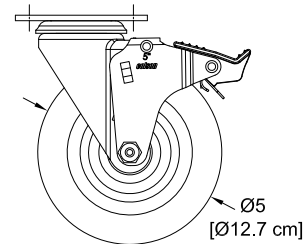
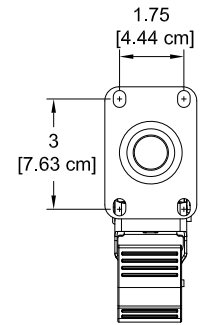
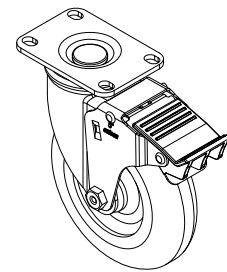

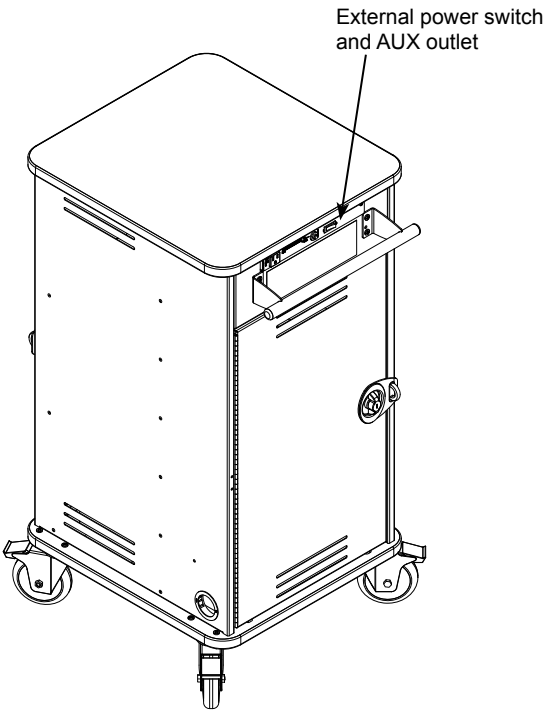

InTouch42
Tablet Cart

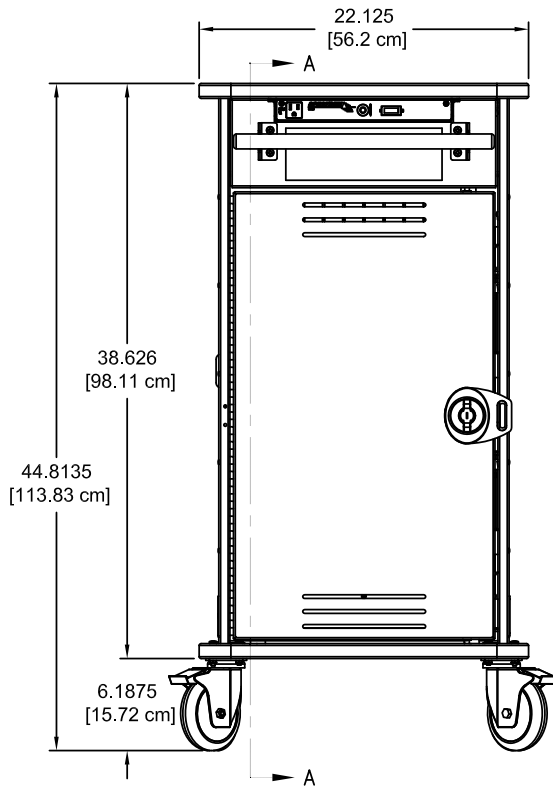
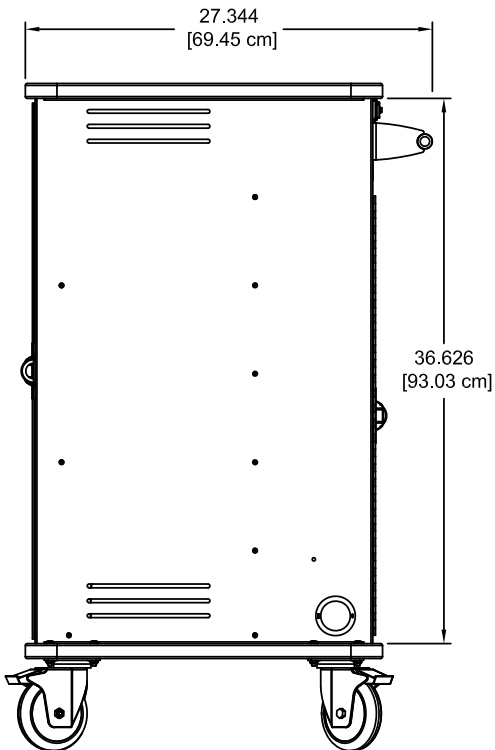
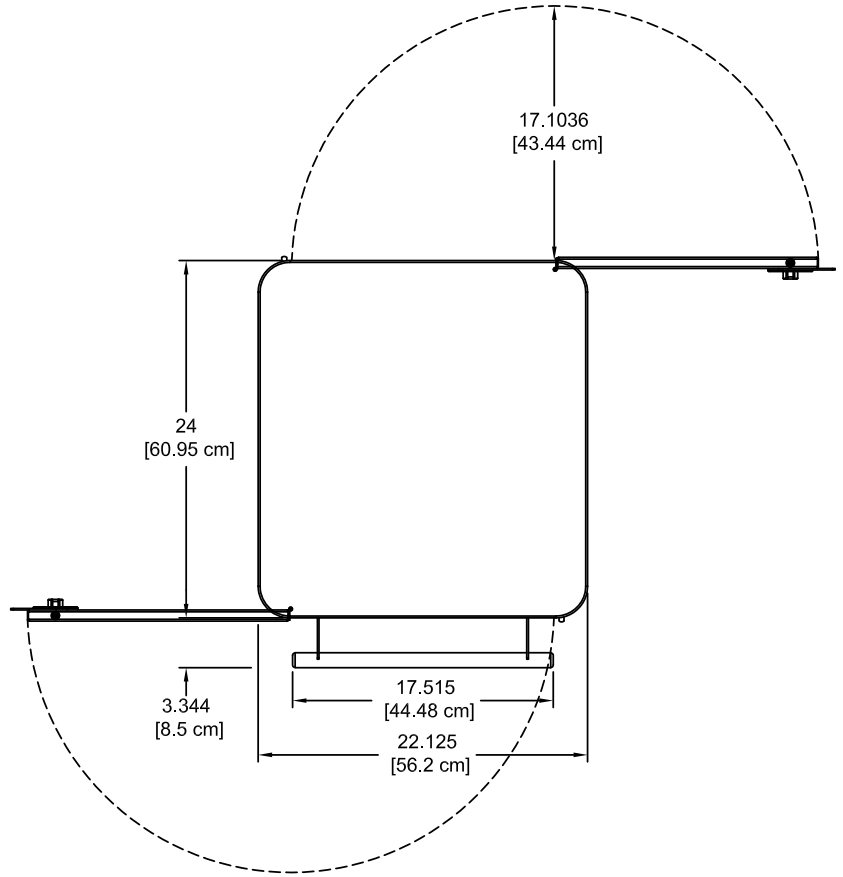

InTouch42
 Section view A-A
 (shown with common tablet models)

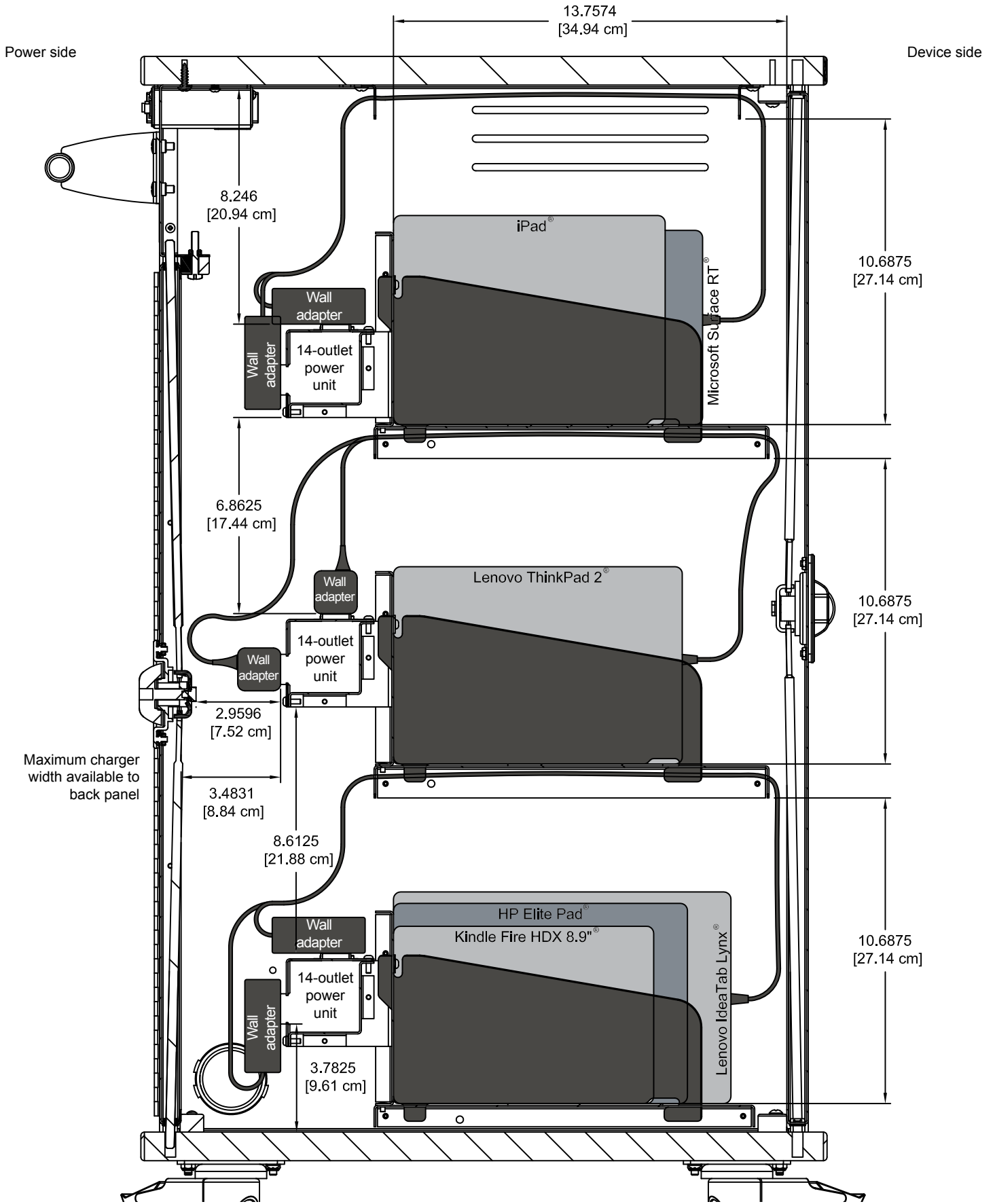

InTouch42
Device side view wiring diagram
(shown without rear door)

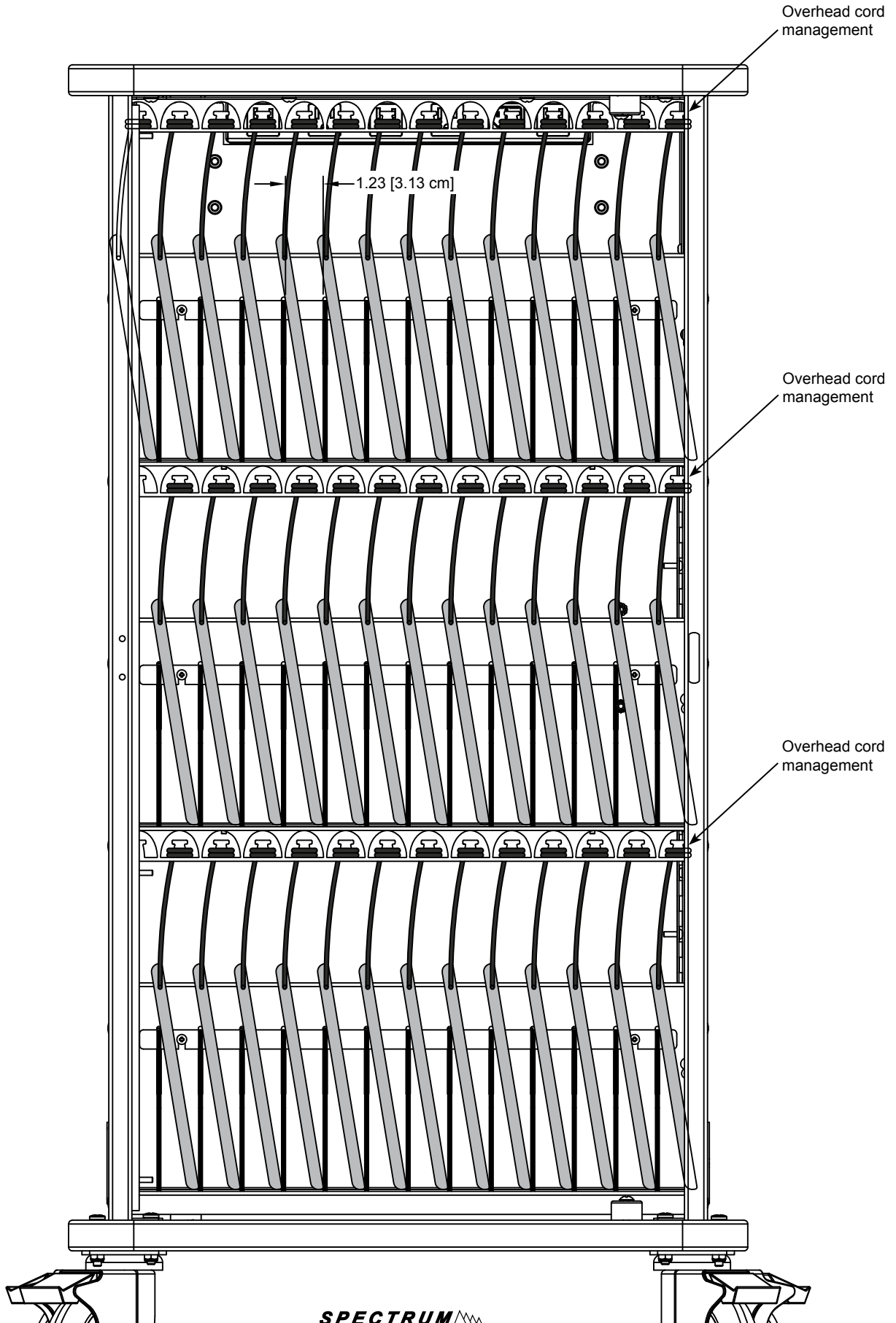

InTouch42 Power side wiring diagram (shown without door)

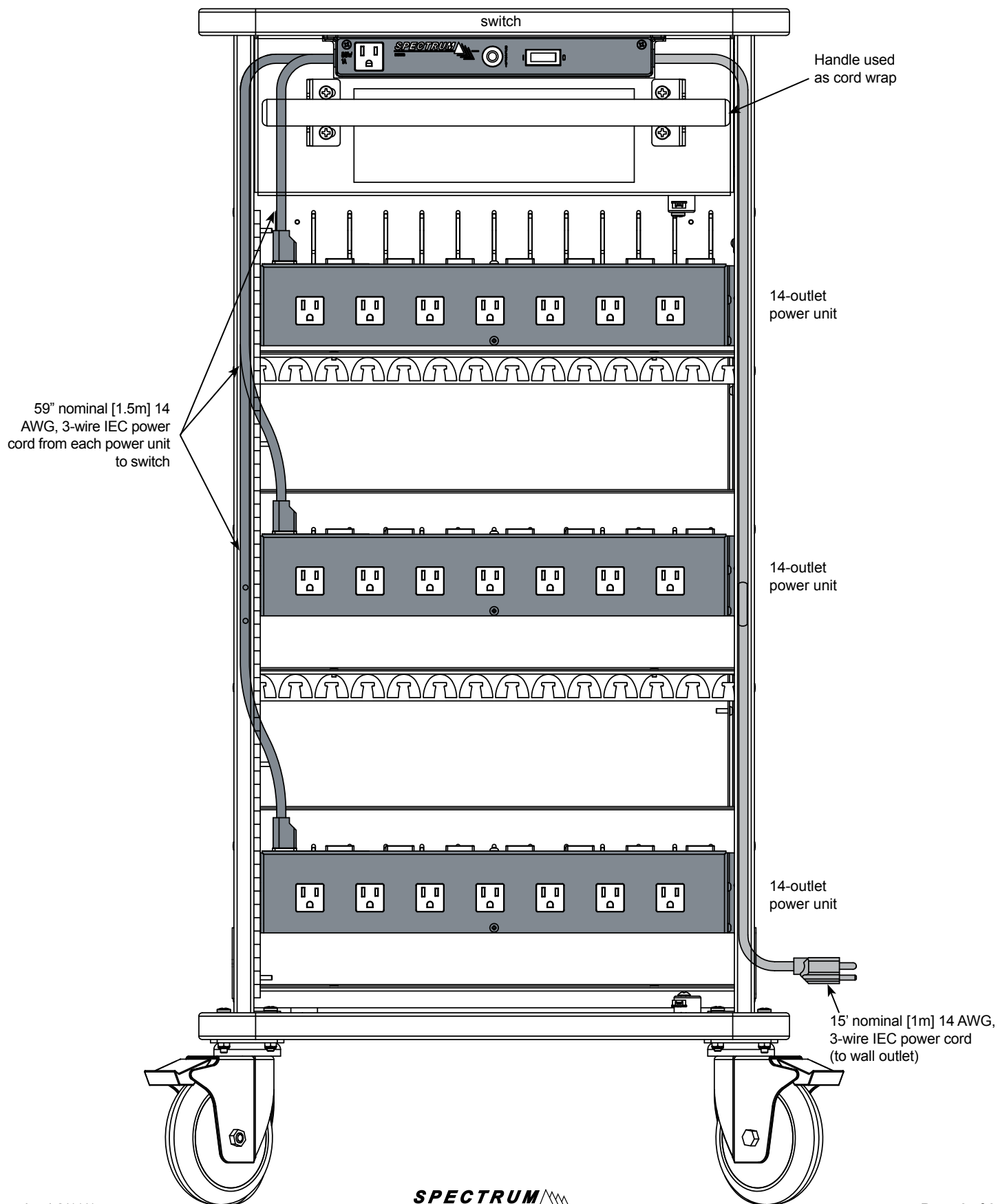

Power Switch
(Non current-sensing)

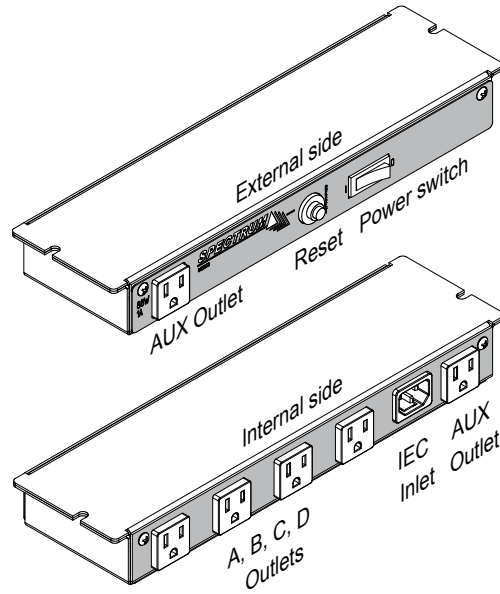

Nominal outlet spacing on
each 14-outlet power unit

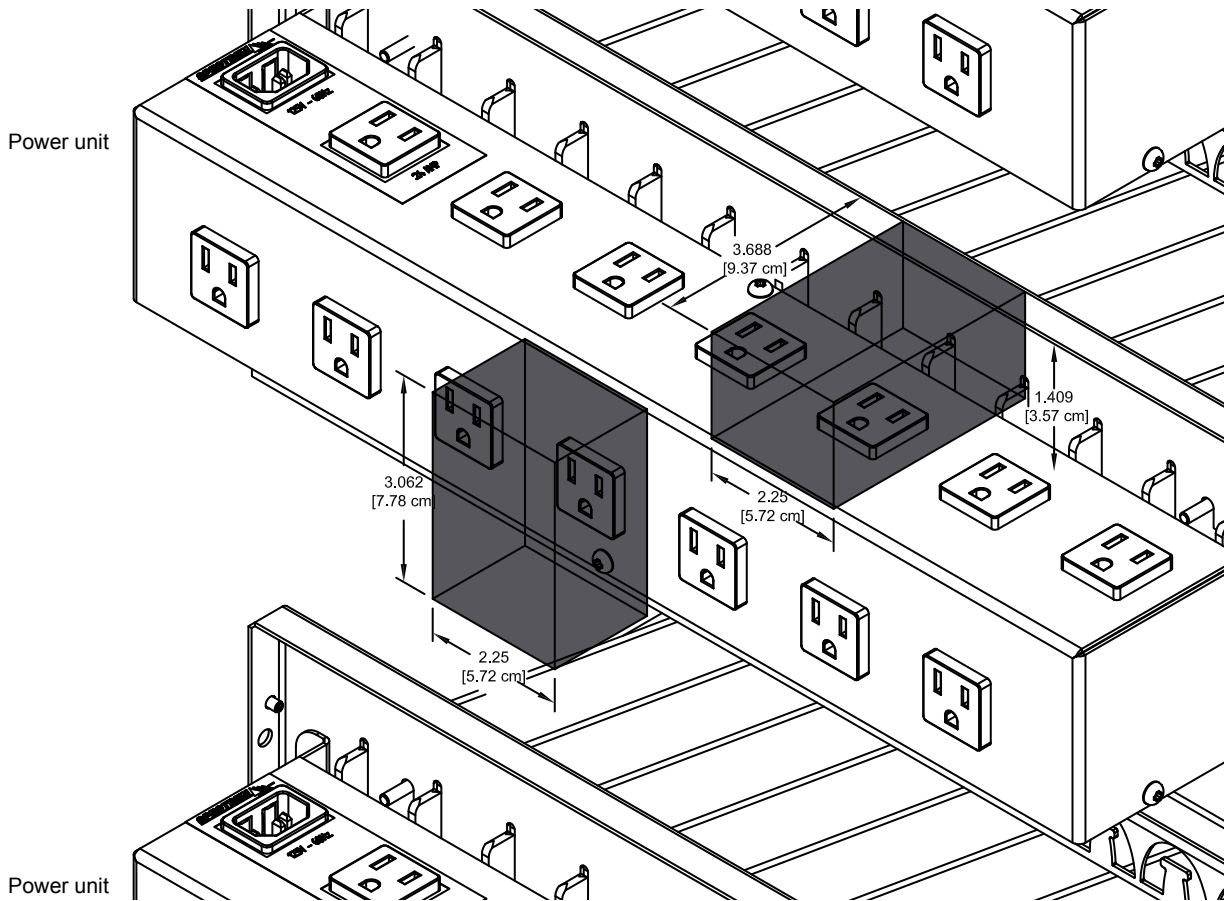

(See p.4 for spacing above and below outlets)

Options



Hook-and-loop strap kit

(16) .75" [1.91 cm] x 12" [30.48 cm],
and (32) .75" [1.91 cm] x 5" [12.7 cm]
95004

Warranty

WE WILL MAKE IT RIGHT FOR YOU!

Spectrum is committed to provide complete customer satisfaction. Each of our products is manufactured from the best materials available and each product is stringently monitored throughout the production process through our P.A.C.E. program (Product Assurance to meet Customer Expectations).

We expressly warrant that Spectrum products will be of good quality and workmanship and free from defect for the period set out in the warranty table below from the date of delivery. This warranty shall not apply to defects or damage resulting from misuse, abuse, neglect, improper care, modification or repair not authorized by Spectrum, or any other cause outside the control of Spectrum. Spectrum will, at its sole option, either repair or replace the defective product.

This warranty is exclusive; no other warranty, written or oral, is expressed or implied. This warranty is given by Spectrum to Buyer and to no other person or legal entity. No Spectrum dealer, distributor, agent or employee is authorized to make any modification or addition to this warranty.

NOTWITHSTANDING ANYTHING TO THE CONTRARY, SPECTRUM WILL NOT UNDER ANY CIRCUMSTANCES BE LIABLE FOR INDIRECT OR LIQUIDATED DAMAGES, INCLUDING CONSEQUENTIAL, INCIDENTAL AND SPECIAL DAMAGES. IN NO EVENT SHALL SPECTRUM'S LIABILITY, WHETHER UNDER CONTRACT OR WARRANTY, IN TORT OR OTHERWISE, EXCEED THE PURCHASE PRICE RECEIVED BY SPECTRUM FOR THE PRODUCT AT ISSUE AND "RECALL ACTION" EXPENSES. SPECTRUM SHALL NOT BE SUBJECT TO ANY OTHER OBLIGATIONS OR LIABILITIES, WHETHER ARISING OUT OF BREACH OF CONTRACT, WARRANTY, TORT (INCLUDING NEGLIGENCE AND STRICT LIABILITY) OR OTHER THEORIES OF LAW, WITH RESPECT TO PRODUCTS SOLD OR SERVICES RENDERED BY SPECTRUM, OR ANY UNDERTAKINGS, ACTS OR OMISSIONS RELATING THERETO.

Our Customer Service Department is ready to provide immediate attention to any questions, comments or concerns. They are available to answer your calls Monday through Friday from 7 am to 5 pm CST. In addition your product comments or concerns are welcome via e-mail at: spectrum@spectrumfurniture.com.

Warranty Table

effective 1/1/2015

Item	Warranty Period
Adjustable Crank/Electric Desk Legs	• 1 Year
Flat Panel Desk Gas Cylinders	
Chairs <ul style="list-style-type: none"> • Adjustable Height Chair Parts – including frames, gas cylinders, wood and plastic parts, control handles, casters • Adjustable Height Chair Upholstery • In-Stock Upholstery • Graded-In Fabrics and Customer Owned Material 	<ul style="list-style-type: none"> • 7 Years • 2 Years • 2 Years • No Warranty
Height Adjustable Columns and Lifts	• 1 Year
General Use Casters	
Electrical	• 2 Years
Keyboard/Mouse Trays	• 1 Year
Flat Panel Monitor Arms <ul style="list-style-type: none"> • Flat Panel Monitor Arm – General Parts • Flat Panel Monitor Arm – Gas Cylinders 	<ul style="list-style-type: none"> • 5 Years • 2 Years
Desks and Lecterns <ul style="list-style-type: none"> • Computer Desk Chassis • Cart Chassis • Lectern Chassis 	• 10 Years



205 Westwood Ave, Long Branch, NJ 07740
Phone: 866-94 BOARDS (26273) / (732)-222-1511
Fax: (732)-222-7088 | E-mail: sales@touchboards.com