

## Technical Specifications

55473

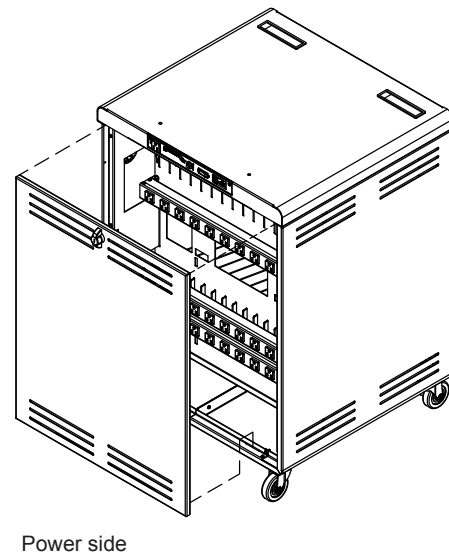

Use the Connect30 Cart to store, transport, and charge up to 30 tablets, Chromebooks or notebooks. A current-sensing PowerProdigy™ charging system is available if current requirements exceed 10 amps. Flexible dividers protect the devices. The overhead wire management aids the wiring integration and allows the charging plugs to hang in front of each device. The cart's compact footprint and top handles provide easy mobility. The Connect30 Cart is made with heavy-gauge steel for security and powder-coated for a durable, long-lasting finish. Locking door and panel increase notebook security.

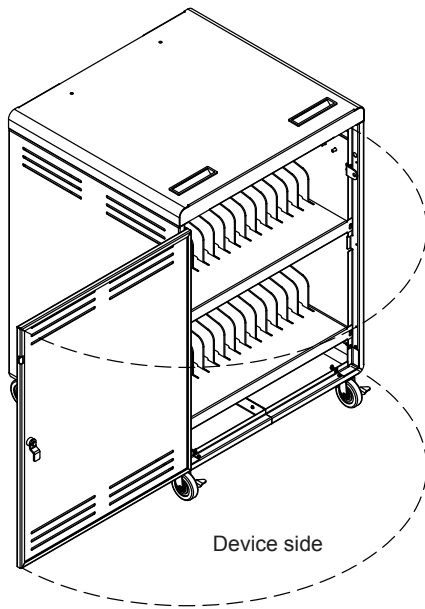

## Features and Benefits

- Stores, charges, and transports up to 30 devices (most tablets, Chromebooks, or notebooks up to 14")
- 1.349"W x 15.675"D x 10.913"H storage bay
- Small cart footprint (26"W x 24"D) saves valuable space
- Durable ABS plastic dividers protect devices from scratching (dividers are removable to provide storage space for thicker devices)
- Single keyed locks and heavy-gauge steel door and panel provide security
- Integrated padlock hasp in the hinged door provides an additional level of security and the ability to use your padlock of choice (not included), or secure the unit to a wall
- Devices and students are separated from AC line voltage
- Superior, all-metal overhead cord management system keeps charge cords organized above each storage bay

*Available with:*

- PowerProdigy™ charging system that senses current from three, 10-outlet power units and distributes power (up to 10A) to the least-charged devices first (where charging is needed most)  
**\*For most power adapters up to 90 watts**
- Available with Power Switch which provides continuous power to all three 10-outlet power units (non current-sensing)  
**\*For most power adapters up to 45 watts**
- Three horizontally adjustable, 10-outlet, (125V~/12A, 60Hz) universal power units work with both inline, and wall adapters
- External power switch provides easy-access for safe power connection / disconnection
- Two auxiliary outlets (always on) for teacher laptop, WiFi access point, or other accessory (1 external, 1 internal)
- Optional removable QuickBrick™ wiring trays with retaining straps for charge adapters allow wiring to be completed outside the cart at the comfort of a workstation or desk to provide quick and easy integration
- Ventilated door and side panels keep devices and chargers cool, preventing overheating, and extending device life
- Replaceable, IEC quick-release 8' nominal 14 AWG, 3-wire power cord and external cord wrap brackets provide easy power access

- Four inboard 5" balloon wheel plate casters (two locking, two nonlocking) with metal construction and non-marring rubber provide easy rolling, and quiet transport (rated for 300 lb each)
- Inset handles in top panel and optional steel handle provide control and maneuverability
- Cart ships fully-assembled with handle for quick, simple integration and deployment
- Durable powder coated steel chassis provides a long-lasting finish
- Scratch and impact-resistant high-pressure laminate top provides a durable, useful work surface for instructors
- ETL recognized (certified to UL 60950-1) in the US and Canada for the cart and electrical system
- Warranted to be free of all defects in materials and workmanship for 10 years, electrical system 2 years
- Designed and assembled in Chippewa Falls, WI, USA

Note: This cart is designed to hold up to 30 devices.

- 55473-CBQ** - w/ 5" wheels, PowerProdigy™ timer
- 55473-CBR** - w/ 5" wheels, Power switch
- 55473-CBT** - w/ 5" wheels, eLogix™ timer
- 55473-CB1** - w/ 5" wheels, PowerProdigy™ timer, & Handle
- 55473-CB2** - w/ 5" wheels, Power switch, & Handle
- 55473-CB3** - w/ 5" wheels, eLogix™ timer, & Handle

### Color Options



Metal:  
Warm Gray

# Construction

- 16-gauge side panels, shelves, door, and panel
- All metal components are finished with a scratch-resistant powder coat epoxy
- ABS plastic QuickBrick™ removable trays
- This cart is factory-assembled, packaged, and shipped on its own skid
- Handle requires customer-installation (handle versions only)

# Specifications

Capacity	30 Chromebooks, Tablets, or Notebooks	
Storage bays (nominal)	1.349"W [3.42 cm] x 15.675"D [39.81 cm] x 10.913"H [27.72 cm]	
Electrical	<ul style="list-style-type: none"> <li>• (3) 10-outlet power units (outlets rotated 90°)</li> <li>• 125V~/12A, 60Hz</li> <li>• 15-amp breaker</li> </ul>	<ul style="list-style-type: none"> <li>• Locking power-side panel isolates and separates electrical line voltage from students</li> <li>• ETL recognized (certified to 60950-1)</li> </ul>
Charging options  (See p.4 for specs)	<p><b>⚠ Note:</b> The customer should be aware of the amp draw of the devices used with this cart-especially when maxing out the storage and charging capacity. Exceeding 15 amps will trip the circuit breaker. Please consult the owners manual of your specific device for power consumption information.</p>	
Wheels	5" Balloon Wheels (total locking) - Weight capacity 300 lb [136.2 kg] each	
Certifications / Compliance	<ul style="list-style-type: none"> <li>• ETL recognized</li> <li>• SCS Indoor Advantage Certified</li> </ul>	<ul style="list-style-type: none"> <li>• Meets or exceeds applicable ANSI-BIFMA test standards</li> </ul>
Unit weight (nominal)	150 lb [68.1 kg]	
Shipping weight (nominal)	170 lb [77.2 kg]	

*Specifications subject to change without notice*

Note: Do not place items weighing more than 50 lb [22.7 kg] on the top surface. Please remove or secure items before moving cart.

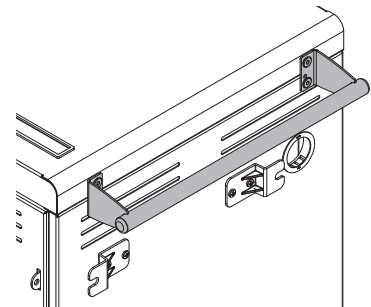
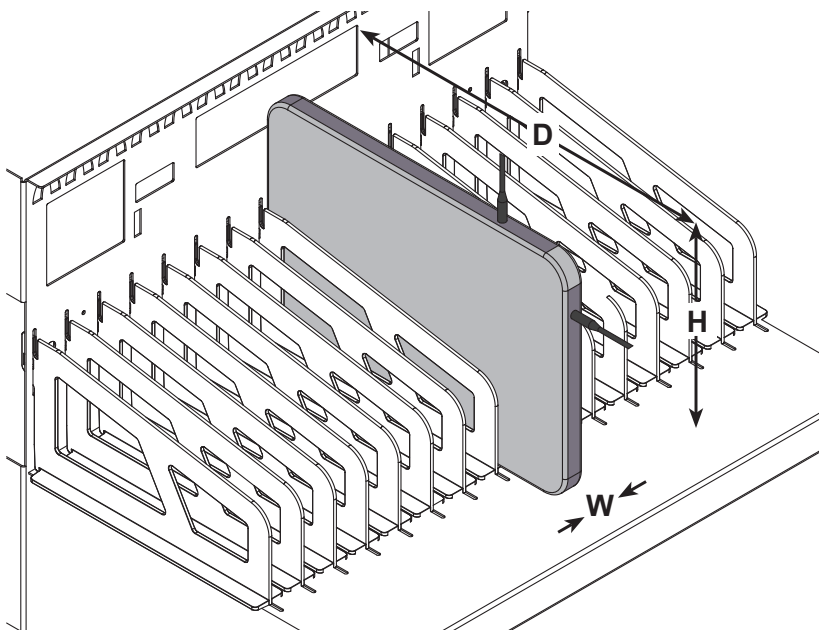

Optional Steel Handle (black)  
(customer-installed)

Notebooks / laptops must be placed in the bays with the charge plug on one of the two exposed edges shown.

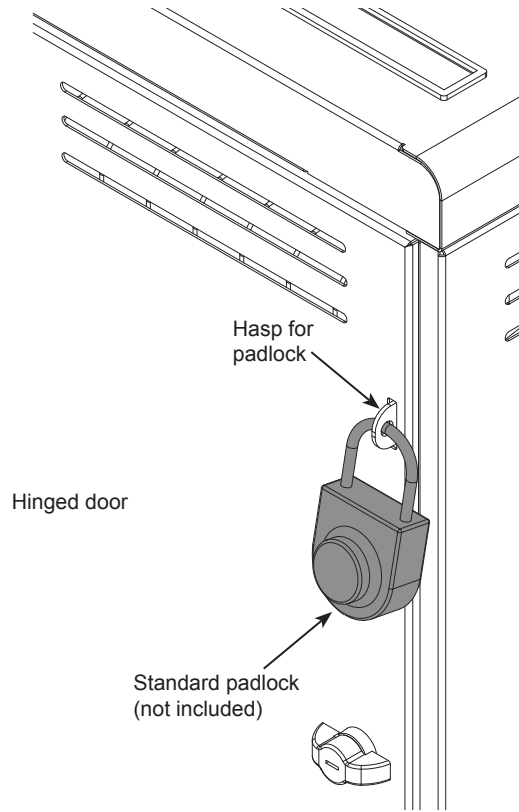

5" Balloon Wheel

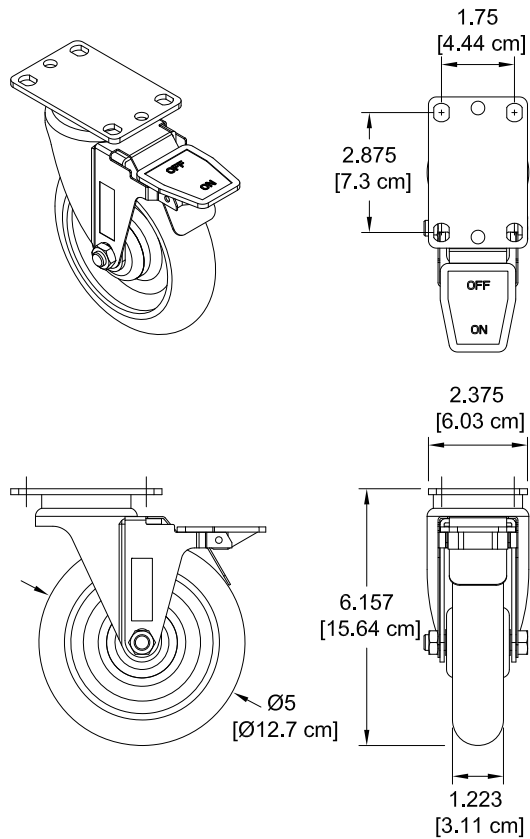

Connect30™ Electrical comparison		
PowerProdigy™ Timer	Power Switch	
✓	✓	External auxiliary outlet
✓	✓	Internal auxiliary outlet
✓	✓	External on/off switch
✓		Load-sensing technology
✓		4 bank
✓		*For most power adapters up to 90W
	✓	*For most power adapters up to 45W
✓		LED lights indicate charging status
✓	✓	ETL certified to 60950-1

*\*Total maximum wattage will be effected by actual charge adapter wattage and number of charge adapters per cart. See more wattage / adapter information below.*

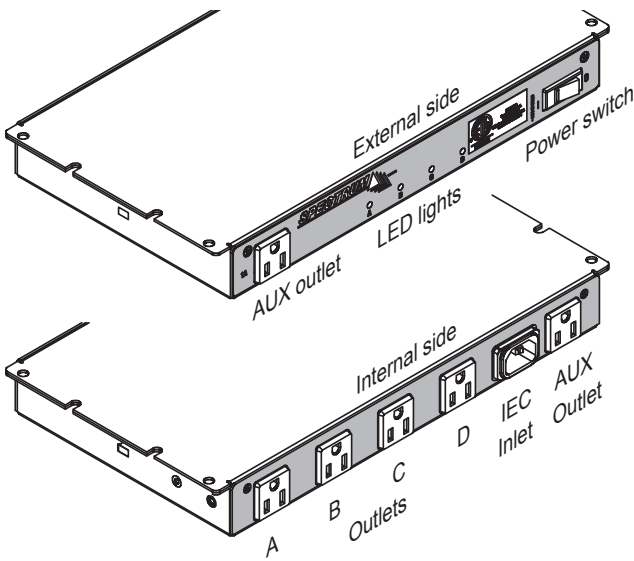

**PowerProdigy™ Timer**

**Use with higher amp-draw devices. On the Connect30, the PowerProdigy™ Timer can be used with most power adapters up to 90W.**

- Smart charging senses current and distributes power to the power units requiring it most
- Four green LED lights indicate charging activity status of each power unit
- Four timed power unit-dedicated outlets (labeled A, B, C, D) controlled by logic board
- Two auxiliary outlets (1 external, 1 internal)
- ETL recognized (certified to 60950-1)

Input:	125V~/12A, 60Hz
Breaker:	15A, 250 VAC
Cycling interval:	15 minutes
Cycling outlets:	4 timed (A, B, C, D) up to 10A
Auxiliary outlets:	1A each (controlled by main power switch)
Power Cord:	IEC quick-release (replaceable) 8' nominal, 14 AWG, 3-wire
Power switch:	15A (externally accessible)

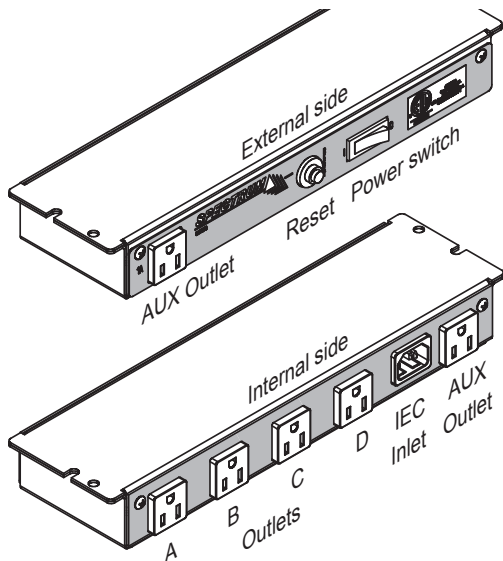

**Power Switch**

**The Power Switch provides continuous power to all power units. Use with lower amp-draw devices. On the Connect30, the Power Switch can be used with most power adapters up to 45W.**

- Four continuous power-unit dedicated outlets (labeled A, B, C, D)
- Two auxiliary outlets (1 external, 1 internal)
- ETL recognized (certified to 60950-1)

Input:	125V~/12A, 60Hz
Breaker:	15A, 250 VAC
Outlets:	4 timed (A, B, C, D) up to 10A
Auxiliary outlets:	1A each (controlled by main power switch)
Power Cord:	IEC quick-release (replaceable) 8' nominal, 14 AWG, 3-wire
Power switch:	15A (externally accessible)

Connect30 Cart

Shown with optional handle

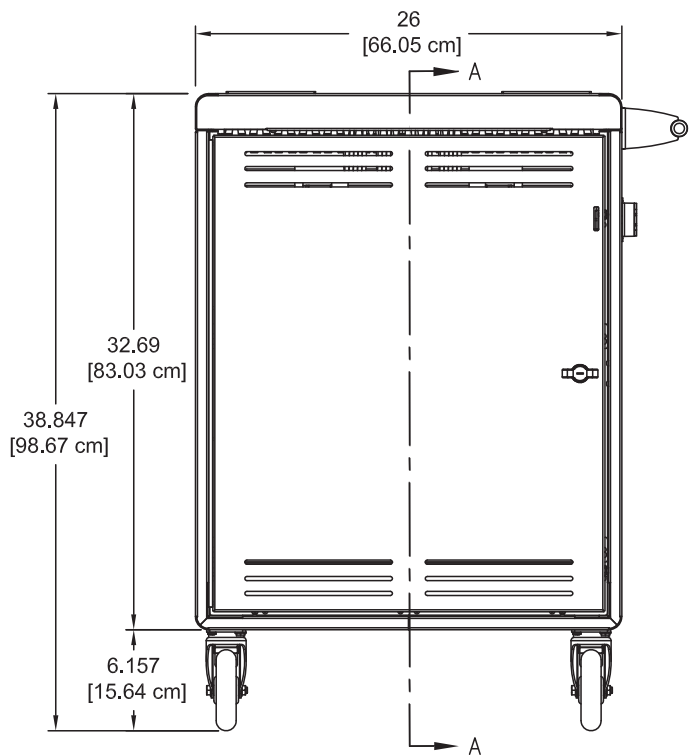
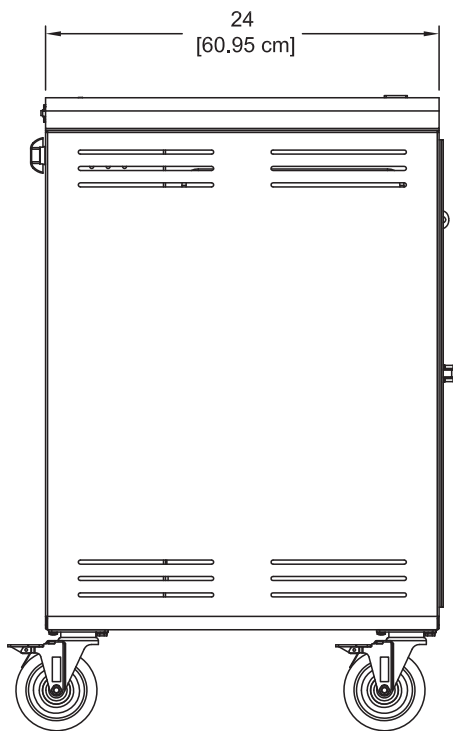
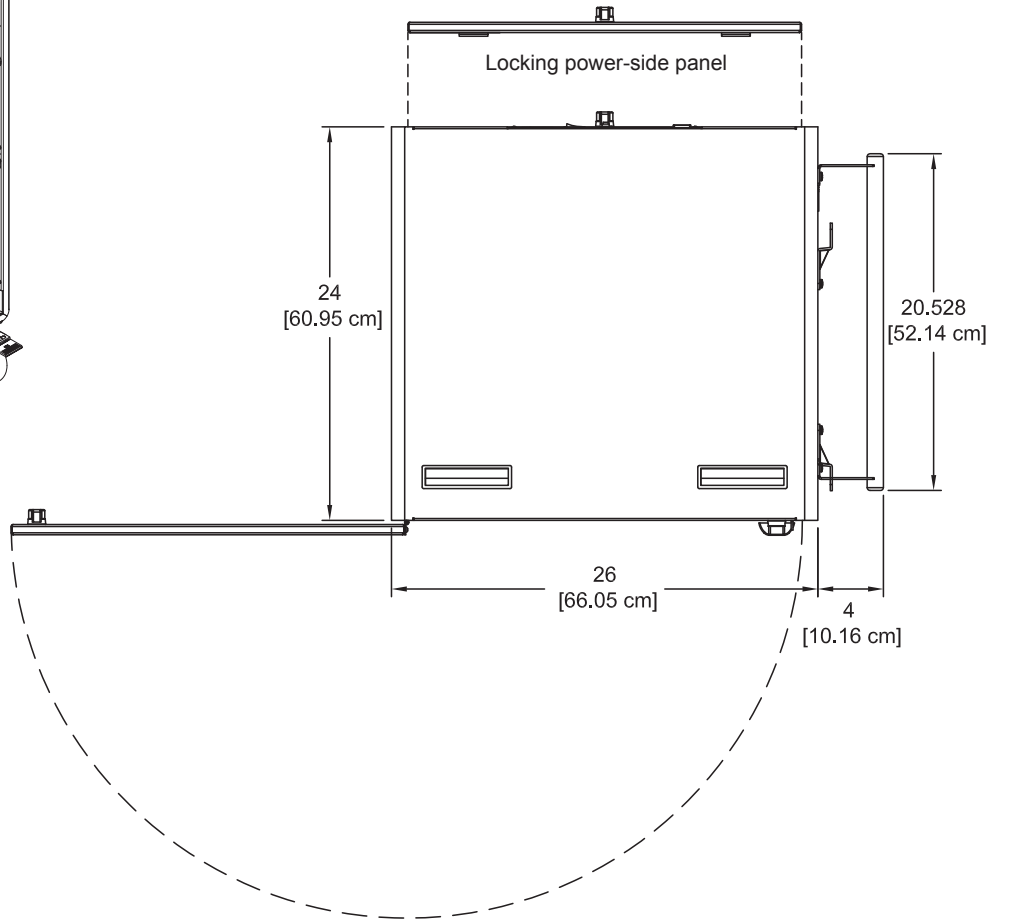
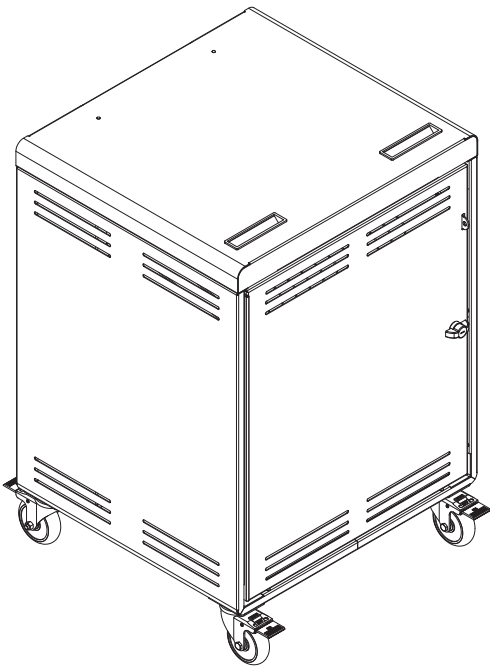

Connect30  
Section view A-A

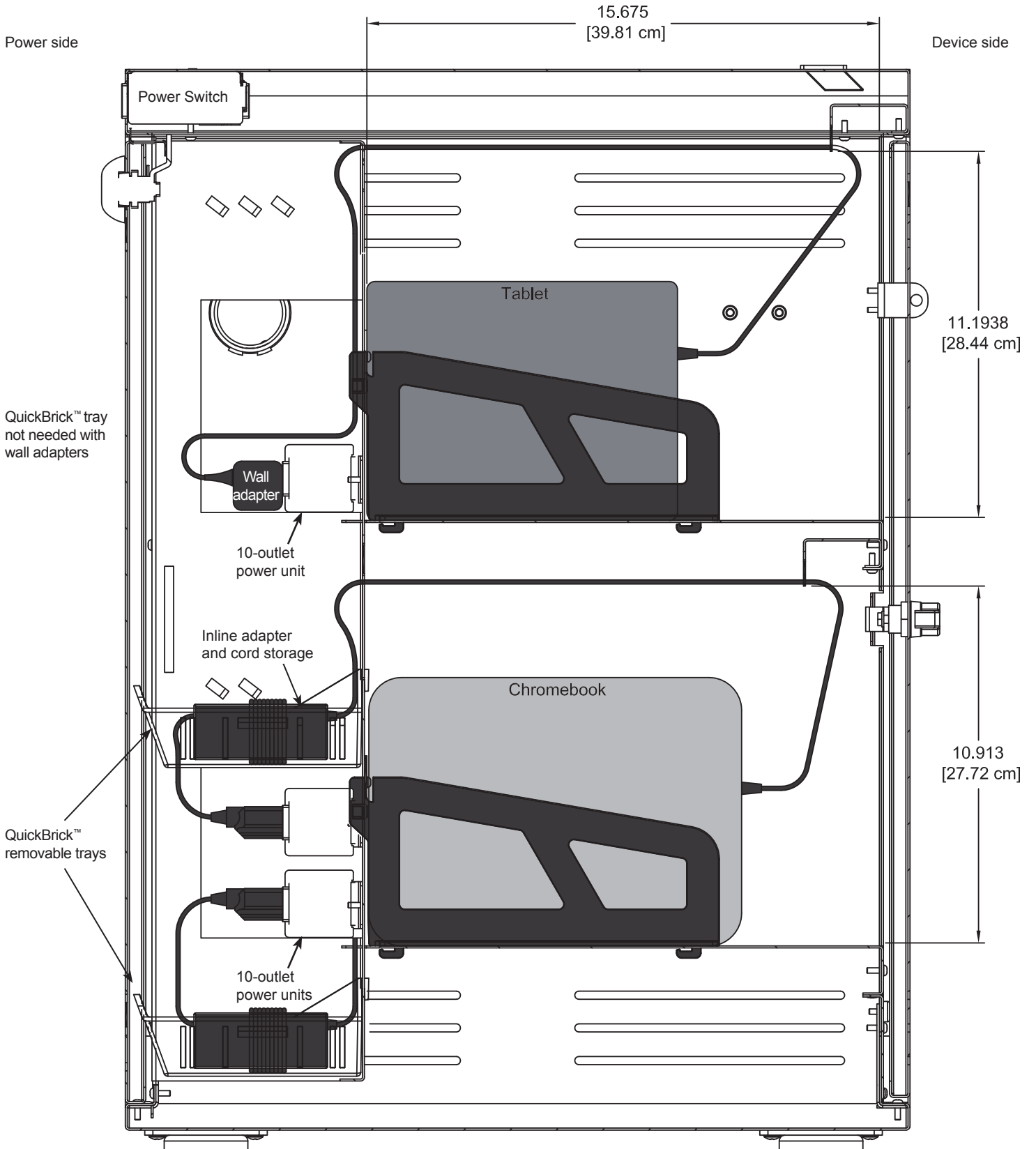

Connect30  
Device side view wiring diagram  
(shown without door)

1.349  
[3.42 cm]

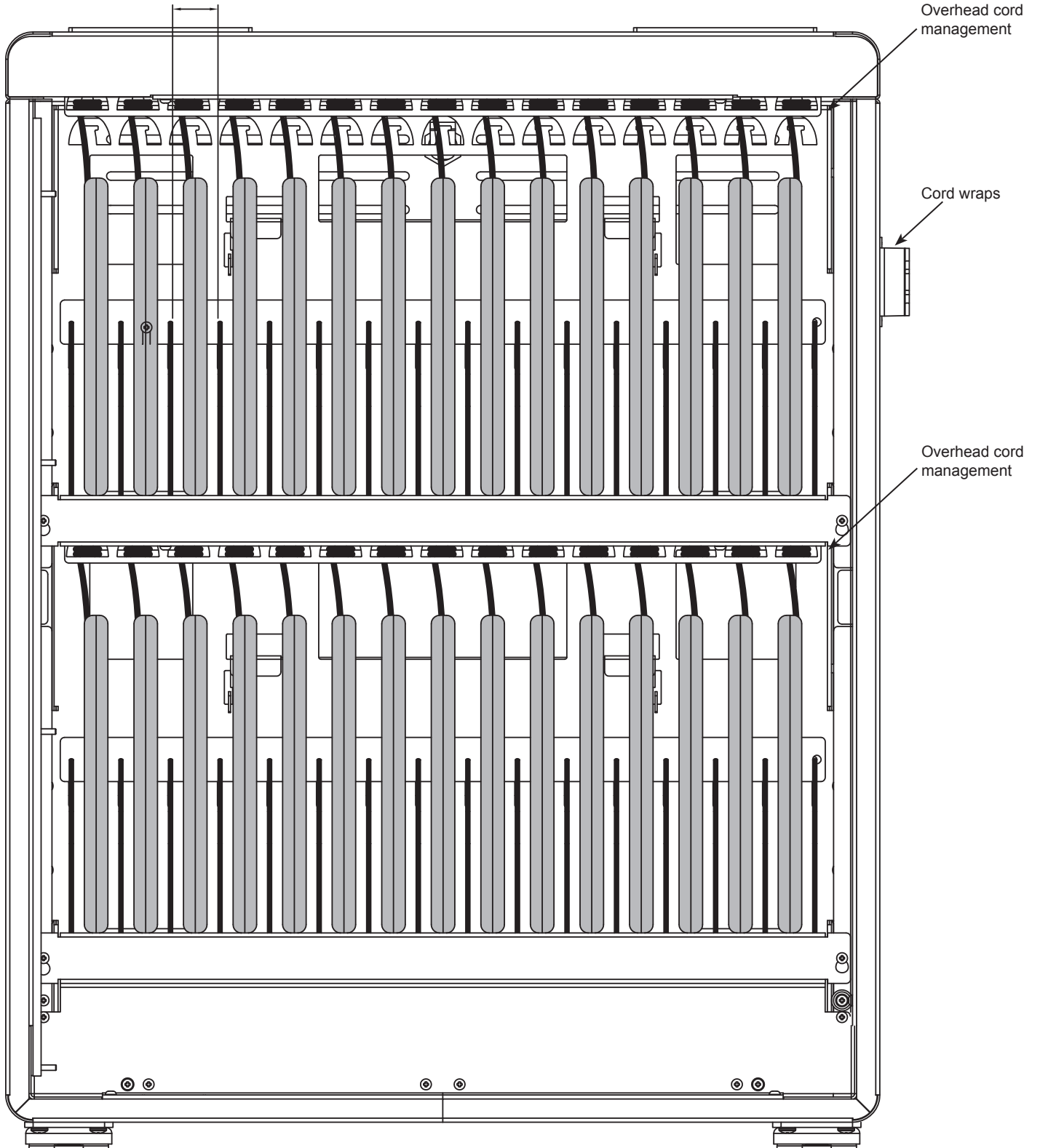

Overhead cord management

Cord wraps

Overhead cord management

Connect30  
Power side wiring diagram  
(shown without locking panel)

15' nominal [1m] 14 AWG,  
3-wire IEC power cord  
(to wall outlet)

Power cord to switch  
or timer

(Shown with PowerProdigy™ Timer)

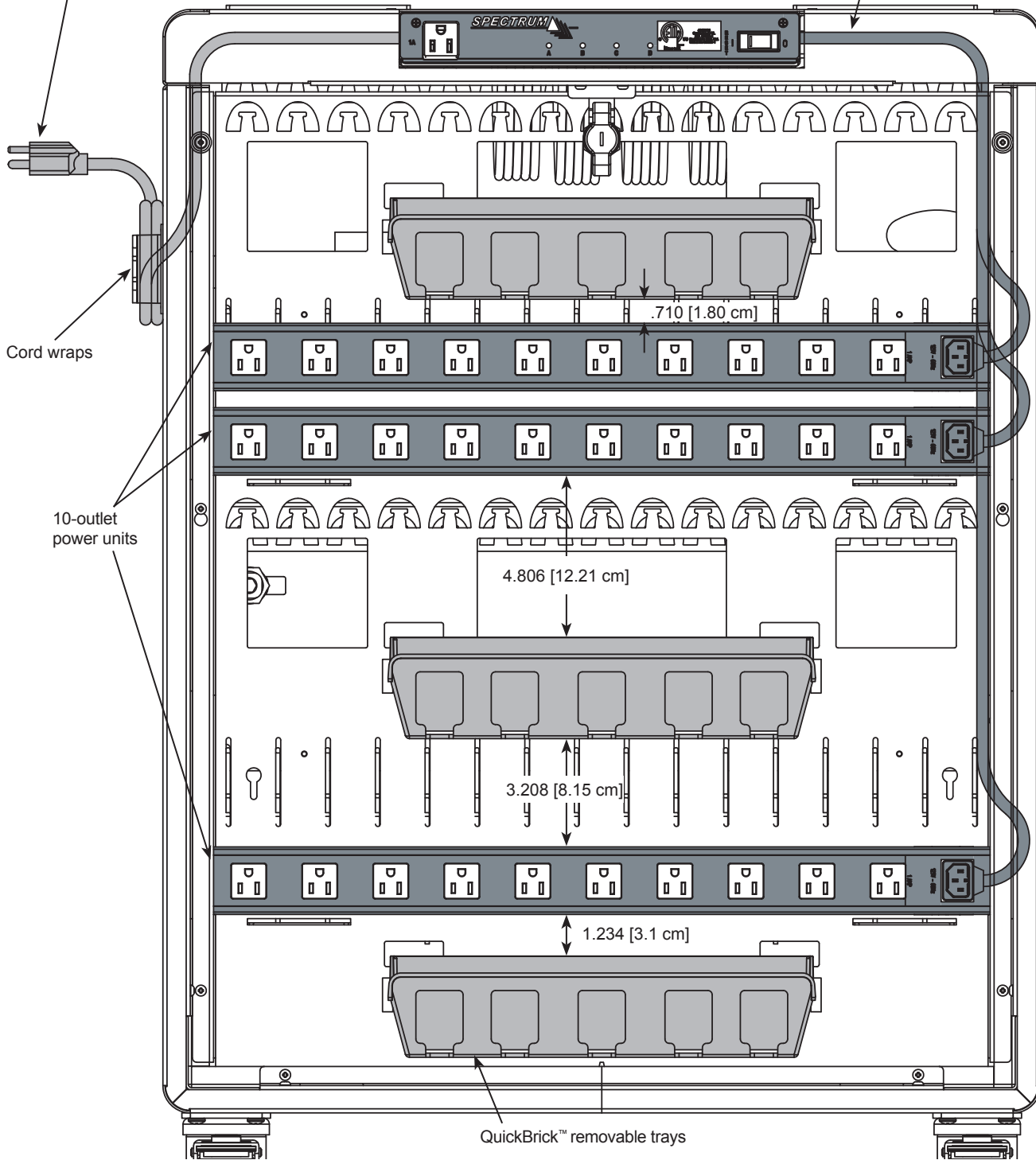



Note: Each 10-outlet power unit is designed with 1.68" of horizontal adjustability to provide outlet stagger if necessary. This helps accommodate a wide variety of wall adapter plug sizes and configurations.

Power unit adjustability and Nominal outlet spacing on each 10-outlet power unit

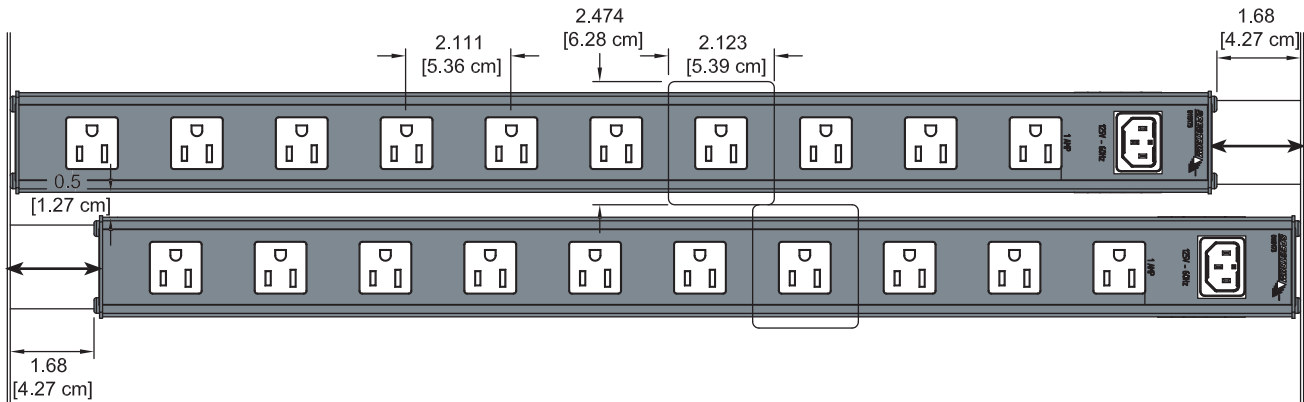

(See p.8 for spacing above and below outlets)

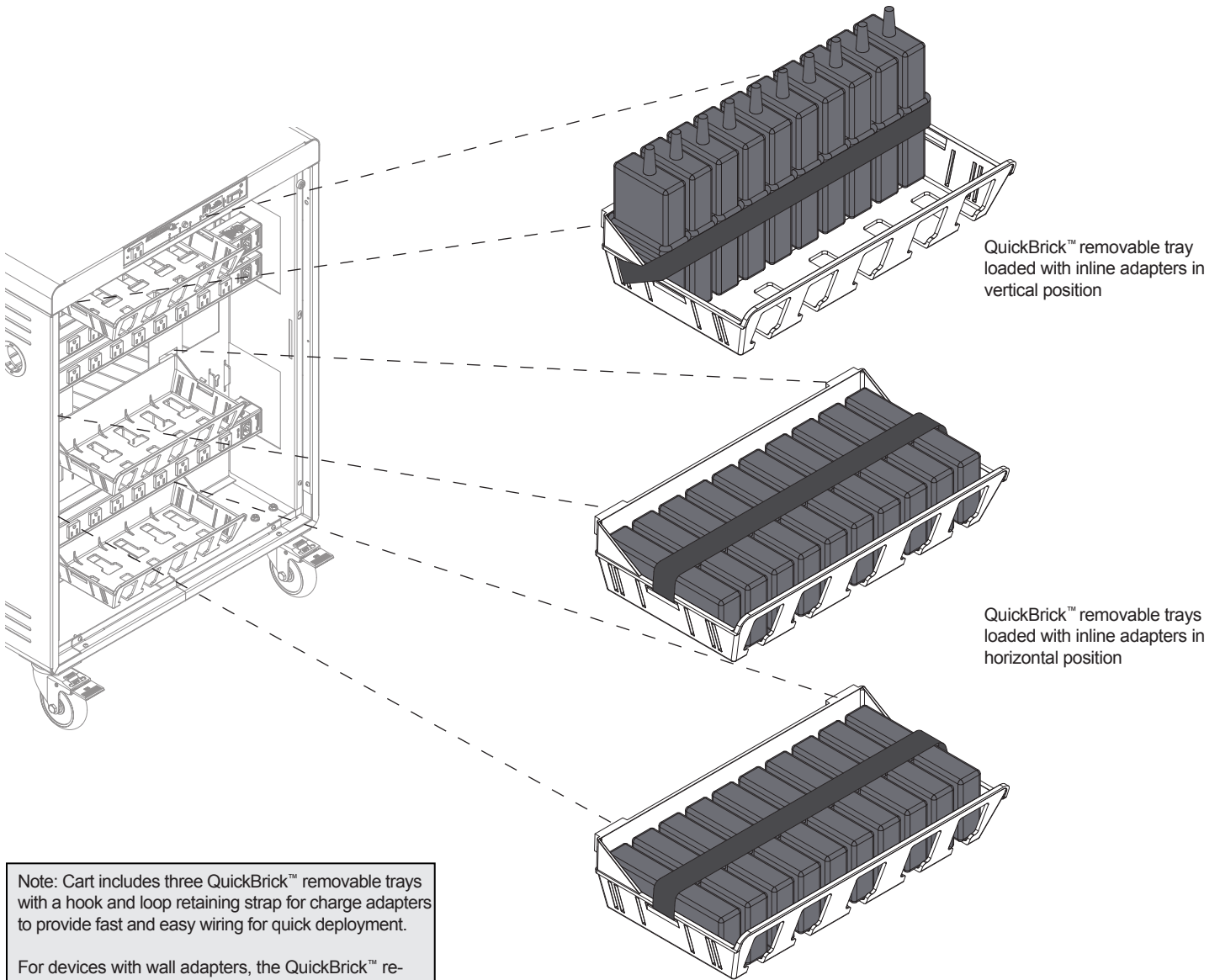

Note: Cart includes three QuickBrick™ removable trays with a hook and loop retaining strap for charge adapters to provide fast and easy wiring for quick deployment.

For devices with wall adapters, the QuickBrick™ removable trays can be used to store bundled cords.

## Accessories

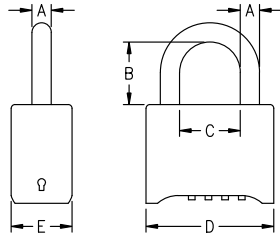

A	.3125" [7.9 mm]
B	1" [25.4 mm]
C	.983" [25 mm]
D	2.07" [52.5 mm]
E	.987" [25.1 mm]

### Re-programmable 4-digit Combination Lock - 95536

- Set your own 4-digit personalized combination (up to 10,000 options)
- 5/16" hardened steel shackle for cut-resistance
- Black powdercoated die-cast body for durability
- Change key included
- Unit weight: .55 lb [.25 kg]

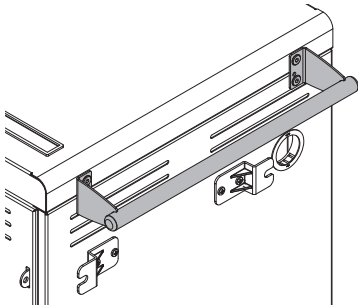

### Steel Handle - 55393

- Customer-installed accessory for units purchased without configured handle
- 20"W [50.8 cm]
- Shipping weight: 2.2 lb [1 kg]

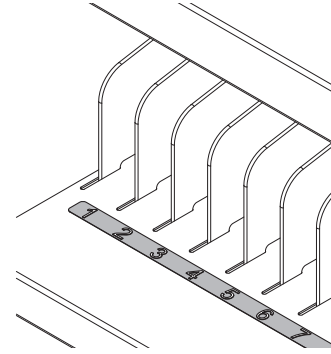

### Slot labels for Connect30 - 55476

- Black numbers on transparent adhesive backer
- 1-15 label, 16-30 label



### Hook-and-loop Strap Kit - 95004

(16) .75" [1.91 cm] x 12" [30.48 cm],  
and (32) .75" [1.91 cm] x 5" [12.7 cm]

# Warranty

## We will make it right for you!

Spectrum is committed to provide complete customer satisfaction. Each of our products is manufactured from the best materials available and each product is stringently monitored throughout the production process through our Quality Management System.

We expressly warrant that Spectrum products will be of good quality and workmanship and free from defect for the period set out in the warranty table below from the date of delivery. This warranty shall not apply to defects or damage resulting from normal wear and tear, misuse, or unintended use, failure to follow instructions related to the product's installation or intended use, abuse, neglect, improper care, modification or repair not authorized by Spectrum, or any other cause outside the control of Spectrum. Spectrum will, at its sole option, either repair or replace the defective product.

This warranty is exclusive; no other warranty, written or oral, is expressed or implied. This warranty is given by Spectrum to Buyer or Buyer third party end user and to no other person or legal entity. No Spectrum dealer, distributor, partner, reseller, agent or employee is authorized to make any modification or addition to this warranty.

**NOTWITHSTANDING ANYTHING TO THE CONTRARY, SPECTRUM WILL NOT UNDER ANY CIRCUMSTANCES BE LIABLE FOR INDIRECT OR LIQUIDATED DAMAGES, INCLUDING CONSEQUENTIAL, INCIDENTAL AND SPECIAL DAMAGES. IN NO EVENT SHALL SPECTRUM'S LIABILITY, WHETHER UNDER CONTRACT OR WARRANTY, IN TORT OR OTHERWISE, EXCEED THE PURCHASE PRICE RECEIVED BY SPECTRUM FOR THE PRODUCT AT ISSUE AND "RECALL ACTION" EXPENSES. SPECTRUM SHALL NOT BE SUBJECT TO ANY OTHER OBLIGATIONS OR LIABILITIES, WHETHER ARISING OUT OF BREACH OF CONTRACT, WARRANTY, TORT (INCLUDING NEGLIGENCE AND STRICT LIABILITY) OR OTHER THEORIES OF LAW, WITH RESPECT TO PRODUCTS SOLD OR SERVICES RENDERED BY SPECTRUM, OR ANY UNDERTAKINGS, ACTS OR OMISSIONS RELATING THERETO.**

Our Customer Service Department is ready to provide immediate attention to any questions, comments or concerns. They are available to answer your calls Monday through Friday from 7 am to 5 pm CST. In addition your product comments or concerns are welcome via e-mail at: [spectrum@spectrumfurniture.com](mailto:spectrum@spectrumfurniture.com).

Warranty Table

Item	Warranty Period
Desk, table, cart and lectern chassis	10 Years
Electrical	2 Years
Flat panel monitor arms / gas spring / general parts	2 Years
Adjustable crank / electric legs and accessories	2 Years
Flat panel desk gas spring cylinders	2 Years
Height adjustable columns, lifts & accessories	2 Years
Casters & wheels	2 Years
Keyboard, mouse, trays	2 Years
Locks & keys	2 Years
Tubs, totes and other accessories	1 Year
Chairs Structural components, including gas cylinders, wood, metal and plastic parts (i.e., chair frames, bases and control handles)	7 Years
Consumable items (i.e., casters, glides, etc.)	5 Years
In-stock upholstery	5 Years
Customer supplied material	No Warranty

